

2024  
**BRAKE PADS AND SHOES**  
FOR MOTORCYCLES, SCOOTERS, DIRT BIKES AND ATV/UTV

**EDGE R90**

**sbs**<sup>®</sup>  
GO AHEAD

 **BETTER BRAKES**  
HI-TECH BRAKE SOLUTIONS  
MADE IN EUROPE



**ES** **IT**



[SBSBRAKES.COM](http://SBSBRAKES.COM)

SBS  
BETTER  
BRAKES  
SEE PAGE 4-5



# Get the brake feel you want!



GO AHEAD

Find the right brake pad compound for you and your bike with the new **Compound Selector** at [sbsbrakes.com](http://sbsbrakes.com)

Find the right compound for you and your bike

Click Start Now, answer 2-3 questions and get the answer right away

START NOW



@sbsbrakes | [sbsbrakes.com](http://sbsbrakes.com) | #GoAhead

HI-TECH BRAKE SOLUTIONS MADE IN EUROPE





GO AHEAD

HI-TECH BRAKE SOLUTIONS  
MADE IN EUROPE

# TRY THE NEW BETTER BRAKES FOR A BETTER BRAKE PERFORMANCE

We all need to do what we can to reduce our environmental impact, motorcyclists are no exception. Just not at the expense of performance!

SBS has refined its compounds to do exactly that, while also improved the brake performance throughout the brake pad lifetime. Get the improved lever feel, improved recovery, high heat resistance and stronger initial bite you seek, with the new SBS Better Brakes HF, HS and MS.

Better brakes, for a better ride. Go Ahead.

More see page 4-5.

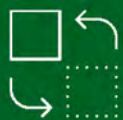

REFINED COMPOUND

Brake compounds are 100% Copper- and Nickel-free, and for ceramic compounds also Antimony-free.



IMPROVED BRAKE PERFORMANCE

A better and more stable brake performance and stopping power.



NUCAP NRS TECHNOLOGY

Always equipped with the powerful bonding technology that binds the friction material to the backing plate and improves heat resistance.



@sbsbrakes | sbsbrakes.com | #GoAhead



# HOW TO CHOOSE YOUR BRAKE PADS

## THE RIGHT CHOICE FOR YOUR MOTORCYCLE AND YOUR RIDING STYLE.

1. Choose your motorcycle type "Street Motorcycles", "American Motorcycles", "Scooter", "Road Racing", "Off Road", "ATV".
2. Find your "Type of use" in the matching diagram.
3. Pick the compound matching your needs and requirements.
4. Go to the "Motorcycle Model Applications" section to find your bike and matching SBS brake pad numbers.

### STREET MOTORCYCLES

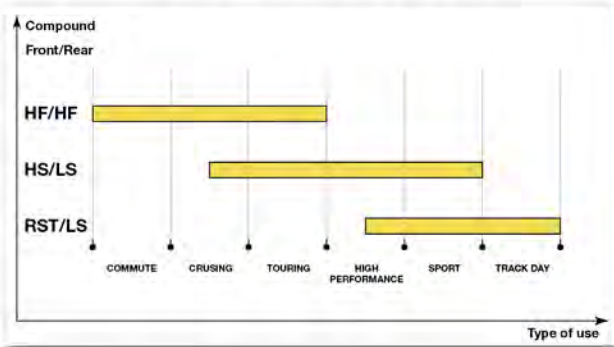

### AMERICAN MOTORCYCLES

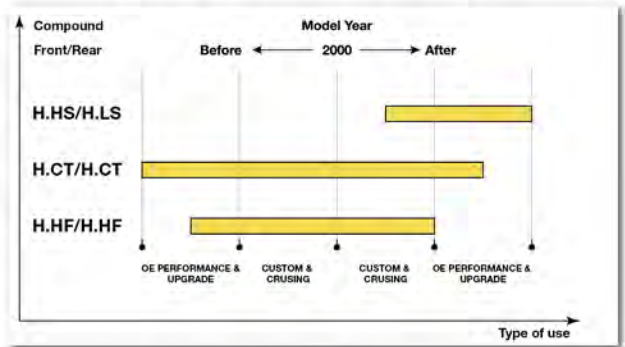

### SCOOTER

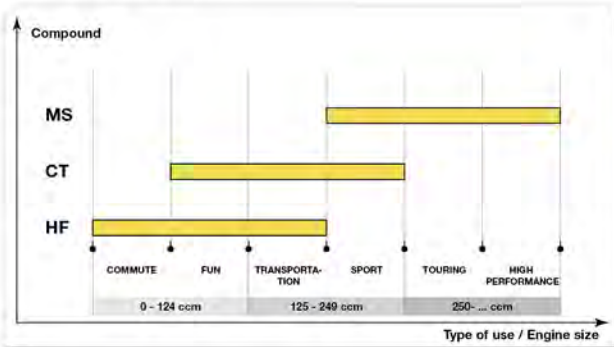

### ROAD RACING

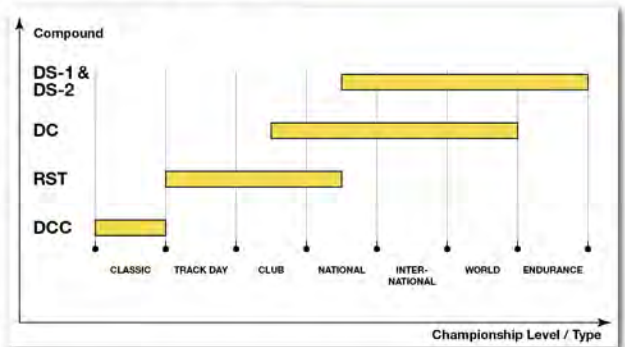

### OFF ROAD

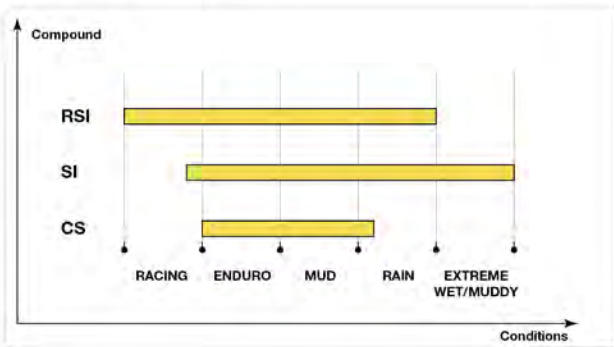

### ATV

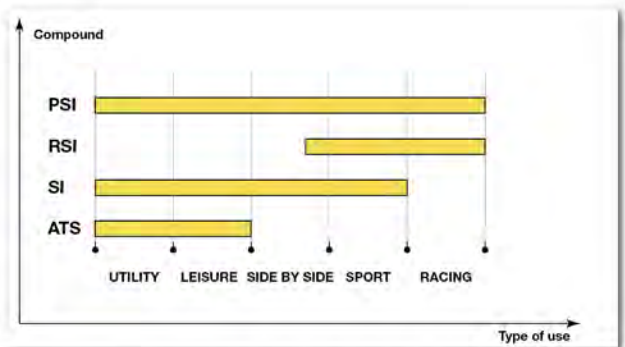

Choose ATS compound for older Arctic Cat and Polaris with plain steel discs.





# CONTENT

2	WELCOME TO SBS
3	BRAKE PADS APPROVED ACCORDING TO ECE R90
4 – 5	NEW! SBS BETTER BRAKES
6	UNIQUE TECHNOLOGY FEATURES
7 – 9	BRAKE PADS STREET
11 – 13	BRAKE PADS AMERICAN
15 – 17	BRAKE PADS SCOOTER
19 – 22	BRAKE PADS RACING
23 – 25	BRAKE PADS OFF ROAD & ATV/UTV
26	BRAKE SHOES WITH SPRINGS
27	BRAKE PINS STAINLESS
28	ACCESSORIES – BRAKE SYSTEM BLEEDER & ANTI-NOISE SHIMS
29	MERCHANDISE
30	RESOURCES
31	CHAMPIONSHIP POSTERS
32	MODEL LOOK-UP WIDGET & COMPOUND SELECTOR WIDGET
33	MOTORCYCLE MODEL APPLICATIONS
34	<i>Motorcycles, Off Road, ATV, Scooters</i>
99	<i>Motocross</i>
105	<i>Racing</i>
109	<i>Calipers</i>
113	BRAKE PAD 1:1 DRAWINGS, COMPOUNDS, FITMENTS
681	CROSSLIST BRAKE PADS: SAME SHAPE – DIFFERENT THICKNESS
685	BRAKE SHOE DRAWINGS, FITMENTS
737	CROSS REFERENCE LIST – OE - SBS
753	BRAKE PIN FITMENTS, DRAWINGS

No se permite la copia total o parcial del catálogo sin el permiso de SBS Friction A/S. La empresa se reserva el derecho a realizar modificaciones en el diseño o aplicaciones para determinados modelos. Se ha realizado un gran esfuerzo para garantizar la exactitud de la información que se incluye en este catálogo. Sin embargo, no nos responsabilizaremos de las pérdidas ocasionadas por errores u omisiones.

Copie complete o parti di questo catalogo sono ammesse soltanto su autorizzazione della SBS Friction A/S. Sono riservati tutti i diritti inerenti a modifiche di progettazione o di modelli di applicazione. È stato compiuto ogni sforzo possibile per garantire la correttezza delle informazioni contenute nel presente catalogo. Tuttavia non risponderemo di eventuali perdite derivanti da errori od omissioni.



## BIENVENIDO A SBS



SBS Friction A/S es una empresa danesa que desarrolla, fabrica y comercializa pastillas de freno y soluciones de fricción para motocicletas, scooter, ATV/UTV, coches especiales y aplicaciones industriales, incluidos generadores eólicos.

Nuestra gama de productos incluye también componentes como discos de freno, zapatas de freno y otros accesorios (por ejemplo, tornillos de freno).

Nuestra historia se remonta a 1964. En la década de 1970 fuimos los primeros en introducir las pastillas de freno de disco en el mercado de piezas de repuesto para motocicletas. Desde entonces hemos seguido ampliando nuestra gama de productos hasta cubrir la práctica totalidad del mercado, con independencia de la marca, el modelo o el año de fabricación. Somos los primeros en ofrecer las novedades y los últimos en retirar los productos más antiguos.

Además de ser el número 1 en el mercado europeo de piezas de repuesto para pastillas de freno de motocicletas, SBS es sinónimo de excelencia en sistemas de frenado en todo el mundo. Nuestra red de distribución se extiende por unos 50 países de todo el mundo, entre ellos Estados Unidos, Canadá, Japón, Australia, Singapur, Sudáfrica y toda la Unión Europea.

Nuestra cartera de clientes incluye fabricantes de equipos originales para motocicletas (por ejemplo, sistemas de frenos) y fabricantes de vehículos, además de fabricantes de otros sectores de la industria, como fabricantes de generadores eólicos, gracias a nuestros conocimientos específicos en materia de fricción.

En nuestra sede de Svendborg (Dinamarca) se encuentran los departamentos de I+D, producción y ventas. Nuestra planta de cerca de 12 000 m<sup>2</sup> incorpora líneas de producción de componentes de material cerámico, sinterizado y carbono.

Nuestra plantilla está integrada por cerca de 200 empleados y nuestra facturación ha aumentado de manera constante desde que presentamos nuestra primera pastilla de freno. En la actualidad somos líderes del mercado.

Adelante. Tenemos la fuerza para detenerle.

## BENVENUTI IN SBS



La SBS Friction A/S è una società danese che sviluppa, produce e commercializza pastiglie dei freni e soluzioni di attrito per moto, scooter, quad e UTV, vetture speciali e applicazioni industriali, comprese le turbine eoliche.

Inoltre, la nostra gamma di prodotti comprende altri componenti per freni quali i dischi dei freni, le ganasce dei freni e accessori quali i perni dei freni.

La nostra storia risale al 1964. Negli anni '70 siamo stati i primi ad introdurre le pastiglie dei freni a disco dei motocicli nel mercato aftermarket. Da allora abbiamo continuamente espanso la nostra gamma di prodotti e attualmente copriamo quasi tutti i segmenti del mercato, indipendentemente da marca, modello o anno di costruzione. Siamo i primi ad avere i prodotti più nuovi e gli ultimi con i prodotti meno recenti.

Siamo il numero 1 nell'aftermarket europeo delle pastiglie dei freni per motociclette, e in tutto il mondo il nome SBS è sinonimo di eccellenza di frenata. In totale, la nostra rete di distribuzione è diffusa in circa 50 paesi in tutto il mondo, tra cui Stati Uniti, Canada, Giappone, Australia, Singapore, Sudafrica e l'intera Unione Europea.

Il nostro portafoglio clienti comprende OEM dell'industria motociclistica, come i produttori di impianti frenanti e di veicoli, e grazie al nostro know-how specialistico in materia di attrito vengono supportati anche altri settori, come i produttori di turbine eoliche.

La nostra sede centrale, il reparto di R&S, la produzione e le vendite si trovano a Svendborg, in Danimarca. Il nostro stabilimento di produzione di circa 12.000 m<sup>2</sup> comprende linee di produzione per componenti in ceramica, materiali sinterizzati e al carbonio.

Abbiamo circa 200 dipendenti e il nostro fatturato è aumentato costantemente da quando abbiamo introdotto la nostra prima pastiglia dei freni. Oggi siamo leader di mercato.

Sempre avanti - Abbiamo la potenza per fermarti!





## PASTILLAS DE FRENO CON HOMOLOGACIÓN ECE R90



En el reglamento ECE R90 se especifican tanto los requisitos de diseño, fabricación y rendimiento como los protocolos de prueba de las piezas de los frenos de recambio de los vehículos de motor que circulan por carretera.

En SBS hemos sido los primeros en obtener plena homologación con arreglo al nuevo reglamento ECE R90. En las páginas de producto (páginas 7 - 25) pueden verse los que están marcados con "Homologación ECE R90". Las futuras incorporaciones se diseñarán de manera que cumplan los requisitos de homologación del reglamento ECE R90.

### Su seguridad, su beneficio

El reglamento ECE R90 pone a prueba la sensibilidad a la velocidad y el rendimiento en frío. Como la guarnición forma parte del sistema de frenado y convierte la energía cinética del vehículo en calor, la guarnición debe ser capaz de resistir altas temperaturas sin que se produzca un desgaste excesivo (lo que conlleva sustituciones frecuentes) o desgasificación (causante del desvanecimiento de los frenos, equivalente a una reducción de la potencia de frenado del freno).

Asimismo, el reglamento ECE R90 exige que los productos estén marcados de manera correcta y se precinten los envases.

La aprobación de la fábrica y el equipo de prueba también forman parte de la homologación R90. Esto conlleva la inspección y la acreditación de la fábrica una vez al año por parte de ingenieros. Las instalaciones de pruebas y fabricación de SBS están homologadas.

En la Unión Europea y en los países extraeuropeos que hayan adoptado los reglamentos ECE se exige que las guarniciones de los frenos de recambio tengan la homologación ECE R90.

### Cómo se prueban: aspectos prácticos

Las pastillas de freno se dividen en 3 categorías (A, B y C) dependiendo del área del material de fricción y todos los compuestos se prueban por separado.

En todos los vehículos en los que se recomiendan pastillas de freno concretas, el compuesto debe calcularse en función de la energía cinética para encontrar el vehículo con condiciones más estrictas para las pruebas.

De esta forma, se comprueban todos los compuestos y vehículos y se prueban en pista las combinaciones más exigentes con el fin de ofrecer al consumidor un producto muy seguro y estable.

En resumen, se garantiza un recambio OEM fiable y de calidad.

**Al elegir una pastilla de freno posventa, recomendamos encarecidamente que cuente con la homologación ECE R90. Con SBS tiene la seguridad de que todos nuestros materiales para uso en la circulación se han homologado completamente en todas las formas, aplicaciones de vehículos y compuestos. Póngase en contacto con nuestro Servicio de atención al cliente para obtener más información: sbs@sbs.dk.**

## PASTIGLIE DEI FRENI OMOLOGATE SECONDO ECE R90



Il regolamento ECE R90 specifica i requisiti di progettazione, costruzione e prestazioni, nonché i protocolli di prova per i pezzi di ricambio dei freni per gli autoveicoli che circolano su strada.

SBS, come industria, ha ricevuto per la prima volta l'omologazione completa secondo il nuovo regolamento ECE R90. Sulle pagine dei prodotti (pagine 7 - 25) è possibile controllare quali sono contrassegnati con la dicitura "Omologato ECE R90". Tutti i prodotti introdotti in futuro sono progettati per soddisfare l'omologazione del regolamento ECE R90.

### La vostra sicurezza - i vostri vantaggi

ECE R90 testa la sensibilità alla velocità e le prestazioni a freddo. Dato che il rivestimento fa parte dell'impianto frenante che converte l'energia cinetica del veicolo in calore, il rivestimento deve essere in grado di resistere a temperature elevate senza usura eccessiva (col risultato di frequenti sostituzioni), oppure degassamento (che causa il fading, una perdita della potenza frenante).

Inoltre, l'ECE R90 richiede la corretta marcatura dei prodotti e degli imballaggi sigillati.

L'omologazione R90 comprende anche l'approvazione delle attrezzature di prova e di fabbrica. Questo comporta l'ispezione e l'accreditamento della fabbrica da parte di ingegneri una volta all'anno. Naturalmente SBS dispone dell'approvazione sia per gli impianti di produzione che per quelli di prova.

L'omologazione secondo la norma ECE R90 è richiesta per tutti i rivestimenti freni di ricambio in tutta l'Unione Europea e nei paesi non europei che hanno adottato i regolamenti ECE.

### Come effettuare i test - cosa avviene in pratica

Le pastiglie dei freni sono suddivise in 3 categorie - A, B e C - a seconda dell'area del materiale di attrito, e tutte le mescole sono testate singolarmente.

Tutti i veicoli raccomandati per la specifica mescola delle pastiglie dei freni devono essere valutati in base all'energia cinetica per individuare il veicolo più impegnativo da testare.

In questo modo tutte le mescole e i veicoli vengono controllati e le combinazioni più esigenti testate in pista, per consentire al consumatore di ottenere un prodotto estremamente sicuro.

In breve: la vostra garanzia per una qualità di ricambi OEM affidabile.

**Nel momento in cui si sceglie una pastiglia per freni di ricambio Aftermarket, consigliamo vivamente di controllare che sia omologata secondo la normativa ECE R90. Con SBS siete al sicuro - tutti i nostri materiali per uso stradale sono stati completamente approvati per tutte le forme, le applicazioni dei veicoli e le mescole. Per maggiori informazioni consultate il nostro servizio assistenza clienti: sbs@sbs.dk.**







SBS BETTER BRAKES



GO AHEAD

## ¡NUEVO! SBS BETTER BRAKES



SBS presenta un nuevo tipo de compuesto que es más puro en su composición y que presenta unas mejores características de rendimiento. Lo llamamos SBS Better Brakes.

La fecha de transición de la primera serie de productos a los nuevos compuestos HF, HS y MS de SBS Better Brakes es el 1 de enero de 2023. Los nuevos compuestos han sido diseñados pensando en la purificación y el rendimiento. En lugar de latón y níquel, los nuevos compuestos han sido diseñados a partir de una fórmula basada en hierro. Los compuestos HF han sido purificados y no contienen antimonio\*.

**0%** **COPPER** (for Sintered brake pads)  
**NICKEL** (for Sintered brake pads)  
**ANTIMONY** (for Ceramic brake pads)

### EL IDENTIFICADOR

A fin de diferenciar los antiguos de los nuevos, SBS ha introducido el simbólico icono "Better Brakes" en su embalaje. Esto también permitirá que las referencias de los productos (p. ej., 706HS o 146MS) sigan siendo las mismas que hoy para mayor comodidad de los conductores, concesionarios y distribuidores por igual.

### FASE DE TRANSICIÓN

Los primeros productos que pasarán a ser SBS Better Brakes son los HF, HS y MS. La productos SP dejarán de fabricarse a partir del 1 de enero de 2023. Todas las referencias de productos SP se fusionarán con las referencias HS, facilitando de este modo la selección de productos preferentes, que pasará a realizarse en función del principio 'bueno-mejor-el mejor'.

A mitad de 2023, los siguientes en realizar la transición son los productos RQ y CT, seguidos de los productos LS, cuya transición tendrá lugar en 2024.

## NUOVO! SBS BETTER BRAKES



SBS sta presentando una nuovo tipo di mescola dalla composizione più pura e con migliori caratteristiche prestazionali. È stata chiamata SBS Better Brakes.

Il 1° gennaio 2023 segna il lancio della prima serie di prodotti che passano alle nuove mescole SBS Better Brakes, HF, HS e MS. Le nuove mescole sono state studiate in funzione della purezza e delle prestazioni. Le mescole sinterizzate non contengono rame e nichel, ma sono progettate con una formula a base di ferro. Le mescole HF sono purificate e prive di antimonio\*.

### L'IDENTIFICATORE

Per differenziare i prodotti vecchi da quelli nuovi, SBS sta introducendo la simbolica "icona Better Brakes" sulle sue confezioni. Questo anche perché i riferimenti dei prodotti (ad esempio 706HS o 146MS) rimarranno quelli attuali, per la comodità di motociclisti, concessionari e distributori.



### FASE DI TRANSIZIONE

I primi prodotti a passare a SBS Better Brakes sono HF, HS e MS. La produzione di SP cesserà a partire dal 1° gennaio 2023. Tutti i riferimenti dei prodotti SP saranno raggruppati in HS, facilitando la selezione preferita in base al principio "buono-migliore-ottimo".

Il piano di transizione prosegue poi, entro la metà del 2023, con la transizione dei prodotti RQ e CT, seguita da quella dei prodotti LS e, nel 2024, dei prodotti SI.

## TRANSITION TIMELINE Better Brakes

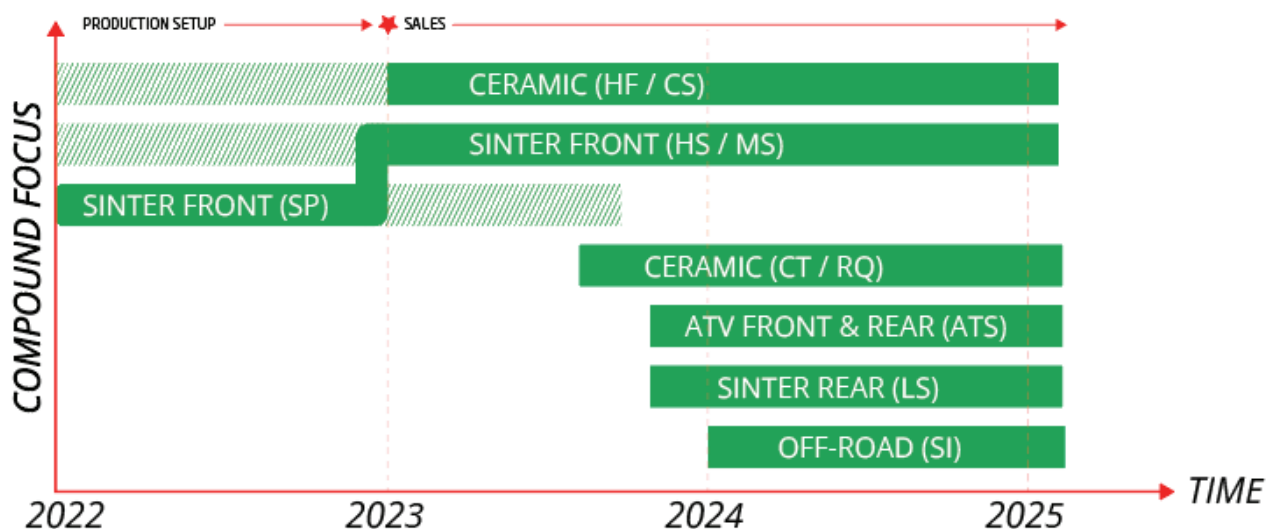

\* Los compuestos pueden contener partículas de polvo que podrían, o no, contener niveles de cobre, níquel y antimonio. La terminología de compuestos no incluye los recubrimientos de las placas de freno.

\* Le mescole possono contenere particelle di polvere che possono o meno contenere livelli di rame, nichel e antimonio. La terminologia della mescola non comprende i rivestimenti della piastra di supporto.





SBS BETTER BRAKES



## ¡NUEVO! SBS BETTER BRAKES



### CARACTERÍSTICAS DE RENDIMIENTO MEJORADO

Los productos SBS ofrecen 'Excelencia de frenado', y eso también incluye a los nuevos SBS Better Brakes. Nada menos.

#### Potencia de detención mejorada (gráfico 1)

SBS Better Brakes permite mejorar la maniobrabilidad en situaciones de emergencia. La composición metálica de los compuestos permite mejorar el coeficiente de fricción, lo que genera un agarre más eficiente del freno a lo largo de toda la secuencia de frenado. El resultado es una potencia de detención optimizada equivalente al 9-12 % en distancias de frenado.

#### Índice de rendimiento (gráfico 2)

Los conductores experimentarán una resistencia al desgaste parecida, pero con una sensación de agarre y una estabilidad de rendimiento ampliamente mejoradas a lo largo del espectro de temperaturas. Esto significa que los conductores experimentarán un coeficiente de respuesta 1:1 entre el agarre de la palanca y la reducción de la velocidad.

#### Rendimiento térmico (gráfico 3)

El nuevo compuesto SBS Better Brakes ha sido diseñado para mantener el rendimiento incluso en situaciones de frenado intenso. El conductor medio suele frenar en un espectro térmico del disco de entre 100 y 300 grados, lo que significa que experimentará un frenado consistente a lo largo de toda la conducción y de toda la gama térmica.

#### Rendimiento antifundido (gráfico 4)

Los conductores experimentarán un rendimiento mejorado tanto al principio como durante la conducción, independientemente del calentamiento del sistema de frenos. Los conductores también tendrán una sensación de agarre general optimizada y de un primer agarre inicial mejorado en el momento de frenar.

### Improved stopping power (graph 1)

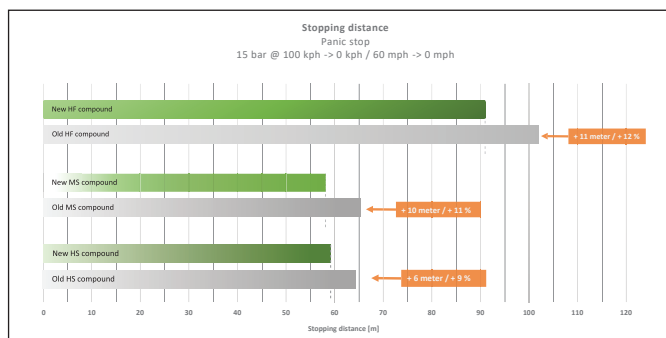

Brake length HS + HF + MS vs. old

### Performance rating (graph 2)

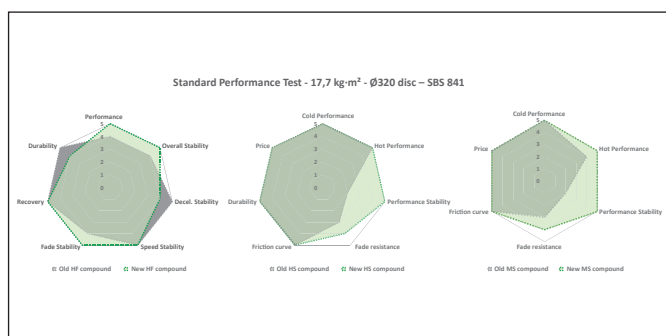

Performance rating HS + HF + MS vs. old

## NUOVO! SBS BETTER BRAKES



### CARATTERISTICHE PRESTAZIONALI MIGLIORATE

Con SBS potete aspettarvi l'eccellenza della frenata, compresi i nuovi freni SBS Better Brakes. Niente di meno.

#### Potere di arresto migliorato (grafico 1)

SBS Better Brakes consentono una migliore manovrabilità in situazioni di emergenza. I metalli presenti nelle mescole consentono di migliorare il coefficiente di attrito, che si traduce in una presa più efficiente dei freni durante l'intera sequenza di frenata. L'effetto è un miglioramento della potenza di arresto equivalente al 9-12% dello spazio di frenata.

#### Valutazione delle prestazioni (grafico 2)

I motociclisti possono aspettarsi un profilo di usura simile e un senso di aderenza e stabilità delle prestazioni complessivamente migliorato con ogni temperatura. Ciò significa che i motociclisti possono aspettarsi una reattività 1:1 tra la presa della leva e la riduzione della velocità.

#### Prestazioni termiche (grafico 3)

La nuova mescola SBS Better Brakes è stata progettata per mantenere le prestazioni anche in situazioni di frenata intensa. Il guidatore medio si trova spesso in uno spettro di calore compreso tra i 100 e i 300 gradi del disco. I motociclisti medi possono aspettarsi un'esperienza di frenata costante per tutta la durata del viaggio, in tutto lo spettro di calore.

#### Prestazioni fading (grafico 4)

I motociclisti possono aspettarsi un miglioramento delle prestazioni all'inizio e per tutta la durata della corsa, nonostante il riscaldamento dell'impianto frenante. I motociclisti otterranno anche una migliore sensazione di aderenza e un migliore presa iniziale in frenata.

### Heat performance (graph 3)

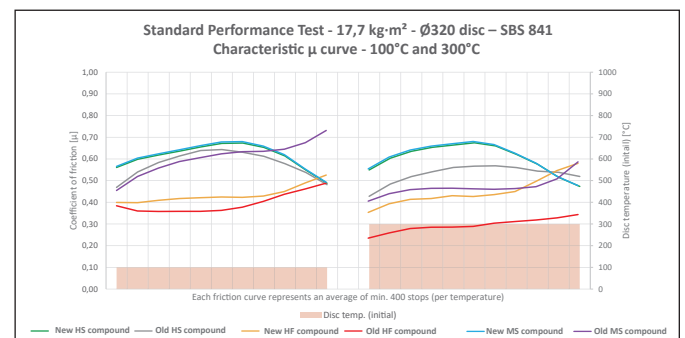

Heat performance HS + HF + MS vs. old

### Fade Performance (graph 4)

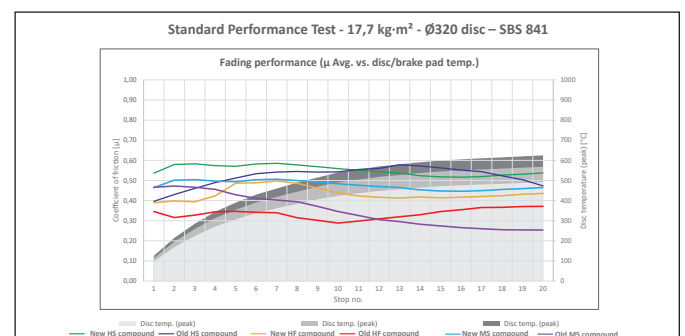

Fading performance HS + HF + MS vs. old



## CARACTERÍSTICAS TECNOLÓGICAS UNICAS



### NRS TECHNOLOGY (NUCAP RETENTION SYSTEM)

¡SBS implementa la tecnología NRS 100 % segura! Las pastillas de freno conductoras y sinterizadas están totalmente reforzadas con la tecnología de unión NRS, la más avanzada del mercado. El sistema de retención NUCAP (NRS) es un proceso patentado en el que la superficie de la placa de soporte se ha modificado con una matriz de ganchos de acero que facilitan una unión mecánica indestructible entre la pastilla de freno y el material de fricción, sin necesidad de usar ningún tipo de adhesivos.

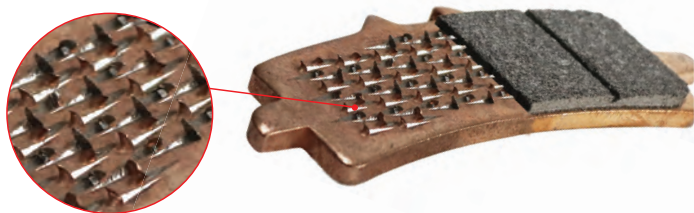

En comparación con los métodos de unión tradicionales, las ventajas principales de la tecnología NRS son:

- // No hay separación entre la placa de soporte y el material de fricción
- // El material de fricción no presenta bordes elevados que generen sensación de palanca firme
- // No hay vibraciones entre el material de fricción y la placa de soporte

### TAMBIÉN PARA COMPETICIÓN

Como único fabricante de pastillas para competición, desde la introducción del Doble Carbono (DC) en 2001 y la Doble Sinterización (DS) en 2007, SBS ha empleado la tecnología NRS para los compuestos tanto de carbono como de base sinterizada. Se ha desarrollado una nueva versión de NRS capaz de responder a las expectativas de rendimiento de las pastillas de freno SBS para competición.

### EL IDENTIFICADOR



Los productos con tecnología NRS pueden identificarse como tal gracias al distintivo NRS situado en la parte inferior del embalaje.

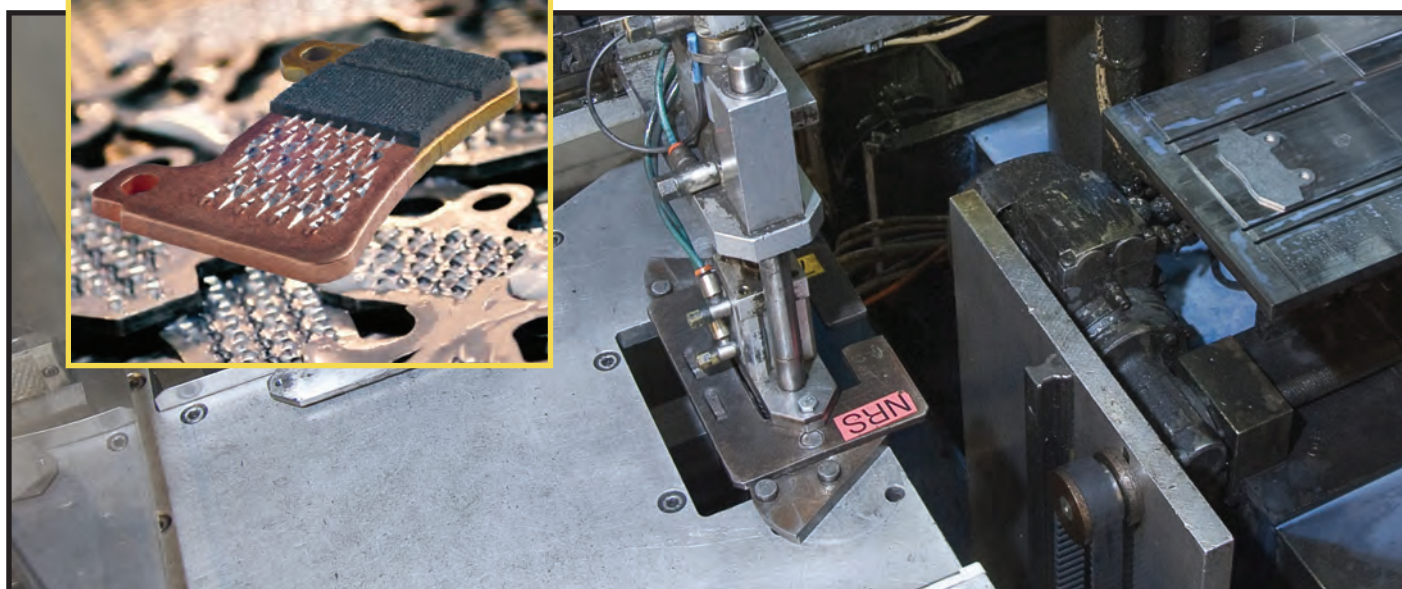

## CARATTERISTICHE DI UNA TECNOLOGIA ESCLUSIVA



### NRS TECHNOLOGY (NUCAP RETENTION SYSTEM)

SBS offre sicurezza NRS al 100%! Le pastiglie per freni conduttive e sinterizzate SBS sono tutte realizzate con la tecnologia di incollaggio più avanzata del mercato, NRS. Il sistema di ritenzione NUCAP (NRS) è un processo brevettato in cui la superficie della piastra di supporto viene modificata con una matrice di ganci in acciaio che permettono un legame meccanico indistruttibile tra la piastra di supporto della pastiglia e il materiale di attrito, senza l'uso di adesivi.

I principali vantaggi della tecnologia NRS rispetto ai metodi di incollaggio tradizionali sono:

- // Nessuna separazione tra piastra di supporto e materiale di attrito
- // Nessuno spigolo sollevato nel materiale di attrito, con conseguente sensazione di una leva solida
- // Nessuna vibrazione tra materiale di attrito e piastra di supporto

### ANCHE PER LE CORSE

Unico produttore di pastiglie da corsa, SBS utilizza la tecnologia NRS sia per le mescole al carbonio che per quelle sinterizzate sin dall'introduzione di DC Dual Carbon nel 2001 e di DS Dual Sinter nel 2007. È stata sviluppata una versione speciale di NRS per assicurare anche nel mondo delle competizioni le alte prestazioni che ci si aspetta dalle pastiglie freno SBS.

### L'IDENTIFICATORE



I prodotti con NRS sono riconoscibili dal contrassegno NRS sulla parte inferiore della confezione.





# LICENSE TO ADVENTURE

## #STREETMOTORCYCLE



Si prefieres la motocicleta de calle. Si reserva los fines de semana y las vacaciones para el turismo y la aventura. Si disfruta de la libertad que da pilotar una motocicleta. O si utiliza la motocicleta a diario.

Entonces, las pastillas de freno SBS STREET son perfectas para usted. Nuestros compuestos STREET se adecuan a motocicletas de calle de todas las marcas, modelos y años que hay en el mercado, sin excepción.

Todas las pastillas de freno tienen la homologación ECE R90.

Ofrecen el rendimiento, la duración y el confort que necesita para SEGUIR ADELANTE.

Puede elegir entre:  
// PERFORMANCE – HS / LS  
// STANDARD – HF

Para acertar con las pastillas de su motocicleta, siga nuestras recomendaciones.



Se la tua scelta preferita è una moto da strada. Se ti dedichi ai viaggi e alle avventure nei fine settimana e durante le vacanze. Se ti piace la libertà di guidare la moto. O se ogni giorno fai il pendolare.

Allora le pastiglie dei freni STREET SBS sono la scelta giusta per te. Le nostre mescole STREET sono sviluppate per tutte le marche, i modelli e gli anni di fabbricazione delle moto da strada presenti sul mercato –per pastiglie sia anteriori sia posteriori.

Tutte le pastiglie dei freni sono omologate ECE R90.

Ti garantiscono le prestazioni, la durata ed il comfort che ti servono per partire.

Scegli tra:  
// PERFORMANCE – HS / LS  
// STANDARD – HF

Segui i nostri consigli sulle pastiglie ideali per la tua moto.

**sbs**<sup>®</sup>  
GO AHEAD





# PERFORMANCE



## HS - SINTER

DELANTE / ANTERIORI



- // Compuesto de recambio original y mejorado para motocicletas con pastillas sinterizadas
- // Diseñado para utilizarse en motocicletas modernas de altas prestaciones, deportivas, gran turismo y adventure
- // Compuesto sinterizado formulado para garantizar poco desgaste, alta estabilidad térmica, excelente sensación de frenado y fácil modulación
- // Líder en el sector y alto rendimiento, desarrollado en competición y adaptado para el uso en la calle
- // Excelente para rotores/discos de freno de acero inoxidable o hierro fundido
- // Compuestos delantero (HS) y trasero (LS) que permiten un reparto de la frenada perfecto para evitar el bloqueo de la rueda trasera
- // Parte de la nueva transición SBS Better Brakes



- // Composto per migliorare e sostituire il prodotto OE per moto con pastiglie sinterizzate
- // Studiato per moto moderne ad alte prestazioni, sport, touring e adventure
- // Composto sinterizzato formulato per una usura ridotta, elevata stabilità termica, sensazione di frenata eccellente e modulazione facile
- // Prodotto leader nella categoria e ad elevate prestazioni, sviluppato nelle competizioni e messo a punto per l'uso su strada
- // Eccellente per rotori/dischi freni in acciaio inox o ghisa
- // Composti per freni anteriori (HS) e posteriori (LS) per un bilanciamento ideale e per evitare il bloccaggio della ruota posteriore
- // Parte della nuova transizione SBS Better Brakes



Diagramas de potencia de freno para comparar de forma individual los compuestos de STREET exclusivamente.



## LS - SINTER

POSTERIOR / POSTERIORI



- // Compuesto de recambio original para motocicletas con pastillas sinterizadas
- // Diseñado para utilizarse en motocicletas modernas de altas prestaciones, motocicletas deportivas y gran turismo
- // Compuesto sinterizado que ofrece resultados predecibles y controlables en la rueda trasera
- // Exclusivo compuesto para la rueda trasera formulado según el concepto del fabricante original, que ofrece un perfecto reparto de la frenada entre la parte delantera y la trasera para evitar frenadas bruscas y el bloqueo de la rueda trasera
- // Parte de la nueva transición SBS Better Brakes



- // Composto per sostituire il prodotto OE per moto con pastiglie sinterizzate
- // Studiato per moto moderne ad alte prestazioni, sport, touring grandi
- // Composto sinterizzato che offre prestazioni prevedibili e controllabili, per la ruota posteriore
- // Composto esclusivo per ruota posteriore formulato secondo un concetto OEM che offre un bilanciamento ideale dei freni anteriori / posteriori, per evitare frenate eccessive ed il bloccaggio della ruota posteriore
- // Parte della nuova transizione SBS Better Brakes



Diagrammi di prestazione dei freni da confrontare singolarmente con le sole mescole STREET.





STREET BRAKE PADS

sbs®

GO AHEAD

## STANDARD



R90



BETTER BRAKES

### HF - CERAMIC

DELANTE / ANTERIORI • POSTERIOR / POSTERIORI



- // Compuesto de recambio original para motocicletas con pastillas no sinterizadas
- // Diseñado para motocicletas urbanas, motocicletas de calle polivalentes y cruisers,
- // Compuesto cerámico que garantiza una larga duración de la pastilla, poco polvo y un menor desgaste del rotor/disco de freno
- // Prestaciones excelentes y uniformes tanto en seco como en mojado
- // Tecnología NUCAP NRS que garantiza una adherencia mecánica e indestructible del compuesto
- // Innovadora tecnología de reducción del ruido que mejora el confort y reduce la emisión de ruido
- // Parte de la nueva transición SBS Better Brakes



- // Composto per sostituire il prodotto OE per moto con pastiglie non sinterizzate
- // Studiato per moto cruiser, per uso generico su strada e per andare al lavoro
- // Il composto ceramico offre una lunga durata delle pastiglie, bassa polverosità e una ridotta usura del rotore/disco freni
- // Prestazioni eccellenti e costanti in condizioni di asciutto e bagnato
- // La tecnologia NRS NUCAP garantisce un fissaggio meccanico ed indistruttibile del composto
- // Tecnologia per la riduzione della rumorosità; per il massimo comfort e la minima generazione di rumore
- // Parte della nuova transizione SBS Better Brakes

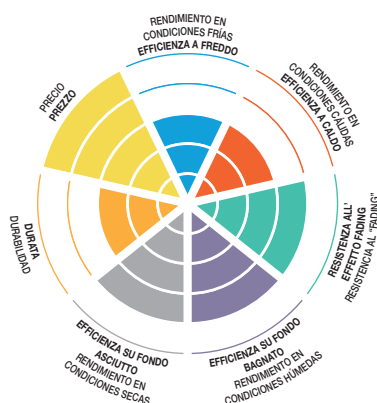

Diagrammi di prestazione dei freni da confrontare singolarmente con le sole mescole STREET.











# LICENSE TO FREEDOM

## #VTWIN



Si le apasiona el estilo de vida americano y el diseño y las características exclusivas de marcas de motocicletas tan legendarias como Harley Davidson, Buell e Indian, SBS tiene los frenos que necesita.

Nuestra gama de pastillas de freno creada especialmente para las motocicletas americanas incorpora compuestos que combinan alta potencia con poco ruido y larga vida útil. Nuestra gama abarca tanto los modelos clásicos de la década de 1980 como los modelos más modernos de motocicletas americanas.

Todas las pastillas de freno tienen la homologación ECE R90.

Puede elegir entre:

- // HIGH PERFORMANCE & NO DUST – H.HS / H.LS
- // HIGH POWER & NOISE REDUCTION FORMULA – H.CT
- // ULTRA QUIET & LOW DUST – H.HF

Para acertar con las pastillas de su motocicleta, siga nuestras recomendaciones.



Se sei appassionato dello stile di vita americano, e del design e delle caratteristiche esclusive di famose marche di moto americane come Harley Davidson, Buell e Indian, allora SBS ha la risposta per le tue esigenze di freni.

La nostra gamma di pastiglie dei freni studiate appositamente per moto americane è caratterizzata da mescole che uniscono elevata potenza con bassa rumorosità e lunga durata. La nostra gamma è completa - sia per modelli vintage risalenti agli anni '80 che per moto americane di produzione attuale.

Tutte le pastiglie dei freni sono omologate ECE R90.

Scegli tra:

- // HIGH PERFORMANCE & NO DUST – H.HS / H.LS
- // HIGH POWER & NOISE REDUCTION FORMULA – H.CT
- // ULTRA QUIET & LOW DUST – H.HF

Segui i nostri consigli sulle pastiglie ideali per la tua moto.







# HIGH PERFORMANCE & NO DUST



## H.HS - SINTER

DELANTE / ANTERIORI

- // Compuesto de recambio original y mejorado para motocicletas con pastillas sinterizadas
- // Diseñado para utilizarse en motocicletas modernas de altas prestaciones, motocicletas deportivas y gran turismo
- // Compuesto sinterizado formulado para garantizar poco desgaste, alta estabilidad térmica y excelente sensación de frenado
- // Excelente para rotores/discos de freno de acero inoxidable o hierro fundido
- // Compuestos delantero (H.HS) y trasero (H.LS) que permiten un reparto de la frenada perfecto para evitar el bloqueo de la rueda trasera
- // Parte de la nueva transición SBS Better Brakes

- // Composto per migliorare e sostituire il prodotto OE per moto con pastiglie sinterizzate
- // Studiato per moto moderne ad alte prestazioni, sport, touring grandi
- // Composto sinterizzato formulato per una usura ridotta, elevata stabilità termica e sensazione di frenata eccellente
- // Eccellente per rotori/dischi freni in acciaio inox o ghisa
- // Composti per freni anteriori (H.HS) e posteriori (H.LS) per un bilanciamento ideale e per evitare il bloccaggio della ruota posteriore
- // Parte della nuova transizione SBS Better Brakes

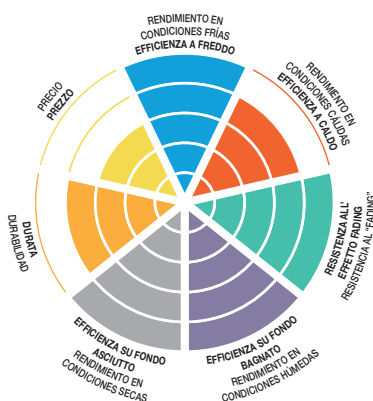

Diagramas de potencia de freno para comparar de forma individual los compuestos de AMERICAN exclusivamente.



## H.LS - SINTER

POSTERIOR/ POSTERIOR

- // Compuesto de recambio original para motocicletas con pastillas sinterizadas
- // Diseñado para utilizarse en motocicletas modernas de altas prestaciones, motocicletas deportivas y gran turismo
- // Compuesto sinterizado que ofrece resultados predecibles y controlables en la rueda trasera
- // Exclusivo compuesto para la rueda trasera formulado según el concepto del fabricante original, que ofrece un perfecto reparto de la frenada entre la parte delantera y la trasera para evitar frenadas bruscas y el bloqueo de la rueda trasera
- // Parte de la nueva transición SBS Better Brakes

- // Composto per sostituire il prodotto OE per moto con pastiglie sinterizzate
- // Studiato per moto moderne ad alte prestazioni, sport, touring grandi
- // Composto sinterizzato che offre prestazioni prevedibili e controllabili, per la ruota posteriore
- // Composto esclusivo per ruota posteriore formulato secondo un concetto OEM, per offrire un bilanciamento ideale dei freni anteriori / posteriori, evitare frenate eccessive ed il bloccaggio della ruota posteriore
- // Parte della nuova transizione SBS Better Brakes



Diagrammi di prestazione dei freni da confrontare singolarmente con le sole mescole AMERICAN.





AMERICAN BRAKE PADS



GO AHEAD

## HIGH POWER & NOISE REDUCTION FORMULA / ULTRA QUIET & LOW DUST



### H.CT - CARBON

DELANTE / ANTERIORI • POSTERIOR / POSTERIORI



- // Compuesto con mejora de rendimiento, excelente para motocicletas con discos y sistemas de frenos personalizados
- // Compatible con discos de freno de acero inoxidable, hierro fundido, cromados y pulidos
- // Prestaciones HH, desarrollado en competición y adaptado para el uso en la calle
- // Sensación y control inigualables en la maneta de freno tanto en seco como en mojado
- // Tecnología NUCAP NRS que garantiza una adherencia mecánica e indestructible del compuesto
- // Ruido reducido
- // Parte de la nueva transición SBS Better Brakes



- // Composto per il miglioramento delle prestazioni, eccellente per moto con dischi e impianto freni personalizzato
- // Compatibile con dischi freni in acciaio inox, ghisa, cromati e bruniti
- // Prodotto classificato HH, sviluppato nelle competizioni e messo a punto per l'uso su strada
- // Controllo e sensazione ineguagliabili nella leva del freno in condizioni di asciutto e bagnato
- // La tecnologia NRS NUCAP garantisce un fissaggio meccanico ed indistruttibile del composto
- // Rumore ridotto
- // Parte della nuova transizione SBS Better Brakes

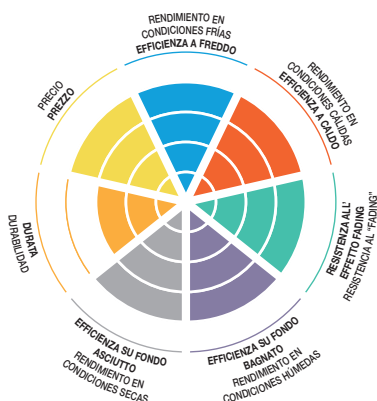

Diagramas de potencia de freno para comparar de forma individual los compuestos de AMERICAN exclusivamente.



### H.HF - CERAMIC

DELANTE / ANTERIORI • POSTERIOR / POSTERIORI



- // Compuesto de recambio original para motocicletas con pastillas no sinterizadas
- // Diseñado para motocicletas urbanas, motocicletas de calle polivalentes y cruisers
- // Compuesto cerámico que garantiza una larga duración de la pastilla, poco polvo y un menor desgaste del rotor/disco de freno
- // Prestaciones excelentes y uniformes tanto en seco como en mojado
- // Tecnología NUCAP NRS que garantiza una adherencia mecánica e indestructible del compuesto
- // Innovadora tecnología de reducción del ruido que mejora el confort y reduce la emisión de ruido
- // Parte de la nueva transición SBS Better Brakes



- // Composto per sostituire il prodotto OE per moto con pastiglie non sinterizzate
- // Studiato per moto cruiser, per uso generico su strada e per andare al lavoro
- // Il composto ceramico offre una lunga durata delle pastiglie, bassa polverosità e una ridotta usura del rotore/disco freni
- // Prestazioni eccellenti e costanti in condizioni di asciutto e bagnato
- // La tecnologia NRS NUCAP garantisce un fissaggio meccanico ed indistruttibile del composto
- // Tecnologia per la riduzione della rumorosità; per il massimo comfort e la minima generazione di rumore
- // Parte della nuova transizione SBS Better Brakes

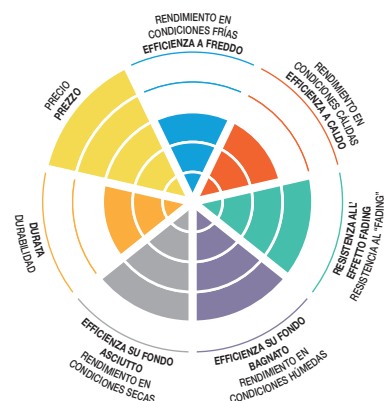

Diagrammi di prestazione dei freni da confrontare singolarmente con le sole mescole AMERICAN.





87



# LICENSE TO HAVE FUN

## #URBANMOBILITY



El scooter suele ser el vehículo perfecto para desplazarse por la ciudad. Con tráfico denso, es esencial disponer de unos frenos fiables. Las pastillas de freno para scooter de SBS ofrecen unas prestaciones de frenado y una durabilidad perfectas en ciudad.

Ofrecemos compuestos diferentes que se adecuan a la mayoría de los tipos de scooter y de las necesidades de conducción. Tenemos una oferta comercial amplia que incluye pastillas y compuestos para diferentes modelos, desde scooters pequeños de 50 cc hasta maxi scooters modernos de altas prestaciones.

La mayoría de las pastillas de freno tienen la homologación ECE R90.

Puede elegir entre:

- // MAXI SINTER – MS
- // STANDARD & MAXI – CT
- // STANDARD & MAXI – HF

Para acertar con las pastillas de su scooter, siga nuestras recomendaciones.



Spesso uno scooter è l'ideale quando ci si deve spostare in città. Ma in mezzo al traffico, devi poterti fidare dei tuoi freni. Le pastiglie dei freni Scooter SBS offrono le prestazioni di frenata e durata ideali per queste condizioni.

Offriamo diverse mescole per la maggior parte dei tipi di scooter e per le varie esigenze di guida. La nostra copertura di mercato è ampia con pastiglie e mescole dai modelli piccoli da 50 cc fino ai moderni maxi scooter ad alte prestazioni.

La maggior parte delle pastiglie dei freni sono omologate ECE R90.

Scegli tra:

- // MAXI SINTER – MS
- // STANDARD & MAXI – CT
- // STANDARD & MAXI – HF

Segui i nostri consigli sulle pastiglie ideali per la tua moto.

**sbs**<sup>®</sup>  
GO AHEAD



SCOOTER BRAKE PADS



GO AHEAD

## MAXI SINTER / STANDARD & MAXI



### MS - SINTER

DELANTE / ANTERIORI • POSTERIOR / POSTERIORI



- // Compuesto sinterizado mejorado de alto rendimiento para maxi scooters (de 250 cc en adelante)
- // Recomendado para maxi scooters con tecnología de motocicleta
- // Compuesto sinterizado de vanguardia formulado para garantizar poco desgaste, alta estabilidad térmica y excelente sensación de frenado
- // Parte de la nueva transición SBS Better Brakes



- // Composto sinterizzato migliorato ad alte prestazioni per maxi scooter a partire da 250 cc<sup>3</sup>
- // Consigliato per maxi scooter con tecnologia da moto
- // Composto sinterizzato avanzato formulato per una usura ridotta, elevata stabilità termica e sensazione di frenata eccellente
- // Parte della nuova transizione SBS Better Brakes

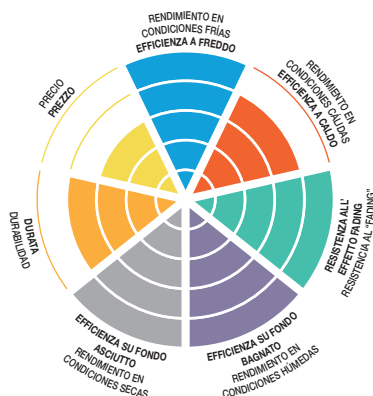

Diagramas de potencia de freno para comparar de forma individual los compuestos de SCOOTER exclusivamente.



### CT - CARBON

DELANTE / ANTERIORI • POSTERIOR / POSTERIORI



- // Compuesto de carbono con mejora de rendimiento para scooters de tamaño mediano (125-249 cc)
- // Recomendado para pilotaje deportivo, transporte diario y entretenimiento
- // Tecnología NUCAP NRS que garantiza una adherencia mecánica e indestructible del compuesto
- // Parte de la nueva transición SBS Better Brakes



- // Composto al carbonio per migliorare le prestazioni per scooter medi da 125-249 cc<sup>3</sup>
- // Consigliato per la guida sportiva, il trasporto di tutti i giorni ed il divertimento
- // La tecnologia NRS NUCAP garantisce un fissaggio meccanico ed indistruttibile del composto
- // Parte della nuova transizione SBS Better Brakes

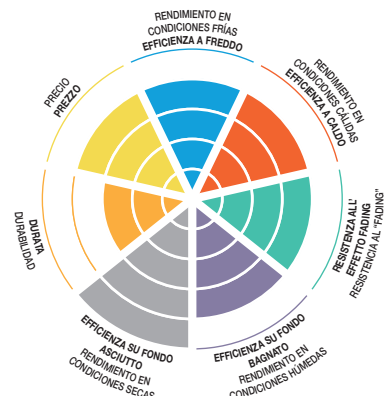

Diagrammi di prestazione dei freni da confrontare singolarmente con le sole mescole SCOOTER.





SCOOTER BRAKE PADS



GO AHEAD

## STANDARD & MAXI



### HF - CERAMIC

DELANTE / ANTERIORI • POSTERIOR / POSTERIORI



- // Compuesto cerámico de recambio original para scooters de tamaño pequeño y mediano (50-124 cc)
- // Recomendado para pilotar motocicletas urbanas y motocicletas de calle polivalentes
- // Tecnología NUCAP NRS que garantiza una adherencia mecánica e indestructible del compuesto
- // Parte de la nueva transición SBS Better Brakes



- // Composto ceramico per sostituire il prodotto OE per scooter piccoli e medi da 50-124 cc<sup>3</sup>
- // Consigliato per uso generico su strada e per andare al lavoro
- // La tecnologia NRS NUCAP garantisce un fissaggio meccanico ed indistruttibile del composto
- // Parte della nuova transizione SBS Better Brakes

Diagramas de potencia de freno para comparar de forma individual los compuestos de SCOOTER exclusivamente.

Diagrammi di prestazione dei freni da confrontare singolarmente con le sole mescole SCOOTER.

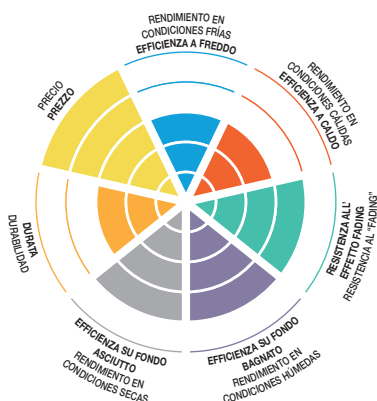



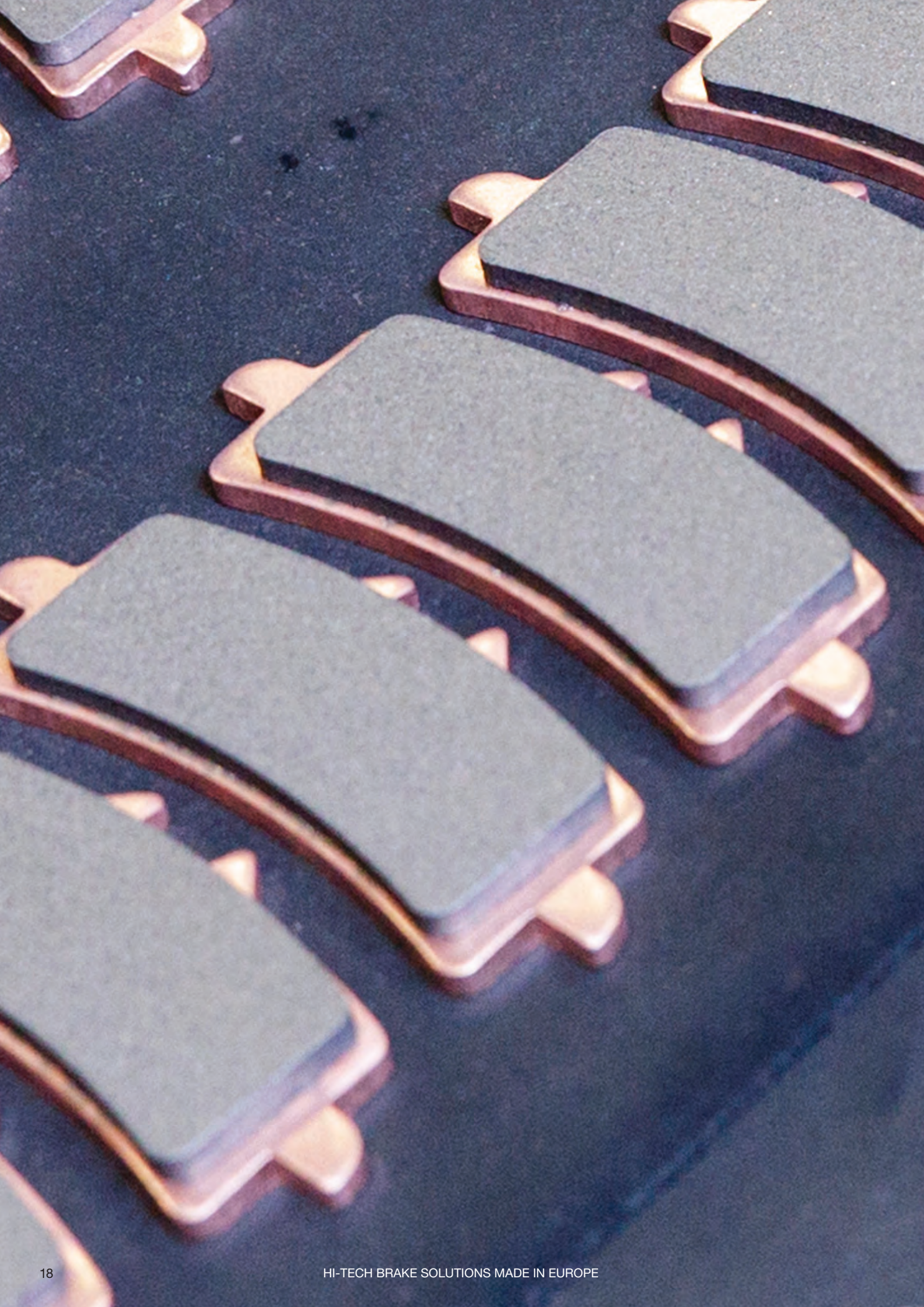



# LICENSE TO WIN #ROADRACING



**TOMMY BRIDEWELL**  
PBM BEERMONSTER DUCATI TEAM  
BRITISH SUPERBIKE CHAMPION 2023



Las carreras forman parte de nuestro ADN desde hace más de 25 años.

A través de nuestros colaboradores del Racing concept, ofrecemos potencia de frenado a los mejores pilotos de competición del mundo. Ya se trate carreras internacionales de primer nivel, como Superbike, Supersport o Endurance, competiciones nacionales, tandas en circuito o carreras clásicas en carretera, SBS ofrece pastillas de freno con las que se pueden ganar centésimas de segundo importantes durante la frenada. Nuestros compuestos de carreras se han desarrollado especialmente para el uso en competición y en circuitos de carreras. Han sido probados y aprobados por algunos de los mejores pilotos del Campeonato del Mundo.

Las pastillas de carreras no pueden tener la homologación ECE R90. Salvo LS, todas las pastillas de carreras se realizan con tecnología NUCAP NRS.

Puede elegir entre:

- // DYNAMIC RACING CONCEPT – DS-1 & DS-2
- // ROAD RACING & CLASSIC RACING – DC / DCC
- // ROAD RACING & TRACK DAYS – RS
- // RACING REAR – RQ / LS

Para acertar con las pastillas de su motocicleta, siga nuestras recomendaciones.



Le competizioni fanno parte del nostro DNA da oltre 25 anni.

Attraverso il nostro concept Partners in Racing, assicuriamo la potenza di arresto ai migliori piloti del campionato del mondo. Sia che si tratti di gare internazionali di alto livello come Superbike, Supersport o Endurance, competizioni nazionali, giornate in pista o corse classiche su strada, SBS ti offre le pastiglie dei freni necessarie per assicurarti importanti centesimi di secondo in frenata. Le nostre mescole da gara sono sviluppate appositamente per le competizioni e per l'uso in pista - testate e approvate da alcuni dei migliori piloti del Campionato del Mondo.

Le pastiglie per le gare più esasperate non possono essere omologate ECE R90. Tutte le pastiglie per gare oltre a LS sono rinforzate con la tecnologia NUCAP NRS.

Scegli tra:

- // RDYNAMIC RACING CONCEPT – DS-1 & DS-2
- // ROAD RACING & CLASSIC RACING – DC / DCC
- // ROAD RACING & TRACK DAYS – RS
- // RACING REAR – RQ / LS

Segui i nostri consigli sulle pastiglie ideali per la tua moto.

**sbs**<sup>®</sup>  
GO AHEAD





RACING BRAKE PADS



GO AHEAD

# PROFESSIONAL RACING / ENDURANCE, CLASSIC RACING & ROAD RACING



## DS-1 & DS-2 DYNAMIC RACING CONCEPT

DELANTE / ANTERIORI - SÓLO PARA USO EN CIRCUITO

- La alternativa elegida por numerosos campeones del mundo de Superbike, Supersport, Moto2 y Resistencia
- Compuesto sinterizado de alta tecnología disponible para sistemas de frenos de carreras y convencionales que se usan en competición
- DS-1: Si se prefiere una fuerte mordida inicial y un rendimiento gradual
- DS-2: Si se prefiere una mordida inicial suave y un rendimiento progresivo
- Ahora es posible combinar los dos compuestos: Disco de freno izquierdo DS-1 y disco de freno derecho DS-2. Esto ofrece una combinación de las diferentes características de rendimiento de los dos compuestos. En definitiva, un ajuste fino del rendimiento de frenado según las preferencias de frenado de cada piloto
- Tecnología NUCAP NRS que garantiza una adherencia mecánica e indestructible del compuesto

- La scelta di numerosi campioni mondiali di Superbike, Supersport, Moto2 ed Endurance
- Composto sinterizzato ad elevata tecnologia disponibile per impianti freni standard e da gara usati in competizioni
- DS-1: Se si preferisce una presa iniziale decisa e prestazioni lineari
- DS-2: Se si preferisce una presa iniziale regolare e prestazioni progressive
- Adesso è possibile combinare i due composti: Disco freno lato sinistro DS-1 e disco freno lato destro DS-2. In questo modo si ottiene una combinazione delle diverse caratteristiche prestazionali delle due mescole. In breve, una messa a punto delle prestazioni di frenata in base alle preferenze di frenata del singolo pilota
- La tecnologia NRS NUCAP garantisce un fissaggio meccanico ed indistruttibile del compost



## DC - DUAL CARBON

DELANTE / ANTERIORI - SÓLO PARA USO EN CIRCUITO

- La alternativa mejorada para pilotos de Superbike, Supersport y Superstock que corren en campeonatos nacionales así como para las tandas en circuitos
- Compuesto de carbono de alta tecnología desarrollado para sistemas de frenos de carreras y convencionales que se utilizan en motocicletas de carreras y deportivas
- Bajo coeficiente de transferencia de calor que protege el sistema de frenos y el líquido de frenos frente a las temperaturas extremas
- Mordida inicial suave y rendimiento en parada progresivo con modulación y sensibilidad excelentes en la maneta de freno
- Uso de la tecnología DEST para lograr el presentamiento del componente con el fin de evitar el desgaste y garantizar un rendimiento constante
- Tecnología NUCAP NRS que garantiza una adherencia mecánica e indestructible del compuesto

- La scelta più avanzata per piloti nei campionati nazionali Superbike, Supersport e Superstock e per piloti nei Track Day
- Composto al carbonio ad elevata tecnologia disponibile per impianti freni standard e da gara usato per moto da competizione e sportive
- Il tasso ridotto di trasferimento termico protegge l'impianto freni ed il liquido freni dalle temperature estreme
- Presa iniziale fluida, prestazioni di arresto gradual, con una sensazione e modulazione di frenata eccellenti
- La tecnologia DEST utilizzata per il pre-assestamento del composto elimina il fade ed assicura prestazioni costanti
- La tecnologia NRS NUCAP garantisce un fissaggio meccanico ed indistruttibile del composto

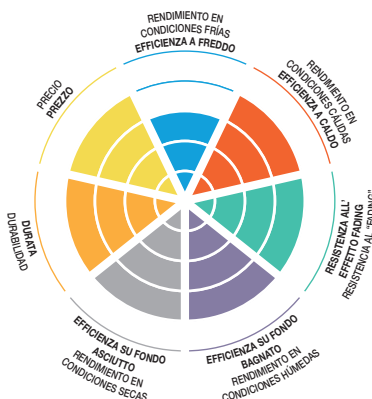

Diagramas de potencia de freno para comparar de forma individual los compuestos de RACING exclusivamente.

Diagrammi di prestazione dei freni da confrontare singolarmente con le sole mescole RACING.





RACING BRAKE PADS

**sbs**

GO AHEAD

## ENDURANCE, CLASSIC RACING & ROAD RACING / ROAD RACING & TRACKDAYS



RACING  
CLASSIC ROAD RACING

### DCC - DUAL CARBON

DELANTE / ANTERIORI - SÓLO PARA USO EN CIRCUITO



- // La elección para carreras clásicas en carretera gracias a los más de 25 años de experiencia en el Campeonato del Mundo e inspirada en nuestro material DC (Dual Carbon), ganador del mundial
- // Mordida inicial suave, ideal para la configuración clásica de horquilla delantera y las llantas. Prestaciones de frenado progresivas con mayor potencia y mejor tacto en la rueda delantera
- // Estabilidad térmica, adecuada para la configuración de 1 y 2 discos. Compatible con discos de freno de hierro fundido y acero inoxidable
- // Escasa conductividad térmica que reduce la carga térmica en las juntas, el líquido de frenos y las pinzas de freno
- // Uso de la tecnología DEST para lograr el preasentamiento del componente con el fin de evitar el desgaste y garantizar un rendimiento constante
- // Tecnología NUCAP NRS que garantiza una adherencia mecánica e indestructible del compuesto



- // La scelta per le competizioni su strada classiche deriva da oltre 25 anni di esperienza nei Campionati mondiali e si ispira al nostro materiale DC Dual Carbon vincente in questi campionati
- // Presa iniziale morbida, ideale per strutture di forcelle anteriori e pneumatici classici. Prestazioni graduali dei freni che offrono potenza superiore e controllo del frontale
- // Stabilità termica, adatta per schema dischi 1 e 2. Compatibile con dischi freni in acciaio inox e ghisa
- // La ridotta conduttività termica riduce il carico termico alle guarnizioni, al liquido freni ed ai componenti delle pinze
- // La tecnologia DEST utilizzata per il pre-assesamento del composto elimina il fade ed assicura prestazioni costanti
- // La tecnologia NRS NUCAP garantisce un fissaggio meccanico ed indistruttibile del composto



El carácter singular del compuesto DCC no permite compararlo con otros productos, ya que se trata de un compuesto formulado especialmente para coches clásicos de carreras.



Vista la natura unica del composto DCC, formulato specificamente per le corse di veicoli d'epoca, non è possibile paragonarlo ad altri prodotti.



### RST - SINTER

DELANTE / ANTERIORI



- // La elección perfecta y económica para las tandas en circuito y para motocicletas mixtas para circuito y carretera
- // Compuesto sinterizado disponible para los modernos sistemas de frenos convencionales de las motocicletas de competición y deportivas
- // Excelente para rotores/discos de freno de acero inoxidable o hierro fundido
- // Mordida inicial enérgica y rendimiento en parada gradual con buena sensación y control de frenado

A partir de 2020, la gama RST ha reemplazado a las pastillas RS 1:1 en cuanto a adaptación de aplicaciones. Sin embargo, ofrece mayor potencia de frenado e incluso mejor sensación y control de frenado. A los pilotos les basta saber que el tiempo de asentamiento es ligeramente mayor que en el caso de RS debido a la elevada durabilidad. Todas las pastillas RST se realizan con NRS. NRS (Nucap Retention System) es una tecnología de adherencia mecánica avanzada que se basa en una matriz de ganchos de acero construida a partir del material de acero de la placa posterior. Los ganchos NRS se adaptan al material de fricción y crean una unión mecánica anticorrosión e indestructible sin el uso de adhesivos. Principales ventajas de la tecnología NRS:

- // Ausencia de separación entre la placa posterior y el material de fricción
- // Ausencia de deformación de los bordes del material de fricción que proporciona sensación de firmeza
- // Ausencia de vibración entre el material de fricción y la placa posterior



- // La scelta ideale e conveniente per le giornate in pista e per le moto combinate da strada e pista
- // Composto sinterizzato disponibile per impianti freni standard moderni per moto sportive
- // Eccellente per rotori/dischi freni in acciaio inox o ghisa
- // Presa iniziale decisa, prestazioni di arresto lineari, con una buona sensazione e controllo di frenata

A partire dal 2020 la gamma RST ha sostituito le pastiglie RS 1:1, quando si parla di idoneità delle applicazioni. Tuttavia, con una maggiore potenza frenante e una sensazione di frenata e un controllo ancora migliori. I piloti devono solo essere consapevoli del fatto che il tempo di assestamento è leggermente aumentato rispetto al tipo RS a causa della maggiore durata. Tutte le pastiglie RST sono rinforzate con tecnologia NRS. NRS (Nucap Retention System) è un'avanzata tecnologia di incollaggio meccanico basata su una matrice di ganci d'acciaio sollevati dal materiale d'acciaio della piastra frenante. NRS si aggancia al materiale di attrito creando un legame meccanico indistruttibile e sicuro contro la corrosione senza l'uso di adesivi. Principali vantaggi della tecnologia NRS: Principali vantaggi della tecnologia NRS rispetto ai metodi tradizionali:

- // Nessuna separazione tra piastra posteriore e materiale di attrito
- // Nessuno spigolo sollevato nel materiale di attrito, con conseguente sensazione di una leva solida
- // Nessuna vibrazione tra materiale di attrito e piastra posteriore





## ENDURANCE, CLASSIC RACING & ROAD RACING



### RQ - CARBON TECH

POSTERIOR / POSTERIORI



- // Compuesto de carbono para el freno trasero con altas prestaciones de frenado
- // Sensación y control excelentes para gestionar la frenada en curvas
- // Parte de la nueva transición SBS Better Brakes



- // Composto al carbonio per freni posteriori con elevate prestazioni di frenata
- // Sensazione e controllo di frenata eccellenti nell'uso del freno posteriore in ingresso ed in uscita dalle curve
- // Parte della nuova transizione SBS Better Brakes



### LS - SINTER

POSTERIOR / POSTERIORI



- // Compuesto sinterizado para el freno trasero con prestaciones de frenado de nivel medio y larga duración de la pastilla
- // Recomendado para pilotos que utilizan el freno trasero de manera esporádica o ligeramente al entrar en curvas
- // Parte de la nueva transición SBS Better Brakes



- // Composto sinterizzato per freni posteriori con prestazioni di frenata media e lunga durata delle pastiglie
- // Consigliato per motociclisti che usano il freno posteriore occasionalmente e solo leggermente in ingresso alle curve
- // Parte della nuova transizione SBS Better Brakes



# LICENSE TO ACTION

## #OFFROADBIKE



**JEREMY SEEWER**  
YAMAHA MX GP FACTORY TEAM  
2022 SILVER & 2023 BRONZE  
MOTOCROSS GP CHAMPIONSHIP



Disfrutar de la libertad en el desierto. Conquistar colinas y montañas. Recorrer pistas de tierra a gran velocidad para llegar a lo más alto en las competiciones.

Si su pasión es el off-road, SBS ofrece el compuesto de freno ideal para entornos agresivos con gran cantidad de arena, polvo, barro y agua. En motocicleta, ATV o UTV.

Puede elegir pastillas de carreras para competir a todos los niveles o bien pastillas alternativas para salidas de ocio. Nuestra gama cubre todas las marcas y modelos todoterreno, así como las aplicaciones delantera y trasera.

La mayoría de las pastillas de freno tienen la homologación ECE R90.

Puede elegir entre:

// UPGRADE & RACING – RSI / PSI

// CLUB, TRAILS & LEISURE – SI / CS / ATS

Para acertar con las pastillas de su motocicleta, siga nuestras recomendaciones.



Godersi la libertà del deserto. Conquistare rocce e montagne. Correre su strade sterrate per arrivare sul podio.

Se la guida off road è la tua passione, SBS ti offre il composto ideale per i freni per ambienti aggressivi con sabbia, polvere, fango e acqua. Su moto, ATV o UTV.

Scegli tra le nostre pastiglie per competizioni a tutti i livelli o le alternative quando fai fuoristrada semplicemente per divertirti. La nostra gamma spazia tra tutte le marche ed i modelli off road, ovviamente per applicazioni sia anteriori sia posteriori.

La maggior parte delle pastiglie dei freni sono omologate ECE R90.

Scegli tra:

// UPGRADE & RACING – RSI / PSI

// CLUB, TRAILS & LEISURE – SI / CS / ATS

Segui i nostri consigli sulle pastiglie ideali per la tua moto.

**sbs**<sup>®</sup>  
GO AHEAD





OFF ROAD & ATV BRAKE PADS

sbs

GO AHEAD

## UPGRADE & RACING / CLUB, TRAILS & LEISURE



### RSI - SINTER

DELANTE / ANTERIORI • POSTERIOR / POSTERIORI



- // Alternativa con mejora de prestaciones elegida por equipos y pilotos del Campeonato del Mundo de MX GP y MX2
- // Compuesto sinterizado formulado para ofrecer alta estabilidad térmica, potencia y resultados predecibles sin desgaste
- // Compatible con discos de frenos estándar originales y discos para frenos de carreras con diseño especial



- // La scelta dei piloti e dei team MX GP ed MX2 nel Campionato Mondiale MX GP
- // Composto sinterizzato formulato per un'elevata stabilità termica, prestazioni potenti e prevedibili senza fade
- // Compatibile con dischi freni standard OE e con dischi da competizione speciali



Diagramas de potencia de freno para comparar de forma individual los compuestos de OFF ROAD exclusivamente.



### SI - SINTER

DELANTE / ANTERIORI • POSTERIOR / POSTERIORI



- // La alternativa moderna para lugares con mucho barro, humedad o arena
- // Compuesto sinterizado formulado para ofrecer largos periodos de vida útil, alto rendimiento y fácil modulación
- // Rendimiento estable de primer nivel desarrollado en carrera en condiciones rigurosas
- // Parte de la nueva transición SBS Better Brakes



- // La scelta ottimale su fango, bagnato o sabbia
- // Composto sinterizzato formulato per manutenzione ridotta, prestazioni elevate e facile modulazione
- // Prestazioni fluide leader nella categoria, sviluppate nelle competizioni in condizioni difficili
- // Parte della nuova transizione SBS Better Brakes



Diagrammi di prestazione dei freni da confrontare singolarmente con le sole mescole OFF ROAD.





OFF ROAD & ATV BRAKE PADS

sbs

GO AHEAD

## UPGRADE & RACING / CLUB, TRAILS & LEISURE



### PSI - EVO SINTER

DELANTE / ANTERIORI • POSTERIOR / POSTERIORI



- // Compuesto de recambio original y mejorado para ATV y UTVs
- // Compuesto EVO con sinterizado conductivo de vanguardia, formulado para lograr una mordida inicial enérgica con sensación inmediata de frenado, fácil modulación y altas prestaciones en las paradas
- // Resistente al desgaste con rendimiento constante y fiable en condiciones de conducción extremas y durante toda la vida útil de la pastilla de freno
- // Tecnología NRS que garantiza una adherencia mecánica e indestructible del compuesto
- // Disponibilidad de la gama completa en el primer trimestre de 2021



- // Composto per migliorare e sostituire il prodotto OE per ATV e UTV
- // Avanzato composto sinterizzato con riscaldamento diretto a resistenza/EVO formulato per una presa iniziale decisa con una sensazione di frenata istantanea, modulazione facile e arresto efficace
- // Prestazioni affidabili, costanti e senza fade in condizioni di guida estreme e per tutta la durata utile delle pastiglie dei freni
- // La tecnologia NRS garantisce un fissaggio meccanico ed indistruttibile del composto
- // Disponibilità dell'intera gamma completata nel 1° trimestre 2021



Diagramas de potencia de freno para comparar de forma individual los compuestos de OFF ROAD exclusivamente.

Diagrammi di prestazione dei freni da confrontare singolarmente con le sole mescole OFF ROAD.



### ATS - SINTER

DELANTE / ANTERIORI • POSTERIOR / POSTERIORI



- // Compuesto de recambio original para combinar con discos de freno de acero normales
- // Compuesto sinterizado compatible con modelos originales de discos de freno de acero normales, como los que se emplean en los modelos ATV Arctic Cat y Polaris ATV
- // Parte de la nueva transición SBS Better Brakes



- // Composto per sostituire il prodotto OE in abbinamento con dischi freni in acciaio semplice
- // Composto sinterizzato compatibile con dischi freni in acciaio semplice standard OE come quelli utilizzati nei modelli ATV Arctic Cat e Polaris meno recenti
- // Parte della nuova transizione SBS Better Brakes



### CS - CARBON

DELANTE / ANTERIORI • POSTERIOR / POSTERIORI



- // Alternativa de recambio económica para competición y aficionados al motocross
- // Compuesto de carbono con funcionamiento suave, silencioso y sin agarrotamiento
- // Tecnología NUCAP NRS que garantiza una adherencia mecánica e indestructible del compuesto
- // Parte de la nueva transición SBS Better Brakes



- // Ricambi convenienti per motocross amatoriale e agonistico
- // Composto al carbonio che offre prestazioni fluide, silenziose e senza scatti
- // La tecnologia NRS NUCAP garantisce un fissaggio meccanico ed indistruttibile del composto
- // Parte della nuova transizione SBS Better Brakes





BRAKE SHOES

sbs

GO AHEAD

## ZAPATAS DE FRENO CON MUELLES

## MOLLE RICHIAMO GANASCE FRENI



Guarnición de freno sin amianto que ofrece un resultado y una durabilidad superiores en cualquier clima. Aleación de aluminio de alta calidad con resistencia superior. Superficie con tratamiento anticorrosión. Muelles realizados con alambre de acero de alta calidad conforme con las especificaciones DIN 17223 para una flexibilidad máxima.



Rivestimento freno privo di amianto per prestazioni eccellenti e durata in tutte le condizioni climatiche. Lega di qualità superiore per maggiore resistenza. Superficie trattata contro la corrosione. Molle di richiamo ganasce freno con filo di acciaio di alta qualità, secondo le specifiche DIN 17223 per ottenere la massima flessibilità.





**BRAKE PINS**

**sbs**

GO AHEAD

## TORNILLOS DE FRENO INOXIDABLES

## PERNI IN ACCIAIO INOSSIDABILE

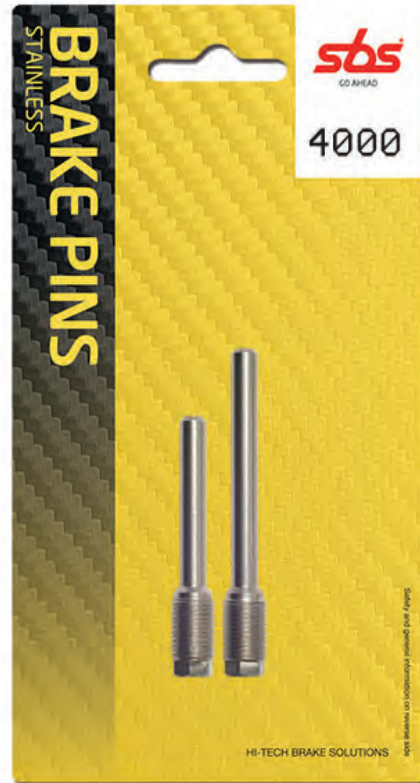

La serie de tornillos de freno inoxidable de SBS cubre las gamas de motocicletas MX y Enduro más comunes que aparecieron en la década de 1990 y que siguen existiendo en la actualidad.

La gama incluye 5 juegos completos de tornillos delanteros y traseros, pero también hay disponibles paquetes individuales (solo con tornillos delanteros o solo con traseros) específicos para cada modelo. Los tornillos de las zapatas de los frenos presentan grietas de desgaste después de un tiempo, por lo que se recomienda sustituirlos de forma periódica para evitar problemas de fricción estática y escaso rendimiento.

- // Realizados en acero inoxidable 304 de alta calidad
- // Cabeza hexagonal de 8 mm para un cambio rápido y fácil de la zapata del freno (excl. ref 4003)
- // Anticorrosión
- // Acoplamiento suave entre tornillos y zapatas de freno



La gamma di perni delle pinze dei freni in acciaio inossidabile SBS comprende prodotti per le moto MX ed Enduro più diffuse dall'inizio del 1990 ad oggi.

La gamma comprende 5 set completi, per anteriore e posteriore, ma sono disponibili anche confezioni singole con solo l'anteriore o il posteriore del relativo modello. Dopo un certo periodo di tempo, sui perni delle pastiglie dei freni si creano dei solchi dovuti all'usura, si consiglia pertanto di sostituirli con regolarità per prevenirne il distacco o le scarse prestazioni.

- // In acciaio inossidabile 304 di alta qualità
- // Testa esagonale da 8 mm per sostituzione delle pastiglie freni semplice e veloce (escluso il part. rif. 4003)
- // Inossidabile
- // Elevata scorrevolezza tra perno e pastiglie freni





BRAKE SYSTEM BLEEDER & ANTI-NOISE SHIMS

sbs

GO AHEAD

## ACCESORIOS

## ACCESSORI



### PURGADOR DE FRENOS

Purgador del sistema de frenos de la motocicleta que permite cambiar el líquido de freno de forma rápida, limpia y segura. Se requiere una presión del aire mínima de 6 bar. El purgador de frenos está realizado con los materiales mejores y más resistentes al líquido de freno: el líquido, que es muy corrosivo, se mantiene en un circuito cerrado. Una válvula de seguridad especial y "antivuelco" impide la pulverización del líquido cuando el recipiente está lleno.

- // Válvula "antivuelco" incorporada
- // Llave giratoria
- // Conducto adicional de doble boquilla incluido
- // Manual en 12 idiomas

N.º de pieza 5809839100  
Unidades de caucho EPDM  
N.º art. 5809939100 (10 uds.)



### SFIATO FRENO

Sfiato dell'impianto frenante delle moto che permette una sostituzione rapida, sicura e pulita del liquido freni. È necessario avere a disposizione una pressione minima di 6 bar. Lo sfiato è formato dai migliori materiali, più resistenti al liquido freni, permettendo così di gestire il liquido freni altamente corrosivo all'interno di un circuito chiuso. Una speciale valvola di sicurezza di non ritorno evita che il flusso si atomizzi quando il contenitore è pieno.

- // Valvola di non ritorno incorporata
- // Raccordo per tubazione girevole
- // Tubazione aggiuntiva con 2 ingrassatori compresa
- // Manuale in 12 lingue

Numero di part. 5809839100  
Unità in gomma EPDM  
Numero art. 5809939100 (10 pezzi)

28



### CUÑAS DE PASTILLAS DE FRENO

- // Resistente a vibraciones/ruídos
- // Resistente a la transferencia del calor
- // Ideal para proteger el pistón
- // Mejor sensación de frenado
- // No utilizar en carreras

N.º de pieza 9500 (uds.)



### SPESSORI PER PASTIGLIE FRENI

- // Resistenti al rumore/alle vibrazioni
- // Resistenti al passaggio di temperatura
- // Protezione per i pistoni
- // Miglior sensazione di frenata
- // Da non utilizzare per le corse

Numero part. 9500 (pezzi)





**MERCHANDISE**

**sbs**<sup>®</sup>

GO AHEAD

## MERCHANDISE

Request the full merchandise catalogue from SBS customer service.



**T-SHIRT GO AHEAD**

Art. no.	Size
6819915100	S
6829915100	M
6839915100	L
6849915100	XL



**JACKET - DOWN&FEATHER**

Art. no.	Size
6829841100	M
6839841100	L
6849841100	XL



**BEANIE – 10 pcs**

Art. no.	Size
6829918100	M
6839918100	L



**FLUID CAP**  
– 12 pcs

Art. no.
6809800100



**GLOVES**

Art. no.	Size
6829812100	M
6839812100	L
6849812100	XL



**EARPLUGS**

Art. no.
6809815100

**PENS – 50 pcs**

Art. no.
6809804100



**CAP**  
**BASEBALL MODEL**

Art. no.
6801001100



**CAP**  
**TRUCKER MODEL**

Art. no.
6801002100



**Sticker Racing Supertack**

Art. no.
6809704100



**Sticker Racing Supertack**

Art. no.
6809703100



**Sticker**

Art. no.
6809702100 – ø34 mm
6809701100 – ø80 mm

# RESOURCES

## SBS ROAD RACING BRAKE BOOK – ONLINE FLIPPING – SCAN QR CODE

Paper Booklet  
56 pages  
Art. no.  
6809725100



- ▶ Tech info
- ▶ Tips & tricks
- ▶ Race applications

## SBS BRAKE PARTS FLYER

## SBS BETTER BRAKES FLYER



Explore the full resources list and download from [sbsbrakes.com](https://sbsbrakes.com)



CHAMPIONSHIP POSTERS



WORLD MOTO2 JR GR  
CHAMPION 2023



WORLD WOMEN'S MOTOCROSS GP  
CHAMPION 2023



WORLD SUPERSPORT 300  
CHAMPION 2023



ISLE OF MAN TT  
WINNER 2023

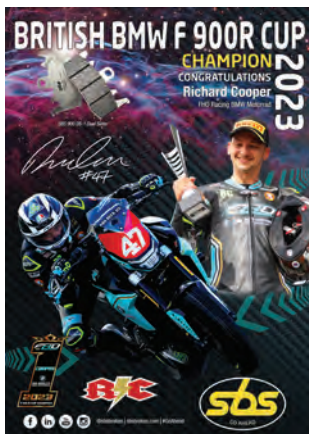

BRITISH BMW F 900R CUP  
CHAMPION 2023



BRITISH SUPERBIKE  
CHAMPION 2023



EUROPEAN YAMAHA R3 CUP  
CHAMPION 2023



FIM ASIA SUPERBIKE  
CHAMPION 2023



FRENCH SUPERBIKE  
CHAMPION 2023



INT DUTCH SUPERBIKE  
CHAMPION 2023



ISLE OF MAN TT  
WINNER 2023



MACAU GRAND PRIX  
WINNER 2023

Explore all the digital assets to promote SBS by in SBS Media Library [media.sbs.dk/MediaLibrary/welcome](https://media.sbs.dk/MediaLibrary/welcome)







MOTORCYCLE AND SCOOTER BRAKE SYSTEM COMPONENTS



GO AHEAD

## WIDGET DE CONSULTA DE MODELOS



UTILICE EL WIDGET DE CONSULTA DE MODELOS QUE SE ENCUENTRA EN WWW.SBSBRAKES.COM

- Conéctese y encuentre los mejores productos de frenado para su moto.
- // Vaya a [www.sbsbrakes.com](http://www.sbsbrakes.com)
- // Seleccione el modelo de moto concreto, el año y la cilindrada (en orden aleatorio)
- // Aparecerá una lista con las pastillas de freno, los discos de freno y los kits de embrague que puede utilizar su moto (recomendados y optativos)

“Go Ahead”

## WIDGET DI RICERCA MODELLO



UTILIZZA IL WIDGET DI RICERCA MODELLO SU WWW.SBSBRAKES.COM

- Vai online e trova i migliori prodotti per freni per la tua moto.
- // Vai su [www.sbsbrakes.com](http://www.sbsbrakes.com)
- // Seleziona il tuo modello di moto specifico, l'anno e la cilindrata (in ordine casuale)
- // Troverai l'elenco delle pastiglie e dei dischi dei freni e i kit frizione adatti alla tua moto (consigliati e opzionali)

“Go Ahead”

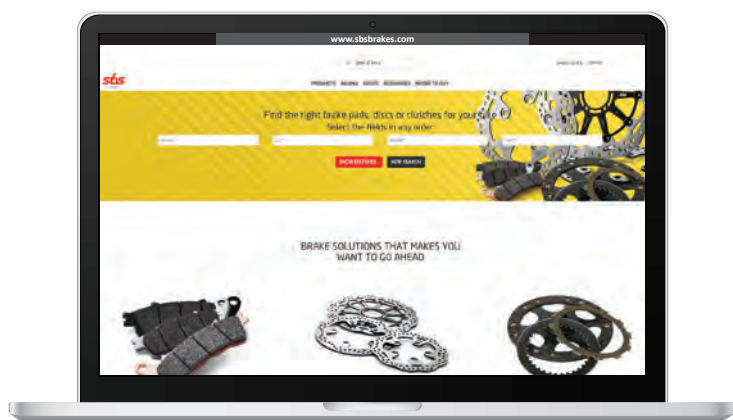

# ANY MAKE. ANY MODEL. ANY YEAR.

Go online and find exactly what you need.

Use the **Model Look-up widget** at [www.sbsbrakes.com](http://www.sbsbrakes.com)

## WIDGET DEL SELECTOR DE COMPUESTO



UTILICE EL WIDGET DEL SELECTOR DE COMPUESTO QUE SE ENCUENTRA EN WWW.SBSBRAKES.COM

- Conéctese y encuentre el compuesto de freno ideal para su tipo de motocicleta y sus necesidades.
- // Vaya a [www.sbsbrakes.com](http://www.sbsbrakes.com)
- // Seleccione el tipo de motocicleta, las condiciones de uso y el tamaño concretos
- // Se indicará el tipo de compuesto adecuado al tipo de motocicleta y a sus necesidades para la parte delantera y la parte trasera

“Go Ahead”

## WIDGET DI SELEZIONE MESCOLO



UTILIZZA IL SELETTORE MESCOLO SU WWW.SBSBRAKES.COM

- Vai online e trova la mescola per freni ideale per il tuo tipo di moto e per le tue esigenze.
- // Vai su [www.sbsbrakes.com](http://www.sbsbrakes.com)
- // Selezionare il tipo di moto, le condizioni di utilizzo e le dimensioni specifiche
- // Verrà indicato il tipo di mescola giusta che corrisponde al tuo tipo di moto e di cui hai bisogno per l'anteriore e il posteriore

“Go Ahead”

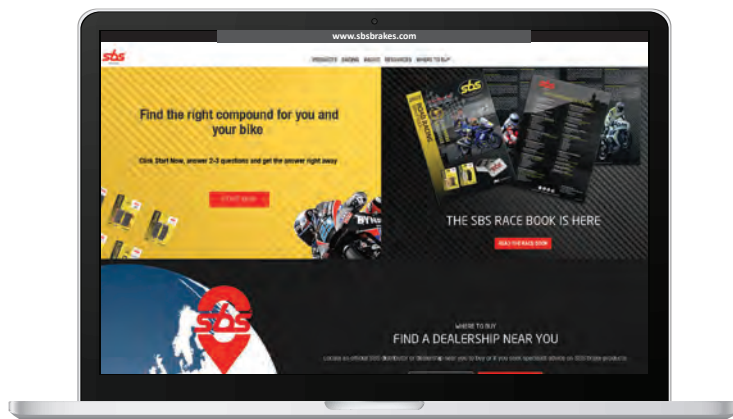

# GET THE BRAKE FEEL YOU WANT!

Go online and find the right compound for you and your bike.

Use the **Compound Selector widget** at [www.sbsbrakes.com](http://www.sbsbrakes.com)





**Emil Senf Jakobsen**

Category Manager SBS

**sbs**<sup>®</sup>

GO AHEAD

**I KNOW  
WHAT YOU  
WANT!**

**MOTORCYCLE  
SCOOTER  
DIRT BIKE  
ATV/UTV**



@sbsbrakes | sbsbrakes.com | #GoAhead

HI-TECH BRAKE SOLUTIONS  
MADE IN EUROPE

**RECOMMENDED**1xx - 2xx = Scooter Pads  
5xx - 9xx = Street, Off Road & Racing Pads  
2xxx = Brake Shoes

ADIVA					
AD	250	06 - 22	157 MS	157 MS	
ADLY					
	25 Silver Fox	00 - 05	111 HF	2028	
	50 Cat	01 - 08	111 HF		
	50 Cosy	01 - 08	111 HF		
	50 Fox	00 - 09	111 HF	2028	
	50 Fox Plus	01 - 09	111 HF		
	50 Jet	96 - 99	111 HF	2028	
	50 Panther	01 - 09	102 HF		
	50 Pista, Pista Twin Light	96 - 99	111 HF	2028	
	50 Silver Fox	00 - 05	111 HF	2028	
	50 Silver Fox	06 - 09	102 HF	2028	
	50 Super Sonic	00 - 05	102 HF*		
	50 Thunderbike	97 - 09	102 HF		
RS	50 Super Sonic	06 - 08	102 HF	102 HF	
RT	50 Road Tracer	02 - 06	111 HF		
	70 Fox Plus	01 - 05	111 HF		
	70 Pista, Pista Twin Light	01 - 05	111 HF		
	80 Cosy	01 - 06	111 HF		
RT	90 Road Tracer	02 - 06	111 HF		
	100 Cat	01 - 10	111 HF		
	100 Jet	96 - 99	111 HF	2028	
	100 Panther	01 - 06	102 HF		
	100 Silver Fox	01 - 05	111 HF		
	100 Silver Fox	06 - 06	102 HF	2028	
	100 Super Sonic	01 - 05	102 HF*		
	100 Thunderbike	01 - 04	102 HF*	102 HF	
RT	100 Road Tracer	02 - 06	111 HF		
	125 Cat	01 - 04	111 CT		
	125 Super Sonic	01 - 05	102 CT*		
	125 Thunderbike	01 - 04	102 CT*	102 CT	
	150 ATV	05 - 07	544 SI*	544 SI	
	150 Interceptor	05 - 07	544 SI*	544 SI	
	300 ATV	05 - 11	544 SI*	544 SI	
	300 Cross X Over	07 - 11	810 SI*		
	300 Cross X Road	07 - 11	810 SI*		
ATV	300 Sport	07 - 13	810 SI*	848 SI	
	320 S	07 - 13	810 SI*		
	320 U	07 - 13	810 SI*		
AEON					
	50 Aero	06 - 06	101 HF		
	50 Regal	06 - 06	101 HF		
	50 Torch	06 - 09	101 HF		
	90 Regal	06 - 06	101 HF		
	100 Pulsar	06 - 06	101 HF		
	100 Revo 2	04 - 06	2043*	544 SI	
	110 Aero	06 - 06	101 HF		
	110 Pulsar	06 - 06	101 HF		
	125 Co-In	14 - 14	101 CT		
	125 Elite	13 - 14	163 CT	101 CT	
	125 Overland	02 - 11		638 SI	
	125 Oz	14 - 14	119 CT		
	125 Pulsar	06 - 06	544 HF		
	125 Urban	11 - 13	163 CT	101 CT	
	125 Urban	14 - 14	119 CT		
	150 Pulsar	06 - 06	101 CT		
	180 Overland	02 - 11		638 SI	
	180 Roadster	02 - 09		638 SI	
	250 Elite	11 - 14	163 CT	101 CT	
	350 Urban	11 - 13	163 CT	101 CT	
	400 Elite	14 - 15	215 MS	119 MS	
AJP					
PR3	125 Enduro	08 - 12	774 HF	802 HF	
PR3	125 Enduro	13 - 15	859 HF		
PR3	125 Enduro Pro	13 - 15	859 HF		
PR3	125 Extreme	13 - 15	859 HF		
PR3	125 Supermotard	08 - 12	774 HF	802 HF	
PR3	125 Supermoto	13 - 15	859 HF		
PR4	125 Enduro	04 - 12	817 HF	802 HF	

**RECOMMENDED**1xx - 2xx = Scooter Pads  
5xx - 9xx = Street, Off Road & Racing Pads  
2xxx = Brake Shoes

AJP					
PR4	125 Enduro	13 - 15	859 HF		
PR4	125 Enduro Pro	13 - 15	859 HF		
PR4	125 Supermotard	04 - 09	817 HF	802 HF	
PR4	125 Supermoto	13 - 15	859 HF		
PR4	125 Trail	13 - 15	859 HF		
MX	200	09 - 11	774 HF	559 HF	
PR3	200 Enduro	08 - 12	774 HF	802 HF	
PR3	200 Supermotard	08 - 12	774 HF	802 HF	
PR4	200 Enduro	04 - 04	817 HF	802 HF	
PR4	200 Supermotard	04 - 04	817 HF	802 HF	
PR3	240 MX	13 - 15	859 SI		
PR5	250 Enduro	09 - 09	694 SI	604 SI	
PR5	250 Enduro	10 - 15	859 HF		
PR5	250 Extreme	12 - 15	859 HF		
PR5	250 Supermotard	09 - 09	694 SI	604 SI	
PR5	250 Supermoto	10 - 15	859 HF		
PR7	650 Adventure	17 - 17	859 HF	604 HF	
ALFER					
MC	80	87 - 87	519 HF	559 HF	
MC	125	87 - 87	519 HF		
MC	125	88 - 88	601 HF	519 HF	
VRE	125 4-stroke	00 - 00	671 SI	675 SI	
GR	250 Enduro	85 - 85	519 HF		
GR	250 Enduro	88 - 88	601 HF	519 HF	
MC	250	85 - 85	519 HF		
MC	250	87 - 87	519 HF	519 HF	
MC	250	88 - 88	601 HF	519 HF	
VR	250 Cross	99 - 99	671 RSI	675 RSI	
VR	250 Enduro	99 - 99	671 SI	675 SI	
VR	250 No Limit	99 - 99	671 RSI	675 RSI	
VR	250 Supermotard	99 - 99	671 RSI	675 RSI	
GR	300	85 - 85	519 HF		
GR	300 Enduro	88 - 88	601 HF	519 HF	
APRILIA					
	50 Amico	90 - 91	2012	2012	
	50 Amico, Scooter	92 - 92	123 HF	2050	
	50 Amico, GL, GLE	93 - 98	123 HF	2012	
	50 Area 51	99 - 02	143 HF	143 HF	
	50 Business	97 - 98	123 HF		
	50 Classic	96 - 99	123 HF		
	50 Club	97 - 99	123 HF		
	50 Compay	09 - 13	143 HF	2201	
	50 Gulliver	96 - 00	123 HF	2012	
	50 Habana/Custom	99 - 02	143 HF	2201	
	50 McGulliver	00 - 00	123 HF		
	50 Mini RX	04 - 04	803 RSI		
	50 Mojito Retro	99 - 03	143 HF	2201	
	50 Mojito, Mojito Custom	99 - 03	143 HF	2201	
	50 Mojito, Mojito Custom	04 - 12	143 HF		
	50 Rally	95 - 01	123 HF	2012	
	50 Red Rose	88 - 89	132 HF		
	50 Red Rose	90 - 94	109 HF		
	50 Red Rose Classic	92 - 94	607 HF		
	50 Scarabeo 4T	04 - 09	153 HF		
	50 Scarabeo Ditech	02 - 06	123 HF	152 HF	
	50 Scarabeo Street	00 - 06	123 HF	2012	
	50 Scarabeo, 2nd series	94 - 99	123 HF	2012	
	50 Sonic, GP	99 - 09	123 HF	2012	
	50 Sport City One	08 - 12	177 HF		
	50 Tuareg	85 - 85	519 HF		
	50 Tuareg	86 - 96	607 HF	574 HF	
	50 Tuareg Rally	90 - 96	607 HF	574 HF	
	50 Tuono	04 - 07	168 HF	138 HF	
	50 Younger	97 - 97	123 HF		
AC	50 Rally	95 - 02	123 HF	2012	
AF1	50 AE	86 - 96	109 HF	106 HF	
AF1	50 Europa, Futura	90 - 92	109 HF	106 HF	
ET	50	85 - 90	138 HF		
LC	50 Rally	96 - 01	123 HF	123 HF	
LX	50 Amico, Sport	92 - 97	114 HF	2012	

\* = 2 sets required / 2 jeux pour l'Avant.

Full compound selection, see under "Brake pad 1:1 Drawings" / Sélection complète de composants, voir "1:1 Schémas Plaquettes de frein".





**RECOMMENDED**

1xx - 2xx = Scooter Pads  
5xx - 9xx = Street, Off Road & Racing Pads  
2xxx = Brake Shoes



APRILIA					
MX	50	03 - 10	120 HF	106 HF	
RS	50	93 - 95	138 HF	138 HF	
RS	50	96 - 99	138 HF	106 HF	
RS	50	06 - 11	157 HF	105 HF	
RS	50 , Replica	00 - 05	120 HF	106 HF	
RS-4	50	12 - 19	189 MS	101 HF	
RS-4	50 Replica	16 - 17	189 MS	101 HF	
RX	50	90 - 05	120 HF	106 HF	
RX	50	06 - 14	186 HF	105 HF	
RX	50 Racing	04 - 06	120 HF	106 HF	
SR	50 Ditech	01 - 06	123 HF	152 HF	
SR	50 Europa	93 - 94	114 HF	2012	
SR	50 Motard	18 - 22	237 HF		
SR	50 Racing	00 - 04	123 HF	152 HF	
SR	50 Replica	94 - 96	117 HF	2012	
SR	50 Replica (Liquid Cooled)	96 - 96	123 HF	2012	
SR	50 Stealth, Racing	97 - 00	123 HF	123 HF	
SR	50 Street	05 - 12	123 HF	152 HF	
SR	50 Urban Kid	93 - 07	114 HF	2012	
SR	50 Viper	93 - 94	114 HF	2012	
SR	50 WWW, Netscaper	97 - 99	149 HF	2012	
SX	50	06 - 13	186 HF		
SX	50 Ltd.	07 - 15	197 CT	101 CT	
SXR	50	21 - 23	237 HF		
	100 Scarabeo	00 - 06	153 HF		
	100 Scarabeo 4T	03 - 11	153 HF		
	100 Scarabeo Net	10 - 14	153 HF		
	125 Atlantic	03 - 14	159 CT	152 CT	
	125 Classic	96 - 03	652 HF	519 HF	
	125 Habana/Custom	00 - 02	153 CT	2205	
	125 Leonardo	96 - 96	123 CT	106 CT	
	125 Leonardo	97 - 98	149 CT	143 CT	
	125 Leonardo	99 - 06	153 CT	153 CT	
	125 Leonardo (Grimeca cal.)	99 - 06	108 CT	153 CT	
	125 Mojito, Mojito Custom	02 - 12	153 CT	2205	
	125 Pegaso	90 - 91	652 HF	692 HF	
	125 Pegaso	92 - 99	689 HF	651 HF	
	125 Red Rose	89 - 89	588 HF	519 HF	
	125 Red Rose	90 - 97	652 HF	519 HF	
	125 Scarabeo, Scarabeo GT	99 - 03	108 CT	152 CT	
	125 Scarabeo, Scarabeo GT	04 - 10	159 CT	152 CT	
	125 Sport Pro.	92 - 92	601 HF	519 HF	
	125 Sportcity (Grimeca cal.)	04 - 12	108 CT	152 CT	
	125 Sportcity (Hengtong cal.)	04 - 12	177 CT	152 CT	
	125 Strada	85 - 85	574 HF		
	125 Tuareg	86 - 86	588 HF		
	125 Tuareg	87 - 92	605 HF	519 HF	
	125 Tuareg AS	86 - 86	605 HF	519 HF	
	125 Tuareg Rally	86 - 92	652 HF	651 HF	
	125 Tuareg Wind	88 - 88	607 HF	574 HF	
	125 Tuareg Wind	90 - 94	652 HF	692 HF	
	125 Tuono	04 - 07	601 HF	519 HF	
	125 Tuono ABS	17 - 19	821 HS	544 HF	
AF1	125	87 - 87	608 HF	519 HF	
AF1	125	88 - 88	608 HF	574 HF	
AF1	125 Europa, Futura	90 - 92	601 HF	519 HF	
AF1	125 Replica, Sintesi	89 - 91	601 HF	519 HF	
ETX	125	84 - 86	588 HF		
ETX	125	92 - 99	120 CT		
ETX	125 PV	86 - 02	606 HF		
ETX	125 Tuareg	86 - 87	588 HF	519 HF	
MX	125	04 - 07	671 HF	651 HF	
MX	125 Cross	85 - 85	588 HF		
MX	125 Supermoto	07 - 07	671 HF	651 HF	
RS	125	99 - 05	601 HF	824 HF	
RS	125	06 - 12	844 HF	747 HF	
RS	125	17 - 19	821 HS	544 HF	
RS	125 Extrema	93 - 98	601 HF	824 HF	
RS	125 GP	17 - 19	821 HS	544 HF	
RS	125 Pista	05 - 07	601 HF	824 HF	
RS-4	125 (AJP cal.)	11 - 19	821 HS	585 HF	
RS-4	125 (J.Juan cal.)	11 - 19	566 HS	544 HF	



**RECOMMENDED**

1xx - 2xx = Scooter Pads  
5xx - 9xx = Street, Off Road & Racing Pads  
2xxx = Brake Shoes



APRILIA					
RS-4	125 Replica, ABS	16 - 19	821 HS	544 HF	
RX	125	86 - 89	606 HF		
RX	125	90 - 90	641 HF	586 HF	
RX	125	91 - 91	641 HF	692 HF	
RX	125	92 - 92	641 HF	684 HF	
RX	125	97 - 99	671 HF	692 HF	
RX	125 Enduro	08 - 12	671 HF	544 HF	
RX	125 Supermotard	08 - 12	671 HF	544 HF	
SR	125	99 - 03	153 CT	2205	
SR	125 GT	21 - 23	228 CT	187 CT	
SR	125 Max	12 - 17	177 CT	177 CT	
SR	125 Sport City One	12 - 12	177 CT		
STX	125	84 - 84	605 HF		
SX	125	08 - 13	671 HF	651 HF	
SX	125	18 - 22	611 HF	544 HF	
TX	125	86 - 86	606 HF		
	150 Leonardo	97 - 98	149 CT	143 CT	
	150 Leonardo	99 - 05	153 CT	153 CT	
	150 Leonardo (Grimeca cal.)	99 - 05	108 CT	153 CT	
	150 Scarabeo	99 - 04	108 CT	152 CT	
	150 Scarabeo, Scarabeo GT	04 - 05	159 CT	152 CT	
SR	150	00 - 03	153 CT	2205	
SXR	160	21 - 23	237 HF		
	200 Atlantic	03 - 06	159 CT	152 CT	
	200 Climber	93 - 95	519 RSI	519 RSI	
	200 Scarabeo	07 - 09	159 CT	152 CT	
	200 Scarabeo Class	10 - 12	159 CT	152 CT	
	200 Scarabeo ie	12 - 12	159 CT	152 CT	
	200 Scarabeo, Scarabeo GT	02 - 03	108 CT	152 CT	
	200 Sportcity	04 - 08	108 CT	152 CT	
SR	200 GT	21 - 23	228 CT	187 CT	
	240 Climber	89 - 90	607 HF	574 HF	
TX	240	86 - 88	559 RSI		
	250 Atlantic	07 - 12	159 MS	152 MS	
	250 Leonardo	99 - 05	153 MS	152 MS	
	250 Leonardo (Grimeca cal.)	99 - 05	108 MS	152 MS	
	250 Scarabeo, Scarabeo ie	06 - 11	159 MS	152 MS	
	250 Sportcity	06 - 08	108 MS*	152 MS	
	250 Tuareg Rally	86 - 86	588 HF	519 HF	
AF1	250 Replica	90 - 90	601 HF	506 HF	
MX	250 Cross	85 - 85	519 SI		
RS	250	95 - 96	566 HF	519 HF	
RS	250	97 - 02	706 HF*	519 HF	
RS	250 Pista	04 - 04	706 HF*	519 HF	
RX	250	86 - 86	519 HF		
	275 Climber	89 - 90	607 HF	574 HF	
	280 R, Climber	92 - 92	559 RSI	559 RSI	
	300 Leonardo (Grimeca cal.)	05 - 06	108 MS	153 MS	
	300 Scarabeo Special	10 - 11	159 MS	152 MS	
SR	300 Max	12 - 19	177 MS	177 MS	
TX	311	86 - 86	559 RSI		
TX	312 M	88 - 88	559 RSI	559 RSI	
TXR	312 M	88 - 88	559 RSI	559 RSI	
	350 Tuareg	86 - 86	588 HF	519 HF	
	350 Tuareg	88 - 89	641 HF	519 HF	
	350 Tuareg Wind	87 - 87	588 HF	519 HF	
	350 Tuareg Wind	88 - 88	594 HF	519 HF	
	350 Tuareg Wind	90 - 94	641 HF	586 HF	
ETX	350	85 - 86	588 HF	519 HF	
ETX	350	87 - 92	605 HF	519 SI	
	400 Scarabeo ie	07 - 08	108 MS*	152 MS	
MXV	450	09 - 13	694 RSI	790 RSI	
RXV	450	06 - 13	694 SI	790 SI	
SXV	450	06 - 13	842 RSI	790 RSI	
SXV	450 Van den Bosch Rep.	08 - 10	695 RST	790 RSI	
RS	457	24 - 24	877 HS	675 LS	
	500 Atlantic Left	02 - 05	108 MS	152 MS	
	500 Atlantic Right	02 - 05	179 MS		
	500 Atlantic Sprint	06 - 10	159 MS	152 MS	
	500 Scarabeo	03 - 06	108 MS*	152 MS	
	500 Scarabeo Classic	10 - 11	108 MS*	152 MS	
	500 Scarabeo ie	07 - 11	108 MS*	152 MS	

\* = 2 sets required / 2 jeux pour l'Avant.

Full compound selection, see under "Brake pad 1:1 Drawings" / Sélection complète de composés, voir "1:1 Schémas Plaquettes de frein".

**RECOMMENDED**1xx - 2xx = Scooter Pads  
5xx - 9xx = Street, Off Road & Racing Pads  
2xxx = Brake Shoes

APRILIA					
RXV	550	06 - 13	694 SI	790 SI	
SXV	550	06 - 13	842 RSI	790 RSI	
SXV	550 Van den Bosch Rep.	08 - 10	695 RST	790 RSI	
	600 Pegaso	90 - 92	641 HF	651 HF	
	600 Tuareg	86 - 87	588 HF	519 HF	
	600 Tuareg	88 - 89	641 HF	692 HF	
	600 Tuareg Wind	88 - 88	594 HF	519 HF	
	600 Tuareg Wind	90 - 94	641 HF	692 HF	
ETX	600	86 - 92	588 HF	519 HF	
	650 Moto	95 - 03	674 HF	692 HF	
	650 Pegaso	92 - 94	681 HF	651 HF	
	650 Pegaso	95 - 00	674 HS	692 HF	
	650 Pegaso Factory	07 - 09	842 HS	675 LS	
	650 Pegaso i.e.	01 - 04	674 HS	675 LS	
	650 Pegaso i.e. Tuscany Tibet Raid	04 - 04	674 HS	675 LS	
	650 Pegaso Strada	05 - 09	706 HS	675 LS	
	650 Pegaso Trail	06 - 08	674 HS	675 LS	
	650 Starck	96 - 01	674 HF	692 HF	
	660 Tuareg	22 - 24	674 HS*	675 LS	
	660 Tuono Factory	22 - 23	900 HS*	730 LS	
RS	660	20 - 22	900 HS*	730 LS	
RS	660 Extrem	23 - 23	900 HS*	730 LS	
RS	660 Trofeo	22 - 22	900 HS*	730 LS	
	750 Dorsoduro Factory	12 - 13	706 HS*	675 LS	
SL	750 Shiver GT, ABS	09 - 12	844 HS*	675 LS	
SL	750 Shiver, ABS	07 - 18	844 HS*	675 LS	
SMV	750 Dorsoduro	08 - 08	706 HS*	675 LS	
SMV	750 Dorsoduro	09 - 18	844 HS*	675 LS	
NA	850 Mana	07 - 07	844 HS*	675 LS	
NA	850 Mana GT, ABS	09 - 13	844 HS*	588 HF	
NA	850 Mana GT, ABS (Parking Brake)	09 - 13		879 HF	
NA	850 Mana, ABS	08 - 11	844 HS*	588 HF	
SRV	850	12 - 19	151 MS*	177 MS	
SRV	850 (Parking Brake)	12 - 19		209 HF	
	900 Dorsoduro	18 - 20	844 HS*	675 LS	
	900 Shiver	18 - 20	844 HS*	675 LS	
	1000 Blue Marlin	02 - 02	706 HS*	730 LS	
	1000 Tuono	03 - 10	900 HS*	730 LS	
ETV	1000 Caponord	01 - 08	674 HS*	730 LS	
ETV	1000 Caponord Rally Raid	04 - 08	674 HS*	730 LS	
RST	1000 Futura	01 - 03	706 HS*	671 LS	
RSV	1000	97 - 01	706 HS*	730 LS	
RSV	1000	02 - 03	762 HS*	730 LS	
RSV	1000 Factory Pista	04 - 04	762 HS*	730 LS	
RSV	1000 Falco SL, R	00 - 04	706 HS*	730 LS	
RSV	1000 Nera	04 - 04	762 HS*	730 LS	
RSV	1000 R	00 - 00	706 HS*	730 LS	
RSV	1000 R	01 - 07	762 HS*	730 LS	
RSV	1000 R Factory	04 - 08	762 HS*	730 LS	
RSV	1000 SP	00 - 00	706 HS*	730 LS	
RSV	1000 Tuono Fighter	03 - 05	706 HS*	730 LS	
RSV	1000 Tuono R	03 - 03	762 HS*	730 LS	
RSV	1000 Tuono R Factory, ABS	06 - 12	762 HS*	730 LS	
RSV	1000 Tuono R, ABS	04 - 12	706 HS*	730 LS	
RSV	1000 Tuono V4 R	11 - 13	706 HS*	730 LS	
RSV	1000 Tuono V4 R	14 - 14	900 HS*	730 LS	
RSV4	1000 , ABS	09 - 13	841 HS*	730 LS	
RSV4	1000 Factory	09 - 11	841 HS*	730 LS	
RSV4	1000 Factory APRC ABS	13 - 16	841 HS*	730 LS	
RSV4-R	1000 , ABS APRC	10 - 10	841 HS*	730 LS	
RSV4-RF	1000	15 - 20	901 HS*	730 LS	
RSV4-RR	1000	15 - 20	901 HS*	730 LS	
RSV	1100 Tuono V4	15 - 15	900 HS*	730 LS	
RSV	1100 Tuono V4 Factory	15 - 16	900 HS*	730 LS	
RSV	1100 Tuono V4 Factory	17 - 18	901 HS*	730 LS	
RSV	1100 Tuono V4 RR	15 - 16	900 HS*	730 LS	
RSV	1100 Tuono V4 RR	17 - 19	901 HS*	730 LS	
RSV4	1100 Factory	19 - 23	841 HS*	730 LS	
	1200 Caponord	13 - 19	900 HS*	675 LS	
	1200 Caponord Rally	15 - 19	900 HS*	675 LS	
	1200 Caponord Travel Pack	16 - 19	900 HS*	675 LS	
	1200 Dorsoduro, ABS	11 - 14	706 HS*	675 LS	

**RECOMMENDED**1xx - 2xx = Scooter Pads  
5xx - 9xx = Street, Off Road & Racing Pads  
2xxx = Brake Shoes

ARCTIC CAT					
	50 2WD	04 - 06	2048*		
	50 DVX	06 - 08	2048*	638 SI	
	90 2WD	02 - 04	2048*		
	90 DVX	06 - 14	2048*	638 SI	
	250 2x4	05 - 06	822 ATS*	822 ATS	
	250 2x4 (Man. Hand Brake)	99 - 04		827 ATS	
	250 2x4/4x4	99 - 04	758 ATS*	758 ATS	
	250 4x4 (Man. Hand Brake)	00 - 04		827 ATS	
	250 DVX	06 - 09	810 SI*	775 SI	
	300 2x4	10 - 13	822 ATS*	822 ATS	
	300 2x4 (Man. Hand Brake)	98 - 04		827 ATS	
	300 2x4/4x4	98 - 04	758 ATS*	758 ATS	
	300 4x4	05 - 05	822 ATS*	822 ATS	
	300 4x4 (Man. Hand Brake)	98 - 05		827 ATS	
	300 DVX	09 - 16	810 SI*	775 SI	
	375 2x4/4x4	02 - 02	758 ATS*	758 ATS	
	375 2x4/4x4 (Man. Hand Brake)	02 - 02		827 ATS	
	400 2x4 (Man. Hand Brake)	98 - 02		827 ATS	
	400 2x4/4x4 (FIS)	02 - 04	758 ATS*	758 ATS	
	400 2x4/4x4 (FIS)				
	400 2x4/4x4 (FIS) (Man. Hand Brake)	02 - 04		827 ATS	
	400 2x4/4x4 (FIS)				
	Aut. (Man. Hand Brake)	03 - 04		827 ATS	
	400 2x4/4x4 (FIS)	05 - 07	822 ATS*	822 ATS	
	400 2x4/4x4 (FIS)				
	(Man. Hand Brake)	05 - 08		758 ATS	
	400 2x4/4x4	98 - 04	758 ATS*	758 ATS	
	400 4x4 (Man. Hand Brake)	98 - 04		827 ATS	
	400 DVX	04 - 08	592 SI*	649 SI	
	400 TBX 4x4	04 - 04	758 ATS*	758 ATS	
	400 TBX 4x4 (Man. Hand Brake)	04 - 04		827 ATS	
TRV	400	09 - 13	822 ATS*	822 ATS	
	440 Bear Cat	96 - 97		758 ATS	
	450 H1	10 - 10	822 ATS*	822 ATS	
XC	450	11 - 14	822 ATS*	822 ATS	
	454 Arctic Cat 4x4	98 - 98	758 ATS*	758 ATS	
	454 Bear Cat 2x4/4x4	96 - 98	758 ATS*	758 ATS	
	454 Bear Cat 2x4/4x4				
	(Man. Hand Brake)	98 - 98		827 ATS	
	500 2x4 (FIS)(Man. Hand Brake)	02 - 02		827 ATS	
	500 2x4 (Man. Hand Brake)	02 - 02		827 ATS	
	500 2x4/4x4	98 - 04	758 ATS*	758 ATS	
	500 2x4/4x4 (FIS)	02 - 04	758 ATS*	758 ATS	
	500 2x4/4x4 (FIS)	05 - 09	822 ATS*	822 ATS	
	500 4x4 (FIS) Aut.				
	(Man. Hand Brake)	02 - 03		827 ATS	
	500 4x4 (FIS)(Man. Hand Brake)	02 - 03		827 ATS	
	500 4x4 (Man. Hand Brake)	98 - 02		827 ATS	
	500 TBX 4x4	02 - 04	758 ATS*	758 ATS	
	500 TBX 4x4	05 - 06	822 ATS*	822 ATS	
	500 TBX 4x4 (Man. Hand Brake)	03 - 04		827 ATS	
	500 TBX 4x4 Aut.				
	(Man. Hand Brake)	02 - 02		827 ATS	
	500 TRV 4x4	03 - 04	758 ATS*	758 ATS	
	500 TRV 4x4	05 - 06	822 ATS*	822 ATS	
	500 TRV 4x4 (Man. Hand Brake)	03 - 04		827 ATS	
	550 H1	09 - 13	822 ATS*	822 ATS	
	550 LTD	09 - 12	822 ATS*	822 ATS	
	550 Prowler	09 - 14	822 ATS*	822 ATS	
TRV	550	09 - 14	822 ATS*	822 ATS	
	650 H1 4x4 Aut.	05 - 11	822 ATS*	822 ATS	
	650 Prowler	06 - 08	822 ATS*	822 ATS	
	650 V2 4x4 Aut.	05 - 06	822 ATS*	822 ATS	
	650 V2 4x4 Aut. LE	05 - 06	822 ATS*	822 ATS	
	700 Diesel	06 - 14	822 ATS*	822 ATS	
	700 H1	09 - 10	822 ATS*	822 ATS	
	700 Prowler	08 - 08	822 ATS*	822 ATS	
	700 Wildcat Sport	15 - 18	946 ATS*	822 ATS	
	700 Wildcat Sport LTD.	16 - 18	946 ATS*	822 ATS	
	700 Wildcat Sport LTD. EPS	17 - 18	946 ATS*	822 ATS	
	700 Wildcat Sport SE EPS	17 - 19	946 ATS*	822 ATS	
	700 Wildcat Sport XT	15 - 18	946 ATS*	822 ATS	

\* = 2 sets required / 2 jeux pour l'Avant.

Full compound selection, see under "Brake pad 1:1 Drawings" / Sélection complète de composés, voir "1:1 Schémas Plaquettes de frein".





**RECOMMENDED**

1xx - 2xx = Scooter Pads  
5xx - 9xx = Street, Off Road & Racing Pads  
2xxx = Brake Shoes



ARCTIC CAT				
	700 Wildcat Sport XT EPS	16 - 18	946 ATS*	822 ATS
TBX	700	12 - 14	822 ATS*	822 ATS
TRV	700	09 - 12	822 ATS*	822 ATS
	1000 Prowler	09 - 09	822 ATS*	822 ATS
	1000 Thundercat	09 - 14	822 ATS*	822 ATS
	1000 Wildcat 4X	16 - 18	912 ATS*	822 ATS
	1000 Wildcat X	16 - 18	912 ATS*	822 ATS
	1000 Wildcat X Ltd.	17 - 18	912 ATS*	822 ATS
	1000 Wildcat X SE	17 - 18	912 ATS*	822 ATS
TRV	1000	09 - 14	822 ATS*	822 ATS
ARMSTRONG				
MX	500	86 - 86	519 SI	
MX	600	86 - 86	519 SI	
ASPES				
	125 Sintesi	88 - 88	601 HF	519 HF
	125 Yuma	76 - 79	560 HF	
ATALA				
	25 Carosello	97 - 97	123 HF	
AT10	25	97 - 97	114 HF	
	50 Carosello	97 - 01	123 HF	
	50 Hacker	95 - 00	123 HF	2181
	50 Skeggia	98 - 00	114 HF	
AT10	50	97 - 97	114 HF	
	125 Hacker	98 - 98	123 CT	
BAOXIN				
BX	125 L	97 - 97	691 HF	
BARIGO				
	Scooter electric	97 - 97	105 HF	2028
BATAVUS				
	50 Grand Prix	80 - 80	546 HF	
BENDA				
LFS	700	23 - 23	900 HS*	730 LS
LFX	700	23 - 23	900 HS*	730 LS
BENELLI				
	50 49X (Quattro Nove)	08 - 13	141 HF	
	50 Chrono	92 - 93	109 HF	2012
	50 Chrono	94 - 94	123 HF	2012
	50 Devil	92 - 92	601 HF	595 HF
	50 Naked	02 - 02	143 HF	2028
	50 Nemo, Quadra	94 - 94	123 HF	2012
	50 Pepe	99 - 11	123 HF	2012
	50 Spring	92 - 92	601 HF	595 HF
491	50 GT, Sport	98 - 99	123 HF	2012
491	50 Naked	99 - 02	123 HF	2012
491	50 Racing	99 - 04	123 HF	123 HF
491	50 RR, -GP	00 - 02	123 HF	123 HF
491	50 ST	01 - 02	123 HF	2012
491	50 Superbike	99 - 04	123 HF	123 HF
K2	50 Air	98 - 01	123 HF	123 HF
K2	50 LC	99 - 01	123 HF	123 HF
K2	50 Namur	99 - 99	123 HF	123 HF
KB-X	50 Race	14 - 14	619 HF	
	100 Naked	02 - 03	123 HF	
K2	100 Biposto	99 - 01	123 HF	
LX	100 Pepe	02 - 06	123 HF	2028
	124 T	83 - 85	519 HF	
	125 2CE	76 - 78	519 HF	
	125 Adiva	00 - 05	123 CT	166 CT
	125 Caffenero Left	08 - 11	197 CT	197 CT
	125 Caffenero Right	08 - 11	134 CT	
	125 Custom	85 - 85	519 HF	
	125 Jarno	89 - 89	601 HF*	519 HF
	125 MJ	10 - 10	197 CT	197 CT
	125 Sport	82 - 89	519 HF	



**RECOMMENDED**

1xx - 2xx = Scooter Pads  
5xx - 9xx = Street, Off Road & Racing Pads  
2xxx = Brake Shoes



BENELLI				
	125 T	76 - 76	519 HF	
	125 TT	86 - 86	519 HF	
	125 Velvet, Velvet Touring	99 - 99	123 CT	164 CT
	125 Worx	17 - 18	968 HF	
666	125 Born in Hell	98 - 98	706 HF	697 HF
BKX	125	23 - 23	706 HF	832 HF
BKX	125 S	23 - 23	706 HF	832 HF
BN	125	18 - 19	968 HF	
BX	125	89 - 89	601 HF	519 SI
BKX	125	88 - 88	519 HF	559 HF
E	125 L.C.	85 - 85	519 HF	
TNT	125	17 - 17	558 HF	
TNT	125	18 - 19	968 HF	915 HF
TNT	135	18 - 19	968 HF	915 HF
	150 Adiva	00 - 05	123 CT	166 CT
	150 MJ	10 - 10	197 CT	197 CT
	150 Velvet, Velvet Touring	00 - 12	123 CT	164 CT
	250 2CE	76 - 76	519 HF	
	250 Caffenero Left	08 - 14	197 MS	196 MS
	250 Caffenero Right	08 - 14	134 MS	
	250 Disc	76 - 76	519 HF	
	250 Leoncino	18 - 20	933 HS*	832 LS
	250 Velvet, Velvet Touring	99 - 08	123 CT	164 CT
BKX	250	23 - 23	706 HF	832 HF
BKX	250 S	23 - 23	706 HF	832 HF
BN	251	15 - 19	933 HS	832 LS
TRK	251	19 - 24	933 HS	832 LS
	254	83 - 83	532 HF	
	300 Tornado	24 - 24	933 HS*	832 LS
BN	302	14 - 14	706 HS*	730 LS
BN	302	15 - 15	933 HS*	832 LS
BN	302 R	17 - 19	933 HS*	832 LS
BN	302 S	18 - 19	933 HS*	832 LS
BN	302 Tornado	16 - 16	933 HS*	832 LS
	304	83 - 83	519 HF	
	350 4T Turismo	80 - 80	519 HF	506 HF
	350 Zenzero	12 - 15	163 CT	101 CT
	354	78 - 82	519 HF*	506 HF
	354 Sport	83 - 85	519 HF*	519 HF
	400 Imperiale	19 - 24	983 HS	832 LS
	400 Velvet Dusk	03 - 04	120 CT	123 CT
	402 S	18 - 19	706 HS*	832 LS
BX	449 Cross	07 - 09	671 RSI	675 RSI
BX	449 Supermotard	08 - 10	762 RST	675 RSI
	500 -4	76 - 76	519 HF*	
	500 4T	76 - 76	519 HF	506 HF
	500 C	19 - 19	762 HS*	730 LS
	500 Leoncino	16 - 17	706 HS*	730 LS
	500 Leoncino Cinquecento	18 - 19	762 HS*	832 LS
	500 Leoncino Trail	17 - 23	983 HS*	832 LS
	500 Tornado	24 - 24	900 HS*	675 LS
	500 Tornado Naked	23 - 23	762 HS*	832 LS
	502 C	23 - 24	762 HS*	730 LS
TRK	502	16 - 17	706 HS*	730 LS
TRK	502	18 - 24	762 HS*	832 LS
TRK	502 X	17 - 24	983 HS*	832 LS
BX	505 Enduro	08 - 08	671 SI	675 SI
BN	600	12 - 13	706 HS*	730 LS
BN	600	14 - 17	762 HS*	730 LS
BN	600 GT	14 - 15	762 HS*	730 LS
T	600 Tornado Naked	20 - 20	762 HS*	730 LS
	654 Sport	83 - 83	519 HF*	519 HF
TRK	702	24 - 24	762 HS*	675 LS
TRK	702 X	24 - 24	983 HS*	675 LS
	750 Sei	75 - 78	506 HF*	
	752 S	18 - 18	762 HS*	832 LS
	752 S	20 - 24	900 HS*	730 LS
	756 Cue	07 - 09	762 HS*	730 LS
	756 Cue	10 - 12	706 HS*	730 LS
	800 Leoncino	20 - 21	900 HS*	730 LS
	800 Leoncino	22 - 23	762 HS*	730 LS
	800 Leoncino Trail	22 - 23	762 HS*	730 LS

\* = 2 sets required / 2 jeux pour l'Avant.

Full compound selection, see under "Brake pad 1:1 Drawings" / Sélection complète de composés, voir "1:1 Schémas Plaquettes de frein".

**RECOMMENDED**1xx - 2xx = Scooter Pads  
5xx - 9xx = Street, Off Road & Racing Pads  
2xxx = Brake Shoes

<b>BENELLI</b>					
TRK	800	21 - 23	900 HS*	730 LS	
	899 Trek	07 - 12	706 HS*	730 LS	
TNT	899	07 - 15	706 HS*	730 LS	
TNT	899 Century Racer	11 - 11	762 HS*	730 LS	
	900 Sei	81 - 83	554 HF*		
	900 Sei	84 - 84	506 HF*	506 HF	
	900 Tornado 3	00 - 06	706 HS*	519 LS	
	900 Tornado TRE	03 - 06	762 HS*	730 LS	
	900 Tornado TRE RS	04 - 06	762 HS*	730 LS	
TNT	1100	04 - 04	706 HS*	519 LS	
TNT	1130	05 - 14	706 HS*	730 LS	
TNT	1130 Cafe Racer	05 - 13	762 HS*	730 LS	
TNT	1130 Century Racer	11 - 12	762 HS*	730 LS	
TNT	1130 Officine	07 - 07	762 HS*	730 LS	
TNT	1130 R	17 - 17	841 HS*	730 LS	
TNT	1130 Sport	05 - 08	762 HS*	730 LS	
TNT	1130 Titanium	05 - 08	762 HS*	730 LS	
TNT	1130 Trek	06 - 12	706 HS*	730 LS	
TNT	1130 Trek Amazonas	07 - 15	706 HS*	730 LS	

<b>BETA</b>					
	50 AJP Caliper incl. pin/spring	90 - 19	188 HF		
	50 Ark AirCooled	99 - 12	123 HF		
	50 Ark K Series	97 - 05	123 HF	123 HF	
	50 Ark LC	99 - 12	123 HF	123 HF	
	50 Chrono 13	94 - 99	123 HF	2012	
	50 Crono 502	97 - 02	138 HF		
	50 Eikon	99 - 03	105 HF	105 HF	
	50 Eikon	04 - 07	123 HF	152 HF	
	50 ProRace 12/10	04 - 04	803 RSI	803 RSI	
	50 Quadra	95 - 96	123 HF	2012	
	50 Quadra	97 - 00	138 HF		
	50 Rev	00 - 09	559 HF	559 HF	
	50 Squirrel	83 - 83	532 HF		
	50 Super Trial	92 - 92	559 HF	636 HF	
	50 Techno	96 - 96	105 HF	105 HF	
	50 Tempo	92 - 96	105 HF	2012	
	50 Tempo	97 - 98	138 HF		
	50 Tempo	99 - 99	123 HF		
	50 Tempo (13" wheels)	00 - 02	123 HF		
	50 Tempo (16" wheels)	00 - 02	123 HF		
AE	50 Four Twin	88 - 88	595 HF		
ALP	50	91 - 00	595 HF	607 HF	
KR	50	86 - 87	519 HF		
KR	50 Twin	88 - 88	519 HF	519 HF	
MX	50 Enduro	92 - 92	607 HF	636 HF	
RR	50 Enduro	99 - 09	148 HF	105 HF	
RR	50 Enduro	10 - 18	168 HF	199 HF	
RR	50 Enduro Alu	04 - 07	120 HF		
RR	50 Pro Race	98 - 98	148 HF	105 HF	
RR	50 Standard	99 - 08	148 HF	105 HF	
RR	50 Supermotard	99 - 03	148 HF	105 HF	
RR	50 Supermotard	04 - 07	105 HF	105 HF	
RR	50 Supermotard	08 - 13	168 HF	199 HF	
RR	50 Supermotard Alu	04 - 05	120 HF		
RV	50	88 - 88	595 HF		
RX	50	84 - 84	605 HF		
ST	50	97 - 97	559 HF	559 HF	
VRS	50	86 - 86	595 HF		
	80 EVO	09 - 10	802 RSI		
	80 EVO Junior	10 - 11	559 HF	559 HF	
	80 Rev	00 - 07	559 HF	559 HF	
	80 Rev	08 - 10	802 RSI	896 RSI	
	125 Eikon	99 - 03	105 CT	105 CT	
	125 Eikon	04 - 06	123 CT	152 CT	
	125 EVO	09 - 14	802 RSI	895 RSI	
	125 Jonathan	99 - 05	566 HF	675 HF	
	125 M4	06 - 06	774 HF	861 HF	
	125 Rev 3	00 - 05	802 RSI	802 RSI	
	125 Rev 3	06 - 08	802 RSI	896 RSI	
	125 TS, Custom	83 - 83	560 HF		
	125 Urban	10 - 15	774 HF	861 HF	

**RECOMMENDED**1xx - 2xx = Scooter Pads  
5xx - 9xx = Street, Off Road & Racing Pads  
2xxx = Brake Shoes

<b>BETA</b>					
ALP	125	90 - 90	595 HF	607 HF	
ALP	125	99 - 09	559 RSI	559 RSI	
ALP	125 4-stroke	00 - 05	559 RSI	559 RSI	
ALP	125 4-stroke	06 - 09	774 HF	861 HF	
MG	125	83 - 83	532 HF		
RR	125	18 - 19	694 SI	790 SI	
RR	125 Enduro 4T	10 - 15	774 HF	861 HF	
RR	125 Supermotard	08 - 09	774 HF	861 HF	
RX	125	84 - 84	605 HF		
SR	125 34	89 - 89	559 HF	636 HF	
TR	125 32,33	86 - 87	595 HF		
TR	125 34	88 - 88	595 HF	607 HF	
TR	125 34	92 - 92	672 HF	636 HF	
TR	125 34,35	89 - 90	559 RSI	559 RSI	
TR	125 36	92 - 92	672 HF	636 HF	
TRIAL	125	97 - 97	559 RSI	636 HF	
	150 Eikon	99 - 03	105 CT	105 CT	
	150 Eikon	04 - 04	123 CT	152 CT	
R	150	10 - 13	814 HF		
	200 EVO	09 - 14	802 RSI	895 RSI	
	200 Rev 3	06 - 08	802 RSI	896 RSI	
	200 Urban	10 - 10	774 HF	861 HF	
ALP	200 4-stroke	00 - 05	559 RSI	559 RSI	
ALP	200 4-stroke	06 - 20	774 HF	861 HF	
	240 Super Trial	92 - 92	559 RSI	636 HF	
ALP	240	92 - 92	559 RSI	636 HF	
ALP	240	96 - 96	559 RSI	519 RSI	
TR	240 33	86 - 88	595 HF		
	250 4-T Rev 3	07 - 11	802 RSI	896 RSI	
	250 Eikon	99 - 10	105 CT	105 CT	
	250 EVO (2-T / 4-T)	09 - 14	802 RSI	895 RSI	
	250 Rev 3	00 - 04	802 RSI	802 RSI	
	250 Rev 3	05 - 09	802 RSI	896 RSI	
	250 Techno	96 - 96	559 RSI	559 RSI	
	250 Zero	91 - 91	559 RSI	636 HF	
ALP	250	92 - 92	559 RSI	636 HF	
ALP	250	97 - 03	559 RSI	559 RSI	
CR	250	83 - 83	519 SI		
RR	250	05 - 09	694 SI	790 SI	
	260 Synt	92 - 92	595 HF	636 HF	
	260 Zero	91 - 91	559 RSI	636 HF	
ALP	260	96 - 96	559 RSI	519 RSI	
TR	260 34	86 - 88	595 HF	607 HF	
TR	260 34,35,ZERO	89 - 92	559 RSI	636 HF	
	270 Rev 3	00 - 04	802 RSI	802 RSI	
	270 Rev 3	05 - 08	802 RSI	896 RSI	
	290 EVO	09 - 13	802 RSI	895 RSI	
	300 Crosstrainer	15 - 15	694 SI	790 SI	
	300 EVO	09 - 15	802 RSI	895 RSI	
RR	300	13 - 19	694 SI	790 SI	
	350 4.0 Motard	04 - 06	566 RSI	574 RSI	
	350 Euro	99 - 03	566 HF	675 HF	
	350 Jonathan	02 - 03	566 HF	675 HF	
	350 M4 (Brembo cal.)	06 - 07	566 HF	861 HF	
ALP	350 4.0	04 - 05	774 HF	574 RSI	
ALP	350 4.0	06 - 18	774 HF	861 HF	
RR	350 Efi	15 - 15	694 SI	790 SI	
RR	350 Efi Racing	15 - 15	694 SI	790 SI	
RR	350 Enduro	12 - 14	694 SI	790 SI	
RR	390	15 - 19	694 SI	790 SI	
RR	400 Enduro	05 - 05	694 SI	790 SI	
RR	430	15 - 19	694 SI	790 SI	
RR	430 Racing	15 - 19	694 SI	790 SI	
	450 RX	24 - 24	694 RSI	790 RSI	
RR	450 Cross Country	12 - 12	694 SI	790 SI	
RR	450 Enduro	05 - 07	694 SI	790 SI	
RR	480	15 - 19	694 SI	790 SI	
RR	480 Racing	15 - 19	694 SI	790 SI	
RR	498 Enduro	12 - 14	694 SI	790 SI	
	500 GS, RV	84 - 84	519 HF		
RR	525 Enduro	05 - 13	694 SI	790 SI	

\* = 2 sets required / 2 jeux pour l'Avant.

Full compound selection, see under "Brake pad 1:1 Drawings" / Sélection complète de composés, voir "1:1 Schémas Plaquettes de frein".





**RECOMMENDED**

1xx - 2xx = Scooter Pads  
5xx - 9xx = Street, Off Road & Racing Pads  
2xxx = Brake Shoes



BIMOTA				
	all models	82 - 88	506 HF*	506 HF
BBX	300 Enduro	12 - 12	694 SI	790 SI
YB7	400	89 - 89	566 HF*	519 HF
BX	450	23 - 23	694 SI	790 SI
	500 Vdue	97 - 00	566 HF*	519 HF
BBX	508 Enduro	12 - 12	694 SI	604 SI
	600 Bellaria	91 - 91	566 HF*	519 HF
YB9	600 SRI	97 - 97	566 HF*	519 HF
BB1	650 Supermono	97 - 00	566 HF*	519 HF
SB7	750	96 - 88	566 HF*	519 HF
YB4	750	89 - 89	566 HF*	519 HF
3D	800 Tesi	16 - 16	841 HS*	730 LS
1D	851 Tesi	91 - 91	566 HF*	519 HF
1D	900 Tesi	93 - 93	566 HF*	519 HF
DB2	900	92 - 00	566 HF*	519 HF
DB3	900 Mantra	97 - 00	566 HF*	519 HF
DB4	900	99 - 00	706 HS*	519 LS
1D	906 Tesi	91 - 91	566 HF*	519 HF
	1000 Furano	92 - 93	566 HF*	519 HF
	1000 Tera	24 - 24	841 HS*	730 LS
	1000 Tesi H2	21 - 23	841 HS*	730 LS
2D	1000 Tesi	04 - 06	566 HS*	519 LS
BB3	1000	14 - 18	901 HS*	730 LS
DB5	1000	05 - 11	762 HS*	730 LS
DB5	1000 S	07 - 11	762 HS*	730 LS
DB6	1000 Delirio	07 - 09	762 HS*	730 LS
KB4	1000	23 - 23	841 HS*	730 LS
KB4	1000 RC	23 - 23	841 HS*	730 LS
SB3	1000 D	83 - 83	506 HF*	506 HF
SB8	1000 R	98 - 00	706 HS*	519 LS
SB8K	1000	06 - 06	706 HS*	519 LS
SB8K	1000 Santamonica	07 - 09	762 HS*	519 LS
YB11	1000	97 - 00	566 HF*	519 HF
YB6	1000	89 - 89	566 HF*	519 HF
YB8	1000	90 - 90	566 HF*	519 HF
	1002 Dieci	91 - 91	566 HF*	519 HF
DB10	1078 Bimotard	12 - 12	762 HS*	730 LS
DB5	1078 RE	12 - 12	762 HS*	730 LS
DB7	1098	08 - 08	762 HS*	730 LS
DB7	1099	09 - 09	901 HS*	519 LS
3D	1100 Tesi	07 - 11	762 HS*	730 LS
DB6R	1100 Delirio	08 - 09	762 HS*	730 LS
DBX	1100	13 - 18	674 HS*	671 LS
SB6	1100	97 - 00	566 HF*	519 HF
DB8	1198	10 - 14	901 HS*	730 LS
	1200 Impeto	16 - 17	841 HS*	730 LS
DB11	1200 VLX	13 - 13	901 HS*	730 LS
DB12	1200	12 - 12	762 HS*	730 LS
DB9	1200 Brivido	12 - 18	762 HS*	730 LS
BLATA				
	125 Enduro	07 - 08	821 HS	559 HF
	125 Motard	07 - 08	821 HS	559 HF
BMW				
	CE 04	21 - 24	231 MS	175 MS
C	Evolution	12 - 18	183 MS*	183 MS
C	Evolution (Parking Brake)	12 - 18		209 HF
C1	125	00 - 03	176 CT	175 CT
C1	200	02 - 04	176 CT	175 CT
G	310 GS	17 - 24	877 HS	675 LS
G	310 R	16 - 24	877 HS	675 LS
C	400 GT	19 - 24	231 MS*	175 MS
C	400 X	18 - 24	231 MS*	175 MS
G	450 SMR	09 - 10	762 RST	791 RSI
G	450 X	08 - 10	671 SI	791 SI
R45	450	78 - 79	527 HF*	2139
R45	450	80 - 85	527 HF*	2140
C	600 Sport	12 - 15	183 MS*	183 MS
C	600 Sport (Parking Brake)	12 - 15		209 HF
R60	600 Series	74 - 80		2139
R60/7	600	76 - 77	520 HF	2139



**RECOMMENDED**

1xx - 2xx = Scooter Pads  
5xx - 9xx = Street, Off Road & Racing Pads  
2xxx = Brake Shoes



BMW				
C	650 GT	12 - 21	183 MS*	183 MS
C	650 GT (Parking Brake)	12 - 15		209 HF
C	650 Sport	16 - 20	183 MS*	183 MS
F	650 , ST	94 - 00	674 HF	675 HF
F	650 CS Scarver	02 - 06	674 HS	675 LS
F	650 GS	08 - 12	674 HS	675 LS
F	650 GS ABS	01 - 07	674 HF	675 HF
F	650 GS ABS	08 - 12	674 HS	675 LS
F	650 GS Dakar	01 - 07	674 HF	675 HF
F	650 GS, Rally	01 - 07	674 HF	675 HF
F	650 ST Strada	97 - 01	674 HF	675 HF
G	650 GS	09 - 15	674 HS	675 LS
G	650 GS Sertao	12 - 14	674 HS	675 LS
G	650 Xchallenge	06 - 07	674 HS	675 LS
G	650 Xcountry	06 - 09	674 HS	675 LS
G	650 Xmoto	06 - 07	706 HS	675 LS
R65	650	78 - 79	527 HF	2139
R65	650	80 - 80		2140
R65	650 GS	87 - 92	506 HF	2140
R65	650 LS	82 - 85	506 HF*	2141
R65/1	650	86 - 86	554 HF*	506 HF
F	700 GS	13 - 16	674 HS*	675 LS
R70	700 Series	74 - 80		2139
F	750 GS	18 - 24	674 HS*	675 LS
K75	750	90 - 90	640 HS	506 LS
K75	750 C	85 - 88	506 HF*	2140
K75	750 RT	91 - 96	640 HS*	506 LS
K75	750 S, C	85 - 95	506 HF*	506 HF
R75	750	86 - 86		2140
R75/6	750	74 - 76	520 HF	2139
R75/7	750	76 - 77	520 HF	2139
	800 Touring	87 - 87		2140
F	800 GS	08 - 24	674 HS*	675 LS
F	800 GT	13 - 20	706 HS*	675 LS
F	800 R	09 - 14	706 HS*	675 LS
F	800 R	15 - 18	900 HS*	675 LS
F	800 S	06 - 10	706 HS*	675 LS
F	800 ST	06 - 12	706 HS*	675 LS
F	800 ST Touring	11 - 12	706 HS*	675 LS
R80	800	77 - 85	506 HF	2140
R80	800	86 - 88	554 HF	2140
R80	800 G/S P.-D.	86 - 86	506 HF	2140
R80	800 GS	81 - 87	506 HF	2140
R80	800 GS	91 - 92	506 HS	2140
R80	800 GS Mystic	91 - 95	554 HS*	2140
R80	800 GS Paris Dakar	88 - 94	554 HS	
R80	800 R	91 - 95	644 HS*	506 LS
R80	800 RT	83 - 83	506 HF*	2140
R80	800 RT	84 - 85	554 HF*	2140
R80/7	800	77 - 78	520 HF	2139
R80/7	800	79 - 81	520 HF	506 HF
F	850 GS	18 - 23	674 HS*	675 LS
F	850 GS Adventure	18 - 23	674 HS*	675 LS
R	850 C	99 - 01	703 HS*	742 LS
R	850 GS	99 - 07	703 HS*	742 LS
R	850 R	96 - 02	703 HS*	742 LS
R	850 R	03 - 07	778 HS*	742 LS
R	850 RT	96 - 01	703 HS*	675 LS
R	850 RT With Integral ABS	01 - 06	796 HS*	742 LS
F	900 GS	24 - 24	674 HS*	675 LS
F	900 GS Adventure	24 - 24	674 HS*	675 LS
F	900 R	20 - 24	900 HS*	675 LS
F	900 XR	20 - 24	900 HS*	675 LS
R	900 RT	05 - 13	796 HS*	742 LS
R90	900 S	73 - 76	520 HF*	2139
R90	900 Series	74 - 80		2139
R90/6	900	73 - 76	520 HF	2139
K1	1000	89 - 89	644 HS*	506 LS
K100	1000 LT	87 - 87	506 HF*	506 HF
K100	1000 LT	92 - 94	644 HS*	506 LS
K100	1000 LT ABS	89 - 89	640 HS*	506 LS
K100	1000 RS	90 - 92	644 HS*	506 LS

\* = 2 sets required / 2 jeux pour l'Avant.

Full compound selection, see under "Brake pad 1:1 Drawings" / Sélection complète de composés, voir "1:1 Schémas Plaquettes de frein".

**RECOMMENDED**

1xx - 2xx = Scooter Pads  
5xx - 9xx = Street, Off Road & Racing Pads  
2xxx = Brake Shoes



BMW					
K100	1000 RS ABS	88	- 89	640 HS*	506 LS
K100	1000 RS, RT	83	- 89	506 HF*	506 HF
M	1000 R	23	- 24	985 HS*	675 LS
M	1000 RR	21	- 24	985 HS*	984 LS
R100	1000	79	- 80		2139
R100	1000	81	- 84	506 HF*	506 HF
R100	1000 all models	81	- 84		2140
R100	1000 CS,RS, RT	81	- 84	506 HF*	506 HF
R100	1000 GS	87	- 94	554 HF	2140
R100	1000 GS Mystic	91	- 94	554 HS*	2140
R100	1000 R	91	- 95	644 HS*	506 LS
R100	1000 RS	76	- 80	520 HF*	506 HF
R100	1000 RS	93	- 95	640 HS*	506 LS
R100	1000 RT	91	- 95	554 HS*	2143
R100	1000 S	76	- 77	520 HF*	2139
R100	1000 S	78	- 80	520 HF*	506 HF
R100	1000 T	79	- 84	520 HF*	506 HF
R100/7	1000	78	- 80	520 HF	2139
S	1000 HP4 Race	17	- 18	845 DS-1*	942 LS
S	1000 R	13	- 19	870 HS*	675 LS
S	1000 R	20	- 24	960 HS*	675 LS
S	1000 RR (Brembo cal.)	09	- 18	870 HS*	675 LS
S	1000 RR (Hayes cal.)	19	- 21	960 HS*	675 LS
S	1000 RR (Nissin cal.)	21	- 24	985 HS*	675 LS
S	1000 RR HP4	12	- 14	901 HS*	675 LS
S	1000 XR	15	- 19	900 HS*	742 LS
S	1000 XR	20	- 23	960 HS*	742 LS
S	1000 XR	24	- 24	900 HS*	742 LS
K1100	1100 LT/SE	92	- 00	644 HS*	506 LS
K1100	1100 RS	93	- 96	644 HS*	506 LS
R	1100 GS	94	- 01	703 HS*	742 LS
R	1100 R Cast wheels	99	- 01	703 HS*	742 LS
R	1100 R Spoke wheels	99	- 06	703 HS*	742 LS
R	1100 RT Cast wheels	95	- 01	703 HS*	742 LS
R	1100 RT Spoke wheels	95	- 01	703 HS*	742 LS
R	1100 S	99	- 00	703 HS*	742 LS
R	1100 S With Integral ABS	01	- 05	778 HS*	742 LS
R	1100 S Without Integral ABS	01	- 05	796 HS*	742 LS
R1100	1100 RS	93	- 93	644 HS*	506 LS
R1100	1100 RS	94	- 01	703 HS*	506 LS
R	1150 GS	00	- 01	703 HS*	742 LS
R	1150 GS (Tokico cal.)	02	- 05	778 HS*	742 LS
R	1150 GS Adventurer (Brembo cal.)	02	- 05	796 HS*	742 LS
R	1150 R	01	- 06	778 HS*	742 LS
R	1150 R Rockster	03	- 05	778 HS*	742 LS
R	1150 RS	01	- 04	778 HS*	742 LS
R	1150 RT With Integral ABS	01	- 06	796 HS*	742 LS
	1200 HP2 Enduro	04	- 06	674 HS*	671 LS
	1200 HP2 Megamoto	06	- 08	796 HS*	742 LS
	1200 HP2 Sport	08	- 10	901 HS*	671 LS
K	1200 GT (K41) With Integral ABS	02	- 05	796 HS*	506 LS
K	1200 GT (K44) With Integral ABS	04	- 08	796 HS*	671 LS
K	1200 LT	99	- 00	703 HS*	746 HF
K	1200 LT With Integral ABS	01	- 08	778 HS*	746 HF
K	1200 R	05	- 08	778 HS*	742 LS
K	1200 R Sport	05	- 07	778 HS*	742 LS
K	1200 RS	97	- 00	703 HS*	506 LS
K	1200 RS	01	- 05	796 HS*	506 LS
K	1200 S	05	- 08	796 HS*	742 LS
R	1200 C	98	- 02	703 HS*	742 LS
R	1200 C Classic	03	- 04	778 HS*	742 LS
R	1200 C Independent	03	- 04	778 HS*	742 LS
R	1200 C Montauk	02	- 04	778 HS*	742 LS
R	1200 CL	03	- 04	778 HS*	746 HF
R	1200 GS	04	- 12	796 HS*	742 LS
R	1200 GS	13	- 18	900 HS*	674 LS
R	1200 GS Adventure	08	- 13	796 HS*	742 LS
R	1200 GS Adventure	14	- 18	900 HS*	674 LS
R	1200 GS Triple Black	11	- 16	796 HS*	742 LS
R	1200 NineT	14	- 23	900 HS*	671 LS
R	1200 NineT Pure	17	- 23	706 HS*	671 LS
R	1200 NineT Racer	17	- 20	706 HS*	671 LS

**RECOMMENDED**

1xx - 2xx = Scooter Pads  
5xx - 9xx = Street, Off Road & Racing Pads  
2xxx = Brake Shoes



BMW					
R	1200 NineT Scrambler	16	- 23	706 HS*	671 LS
R	1200 NineT Urban GS	17	- 23	706 HS*	671 LS
R	1200 R	07	- 14	778 HS*	742 LS
R	1200 R	15	- 18	900 HS*	674 LS
R	1200 RS	14	- 18	900 HS*	674 LS
R	1200 RT	06	- 13	796 HS*	742 LS
R	1200 RT	14	- 18	900 HS*	674 LS
R	1200 S	06	- 07	796 HS*	742 LS
R	1200 ST	06	- 07	796 HS*	742 LS
R12	1200	24	- 24	900 HS*	671 LS
R12	1200 NineT	24	- 24	900 HS*	671 LS
R	1250 GS	19	- 23	960 HS*	674 LS
R	1250 GS Adventure	19	- 24	960 HS*	674 LS
R	1250 R	19	- 24	900 HS*	674 LS
R	1250 RS	19	- 24	900 HS*	674 LS
R	1250 RT	19	- 24	960 HS*	674 LS
R	1250 RT Sport	19	- 20	960 HS*	674 LS
K	1300 GT	09	- 10	796 HS*	671 LS
K	1300 R	09	- 15	778 HS*	742 LS
K	1300 R Dynamic	11	- 15	778 HS*	742 LS
K	1300 S	09	- 15	796 HS*	742 LS
R	1300 GS	24	- 24	1004 HS*	1005 LS
K	1600 B	17	- 24	778 HS*	674 LS
K	1600 Grand America	18	- 24	778 HS*	674 LS
K	1600 GT	11	- 24	778 HS*	674 LS
K	1600 GTL	11	- 24	778 HS*	674 LS
R18	1800	21	- 24	995 HS*	995 LS
R18	1800 100 Years	24	- 24	995 HS*	995 LS
R18	1800 B	22	- 24	995 HS*	995 LS
R18	1800 Classic	21	- 24	995 HS*	995 LS
R18	1800 Roctane	24	- 24	995 HS*	995 LS
R18	1800 Transcontinental	22	- 24	995 HS*	995 LS
<b>BOMBARDIER</b>					
	50 Quest	03	- 04	2048*	2041
DS	50	02	- 06	2048*	2041
	90 Quest	03	- 04	2048*	2041
DS	90	02	- 06	2048*	2041
	200 Rally 2x4	03	- 04	544 SI*	
DS	250 Left	06	- 06	754 SI	754 SI
DS	250 Right	06	- 06	767 SI	
	330 Outlander Left	03	- 06	754 SI	754 SI
	330 Outlander Right	03	- 06	767 SI	
	400 Outlander Left	03	- 06	754 SI	754 SI
	400 Outlander Right	03	- 06	767 SI	
	400 Outlander Max Left	03	- 06	754 SI	754 SI
	400 Outlander Max Right	03	- 06	767 SI	
	500 Quest Left	02	- 06	754 SI	754 SI
	500 Quest Right	02	- 06	767 SI	
	500 Traxter 4x4	99	- 00	730 HF*	730 HF
	500 Traxter 4x4 Left	01	- 06	754 SI	767 SI
	500 Traxter 4x4 Right	01	- 06	767 SI	
	500 Traxter Max Left	03	- 05	754 SI	767 SI
	500 Traxter Max Right	03	- 05	767 SI	
	650 Quest Left	02	- 06	754 SI	754 SI
	650 Quest Right	02	- 06	767 SI	
	650 Quest Max Left	03	- 06	754 SI	767 SI
	650 Quest Max Right	03	- 06	767 SI	
	650 Traxter Max Left	03	- 05	754 SI	767 SI
	650 Traxter Max Right	03	- 05	767 SI	
DS	650 Left	01	- 06	754 SI	754 SI
DS	650 Right	01	- 06	767 SI	
	800 Outlander Left	06	- 06	754 SI	754 SI
	800 Outlander Right	06	- 06	767 SI	
	800 Outlander XT Left	06	- 06	754 SI	754 SI
	800 Outlander XT Right	06	- 06	767 SI	
<b>BORILE</b>					
B	500 CR, MT	02	- 04	566 HF	675 HF
<b>BRAMMO</b>					
	Empulse	14	- 16	706 H.HS*	730 LS

\* = 2 sets required / 2 jeux pour l'Avant.

Full compound selection, see under "Brake pad 1:1 Drawings" / Sélection complète de composés, voir "1:1 Schémas Plaquettes de frein".





**RECOMMENDED**

1xx - 2xx = Scooter Pads  
5xx - 9xx = Street, Off Road & Racing Pads  
2xxx = Brake Shoes



**BRIXTON**

125 Haycroft	15 - 18	814 HF	638 HF
125 Rayburn	15 - 23	814 HF	638 HF
BX 125 Cromwell	15 - 23	814 HF	638 HF
BX 125 Cromwell ABS	19 - 23	814 HF	638 HF
BX 125 R Sunray	15 - 23	814 HF	638 HF
BX 125 R Sunray ABS	19 - 23	814 HF	638 HF
BX 125 S	15 - 23	814 HF	638 HF
BX 125 X Felsberg	15 - 23	814 HF	638 HF
BX 125 XC Felsberg	15 - 18	814 HF	638 HF
BX 150 Cromwell	15 - 23	814 HF	638 HF
BX 150 R Sunray	15 - 23	814 HF	638 HF
BX 150 S	15 - 23	814 HF	638 HF
BX 150 X Felsberg	15 - 23	814 HF	638 HF
BX 500 Crossfire	15 - 23	566 HS	675 LS
BX 500 X Crossfire	15 - 23	566 HS	675 LS
BX 500 XC Crossfire	15 - 23	706 HS	675 LS
1200 Cromwell	15 - 23	700 HS*	814 LS

**BS VILLA**

AX 50	93 - 93	111 HF	2012
GZ 50	93 - 93	111 HF	2012
ZX 50	93 - 93	115 HF	2057

**BUELL**

all models	94 - 97	658 HF	692 HF
500 Blast	01 - 09	627 HF	614 HF
XB9R 984 Firebolt	02 - 10	795 HS	614 LS
XB9S 984 Lightning	03 - 10	795 HS	614 LS
XB9SX 984 CityX	05 - 10	795 HS	614 LS
1125 CR	09 - 10	856 HS	857 LS
1125 R	08 - 10	856 HS	857 LS
M2 1200 Cyclone	98 - 02	676 HS	614 LS
RS 1200	12 - 12	658 HF	692 HF
S1 1200 Lightning	98 - 02	676 HS	614 LS
S1 1200 Whitelighting	98 - 02	676 HS	614 LS
S3 1200 Thunderbolt	98 - 02	676 HS	614 LS
X1 1200 Lightning	01 - 02	676 HS	614 LS
XB12R 1200 Firebolt	04 - 08	795 HS	614 LS
XB12R 1200 Firebolt	09 - 10	856 HS	614 LS
XB12S 1200 Lightning	04 - 08	795 HS	614 LS
XB12Scg 1200 Lightning	06 - 08	795 HS	614 LS
XB12Scg 1200 Lightning	09 - 10	856 HS	614 LS
XB12Ss 1200 Lightning Long	06 - 08	795 HS	614 LS
XB12Ss 1200 Lightning Long	09 - 10	856 HS	614 LS
XB12STT 1200 Super TT	07 - 10	795 HS	614 LS
XB12X 1200 Ulysses	06 - 10	795 HS	614 LS

**BULTACO**

50 Astro	01 - 06	148 HF	105 HF
50 Lobito	99 - 06	148 HF	105 HF

**CAGIVA**

50 AJP Caliper incl. pin/spring	90 - 19	188 HF	
50 Blues	89 - 89	108 HF	106 HF
50 City	92 - 94	115 HF	2012
50 City	95 - 97	140 HF	2012
50 City	08 - 08	111 HF	
50 Cocis	88 - 88	138 HF	106 HF
50 Cocis	89 - 89	138 HF	138 HF
50 Corsa	98 - 98	105 HF	
50 Cucciolo	97 - 99	138 HF	
50 Lucky Explorer	88 - 02	519 HF	574 HF
50 Mantis	99 - 99	105 HF	2181
50 Mito	99 - 06	103 HF	105 HF
50 Nag	08 - 08	141 HF	
50 Nuvola	00 - 00	138 HF	
50 Prima	92 - 92	519 HF	519 HF
50 Prima	93 - 94	672 HF	680 HF
50 Progress	98 - 99	105 HF	
50 Super City	93 - 95	641 HF	519 HF
50 Supercity	92 - 92	519 HF	519 HF
50 W 4	92 - 92	519 HF	519 HF



**RECOMMENDED**

1xx - 2xx = Scooter Pads  
5xx - 9xx = Street, Off Road & Racing Pads  
2xxx = Brake Shoes



**CAGIVA**

WMX 50	89 - 89	608 HF	651 HF
80 City	93 - 95	126 HF	117 HF
80 Cocis	91 - 91	519 HF	574 HF
80 Prima	92 - 92	672 HF	680 HF
80 Super City	94 - 84	641 HF	519 HF
80 Supercity	92 - 93	519 HF	519 HF
80 W 4	92 - 92	519 HF	519 HF
LR 80	83 - 83	519 HF	
SST 80	83 - 83	519 HF	
SXT 80	83 - 83	519 HF	
110 Passing	94 - 94	611 HF	
125 Aletta Electra	83 - 86	574 HF	
125 Aletta Electra	87 - 87	519 HF	
125 Aletta Oro	85 - 85	574 HF	574 HF
125 Aletta Oro	86 - 89	519 HF*	519 HF
125 Blues	87 - 85	588 HF	519 HF
125 Blues	93 - 93	519 HF	519 HF
125 Brillo	08 - 08	723 HF	
125 Cross	86 - 86	608 SI	692 SI
125 Cruiser	88 - 88	594 HF	519 HF
125 Cruiser	89 - 89	608 HF	574 HF
125 Cucciolo	00 - 01	138 CT	
125 Dakar	86 - 86	519 HF	
125 E2	86 - 86	574 HF	
125 Elefant	81 - 88	574 HF	
125 Elefantre	87 - 88	519 HF	
125 Enduro	86 - 86	519 HF	
125 Freccia	89 - 89	608 HF	519 HF
125 Freccia C 12 R	91 - 91	641 HF	519 HF
125 Mito	91 - 92	641 HF	519 HF
125 Mito	93 - 07	566 HF	519 HF
125 Nuvola	00 - 00	138 CT	
125 Planet	97 - 07	566 HF	519 HF
125 Raptor	03 - 10	566 HF	519 HF
125 Roadster	94 - 97	588 HF	
125 SST	81 - 81	574 HF	
125 Stella	97 - 08	103 CT	
125 Supercity	92 - 00	608 HF	519 HF
125 Tamanaco	87 - 92	608 HF	574 HF
125 W 8	92 - 95	519 HF	519 HF
125 W 8	96 - 01	641 HF	692 HF
125 WSTX Aletta Rossa	83 - 84	574 HF	
K7 125	91 - 94	641 HF	519 HF
N1 125	96 - 99	641 HF	519 HF
N90 125	91 - 98	641 HF	574 HF
WMX 125	88 - 88	608 SI	
WMX 125	89 - 90	692 SI	692 SI
WMX 125 GP-Replica	86 - 89	519 SI	
WRX 125	85 - 85	519 HF	
200 Aletta Electra	83 - 83	574 HF	
200 Cross	83 - 86	574 HF	
200 Elefant	86 - 86	519 HF	
200 Roadster	96 - 01	588 HF	
250 Cross	86 - 86	608 SI	
MXR 250	82 - 82	519 HF	
SST 250 Ala Verde	81 - 82	519 HF	
WMX 250	89 - 90	608 SI	692 SI
WMX 250 GP	82 - 82	519 SI	
350 Alazzurra	85 - 87	519 HF*	519 HF
350 Elefant	86 - 89	594 HF	519 HF
350 W 12	92 - 95	641 HF	519 HF
SST 350	83 - 83	519 HF	
SST 350 Ala Verde	81 - 82	519 HF	
SXT 350 Ala Rosa	82 - 82	519 HF	
T4 350 E	87 - 91	519 HF	
T4 350 R	87 - 99	519 HF	2026
MXR 400	82 - 82	519 HF	
500 Canyon	99 - 01	647 HS	638 LS
500 Mito	07 - 07	566 HS	519 LS
500 River	00 - 01	566 HF	519 HF
MXR 500	82 - 82	519 HF	
T4 500 E	87 - 90	519 HF	2026

\* = 2 sets required / 2 jeux pour l'Avant.

Full compound selection, see under "Brake pad 1:1 Drawings" / Sélection complète de composés, voir "1:1 Schémas Plaquettes de frein".

**RECOMMENDED**

1xx - 2xx = Scooter Pads  
5xx - 9xx = Street, Off Road & Racing Pads  
2xxx = Brake Shoes



CAGIVA					
WMX	500	85 - 86	519 SI		
WMX	500 Cross	87 - 87	519 SI	519 SI	
SP	525 Mito	08 - 10	566 HS	519 LS	
	600 Canyon	95 - 99	611 HS	638 LS	
	600 River	94 - 99	566 HF	519 HF	
	600 W 16	95 - 97	641 HF	692 HF	
	650 Alazzurra	84 - 84	519 HF	519 HF	
	650 Alazzurra	85 - 88	560 HF*	560 HF	
	650 Elefant	86 - 87	594 HF	519 HF	
	650 Raptor	01 - 08	706 HS*	730 LS	
	650 V-Raptor	01 - 08	706 HS*	730 LS	
	750 Elefant	88 - 88	519 HF	519 HF	
	750 Elefant	93 - 95	647 HS	671 LS	
	750 Elefant Bifaro	90 - 90	594 HF	641 HF	
	750 Lucky Explorer	88 - 88	594 HF	519 HF	
	900 Canyon I.E.	97 - 97	647 HS	638 LS	
	900 Elefant	93 - 97	671 HF*	671 HF	
	900 Elefant I.E.	91 - 92	647 HS	638 LS	
	900 Gran Canyon	99 - 04	627 HS*	638 LS	
	1000 Navigator, T	00 - 05	627 HS*	638 LS	
	1000 Raptor	00 - 08	706 HS*	730 LS	
	1000 V-Raptor	00 - 08	706 HS*	730 LS	
	1000 X3 Raptor	04 - 04	762 HS*	730 LS	
	1000 X-Raptor	03 - 04	762 HS*	730 LS	
	1000 Xtra Raptor	02 - 06	706 HS*	730 LS	
CAN-AM					
DS	50	07 - 11	2048*	2041	
DS	70	08 - 14	2048*	2041	
DS	90	07 - 18	2048*	2041	
DS	90 X	08 - 18	544 SI*	544 SI	
	200 ASE	86 - 86	519 SI		
	250 ASE	86 - 86	519 SI		
	250 MX LC	86 - 86	519 SI		
DS	250	08 - 18	810 SI*	810 SI	
	350 ASE	86 - 86	519 SI		
	400 Outlander Efi Left	09 - 14	754 SI	754 SI	
	400 Outlander Efi Right	09 - 14	767 SI		
	400 Outlander MAX STD Left	07 - 13	754 SI	754 SI	
	400 Outlander MAX STD Right	07 - 13	767 SI		
	400 Outlander MAX XT Left	07 - 13	754 SI	754 SI	
	400 Outlander MAX XT Right	07 - 13	767 SI		
	400 Outlander STD Left	07 - 14	754 SI	754 SI	
	400 Outlander STD Right	07 - 14	767 SI		
	400 Outlander XT Left	07 - 14	754 SI	754 SI	
	400 Outlander XT Right	07 - 14	767 SI		
	406 ASE	87 - 87	519 SI		
	427 Defender HD5 Left	18 - 18	957 PSI	1001 PSI	
	427 Defender HD5 Right	18 - 18	956 PSI	1002 PSI	
	427 Traxter HD5 Left	18 - 18	957 PSI	1001 PSI	
	427 Traxter HD5 Right	18 - 18	956 PSI	1002 PSI	
	450 Outlander Left	15 - 23	911 SI		
	450 Outlander MAX Left	15 - 23	911 SI		
	450 Outlander MAX Right	15 - 23	910 SI	910 SI	
	450 Outlander Right	15 - 23	910 SI	910 SI	
DS	450	08 - 12	907 SI*	908 SI	
	500 ASE	86 - 86	519 SI		
	500 MX	86 - 86	519 SI		
	500 Outlander Left	13 - 16	911 SI		
	500 Outlander MAX Left	13 - 16	911 SI		
	500 Outlander MAX Right	13 - 16	910 SI	910 SI	
	500 Outlander MAX STD Left	07 - 12	754 SI	754 SI	
	500 Outlander MAX STD Right	07 - 12	767 SI		
	500 Outlander MAX XT Left	07 - 12	754 SI	754 SI	
	500 Outlander MAX XT Right	07 - 12	767 SI		
	500 Outlander Right	13 - 16	910 SI	910 SI	
	500 Outlander STD Left	07 - 12	754 SI	754 SI	
	500 Outlander STD Right	07 - 12	767 SI		
	500 Outlander XT Left	07 - 12	754 SI	754 SI	
	500 Outlander XT Right	07 - 12	767 SI		
	500 Renegade Left	08 - 11	754 SI	754 SI	
	500 Renegade Left	13 - 15	911 SI	911 SI	

**RECOMMENDED**

1xx - 2xx = Scooter Pads  
5xx - 9xx = Street, Off Road & Racing Pads  
2xxx = Brake Shoes



CAN-AM					
	500 Renegade Right	08 - 11	767 SI		
	500 Renegade Right	13 - 15	910 SI	910 SI	
	560 Sonic	86 - 14	519 SI		
	600 Ryker Left	19 - 23	638 PSI	767 PSI	
	600 Ryker Right	19 - 23	611 PSI		
	650 Defender HD7 Left	22 - 23	957 PSI	1001 PSI	
	650 Defender HD7 Right	22 - 23	956 PSI	1002 PSI	
	650 Outlander Left	13 - 22	911 SI		
	650 Outlander MAX Left	13 - 22	911 SI		
	650 Outlander MAX Right	13 - 22	910 SI	910 SI	
	650 Outlander MAX STD Left	07 - 12	754 SI	754 SI	
	650 Outlander MAX STD Right	07 - 12	767 SI		
	650 Outlander MAX XT Left	07 - 12	754 SI	754 SI	
	650 Outlander MAX XT Right	07 - 12	767 SI		
	650 Outlander Right	13 - 22	910 SI	910 SI	
	650 Outlander STD Left	07 - 12	754 SI	754 SI	
	650 Outlander STD Right	07 - 12	767 SI		
	650 Outlander XT Left	07 - 12	754 SI	754 SI	
	650 Outlander XT Right	07 - 12	767 SI		
	650 Traxter HD7 Left	23 - 23	957 PSI	1001 PSI	
	650 Traxter HD7 Right	23 - 23	956 PSI	1002 PSI	
	650 Traxter T HD7 Left	22 - 22	957 PSI	1001 PSI	
	650 Traxter T HD7 Right	22 - 22	956 PSI	1002 PSI	
	700 Maverick Trail Left	22 - 23	957 PSI	957 PSI	
	700 Maverick Trail Right	22 - 23	956 PSI	956 PSI	
	800 Commander Left	11 - 14	638 SI	611 SI	
	800 Commander MAX R EFI Left	18 - 20	971 PSI	754 PSI	
	800 Commander MAX R EFI Right	18 - 20	972 PSI		
	800 Commander R EFI Left	18 - 18	971 PSI	754 PSI	
	800 Commander R EFI Right	18 - 18	972 PSI		
	800 Commander Right	11 - 14	611 SI		
	800 Defender HD8 Left	17 - 21	957 PSI	1001 PSI	
	800 Defender HD8 Right	17 - 21	956 PSI	1002 PSI	
	800 Maverick Trail Left	18 - 21	957 PSI	957 PSI	
	800 Maverick Trail Right	18 - 21	956 PSI	956 PSI	
	800 Outlander Left	12 - 15	911 SI		
	800 Outlander MAX Left	13 - 14	911 SI		
	800 Outlander MAX LTD Left	07 - 11	754 SI	754 SI	
	800 Outlander MAX LTD Right	07 - 11	767 SI		
	800 Outlander MAX Right	13 - 14	910 SI	910 SI	
	800 Outlander MAX STD Left	07 - 11	754 SI	754 SI	
	800 Outlander MAX STD Right	07 - 11	767 SI		
	800 Outlander MAX XT Left	07 - 11	754 SI	754 SI	
	800 Outlander MAX XT Right	07 - 11	767 SI		
	800 Outlander Right	12 - 15	910 SI	910 SI	
	800 Outlander STD Left	07 - 11	754 SI	754 SI	
	800 Outlander STD Right	07 - 11	767 SI		
	800 Outlander XT Left	07 - 11	754 SI	754 SI	
	800 Outlander XT Right	07 - 11	767 SI		
	800 Renegade Efi Left	07 - 11	754 SI	754 SI	
	800 Renegade Efi Right	07 - 11	767 SI		
	800 Renegade Left	08 - 11	754 SI	754 SI	
	800 Renegade Left	12 - 15	911 SI	911 SI	
	800 Renegade Right	08 - 11	767 SI		
	800 Renegade Right	12 - 15	910 SI	910 SI	
	800 Renegade X Left	08 - 11	754 SI	754 SI	
	800 Renegade X Right	08 - 11	767 SI		
	800 Traxter HD8 Left	16 - 21	957 PSI	1001 PSI	
	800 Traxter HD8 Right	16 - 21	956 PSI	1002 PSI	
	800 Traxter T HD8 Left	18 - 21	957 PSI	1001 PSI	
	800 Traxter T HD8 Right	18 - 21	956 PSI	1002 PSI	
	900 Ryker Left	19 - 23	638 PSI	767 PSI	
	900 Ryker Rally Left	19 - 23	638 PSI	767 PSI	
	900 Ryker Rally Right	19 - 23	611 PSI		
	900 Ryker Right	19 - 23	611 PSI		
	900 Ryker S Left	19 - 23	638 PSI	767 PSI	
	900 Ryker S Right	19 - 23	611 PSI		
	900 X3 Left	17 - 23	957 PSI	957 PSI	
	900 X3 MAX Left	17 - 23	957 PSI	957 PSI	
	900 X3 MAX Right	17 - 23	956 PSI	956 PSI	
	900 X3 MAX Turbo Left	18 - 23	957 PSI	957 PSI	
	900 X3 MAX Turbo R Left	18 - 23	957 PSI	957 PSI	

\* = 2 sets required / 2 jeux pour l'Avant.

Full compound selection, see under "Brake pad 1:1 Drawings" / Sélection complète de composés, voir "1:1 Schémas Plaquettes de frein".





**RECOMMENDED**

1xx - 2xx = Scooter Pads  
 5xx - 9xx = Street, Off Road & Racing Pads  
 2xxx = Brake Shoes



**CAN-AM**

900 X3 MAX Turbo R Right	18 - 23	956 PSI	956 PSI
900 X3 MAX Turbo Right	18 - 23	956 PSI	956 PSI
900 X3 Right	17 - 23	956 PSI	956 PSI
900 X3 Turbo Left	18 - 23	957 PSI	957 PSI
900 X3 Turbo R Left	18 - 23	957 PSI	957 PSI
900 X3 Turbo R Right	18 - 23	956 PSI	956 PSI
900 X3 Turbo Right	18 - 23	956 PSI	956 PSI
976 Defender HD10 Left	17 - 23	957 PSI	1001 PSI
976 Defender HD10 Right	17 - 23	956 PSI	1002 PSI
976 Defender HD9 Left	22 - 23	957 PSI	1001 PSI
976 Defender HD9 Right	22 - 23	956 PSI	1002 PSI
976 Traxter HD10 Left	17 - 23	957 PSI	1001 PSI
976 Traxter HD10 Right	17 - 23	956 PSI	1002 PSI
976 Traxter HD9 Left	22 - 23	957 PSI	1001 PSI
976 Traxter HD9 Right	22 - 23	956 PSI	1002 PSI
976 Traxter T HD10 Left	18 - 22	957 PSI	1001 PSI
976 Traxter T HD10 Right	18 - 22	956 PSI	1002 PSI
976 Traxter T HD9 Left	22 - 23	957 PSI	1001 PSI
976 Traxter T HD9 Right	22 - 23	956 PSI	1002 PSI
1000 Commander Left	16 - 17	971 PSI	754 PSI
1000 Commander Right	16 - 17	972 PSI	
1000 Commander MAX Left	14 - 17	971 PSI	754 PSI
1000 Commander MAX Right	14 - 17	972 PSI	
1000 Commander MAX R EFI Left	18 - 19	971 PSI	754 PSI
1000 Commander MAX R EFI Right	18 - 19	972 PSI	
1000 Commander R EFI Left	18 - 20	971 PSI	754 PSI
1000 Commander R EFI Right	18 - 20	972 PSI	
1000 Maverick Left	14 - 18	971 PSI	754 PSI
1000 Maverick Right	14 - 18	972 PSI	
1000 Maverick Left	19 - 23	957 PSI	957 PSI
1000 Maverick Right	19 - 23	956 PSI	956 PSI
1000 Maverick MAX Left	14 - 18	971 PSI	754 PSI
1000 Maverick MAX Right	14 - 18	972 PSI	
1000 Maverick MAX Left	19 - 23	957 PSI	957 PSI
1000 Maverick MAX Right	19 - 23	956 PSI	956 PSI
1000 Maverick Sport Left	18 - 23	957 PSI	957 PSI
1000 Maverick Sport Right	18 - 23	956 PSI	956 PSI
1000 Maverick Trail Left	18 - 23	957 PSI	957 PSI
1000 Maverick Trail Right	18 - 23	956 PSI	956 PSI
1000 Outlander Left	13 - 23	910 SI	910 SI
1000 Outlander Right	13 - 23	911 SI	
1000 Outlander MAX Left	13 - 23	911 SI	
1000 Outlander MAX Right	13 - 23	910 SI	910 SI
1000 Renegade Left	12 - 19	911 SI	911 SI
1000 Renegade Right	12 - 19	910 SI	910 SI
1000 Renegade Left	20 - 23	911 SI	
1000 Renegade Right	20 - 23	910 SI	910 SI
1330 Spyder F3	15 - 22	900 HS*	948 HS
1330 Spyder F3 Limited	16 - 22	900 HS*	948 HS
1330 Spyder F3-S	15 - 22	900 HS*	948 HS
1330 Spyder F3-T	16 - 22	900 HS*	948 HS
1330 Spyder RS	14 - 16	900 HS*	948 HS
1330 Spyder RS RSS	13 - 13	900 HS*	948 HS
1330 Spyder RSS	14 - 15	900 HS*	948 HS
1330 Spyder RSS Special Series	15 - 15	900 HS*	948 HS
1330 Spyder RT	14 - 22	900 HS*	948 HS
1330 Spyder RT Limited	13 - 22	900 HS*	948 HS
1330 Spyder RT RTS	13 - 13	900 HS*	948 HS
1330 Spyder RTS	14 - 15	900 HS*	948 HS
1330 Spyder RTS Special Series	15 - 15	900 HS*	948 HS
1330 Spyder ST	14 - 16	900 HS*	948 HS
1330 Spyder ST Limited	13 - 15	900 HS*	948 HS
1330 Spyder ST STS	13 - 13	900 HS*	948 HS
1330 Spyder STS	14 - 15	900 HS*	948 HS
1330 Spyder STS Special Series	15 - 15	900 HS*	948 HS

**CANNONDALE**

MX 400	00 - 03	694 RSI	632 RSI
440 Blaze Left	03 - 03	754 SI	754 SI
440 Blaze Right	03 - 03	767 SI	
440 Cannibal Left	03 - 03	754 SI	754 SI
440 Cannibal Right	03 - 03	767 SI	



**RECOMMENDED**

1xx - 2xx = Scooter Pads  
 5xx - 9xx = Street, Off Road & Racing Pads  
 2xxx = Brake Shoes



**CANNONDALE**

440 Glamis Left	03 - 03	754 SI	754 SI
440 Glamis Right	03 - 03	767 SI	
440 Moto Left	03 - 03	754 SI	754 SI
440 Moto Right	03 - 03	767 SI	
440 Speed Left	03 - 03	754 SI	754 SI
440 Speed Right	03 - 03	767 SI	
C 440 R	03 - 03	694 RSI	632 RSI
E 440 ,A, R	03 - 03	694 RSI	632 RSI
S 440	03 - 03	566 HF	632 HF
X 440	03 - 03	694 RSI	632 RSI

**CASAL**

RZ 50	82 - 82	532 HF	
-------	---------	--------	--

**CCM**

450 MX	08 - 10	671 RSI	790 RSI
GP 450	16 - 16	671 SI	675 SI
604 600 RS	01 - 01	671 HF	675 HF
604E 600 Sport	99 - 01	671 SI	675 SI
604E 600 Supermoto	99 - 01	671 SI	675 SI
C25 600	96 - 98	671 SI	675 SI
644 DS	03 - 06	671 HF	675 HF
644 R30	02 - 06	671 HF	675 HF

**CECTEK**

500 EFI Gladiator	09 - 13	810 HF*	544 HF
500 EFI King Cobra	09 - 13	878 HF*	544 HF
500 EFI Quadrift	09 - 11	878 HF*	544 HF
500 i Estoc	10 - 10	878 HF*	544 HF

**CF MOTO**

AE8	22 - 23	671 HS	
125 NK	24 - 24	706 HS	730 LS
125 Papio	17 - 17	688 HF	784 HF
400 C-Force	18 - 21	986 PSI*	799 SI
400 NK Efi	17 - 17	674 HS*	675 LS
400 SR S	24 - 24	900 HS	730 LS
450 C-Force L	16 - 17	914 SI*	799 SI
450 CL-C	24 - 24	706 HS	915 HF
450 G-Force L	16 - 17	914 SI*	799 SI
450 MT	24 - 24	706 HS	675 LS
450 NK	24 - 24	706 HS	915 HF
SR 450	23 - 23	900 HS	915 HF
500 C-Force HO	18 - 18	986 PSI*	799 SI
500 C-Force S	18 - 21	986 PSI*	799 SI
500 U-Force	18 - 20	986 PSI*	987 PSI
500 Z-Force	18 - 21	986 PSI*	987 PSI
CF 500 Terralander	13 - 15	914 SI*	799 SI
520 C-Force L	16 - 23	986 PSI*	987 PSI
520 C-Force S	16 - 21	986 PSI*	987 PSI
550 C-Force	16 - 17	914 SI*	799 SI
550 U-Force Left	15 - 16	638 SI	
550 U-Force Right	15 - 16	611 SI	
550 Z-Force Left	15 - 16	638 SI	
550 Z-Force Right	15 - 16	611 SI	
600 C-Force	19 - 19	986 PSI*	799 SI
600 C-Force	20 - 21	986 PSI*	987 PSI
600 C-Force Touring	20 - 21	986 PSI*	987 PSI
CF 625 Terralander	11 - 15	914 SI*	799 SI
650 MT	19 - 22	674 HS*	675 LS
650 NK	14 - 16	674 HS*	675 LS
650 NK Efi	17 - 17	674 HS*	675 LS
650 TK	14 - 15	674 HS*	675 LS
700 CL-X Adventure	24 - 24	706 HS	671 LS
700 CL-X Heritage	22 - 22	706 HS*	671 LS
700 CL-X Spirit	24 - 24	841 HS*	730 LS
700 CL-X Sport	22 - 22	841 HS*	730 LS
700 MT	24 - 24	674 HS*	675 LS
800 MT Explore	24 - 24	706 HS*	671 LS
800 MT Sport	22 - 22	706 HS*	671 LS
800 MT Touring	22 - 22	706 HS*	671 LS
800 NK	24 - 24	706 HS*	671 LS

\* = 2 sets required / 2 jeux pour l'Avant.

Full compound selection, see under "Brake pad 1:1 Drawings" / Sélection complète de composés, voir "1:1 Schémas Plaquettes de frein".

**RECOMMENDED**1xx - 2xx = Scooter Pads  
5xx - 9xx = Street, Off Road & Racing Pads  
2xxx = Brake Shoes

CF MOTO				
	800 NK GP	24 - 24	841 HS*	730 LS
	800 U-Force	18 - 21	986 PSI*	987 PSI
	800 Z-Force EX Left	15 - 15	638 SI	
	800 Z-Force EX Right	15 - 15	611 SI	
	800 Z-Force EX	18 - 21	986 PSI*	987 PSI
	800 Z-Force Trail	18 - 21	986 PSI*	987 PSI
CF	800 Terralander	12 - 14	914 SI*	799 SI
	1000 Z-Force	18 - 19	986 PSI*	987 PSI
CF MOTO ZEEHO				
	AE8	22 - 23	671 HS	730 LS
CIMATTI				
	50 Gringo	85 - 85	532 HF	
COBRA				
CX	50 Big Wheel	10 - 14	794 RSI	794 RSI
CX	50 Junior	07 - 10	794 RSI	
CX	50 Junior	11 - 13	794 RSI	794 RSI
CX	50 Senior	07 - 13	794 RSI	794 RSI
COLOVE				
	322 321RR	23 - 23	900 HS	926 HF
CPI				
	50 Aragon Club	07 - 09	141 HF	
	50 Aragon GP	06 - 09	141 HF	
	50 Aragon SP	07 - 09	141 HF	
	50 Baby	02 - 02	101 HF	2028
	50 Freaky	07 - 07	141 HF	
	50 GTR	02 - 02	120 HF	
	50 GTR	03 - 09	157 HF	123 HF
	50 GTS	02 - 03	120 HF	145 HF
	50 Hussar	01 - 02	101 HF	2028
	50 Hussar	03 - 06	141 HF	2028
	50 Mars	01 - 02	101 HF	2028
	50 Oliver	03 - 12	141 HF	2028
	50 Oliver City	03 - 12	141 HF	2028
	50 Oliver Sport	03 - 12	141 HF	2028
	50 Popcorn	01 - 02	101 HF	2028
	50 Popcorn	03 - 06	141 HF	2032
	50 Supermoto, Supercross	03 - 09	105 HF	105 HF
	125 Aragon GP	07 - 12	141 CT	
	125 GTR, GTS	02 - 03	120 CT	143 CT
	125 Sahel	02 - 02	694 HF	604 HF
	125 Supermoto	07 - 12	559 HF	
	125 X-Large	02 - 03	157 CT*	157 CT
	200 GTR, GTS	02 - 03	120 CT	143 CT
	200 X-Large	02 - 03	157 CT*	157 CT
	250 XS ATV	07 - 08	810 SI*	
XS	250 Quad	06 - 08	544 SI*	848 SI
CZ				
CZ	180	93 - 93	506 HF	
DAELIM				
	50 a Four	06 - 12	163 HF	
	50 Besbi	07 - 07	121 HF	
	50 Bonita	09 - 12	115 HF	
	50 Delfino	99 - 99	100 HF	2069
	50 E-Five	03 - 08	100 HF	
	50 History, S-Five	01 - 01	100 HF	100 HF
	50 Message II	02 - 02	100 HF	
	50 Tapo	99 - 04	100 HF	2069
	50 Vivo	99 - 99	100 HF	2069
GZ	50 G Message	98 - 01	115 HF	
SE	50 Cordi	06 - 12	100 HF	
SJ	50 S-Five	06 - 12	115 HF	
	100 Altino	99 - 03	536 HF	
	100 Delfino	99 - 04	100 HF	2069
	110 City Ace	03 - 07	103 HF	
	125 Altino	02 - 04	100 CT	

**RECOMMENDED**1xx - 2xx = Scooter Pads  
5xx - 9xx = Street, Off Road & Racing Pads  
2xxx = Brake Shoes

DAELIM				
	125 Delfino	08 - 11	163 CT	
	125 DLX, Otello DLX	01 - 02	100 CT	100 CT
	125 History	01 - 06	100 CT	100 CT
	125 Message II	00 - 00	100 CT	
	125 Otello	99 - 00	100 CT	
	125 Otello	08 - 08	146 CT	100 CT
	125 Roadwin	04 - 12	700 HF	688 HF
	125 Rocket	99 - 01	700 HF	2069
	125 S2	06 - 08	183 CT	100 CT
	125 S2 FI	07 - 15	146 CT	100 CT
NF	125	03 - 03	536 HF	
NS	125 II	00 - 00	100 CT	2069
QL	125 Steezer	17 - 19	146 CT	119 CT
S	125 from VIN SDC007441	17 - 19	146 CT	201 CT
S	125 to VIN SDC007440	17 - 19	146 CT	119 CT
SC	125 Besbi	08 - 13	144 CT	
SL	125 U3 FI	07 - 09	146 CT	100 CT
SV	125 S3	11 - 15	146 CT	119 CT
VL	125 Daystar	00 - 12	700 HF	
VS	125 , Evolution	95 - 08	536 HF	
VT	125 Evolution	00 - 03	700 HF	2069
VT	125 Magna	97 - 99	700 HF	
	250 Roadwin	08 - 12	700 HF	688 HF
	250 S2	06 - 10	183 CT	100 CT
ST	250 Sector Quad	05 - 06	544 SI*	847 SI
S	300	17 - 19	146 MS	201 MS
DAVINCI				
	DC100	22 - 23	948 HS	
DAYTONA				
DY	125 RS Efi	17 - 21	235 CT	134 CT
DB MOTORS				
ZZ	50 Pirat	00 - 05	519 HF	519 HF
ZZ	50 Sport	00 - 05	519 HF	
DERBI				
	50 AJP Caliper incl. pin/spring	90 - 19	188 HF	
	50 Atlantis	99 - 08	105 HF	2181
	50 Atlantis 4T	04 - 10	105 HF	
	50 Atlantis Bullet	04 - 05	105 HF	
	50 Atlantis H2O	01 - 01	105 HF	
	50 Atlantis H2O Wave	01 - 01	105 HF	
	50 Atlantis Wave	01 - 02	105 HF	
	50 Aventura	96 - 96	105 HF	2206
	50 Black Devil	04 - 04	168 HF	105 HF
	50 Boulevard	09 - 13	177 HF	
	50 DRD Pro corse	06 - 08	189 MS	105 HF
	50 DRD Racing R	05 - 10	168 HF	105 HF
	50 DRD Racing R Ltd.	05 - 05	168 HF	105 HF
	50 DRD Racing SM	05 - 05	168 HF	105 HF
	50 DRD Racing SM Ltd.	05 - 05	168 HF	105 HF
	50 Easy	96 - 98	138 HF	2181
	50 Fenix	94 - 07	105 HF	105 HF
	50 Furax	96 - 98	105 HF	105 HF
	50 Hunter	97 - 99	105 HF	2181
	50 Manhattan	99 - 99	105 HF	2181
	50 Predator LC	99 - 02	105 HF	105 HF
	50 Predator O2	00 - 02	105 HF	105 HF
	50 Rambla	06 - 06	105 HF	105 HF
	50 Savannah	91 - 97	105 HF	
	50 Senda DRD Pro SM	05 - 11	157 HF	167 HF
	50 Senda L	99 - 01	105 HF	105 HF
	50 Senda R DRD	03 - 04	148 HF*	105 HF
	50 Senda R, X-Treme	94 - 04	105 HF	105 HF
	50 Senda SM DRD	03 - 04	105 HF*	105 HF
	50 Senda SM DRD Black Edition	03 - 04	168 HF	105 HF
	50 Senda SM, X-Treme	99 - 06	105 HF	105 HF
	50 Sonar	10 - 11	142 HF	
	50 Stinger	96 - 96	105 HF	
	50 Vamos FL	95 - 99	105 HF	2181

\* = 2 sets required / 2 jeux pour l'Avant.

Full compound selection, see under "Brake pad 1:1 Drawings" / Sélection complète de composés, voir "1:1 Schémas Plaquettes de frein".





**RECOMMENDED**

1xx - 2xx = Scooter Pads  
 5xx - 9xx = Street, Off Road & Racing Pads  
 2xxx = Brake Shoes



DERBI				
	50 Vamos L	95 - 95	105 HF	2181
	50 Vamos R (A.J.P. cal.)	95 - 95	105 HF	2206
	50 Vamos R (Brembo cal.)	95 - 95	123 HF	2206
	50 Variant Sport-R	01 - 13	105 HF	2206
	50 X-Race R	05 - 09	105 HF	105 HF
	50 X-Treme R	05 - 05	105 HF	105 HF
DS	50	88 - 88	559 HF	
FD	50 Yumbo	84 - 84	559 HF	
FD	50 Yumbo Extra	87 - 87	559 HF	
FDS	50	87 - 87	559 HF	
FDT	50	87 - 87	559 HF	
FDT	50 Coppa	85 - 85	559 HF	
FDX	50	89 - 89	559 HF	
GP	50	01 - 01	105 HF	
GP1	50	01 - 03	105 HF	105 HF
GP1	50	05 - 05	157 HF	105 HF
GPR	50 Nude	04 - 10	730 HF	559 HF
GPR	50 R	98 - 03	148 HF	105 HF
GPR	50 Racing	04 - 13	730 HF	559 HF
GPX1	50	06 - 06	189 MS	105 HF
ST	50 Paddock	96 - 99	105 HF	2181
	75 GPR	89 - 89	607 HF	559 HF
	75 Sport, Coppa	84 - 84	559 HF	
GPR	75 Sport	92 - 92	607 HF	559 HF
GPR	80 Cup	04 - 05	821 HS	559 HF*
	100 Atlantis 4T	04 - 06	105 HF	
	100 Atlantis 02/H20	01 - 01	105 HF	
	125 Atmosphere	99 - 99	148 CT	
	125 Boulevard	03 - 07	167 CT	2205
	125 Mulhacen	07 - 07	774 HF	519 HF
	125 Mulhacen	08 - 11	859 HF	585 HF
	125 Predator	99 - 99	105 CT	
	125 Rambla	08 - 14	108 CT	152 CT
	125 Senda Baja	06 - 12	168 HF	167 CT
	125 Senda DRD SM	10 - 14	157 HF	203 HF
	125 Senda R 4T	04 - 12	774 HF	559 HF
	125 Senda X-Treme SM 4T	04 - 05	774 HF	559 HF
	125 Terra	07 - 07	559 HF	519 HF
	125 Terra	08 - 13	859 HF	585 HF
	125 Terra Adventure	08 - 14	859 HF	585 HF
GP1	125	05 - 06	730 HF	559 HF
GPR	125	05 - 06	821 HS	559 HF*
GPR	125 Nude	05 - 08	821 HS	559 HF*
GPR	125 Racing	09 - 09	821 HS	559 HF*
	150 Boulevard	03 - 09	167 CT	2205
	180 Predator	99 - 99	148 CT	
DXR	200 Quad (Front disc)	04 - 07	544 Si*	586 Si
DXR	200 Quad (Front drum)	04 - 05	2028	586 Si
DXR	200 Quad (Front drum)	04 - 05	2028	611 Si
	250 RC	85 - 85	519 HF	
DXR	250 Quad (Front disc)	04 - 07	544 Si*	586 Si
DXR	250 Quad (Front drum)	04 - 05	2028	586 Si
DXR	250 Quad (Front drum)	04 - 05	2028	611 Si
GP1	250	05 - 09	730 HF	772 HF
	300 Rambla	08 - 12	108 MS	152 MS
	659 Mulhacen	05 - 05	788 HS	730 LS
	659 Mulhacen	06 - 07	762 HS	730 LS
	659 Mulhacen Cafe	08 - 08	762 HS	730 LS
<b>DUCATI</b>				
	250 Desmo	70 - 77	506 HF	
	350	75 - 78	519 HF	
	350 Desmo	70 - 77	506 HF	
	350 F3	86 - 90	506 HF*	506 HF
	350 GTV	77 - 77	519 HF	519 HF
	350 Indiana	86 - 91	594 HF	519 HF
	350 Paso	86 - 86	519 HF*	519 HF
	350 Sport	77 - 80	519 HF*	519 HF
	400 Monster (Japan)	01 - 06	706 HS	519 LS
	400 Scrambler Sixty Two	16 - 20	674 HS	675 LS
	400 SS, Junior	92 - 97	566 HF*	519 HF
	400 SS, Nuda	92 - 96	566 HF	519 HF



**RECOMMENDED**

1xx - 2xx = Scooter Pads  
 5xx - 9xx = Street, Off Road & Racing Pads  
 2xxx = Brake Shoes



DUCATI				
	500 GTV	77 - 82	519 HF*	519 HF
	500 Pantah	85 - 89	519 HF*	519 HF
	500 Sport	77 - 82	506 HF*	506 HF
	500 Sport Desmo	77 - 82	519 HF*	
	500 Twin GTL	75 - 80	519 HF	
	502 Single	93 - 93	566 HF*	519 HF
	502 Supermono	93 - 93	566 HF*	519 HF
	600 Monster	00 - 01	706 HS	519 LS
	600 Pantah TL, SL	78 - 89	506 HF*	506 HF
	600 SL, TL Pantah	76 - 89	506 HF*	519 HF
	600 SS Supersport	95 - 00	566 HF	519 HF
M	600 Monster	94 - 99	566 HF	519 HF
	620 Monster Dark i.e.	02 - 06	706 HS	519 LS
	620 Monster i.e., s i.e.	02 - 06	706 HS*	519 LS
	620 Multistrada	05 - 06	671 HS*	730 LS
	620 Multistrada Dark	05 - 06	706 HS	730 LS
	620 Sport	03 - 06	706 HS*	730 LS
	650 Indiana	86 - 89	594 HF	519 HF
	650 Pantah	84 - 89	506 HF*	506 HF
	695 Monster	07 - 12	671 HS*	519 LS
	696 Monster	08 - 12	706 HS*	730 LS
	698 Hypermotard Mono	24 - 24	900 HS	675 LS
	748 ,S	99 - 02	706 HS*	519 LS
	748 Biposto	95 - 98	566 HF*	519 HF
	748 R	00 - 00	706 HS*	519 LS
	748 R	01 - 02	762 HS*	519 LS
	748 SP	95 - 97	566 HF*	519 HF
	748 SPS	98 - 99	706 HS*	519 LS
	749 ,S	03 - 07	762 HS*	730 LS
	749 R	04 - 07	762 HS*	730 LS
	750 F1	86 - 98	506 HF*	506 HF
	750 GT	74 - 76	506 HF*	
	750 Indiana	85 - 86	594 HF	519 HF
	750 Monster	96 - 99	566 HF*	519 HF
	750 Monster	00 - 01	706 HS*	519 LS
	750 Monster i.e.	02 - 02	706 HS*	519 LS
	750 Paso	86 - 88	506 HF*	519 HF
	750 Sport	74 - 76	523 HF*	
	750 Sport	90 - 90	506 HS*	506 LS
	750 Sport	00 - 02	706 HS	730 LS
	750 SS	74 - 76	506 HF*	506 HF
	750 SS	91 - 98	566 HF	506 HF
	750 SS Supersport	95 - 99	566 HF	519 HF
	750 SS, Carenara	92 - 98	566 HF	519 HF
	750 SS, Nuda	92 - 92	566 HF	519 HF
	750 Super Sport	92 - 94	566 HF*	519 HF
	750 Super Sport	00 - 02	706 HS*	730 LS
	795 Monster	12 - 12	706 HS*	730 LS
	796 Hypermotard	10 - 12	706 HS*	730 LS
	796 Monster	11 - 14	706 HS*	730 LS
	796 Monster ABS	11 - 14	706 HS*	730 LS
	797 Monster	17 - 21	900 HS	675 LS
	797 Monster+	17 - 20	900 HS	675 LS
	800 Monster Dark i.e., s i.e.	03 - 07	706 HS*	519 LS
	800 Monster i.e., s i.e.	03 - 07	706 HS*	519 LS
	800 Sport	03 - 06	706 HS*	730 LS
	800 Supersport	03 - 06	706 HS*	730 LS
	803 Monster S2R	05 - 07	671 HS*	519 LS
	803 Monster S2R ABS	05 - 07	671 HS*	519 LS
	803 Scrambler	17 - 18	900 HS	675 LS
	803 Scrambler Classic	15 - 19	900 HS	675 LS
	803 Scrambler CR	17 - 20	900 HS	675 LS
	803 Scrambler CR Cafe Racer	17 - 20	900 HS	675 LS
	803 Scrambler Desert Sled	17 - 23	900 HS	675 LS
	803 Scrambler Enduro	15 - 16	900 HS	675 LS
	803 Scrambler Flat Track Pro	16 - 16	900 HS	675 LS
	803 Scrambler Full Throttle	15 - 24	900 HS	675 LS
	803 Scrambler Icon	15 - 24	900 HS	675 LS
	803 Scrambler Icon Dark	20 - 23	900 HS	675 LS
	803 Scrambler Mach 2.0	18 - 18	900 HS	675 LS
	803 Scrambler Nightshift	20 - 24	900 HS	675 LS
	803 Scrambler SCR	20 - 20	900 HS*	675 LS

\* = 2 sets required / 2 jeux pour l'Avant.

Full compound selection, see under "Brake pad 1:1 Drawings" / Sélection complète de composés, voir "1:1 Schémas Plaquettes de frein".

**RECOMMENDED**1xx - 2xx = Scooter Pads  
5xx - 9xx = Street, Off Road & Racing Pads  
2xxx = Brake Shoes

DUCATI				
	803 Scrambler Street Classic	17 - 18	900 HS	675 LS
	803 Scrambler Urban Enduro	15 - 18	900 HS	675 LS
	803 Scrambler Urban Motard	22 - 23	900 HS	675 LS
	821 Hypermotard	13 - 16	900 HS*	730 LS
	821 Hypermotard ABS	13 - 16	900 HS*	730 LS
	821 Hypermotard SP	13 - 16	900 HS*	730 LS
	821 Hypermotard SP ABS	13 - 16	900 HS*	730 LS
	821 Hyperstrada	13 - 16	900 HS*	730 LS
	821 Hyperstrada ABS	13 - 16	900 HS*	730 LS
	821 Monster	14 - 21	900 HS*	730 LS
	821 Monster Dark	15 - 16	900 HS*	730 LS
	821 Monster Stealth	19 - 21	900 HS*	730 LS
	848	08 - 10	706 HS*	730 LS
	848 EVO	11 - 12	841 HS*	730 LS
	848 Streetfighter	12 - 15	706 HS*	730 LS
	848 Streetfighter S	12 - 15	841 HS*	730 LS
	851 Strada	89 - 89	566 HF*	519 HF
	851 Strada	91 - 92	566 HF*	506 HF
	851 Superbike	90 - 90	566 HF*	519 HF
	860 GT	75 - 77	506 HF	
	860 GT	85 - 85	506 HF	506 HF
	888 Roche Replica	91 - 91	566 HF*	506 HF
	888 SP V	93 - 93	566 HF*	519 HF
	888 SP4	92 - 95	566 HF*	519 HF
	888 SPO	93 - 93	566 HF*	519 HF
	888 SPS	92 - 95	566 HF*	519 HF
	888 Strada	93 - 93	566 HF*	519 HF
	888 Superbike	93 - 93	566 HF*	519 HF
	899 Panigale	14 - 15	900 HS*	730 LS
	900 FE	97 - 98	566 HF*	519 HF
	900 GTS	77 - 79	506 HF	
	900 I. E.	90 - 93	566 HF*	519 HF
	900 M, IL Monster	93 - 99	566 HF*	519 HF
	900 Mike Hailwood Replica	85 - 86	506 HF*	506 HF
	900 Monster	00 - 01	706 HS*	519 LS
	900 Monster i.e.	02 - 02	706 HS*	519 LS
	900 Paso	89 - 89	506 HF*	519 HF
	900 S2 Desmo	85 - 85	506 HF*	506 HF
	900 SL	92 - 97	566 HF*	519 HF
	900 Sport	77 - 78	506 HF*	506 HF
	900 SS	78 - 89	506 HF*	506 HF
	900 SS	90 - 94	566 HF*	519 HF
	900 SS Supersport	95 - 97	566 HF	519 HF
	900 SSR	92 - 92	566 HF*	519 HF
	900 Super Sport	98 - 02	706 HS*	730 LS
M	900 Street Monster	94 - 99	566 HF*	519 HF
MH	900	00 - 01	706 HS*	519 LS
	916 Biposto	94 - 98	566 HF*	519 HF
	916 Monster S4	01 - 03	706 HS*	519 LS
	916 Sport Touring 4	99 - 01	706 HS*	730 LS
	916 SPS	97 - 98	706 HS*	519 LS
	937 DesertX	23 - 24	901 HS*	671 LS
	937 DesertX Rally	24 - 24	901 HS*	671 LS
	937 Monster	20 - 24	900 HS*	730 LS
	937 Monster +	20 - 24	900 HS	730 LS
	937 Monster SP	23 - 24	901 HS*	730 LS
	937 Multistrada V2	22 - 24	900 HS*	1003 LS
	937 Multistrada V2 S	22 - 24	900 HS*	1003 LS
	939 Hypermotard	16 - 18	900 HS*	730 LS
	939 Hypermotard SP	16 - 18	900 HS*	730 LS
	939 Hyperstrada	16 - 16	900 HS*	730 LS
	939 SuperSport	17 - 20	900 HS*	730 LS
	939 SuperSport S	17 - 20	900 HS*	730 LS
	944 Sport Touring	98 - 03	706 HS*	730 LS
	944 ST2	97 - 03	706 HS*	730 LS
	950 Hypermotard	19 - 24	900 HS*	730 LS
	950 Hypermotard RVE	20 - 24	900 HS*	730 LS
	950 Hypermotard SP	19 - 24	900 HS*	730 LS
	950 Multistrada	17 - 21	900 HS	1003 LS
	950 Multistrada S	19 - 21	900 HS	1003 LS
	950 Supersport	20 - 24	900 HS*	730 LS
	950 Supersport S	20 - 24	900 HS*	730 LS

**RECOMMENDED**1xx - 2xx = Scooter Pads  
5xx - 9xx = Street, Off Road & Racing Pads  
2xxx = Brake Shoes

DUCATI				
	955 Panigale V2	20 - 24	900 HS*	730 LS
	955 Panigale V2 Bayliss	22 - 24	900 HS*	730 LS
	955 Streetfighter V2	22 - 24	900 HS*	730 LS
	959 Panigale	16 - 20	900 HS*	730 LS
	959 Panigale Corse	18 - 20	900 HS*	730 LS
D16RR	990 Desmosedici RR	07 - 08	841 HS*	730 LS
	992 ST3	04 - 07	706 HS*	730 LS
	992 ST3s ABS	06 - 07	706 HS*	730 LS
	996	99 - 01	706 HS*	519 LS
	996 Monster S4R	04 - 06	706 HS*	519 LS
	996 R	01 - 01	762 HS*	519 LS
	996 RS (slipper clutch)	00 - 01	762 HS*	519 LS
	996 S	01 - 01	706 HS	519 LS
	996 ST4s	02 - 06	706 HS*	730 LS
	996 ST4s ABS	03 - 06	706 HS*	730 LS
	998	02 - 04	706 HS*	519 LS
	998 Monster S4Rs	06 - 06	762 HS*	730 LS
	998 R	02 - 04	762 HS*	519 LS
	998 RS (slipper clutch)	02 - 03	762 HS*	519 LS
	998 S	02 - 04	706 HS*	519 LS
	998 Superleggera V4	20 - 24	841 HS*	730 LS
	999	03 - 07	762 HS*	730 LS
	999 Monster S4R	07 - 08	762 HS*	730 LS
	999 Monster S4RS	07 - 08	762 HS*	730 LS
	999 R	03 - 07	762 HS*	730 LS
	999 RS (slipper clutch)	04 - 05	762 HS*	730 LS
	999 S	03 - 07	762 HS*	730 LS
	1000 /6 Mike Hailwood Replica	85 - 86	506 HF*	506 HF
	1000 Biposto	07 - 08	674 HS*	675 LS
	1000 GT	05 - 10	674 HS*	675 LS
	1000 GT Touring	09 - 10	674 HS*	675 LS
	1000 Hypermotard	06 - 06	762 HS*	730 LS
	1000 Mille Replica	84 - 85	506 HF*	506 HF
	1000 Monster Dark i.e., s i.e.	03 - 06	706 HS*	519 LS
	1000 Monster i.e., s i.e.	03 - 06	706 HS*	519 LS
	1000 Monster S2R	06 - 07	706 HS*	730 LS
	1000 Multistrada	07 - 07	706 HS*	730 LS
	1000 Multistrada DS	03 - 06	706 HS*	730 LS
	1000 Multistrada S DS	05 - 06	706 HS*	730 LS
	1000 Panigale V4 R	19 - 24	841 HS*	730 LS
	1000 Paul Smart	05 - 08	674 HS*	675 LS
	1000 S2 Desmo	85 - 85	506 HF*	506 HF
	1000 Sport	05 - 09	674 HS*	675 LS
	1000 Sport S	05 - 09	674 HS*	675 LS
	1000 Supersport DS	03 - 06	706 HS*	730 LS
	1098	07 - 08	841 HS*	730 LS
	1098 R	08 - 10	841 HS*	730 LS
	1098 R Bayliss LE	09 - 10	841 HS*	730 LS
	1098 S	07 - 08	841 HS*	730 LS
	1098 Streetfighter	09 - 14	841 HS*	730 LS
	1098 Streetfighter S	09 - 13	841 HS*	730 LS
	1100 Hypermotard	07 - 09	706 HS*	730 LS
	1100 Hypermotard EVO	10 - 12	706 HS*	730 LS
	1100 Hypermotard EVO SP	10 - 12	841 HS*	730 LS
	1100 Hypermotard S	07 - 09	841 HS*	730 LS
	1100 Monster	09 - 13	706 HS*	730 LS
	1100 Monster ABS	09 - 10	706 HS*	730 LS
	1100 Monster EVO	11 - 13	706 HS*	730 LS
	1100 Monster EVO ABS	11 - 13	706 HS*	730 LS
	1100 Monster S	09 - 13	706 HS*	730 LS
	1100 Monster S ABS	09 - 10	706 HS*	730 LS
	1100 Multistrada	07 - 09	706 HS*	730 LS
	1100 Multistrada S	07 - 09	706 HS*	730 LS
	1100 Scrambler	18 - 19	900 HS*	675 LS
	1100 Scrambler Dark Pro	20 - 24	900 HS*	675 LS
	1100 Scrambler Desert X	20 - 20	900 HS*	675 LS
	1100 Scrambler Pro	20 - 23	900 HS*	675 LS
	1100 Scrambler Special	18 - 19	900 HS*	675 LS
	1100 Scrambler Sport	18 - 19	900 HS*	675 LS
	1100 Scrambler Sport Pro	20 - 24	900 HS*	675 LS
	1100 Scrambler Tribute Pro	22 - 24	900 HS*	675 LS
	1103 Multistrada V4 RS	24 - 24	841 HS*	671 LS

\* = 2 sets required / 2 jeux pour l'Avant.

Full compound selection, see under "Brake pad 1:1 Drawings" / Sélection complète de composés, voir "1:1 Schémas Plaquettes de frein".





**RECOMMENDED**

1xx - 2xx = Scooter Pads  
 5xx - 9xx = Street, Off Road & Racing Pads  
 2xxx = Brake Shoes



**DUCATI**

1103 Panigale V4	18 - 24	841 HS*	730 LS
1103 Panigale V4 SP	21 - 21	841 HS*	730 LS
1103 Panigale V4 SP2	22 - 24	841 HS*	730 LS
1103 Panigale V4 Speciale	18 - 19	841 HS*	730 LS
1103 Panigale V4S	18 - 24	841 HS*	730 LS
1103 Panigale V4S Corse	19 - 19	841 HS*	730 LS
1103 Streetfighter V4	20 - 24	841 HS*	730 LS
1103 Streetfighter V4 Lamborghini	20 - 24	841 HS*	730 LS
1103 Streetfighter V4 SP	22 - 23	841 HS*	730 LS
1103 Streetfighter V4 SP2	23 - 24	841 HS*	730 LS
1103 Streetfighter V4S	20 - 24	841 HS*	730 LS
1158 Diavel V4	23 - 24	841 HS*	674 LS
1158 Multistrada V4	21 - 24	900 HS*	1003 LS
1158 Multistrada V4 Pikes Peak	22 - 24	841 HS*	671 LS
1158 Multistrada V4 Rally	23 - 24	841 HS*	1003 LS
1158 Multistrada V4S	21 - 24	841 HS*	1003 LS
1158 Multistrada V4S Sport	21 - 24	841 HS*	1003 LS
1198	09 - 13	841 HS*	730 LS
1198 S	09 - 12	841 HS*	730 LS
1198 SP	11 - 12	841 HS*	730 LS
1199 Panigale	12 - 14	841 HS*	730 LS
1199 Panigale R	13 - 15	841 HS*	730 LS
1199 Panigale S	12 - 14	841 HS*	730 LS
1199 Superleggera	14 - 14	841 HS*	730 LS
1200 Diavel	11 - 18	901 HS*	674 LS
1200 Diavel Carbon	14 - 23	901 HS*	674 LS
1200 Diavel Dark	14 - 23	901 HS*	674 LS
1200 Diavel Strada	11 - 14	901 HS*	674 LS
1200 Diavel Titanium	15 - 23	901 HS*	674 LS
1200 Monster	14 - 21	900 HS*	730 LS
1200 Monster 25 Anniversario	19 - 19	841 HS*	730 LS
1200 Monster R	16 - 19	841 HS*	730 LS
1200 Monster S	14 - 21	841 HS*	730 LS
1200 Monster S Stripe	15 - 17	841 HS*	730 LS
1200 Multistrada	10 - 14	706 HS*	730 LS
1200 Multistrada	15 - 16	900 HS*	671 LS
1200 Multistrada Enduro	16 - 18	900 HS*	1003 LS
1200 Multistrada Enduro Pro	18 - 18	900 HS*	1003 LS
1200 Multistrada S	15 - 17	841 HS*	671 LS
1200 Multistrada S D-air	15 - 17	841 HS*	671 LS
1200 Multistrada S GT	12 - 14	706 HS*	730 LS
1200 Multistrada S Pikes Peak	11 - 14	706 HS*	730 LS
1200 Multistrada S Pikes Peak	16 - 17	841 HS*	671 LS
1200 Multistrada S Sport	10 - 14	706 HS*	730 LS
1200 Multistrada S Touring	10 - 14	706 HS*	730 LS
1200 Multistrada S Touring ABS	15 - 16	841 HS*	671 LS
1200 Multistrada Touring ABS	10 - 14	706 HS*	730 LS
1200 Xdiavel	16 - 18	901 HS*	674 LS
1200 Xdiavel S	16 - 18	901 HS*	674 LS
1260 Diavel	19 - 22	900 HS*	674 LS
1260 Diavel Lamborghini	20 - 23	901 HS*	674 LS
1260 Diavel S	19 - 22	901 HS*	674 LS
1260 Multistrada	18 - 18	841 HS*	671 LS
1260 Multistrada Enduro	19 - 21	900 HS*	1003 LS
1260 Multistrada S	18 - 19	841 HS*	671 LS
1260 Multistrada S D-air	18 - 19	841 HS*	671 LS
1260 Multistrada S Grand Tour	20 - 20	841 HS*	671 LS
1260 Multistrada S Pikes Peak	18 - 19	841 HS*	671 LS
1262 Xdiavel	19 - 23	901 HS*	674 LS
1262 Xdiavel Black Star	20 - 23	901 HS*	674 LS
1262 Xdiavel Dark	22 - 23	901 HS*	674 LS
1262 Xdiavel Dark	24 - 24	900 HS*	674 LS
1262 Xdiavel Nera	24 - 24	901 HS*	674 LS
1262 Xdiavel S	19 - 24	901 HS*	674 LS
1299 Panigale	15 - 17	841 HS*	730 LS
1299 Panigale R	15 - 17	841 HS*	730 LS
1299 Panigale R Final Edition	17 - 20	841 HS*	730 LS
1299 Panigale S	15 - 17	841 HS*	730 LS
1299 Panigale S Anniversario	17 - 17	841 HS*	730 LS
1299 Superleggera	17 - 17	841 HS*	730 LS



**RECOMMENDED**

1xx - 2xx = Scooter Pads  
 5xx - 9xx = Street, Off Road & Racing Pads  
 2xxx = Brake Shoes



**EASY RIDER**

50 Easy Rider	99 - 99	102 HF	2028
<b>EBR</b>			
1190 RS	12 - 15	856 HS	857 LS
1190 RX	14 - 15	856 HS	857 LS
1190 SX	14 - 15	856 HS	857 LS
<b>ELSTARS</b>			
125 Blade S	10 - 11	211 HF	211 HF
<b>ENDRESS</b>			
EMR 50	95 - 95	121 HF	
<b>ENERGICA</b>			
Ego	15 - 21	901 HS*	730 LS
Eva EsseEsse9	18 - 23	901 HS*	730 LS
Eva Ribelle	15 - 21	901 HS*	730 LS
Experia	23 - 23	901 HS*	730 LS
<b>E-TON</b>			
RXL 150 Viper	07 - 07	2012*	847 SI
VXL 250 Vector, ST Vector	06 - 07	544 SI*	847 SI
VTX 300 Vortex, ST Vortex	07 - 07	544 SI*	847 SI
VXL 300 Vector, ST Vector	07 - 13	544 SI*	847 SI
<b>EXCELSIOR-HENDERSON</b>			
1386 Deadwood Special	00 - 00	739 H.HS	739 H.LS
1386 Super X all models	99 - 99	739 H.HS	739 H.LS
<b>FACTORY</b>			
50 Helix	04 - 06		544 SI
50 Rex	04 - 06		544 SI
R12 50 Phantom Agua	06 - 06	803 RSI	559 RSI
R14 50 Phantom Agua	04 - 04	803 RSI	559 RSI
R14 50 Phantom Aire	03 - 03	559 RSI	
RP 50 Desert	04 - 04	120 HF	105 HF
SM 50 Chrono	04 - 04	120 HF	105 HF
SP 50 Chrono	04 - 04	120 HF	105 HF
YR 50 Desert	04 - 04	120 HF	105 HF
R2 65 Phantom	04 - 04	803 RSI	559 RSI
100 Helix	04 - 06		544 SI
100 Rex	04 - 06		544 SI
YR 125	06 - 06	551 HF	559 HF
YR 250	99 - 03	671 SI	675 SI
<b>FANTIC</b>			
50 .1 Oasis	87 - 87	574 HF	574 HF
50 .1 Raider	87 - 87	692 HF	
50 .1 Raider Rally	87 - 87	574 HF	
50 Big Wheel	93 - 93	111 HF	118 HF
50 Caballero Motard	10 - 10	217 HF	220 HF
50 Caballero Regularita	10 - 10	217 HF	220 HF
50 Fast	88 - 88	607 HF	
50 Grinta	95 - 96	111 HF	118 HF
50 Koala	88 - 89	519 HF	519 HF
50 Koala	90 - 90	574 HF	574 HF
50 Leader	95 - 95	111 HF	118 HF
50 Oasis	90 - 90	607 HF	574 HF
50 Pony	93 - 96	2028	2028
50 Pony SR	93 - 95	111 HF	2028
50 Queenie	95 - 96	111 HF	2028
50 Regolarna Casa	08 - 09	168 HF	101 HF
50 Regolarna Competizione	08 - 09	694 HF	604 HF
50 Strada	83 - 83	692 HF	
50 Super SIX	83 - 83	532 HF	
50 Supersei Motard	08 - 09	168 HF	101 HF
50 Trial	83 - 83	595 HF	
50 Trial .5 .7 .9	89 - 91	105 HF	105 HF
MX 50 Regolarna Competizione	08 - 08	694 RSI	604 RSI
RC 50 Caballero	91 - 91	519 HF	519 HF
RS 50 Caballero	91 - 91	519 HF	519 HF
MX 65 Regolarna Competizione	08 - 08	694 RSI	604 RSI

\* = 2 sets required / 2 jeux pour l'Avant.

Full compound selection, see under "Brake pad 1:1 Drawings" / Sélection complète de composés, voir "1:1 Schémas Plaquettes de frein".

**RECOMMENDED**1xx - 2xx = Scooter Pads  
5xx - 9xx = Street, Off Road & Racing Pads  
2xxx = Brake Shoes

FANTIC				
	75 Oasis	89 - 89	607 HF	574 HF
	80 Regolarma Competizione	08 - 08	694 HF	604 HF
MX	85 Regolarma Competizione	08 - 08	694 RSI	604 RSI
	125 Caballero Deluxe	23 - 23	877 HF	675 HF
	125 Caballero Enduro 2T	12 - 10	694 HF	777 HF
	125 Caballero Flat Track	17 - 23	877 HS	675 LS
	125 Caballero Motard 2T	10 - 10	694 HF	777 HF
	125 Caballero Motard 4T	10 - 10	926 HF	777 HF
	125 Caballero Rally	22 - 23	877 HS	675 HF
	125 Caballero Regolarita 4T	10 - 10	926 HF	777 HF
	125 Caballero Scrambler	22 - 23	877 HS	675 HF
	125 Raider	83 - 85	574 HF	
	125 Regolarma Casa	08 - 08	774 HF	544 HF
	125 Regolarma Competizione	08 - 08	694 HF	604 HF
	125 Strada	83 - 85	560 HF	
	125 Supersei Motard	08 - 08	774 HF	544 HF
	125 Trial	78 - 84	595 HF	
	125 Trial Professional	87 - 87	595 HF	595 HF
	125 Trial Progress 1	87 - 87	595 HF	
HP1	125 Sport	86 - 86	560 HF*	
HP1	125 Sport	87 - 87	574 HF*	
HP1	125 Strada	85 - 85	595 HF	
TZ	125 SM	12 - 12	566 HF	
XE	125	22 - 22	840 SI	790 SI
XE	125	23 - 23	965 SI	790 SI
XEF	125 Competition	22 - 22	926 HF	777 HF
XMF	125 Competition	22 - 22	926 HF	777 HF
XX	125	20 - 21	840 RSI	790 RSI
XX	125	22 - 24	965 RSI	790 RSI
	200 Caballero Motard 4T	10 - 10	926 HF	777 HF
	200 Caballero Regolarita 4T	10 - 10	926 HF	777 HF
	201 Trial	85 - 91	595 HF	
	201 Trial Progress 2	87 - 87	595 HF	
	241 Trial Progress 2	87 - 87	595 HF	
	243 Trial	87 - 90	595 HF	595 HF
	250 Coach	91 - 98	519 HF	
	250 Enduro 4T	16 - 17	926 HF	777 HF
	250 K-Roo	93 - 95	559 RSI	559 RSI
	250 Raider	85 - 85	588 HF	
XEF	250	22 - 22	840 SI	790 SI
XEF	250	23 - 23	965 SI	790 SI
XX	250	22 - 24	965 RSI	790 RSI
XXF	250	22 - 24	965 RSI	790 RSI
XE	300	24 - 24	965 SI	790 SI
	301 Trial	85 - 91	595 HF	
	301 Trial Progress 2	87 - 87	595 HF	
	303 Trial Professional	87 - 87	595 HF	595 HF
	305	89 - 90	559 RSI	559 RSI
	307 Trial	91 - 94	559 RSI	559 RSI
	343 Trial Progress 2	87 - 87	595 HF	595 HF
XEF	450	22 - 23	965 SI	790 SI
XEF	450 Rally	22 - 22	840 SI	790 SI
XEF	450 Rally	23 - 23	965 SI	790 SI
XXF	450	22 - 24	965 RSI	790 RSI
	500 Caballero	17 - 17	900 HS	675 LS
	500 Caballero Anniversary	23 - 23	877 HS	675 LS
	500 Caballero Deluxe	23 - 23	877 HS	675 LS
	500 Caballero Explorer	22 - 23	877 HS	675 HF
	500 Caballero Flat Track	23 - 23	877 HS	675 LS
	500 Caballero Rally	22 - 23	877 HS	675 HF
	500 Caballero Scrambler	22 - 23	877 HS	675 HF
	500 Caballero Six Days	22 - 22	877 HS	675 HF
	700 Caballero Scrambler	23 - 23	706 HS	730 LS
<b>GAC</b>				
	50 New T.T.	87 - 87	559 HF	
<b>GARELLI</b>				
	Xo Electric	12 - 12	200 HF	107 HF
	50 Ciclone LC, SM	86 - 86	559 HF	
	50 Flexi	12 - 12	141 HF	
	50 Flo'	00 - 02	123 HF	

**RECOMMENDED**1xx - 2xx = Scooter Pads  
5xx - 9xx = Street, Off Road & Racing Pads  
2xxx = Brake Shoes

GARELLI				
	50 S, Sport	80 - 80	532 HF	
	50 Sahel	91 - 91	607 HF	559 HF
	50 Starter	02 - 02	111 HF	
	50 Tiger XLE	86 - 86	519 HF	519 HF
	50 Urka	91 - 91	519 HF	
	50 Xo	12 - 12	141 HF	105 HF
CPR	50	02 - 02	111 HF	
FX	50	02 - 06	111 HF	
GSP	50	12 - 12	141 HF	105 HF
KRS	50	02 - 02	140 HF	
PMX	50 Rally	00 - 00	111 HF	
PMX	50 Sport	00 - 00	140 HF	
SR	50 Pony	95 - 02	111 HF	2032
	80 Sport	83 - 83	532 HF	
	125 Flexi	12 - 12	200 HF	
	125 Freeland	02 - 02	140 CT	
	125 Joker 2	02 - 02	103 CT	
	125 Panther	02 - 02	115 CT	123 CT
	125 Raider	02 - 02	101 CT	
	125 Tiger XLE	86 - 86	588 HF	574 HF
	125 T-Rex	00 - 00	140 CT	
	125 Xo	12 - 12	200 CT	107 CT
GTA	125	80 - 82	519 HF*	519 HF
GTA	125	83 - 85	519 HF	
GTA	125	86 - 86	560 HF*	
TSR	125	83 - 83	560 HF	
XR	125 Tiger XRD	85 - 85	519 HF	
	150 Freeland	02 - 02	140 CT	
	150 Joker 2	02 - 02	103 CT	
	150 Panther	02 - 02	115 CT	123 CT
	150 Xo	12 - 12	200 CT	107 CT
	200 Xo	12 - 12	197 CT	107 CT
	250 Panther	02 - 02	115 CT	123 CT
	323 Trial	86 - 86	595 HF	
<b>GASGAS</b>				
MC	E 5	21 - 24	794 RSI	794 RSI
	50 Wild HP	04 - 07	671 SI*	671 SI
EC	50 Boy	01 - 04	815 HF	815 HF
EC	50 Rookie	01 - 04	148 HF	
EC	50 Rookie	05 - 05	168 HF	
MC	50	21 - 24	794 RSI	794 RSI
SM	50 Rookie	01 - 02	148 HF	
TXT	50 Boy	01 - 01	815 HF	815 HF
TXT	50 Boy	04 - 04	559 RSI	559 RSI
TXT	50 Rookie	02 - 03	815 HF	815 HF
MC	65	05 - 06	815 HF	815 HF
MC	65	21 - 22	783 RSI	783 RSI
MC	65	23 - 24	791 RSI	791 RSI
TXT	80 Rookie	02 - 03	815 HF	815 HF
MC	85	21 - 24	671 RSI	791 RSI
	125 Delta	91 - 91	559 HF	
	125 Enducross	93 - 93	694 SI	586 SI
	125 Pampera	96 - 03	559 RSI	559 RSI
	125 Pampera	04 - 13	774 HF	815 HF
	125 Trial	91 - 91	559 RSI	
EC	125	97 - 99	671 SI	675 SI
EC	125	00 - 06	694 SI	604 SI
MC	125	03 - 13	694 RSI	604 RSI
MC	125	21 - 24	671 RSI	791 RSI
SM	125	02 - 13	566 HF	604 HF
TX	125 Randone	12 - 13	802 RSI	803 RSI
TXT	125	04 - 13	802 RSI	803 RSI
TXT	125 (Formula cal.)	12 - 13	885 RSI	803 RSI
TXT	125 GP	19 - 23	963 RSI	803 RSI
TXT	125 Pro Racing	14 - 14	939 RSI	803 RSI
TXT	125 Pro Replica	13 - 13	939 RSI	803 RSI
TXT	125 Racing	19 - 23	963 RSI	803 RSI
	200 Pampera	99 - 08	559 RSI	559 RSI
	200 Wild HP	08 - 09	671 SI*	671 SI
EC	200	99 - 99	671 SI	675 SI
EC	200	00 - 09	694 SI	604 SI

\* = 2 sets required / 2 jeux pour l'Avant.

Full compound selection, see under "Brake pad 1:1 Drawings" / Sélection complète de composés, voir "1:1 Schémas Plaquettes de frein".





**RECOMMENDED**

1xx - 2xx = Scooter Pads  
 5xx - 9xx = Street, Off Road & Racing Pads  
 2xxx = Brake Shoes



**GASGAS**

EC	200	17 - 17	694 SI	790 SI
EC	200 Hobby	07 - 16	694 SI	604 SI
EC	200 Ranger Enduro	19 - 19	671 SI	791 SI
TX	200	97 - 98	559 RSI	559 RSI
TXT	200	04 - 10	802 RSI	803 RSI
XC	200	18 - 19	694 SI	790 SI
	240 Wild HP	04 - 06	671 SI*	671 SI
	250 Pampera	96 - 99	559 RSI	559 RSI
	250 Pampera	02 - 13	774 HF	815 HF
	250 Trial	89 - 96	559 RSI	559 RSI
	250 Wild HP	08 - 08	671 SI*	671 SI
EC	250	97 - 99	671 SI	675 SI
EC	250	00 - 11	694 SI	604 SI
EC	250	12 - 20	694 SI	790 SI
EC	250	21 - 23	671 SI	791 SI
EC	250 Enduro GP 18	18 - 19	694 SI	790 SI
EC	250 F	21 - 23	671 SI	791 SI
EC	250 fse	02 - 11	694 SI	604 SI
GT	250 Contact	92 - 93	559 RSI	559 RSI
MC	250	97 - 99	671 RSI	675 RSI
MC	250	00 - 13	694 RSI	604 RSI
MC	250	21 - 24	671 RSI	791 RSI
MC	250 F	21 - 24	671 RSI	791 RSI
SM	250	02 - 13	566 HF	604 HF
TXT	250	04 - 07	802 RSI	803 RSI
TXT	250 (Formula cal.)	12 - 13	885 RSI	803 RSI
TXT	250 GP	19 - 23	963 RSI	803 RSI
TXT	250 Pro Racing	14 - 19	939 RSI	803 RSI
TXT	250 Pro Replica	13 - 14	939 RSI	803 RSI
TXT	250 Racing	19 - 23	963 RSI	803 RSI
XC	250	17 - 19	694 SI	790 SI
TX	270	97 - 98	559 RSI	559 RSI
	280 Pampera	04 - 08	774 HF	815 HF
TXT	280	04 - 04	802 RSI	803 RSI
TXT	280 (Formula cal.)	12 - 12	885 RSI	803 RSI
TXT	280 GP	19 - 23	963 RSI	803 RSI
TXT	280 Pro Racing	14 - 19	939 RSI	803 RSI
TXT	280 Pro Replica	13 - 13	939 RSI	803 RSI
TXT	280 Racing	19 - 23	963 RSI	803 RSI
	300 Wild HP	03 - 05	671 SI*	671 SI
EC	300	99 - 99	671 SI	675 SI
EC	300	00 - 11	694 SI	604 SI
EC	300	12 - 20	694 SI	790 SI
EC	300	21 - 23	671 SI	791 SI
EC	300 Enduro GP 18	18 - 19	694 SI	790 SI
EC	300 Ranger Enduro	19 - 19	671 SI	791 SI
TXT	300	04 - 06	802 RSI	803 RSI
TXT	300 (Formula cal.)	12 - 12	885 RSI	803 RSI
TXT	300 GP	19 - 23	963 RSI	803 RSI
TXT	300 Pro	07 - 11	802 RSI	803 RSI
TXT	300 Pro Racing	14 - 19	939 RSI	803 RSI
TXT	300 Pro Replica	13 - 13	939 RSI	803 RSI
TXT	300 Racing	19 - 23	963 RSI	803 RSI
XC	300	18 - 19	694 SI	790 SI
TX	320	97 - 99	559 RSI	559 RSI
	325 Halley PXC	86 - 86	559 RSI	559 RSI
	327 Trial	89 - 90	559 RSI	559 RSI
GT	327 Contact	89 - 90	559 RSI	559 RSI
EC	350 F	21 - 23	671 SI	791 SI
MC	350 F	22 - 24	671 RSI	791 RSI
	370 Pampera	96 - 00	559 RSI	559 RSI
	400 Pampera	06 - 09	694 SI	604 SI
EC	400 fse	02 - 02	694 SI	604 SI
SM	400 fse	02 - 02	566 HF	604 HF
	450 Wild HP	03 - 09	671 SI*	671 SI
EC	450 fse	03 - 15	694 SI	604 SI
EC	450 FSR	07 - 16	694 SI	604 SI
MC	450 F	21 - 24	671 RSI	791 RSI
RX	450 F	23 - 23	674 SI	791 SI
SM	450 fse	03 - 06	566 HF	604 HF
SM	450 FSR	07 - 13	566 HF	604 HF
	515 Wild HP	09 - 09	671 SI*	671 SI



**RECOMMENDED**

1xx - 2xx = Scooter Pads  
 5xx - 9xx = Street, Off Road & Racing Pads  
 2xxx = Brake Shoes



**GASGAS**

EC	515 fsr	08 - 16	694 SI	604 SI
ES	700	23 - 23	674 HS	675 LS
SM	700	23 - 23	900 HS	675 LS
<b>GENERIC</b>				
	50 Ideo	06 - 13	141 HF	2028
	50 ROC	08 - 11	141 HF	
	50 Stroke	08 - 12	141 HF	
	50 Toxic	07 - 16	168 HF	123 HF
	50 Trigger SM	06 - 14	168 HF	123 HF
	50 Trigger SM Competition	08 - 14	168 HF	123 HF
	50 Trigger X	06 - 14	168 HF	123 HF
	50 Trigger X Competition	08 - 12	168 HF	123 HF
	50 XOR	06 - 13	141 HF	2028
SM	50 Mini Trigger	08 - 09	211 HF	211 HF
X	50 Mini Trigger	08 - 09	211 HF	211 HF
	125 Soho	07 - 16	141 CT	
	125 Stroke	08 - 15	141 CT	
	125 XOR	07 - 11	141 CT	
	125 Zion	08 - 15	163 CT	
<b>GILERA</b>				
SP	01	90 - 90	601 HF	519 HF
	50 503	91 - 94	132 HF	132 HF
	50 AJP Caliper incl. pin/spring	90 - 19	188 HF	
	50 Bullit	90 - 97	595 HF	
	50 DNA	01 - 07	120 HF	143 HF
	50 Eaglet	96 - 96	131 HF	2195
	50 Eaglet	97 - 99	123 HF	102 HF
	50 Easy Moving	96 - 11	130 HF	2187
	50 H@k	99 - 02	105 HF	105 HF
	50 Ice	02 - 05	123 HF	
	50 Rally	87 - 87	131 HF	
	50 Rally, R1	92 - 96	519 HF	
	50 Runner	97 - 05	143 HF	2195
	50 Runner PJ	06 - 11	177 HF	202 HF
	50 Runner SP	06 - 12	177 HF	202 HF
	50 Runner SP, Purejet	98 - 05	143 HF	202 HF
	50 Sioux	92 - 92	519 HF	519 HF
	50 Stalker	97 - 01	123 HF	202 HF
	50 Storm	94 - 98	143 HF	2187
	50 Typhoon	93 - 95	143 HF	2187
	50 Typhoon	96 - 01	130 HF	2200
	50 Zulu	01 - 03	105 HF	105 HF
DT	50 Stalker	01 - 05	123 HF	202 HF
GSM	50 Supermotard	01 - 13	105 HF	105 HF
NRG	50	94 - 95	123 HF	2187
R	50	96 - 96	132 HF	
RC	50 Top Rally	90 - 90	519 HF	519 HF
RCR	50	04 - 13	105 HF	105 HF
RI	50	91 - 91	131 HF	
SMT	50	04 - 13	105 HF	105 HF
	70 Runner Malossi	98 - 98	123 HF	
	80 TG 1, 2, 3	77 - 82	560 HF	
	80 Typhoon	95 - 99	143 HF	2187
	125 Apache	91 - 94	608 HF	575 HF
	125 Arizona Hawk	86 - 89	519 HF	
	125 Cougar	99 - 02	108 CT	
	125 Crono	92 - 95	601 HF	519 HF
	125 DNA	01 - 03	120 CT	143 CT
	125 Fast Bike	88 - 89	588 HF	
	125 Freestyle	92 - 95	601 HF	519 HF
	125 GSM	00 - 00	105 CT	105 CT
	125 HX, HE	83 - 83	519 HF	
	125 KK, KR, KZ	86 - 91	588 HF	519 HF
	125 MX1, MRX, SP01	89 - 93	601 HF	519 HF
	125 Nexus	07 - 12	177 CT	177 CT
	125 R1, R1S	90 - 92	588 HF	519 HF
	125 SP02	90 - 94	601 HF	519 HF
	125 Surfer	00 - 00	559 HF	559 HF
	125 TG 1, 2, 3 (alu wheels)	77 - 85	560 HF	
	125 TG1, GR1, RTX	77 - 85	560 HF	

\* = 2 sets required / 2 jeux pour l'Avant.

Full compound selection, see under "Brake pad 1:1 Drawings" / Sélection complète de composés, voir "1:1 Schémas Plaquettes de frein".

**RECOMMENDED**1xx - 2xx = Scooter Pads  
5xx - 9xx = Street, Off Road & Racing Pads  
2xxx = Brake Shoes

GILERA					
	125 Typhoon	96 - 00	130 CT	2195	
CX	125	91 - 95	601 HF	519 HF	
ER	125 Rally	87 - 87	588 HF		
FX	125 Runner	97 - 99	148 CT	2205	
FX	125 Runner (Grimeca cal.)	00 - 05	120 CT	202 CT	
FX	125 Runner (Hengtong cal.)	00 - 05	177 CT	202 CT	
FX	125 Runner SP (Grimeca cal.)	00 - 03	120 CT	202 CT	
FX	125 Runner SP (Hengtong cal.)	00 - 03	177 CT	202 CT	
MXR	125	90 - 90	588 HF	519 HF	
RC	125 Top Rally	90 - 93	608 HF	575 HF	
RRT	125 Nebraska	87 - 87	588 HF		
RTX	125	86 - 86	588 HF		
RV	125	86 - 88	560 HF*		
RX	125	83 - 83	519 HF		
RX	125 Arizona Hawk	85 - 85	588 HF		
SC	125	06 - 07	189 MS	105 CT	
ST	125 Runner	08 - 11	177 CT	166 CT	
ST	125 Runner	12 - 13	177 CT	202 CT	
VX	125 Runner 4T (Grimeca cal.)	01 - 12	120 CT	166 CT	
VX	125 Runner 4T (Hengtong cal.)	01 - 12	177 CT	166 CT	
X1	125	89 - 89	588 HF	574 HF	
XR2	125	90 - 90	588 HF	519 HF	
FX	150 Runner	97 - 01	148 CT	2205	
	175 Mad Mud	02 - 02	120 CT	143 CT	
	180 DNA	01 - 03	120 CT	143 CT	
FXR	180 Runner	97 - 97	148 CT		
FXR	180 Runner	98 - 99	120 CT		
FXR	180 Runner (Grimeca cal.)	00 - 03	120 CT	202 CT	
FXR	180 Runner (Hengtong cal.)	00 - 03	177 CT	202 CT	
FXR	180 Runner SP (Grimeca cal.)	00 - 00	120 CT	202 CT	
FXR	180 Runner SP (Hengtong cal.)	00 - 00	177 CT	202 CT	
VXR	180 Runner	01 - 08	177 CT		
VXR	180 Runner 4T (Grimeca cal.)	01 - 08	120 CT	166 CT	
VXR	180 Runner 4T (Hengtong cal.)	01 - 08	177 CT	166 CT	
	200 Arizona Hawk	85 - 85	588 HF		
	200 ER	87 - 87	588 HF		
	200 Fast Bike	87 - 87	588 HF	519 HF	
	200 RX	83 - 83	519 HF		
	200 Stalker	97 - 01	123 CT	202 CT	
	200 T4, T4C, T4S	79 - 82	560 HF		
FX	200 Runner	97 - 98	148 CT	2205	
FX	200 Runner SP	98 - 01	120 CT	202 CT	
RV	200	85 - 86	605 HF*	519 HF	
ST	200 Runner	08 - 11	177 CT	166 CT	
VXR	200 Runner 4T (Grimeca cal.)	01 - 09	120 CT	166 CT	
VXR	200 Runner 4T (Hengtong cal.)	01 - 09	177 CT	166 CT	
	250 Arizona Hawk	86 - 91	519 HF		
	250 Arizona Rally	86 - 91	519 HF		
	250 Arizona Rally	08 - 08	588 HF	519 HF	
	250 Nexus	07 - 08	177 MS	177 MS	
	250 Oregon Quad	07 - 11	575 SI*	775 SI	
NGR	250	85 - 85	574 HF*	519 HF	
	350 Dakota	85 - 85	588 HF		
	350 Dakota	86 - 89	594 HF		
	350 Saturno Bialbero	90 - 90	566 HF	519 HF	
XRT	350	90 - 90	588 HF	519 HF	
	500 Dakota	86 - 86	588 HF		
	500 Nexus	04 - 12	151 MS*	157 MS	
	500 Saturno Bialbero	90 - 90	566 HF	519 HF	
	500 Saturno Piuma	90 - 94	566 HF	519 HF	
RC	500 Fuoco ie	08 - 17	202 MS*	191 MS	
RC	500 Fuoco ie (Parking Brake)	08 - 17		209 HF	
	600 Nordwest	91 - 94	601 HF*	519 HF	
	600 Supersport	02 - 02	762 HS*	730 LS	
RC	600	88 - 88	588 HF	519 HF	
RC	600 Top Rally	90 - 94	608 HF	575 HF	
XRT	600	89 - 89	588 HF	519 HF	
GP	800	08 - 15	151 MS*	177 MS	
GP	800 (Parking Brake)	08 - 15		209 HF	
<b>GOES</b>					
	360 Max	08 - 14	914 SI*		

**RECOMMENDED**1xx - 2xx = Scooter Pads  
5xx - 9xx = Street, Off Road & Racing Pads  
2xxx = Brake Shoes

GOES					
	520 Max	07 - 12	914 SI*	799 SI	
G	520	07 - 12	914 SI*	799 SI	
G	525	12 - 14	914 SI*	799 SI	
G	620	11 - 14	914 SI*	799 SI	
G	625 A	12 - 14	914 SI*	799 SI	
<b>HAO-QING</b>					
	125 2C	02 - 02	585 HF		
<b>HARLEY DAVIDSON</b>					
	Livewire	19 - 24	900 H.HS*	730 LS	
FLT	Series	88 - 99	579 H.HS*	668 H.LS	
FXB	Series	74 - 77	679 H.HF		
FXE	Series	74 - 77	679 H.HF	513 H.HF	
S2	Del Mar	24 - 24	900 H.HS	993 H.LS	
S2	Del Mar LE	24 - 24	900 H.HS	993 H.LS	
XL	Series	74 - 77	679 H.HF		
XLH	Series	88 - 99	579 H.HS*	669 H.LS	
X	440	24 - 24	671 H.HF	675 H.HF	
XG	500 Street	14 - 15	924 H.HF	924 H.HF	
XG	500 Street	16 - 18	674 H.HF	671 H.HF	
XG	750 Street	14 - 15	924 H.HF	924 H.HF	
XG	750 Street	16 - 17	674 H.HF	671 H.HF	
XG	750 Street Rod	18 - 20	674 H.HF*	671 H.HF	
XL	883 C Sportster Custom	04 - 13	807 H.HS	808 H.LS	
XL	883 L Sportster Low	06 - 13	807 H.HS	808 H.LS	
XL	883 L Super Low	11 - 13	807 H.HS	808 H.LS	
XL	883 L Super Low	14 - 18	934 H.HS	715 H.LS	
XL	883 N Iron	13 - 13	807 H.HS	808 H.LS	
XL	883 N Iron	14 - 22	934 H.HS	715 H.LS	
XL	883 R Roadster	10 - 13	807 H.HS*	808 H.LS	
XL	883 R Roadster	14 - 15	934 H.HS	715 H.LS	
XL	883 R Sportster	00 - 03	826 H.HS	826 H.LS	
XL	883 Sportster	04 - 13	807 H.HS	808 H.LS	
XL	883 Sportster Custom	00 - 03	826 H.HS	826 H.LS	
XL	883 Sportster R	05 - 13	807 H.HS*	808 H.LS	
XLH	883	70 - 83	537 H.HF		
XLH	883 Sportster	85 - 86	579 H.HF	549 H.HF	
XLH	883 Sportster	87 - 99	579 H.HF	669 H.HF	
XLH	883 Sportster	00 - 03	826 H.HS	826 H.LS	
XLH	883 Sportster Hugger	00 - 03	826 H.HS	826 H.LS	
	975 Bronx	20 - 21	900 H.HS*	675 H.LS	
RH	975 Nightster	22 - 23	830 H.HS	993 H.LS	
XL	1000	78 - 78	537 H.HF	543 H.HF	
XLCH	1000	73 - 73	513 H.HF		
XLCH	1000	78 - 80	537 H.HF	543 H.HF	
XLH	1000 Sportster	79 - 82	537 H.HF*	543 H.HF	
XLH	1000 Sportster	83 - 85	537 H.HF*	549 H.HF	
XLS	1000 Anniversary	82 - 82	537 H.HF*	549 H.HF	
XLS	1000 Roadster	79 - 82	537 H.HF*	543 H.HF	
XLS	1000 Sportster	83 - 83	537 H.HF*	549 H.HF	
XLX	1000 61	83 - 84	537 H.HF	549 H.HF	
XR	1000	85 - 85	537 H.HF*	549 H.HF	
XLH	1100	87 - 88	579 H.HS	669 H.LS	
XLH	1100 Sportster	85 - 86	579 H.HF	549 H.HF	
XLX	1100	86 - 86	579 H.HF	549 H.HF	
VRSCA	1130 V-Rod	02 - 05	826 H.HS*	826 H.LS	
VRSCA	1130 V-Rod	06 - 10	830 H.HS*	830 H.LS	
VRSCB	1130 V-Rod	04 - 04	826 H.HS*	826 H.LS	
VRSCD	1130 Night Rod	06 - 08	830 H.HS*	830 H.LS	
VRSCR	1130 Street Rod	06 - 07	830 H.HS*	830 H.LS	
FL	1200 FLH Police	75 - 79	513 H.HF	513 H.HF	
FLH	1200	74 - 76	513 H.HF	513 H.HF	
FLH	1200	80 - 80	513 H.HF	553 H.HF	
FLH	1200 Anniversary	78 - 78	513 H.HF	513 H.HF	
FLH	1200 Touring	77 - 78	513 H.HF	513 H.HF	
FLHS	1200	77 - 80	513 H.HF	513 H.HF	
FX	1200	74 - 80	537 H.HF	513 H.HF	
FXE	1200	74 - 80	537 H.HF	513 H.HF	
FXS	1200	78 - 79	537 H.HF	513 H.HF	
XL	1200 C Sportster Custom	04 - 13	807 H.HS	808 H.LS	
XL	1200 C, CA, CB, CP Custom	14 - 19	934 H.HS	715 H.LS	

\* = 2 sets required / 2 jeux pour l'Avant.

Full compound selection, see under "Brake pad 1:1 Drawings" / Sélection complète de composés, voir "1:1 Schémas Plaquettes de frein".





**RECOMMENDED**

1xx - 2xx = Scooter Pads  
 5xx - 9xx = Street, Off Road & Racing Pads  
 2xxx = Brake Shoes



**HARLEY DAVIDSON**

XL	1200 CX	17 - 17	934 H.HS*	715 H.LS
XL	1200 Iron	18 - 22	934 H.HS*	715 H.LS
XL	1200 L Sportster Low	07 - 10	807 H.HS	808 H.LS
XL	1200 N Nightster	07 - 12	807 H.HS	808 H.LS
XL	1200 R Sportster Roadster	04 - 09	807 H.HS*	808 H.LS
XL	1200 Roadster	18 - 20	934 H.HS*	715 H.LS
XL	1200 Sportster Custom	00 - 03	826 H.HS	826 H.LS
XL	1200 Sportster Sport	00 - 03	826 H.HS*	826 H.LS
XL	1200 T Super Low	15 - 17	934 H.HS	715 H.LS
XL	1200 V Seventy-Two	11 - 13	807 H.HS	808 H.LS
XL	1200 V Seventy-Two	14 - 16	934 H.HS	715 H.LS
XL	1200 X Forty-Eight	11 - 13	807 H.HS	808 H.LS
XL	1200 X Forty-Eight	14 - 22	934 H.HS	715 H.LS
XL	1200 X Forty-Eight Spec.	19 - 20	934 H.HS	715 H.LS
XLH	1200 Sportster	90 - 99	579 H.HS	669 H.LS
XLH	1200 Sportster	00 - 03	826 H.HS	826 H.LS
XR	1200	08 - 10	860 H.HS*	808 H.LS
XR	1200 X	10 - 13	860 H.HS*	808 H.LS
RA	1250 Pan America	21 - 22	900 H.HS*	675 H.LS
RA	1250 Pan America Special	21 - 22	900 H.HS*	675 H.LS
RH	1250 Sportster S	21 - 23	900 H.HS	993 H.LS
VRSCAW	1250 V-Rod	08 - 10	830 H.HS*	830 H.LS
VRSCDX	1250 Night Rod Special	08 - 17	830 H.HS*	830 H.LS
VRSCF	1250 Muscle	09 - 17	830 H.HS	830 H.LS
VRSCX	1250 V-Rod	08 - 10	830 H.HS*	830 H.LS
FLH	1340 80	78 - 80	513 H.HF	513 H.HF
FLH	1340 80	81 - 81	513 H.HF	553 H.HF
FLH	1340 Classic	82 - 83	543 H.HF*	553 H.HF
FLH	1340 Electra Glide	82 - 83	543 H.HF*	513 H.HF
FLH	1340 Electra Glide Spec.	84 - 84	513 H.HF	553 H.HF
FLH	1340 Heritage	81 - 81	543 H.HF*	553 H.HF
FLHS	1340 Electra Glide Sport	90 - 90	579 H.HS*	668 H.LS
FLHT	1340 Electra Glide	85 - 86	579 H.HF*	549 H.HF
FLHT	1340 Electra Glide Classic	87 - 99	579 H.HS*	669 H.LS
FLHT	1340 Tour Glide	84 - 84	537 H.HF*	553 H.HF
FLHTC	1340 Electra Glide Classic	85 - 86	579 H.HF*	549 H.HF
FLHTC	1340 Electra Glide Classic	90 - 99	579 H.HS*	668 H.LS
FLHTC	1340 Ultra Classic	90 - 99	579 H.HS*	668 H.LS
FLST	1340 Heritage Softail	86 - 87	579 H.HF	549 H.HF
FLST	1340 Heritage Softail	88 - 99	579 H.HS	668 H.LS
FLSTC	1340 Heritage Softail Cl.	90 - 99	579 H.HS	669 H.LS
FLSTF	1340 Fat Boy	90 - 99	579 H.HS	669 H.LS
FLSTN	1340 Heritage Softail Nost.	93 - 99	579 H.HS*	669 H.LS
FLT	1340	84 - 85	579 H.HF	553 H.HF
FLT	1340 80	80 - 81	543 H.HF*	553 H.HF
FLT	1340 80 Classic	81 - 81	543 H.HF*	553 H.HF
FLT	1340 Classic	82 - 83	543 H.HF*	553 H.HF
FLT	1340 Tour Glide	82 - 82	543 H.HF*	553 H.HF
FLT/H	1340 Series	86 - 87	579 H.HS*	668 H.LS
FLTC	1340 Tour Glide Classic	85 - 86	579 H.HF	549 H.HF
FLTC	1340 Tour Glide Classic	90 - 90	579 H.HS*	668 H.LS
FXB	1340 80	80 - 81	537 H.HF	513 H.HF
FXB	1340 Sturgis	82 - 82	537 H.HF*	513 H.HF
FXDB	1340 Dyna Glide Daytona	91 - 99	579 H.HS*	669 H.LS
FXDB	1340 Dyna Glide Sturgis	91 - 99	579 H.HF	669 H.HF
FXDB	1340 Sturgis	91 - 99	579 H.HS	669 H.LS
FXDL	1340 Dyna Low Rider	93 - 99	579 H.HS*	669 H.LS
FXDWG	1340 Dyna Wide Glide	93 - 99	579 H.HS	669 H.LS
FXE	1340	82 - 82	537 H.HF	669 H.HF
FXE	1340	85 - 86	579 H.HF	549 H.HF
FXE	1340 80	78 - 81	537 H.HF	513 H.HF
FXE	1340 Super Glide	83 - 84	537 H.HF*	513 H.HF
FXEF	1340 80 Fat Bob	79 - 81	537 H.HF	513 H.HF
FXLR	1340 Low Rider Custom	87 - 99	579 H.HS	669 H.LS
FXR	1340	78 - 81	537 H.HF	513 H.HF
FXR	1340	87 - 88	579 H.HS	669 H.LS
FXR	1340 Super Glide	82 - 83	537 H.HF	549 H.HF
FXR	1340 Super Glide	85 - 86	579 H.HF	549 H.HF
FXR	1340 Super Glide	90 - 99	579 H.HS	669 H.LS
FXRD	1340 Sport Glide GTE	85 - 86	579 H.HF*	549 H.HF
FXRS	1340 Low Glide	82 - 84	537 H.HF*	549 H.HF
FXRS	1340 Low Rider	85 - 86	579 H.HF*	549 H.HF



**RECOMMENDED**

1xx - 2xx = Scooter Pads  
 5xx - 9xx = Street, Off Road & Racing Pads  
 2xxx = Brake Shoes



**HARLEY DAVIDSON**

FXRS	1340 Low Rider Sport	87 - 99	579 H.HS*	669 H.LS
FXRS	1340 Low Rider Sport Ed.	90 - 99	579 H.HS*	669 H.LS
FXRS	1340 Low Rider, Convert.	90 - 99	579 H.HS*	669 H.LS
FXRS	1340 Super Glide II	82 - 83	537 H.HF*	549 H.HF
FXRT	1340 Sport Glide	85 - 86	579 H.HF*	549 H.HF
FXRT	1340 Sport Glide	90 - 99	579 H.HS*	669 H.LS
FXRT	1340 Super Glide II	83 - 83	537 H.HF	549 H.HF
FXS	1340 80	79 - 81	537 H.HF	513 H.HF
FXS	1340 Low Rider	82 - 82	537 H.HF*	513 H.HF
FXSB	1340 Low Rider	83 - 83	537 H.HF*	549 H.HF
FXST	1340 Softail	84 - 86	579 H.HF	549 H.HF
FXSTC	1340 Softail Custom	85 - 86	579 H.HF	549 H.HF
FXSTC	1340 Softail Custom	88 - 99	579 H.HS	669 H.LS
FXSTS	1340 Springer Softail	90 - 99	579 H.HS	669 H.LS
FXWG	1340	87 - 88	579 H.HS	669 H.LS
FXWG	1340 80	80 - 81	537 H.HF	513 H.HF
FXWG	1340 Wide Glide	82 - 82	537 H.HF*	513 H.HF
FXWG	1340 Wide Glide	83 - 84	537 H.HF	549 H.HF
FXWG	1340 Wide Glide	85 - 86	579 H.HF	549 H.HF
FLHR/I	1450 Road King	00 - 06	826 H.HS*	826 H.LS
FLHRC/I	1450 Road King Classic	00 - 06	826 H.HS*	826 H.LS
FLHRS/I	1450 Road King Custom	04 - 06	826 H.HS*	826 H.LS
FLHT/I	1450 Electra Glide Standard	00 - 06	826 H.HS*	826 H.LS
FLHTC/I	1450 Electra Glide Classic	00 - 06	826 H.HS*	826 H.LS
FLHTCU/I	1450 Ultra Classic Electra Glide	00 - 06	826 H.HS*	826 H.LS
FLHX/I	1450 Street Glide	06 - 06	826 H.HS*	826 H.LS
FLSTC	1450 Softail	06 - 07	826 H.HS	826 H.LS
FLSTC/I	1450 Heritage Softail Classic	00 - 04	826 H.HS	826 H.LS
FLSTCI	1450 Softail	06 - 06	826 H.HS	826 H.LS
FLSTF	1450 Fat Boy	06 - 07	826 H.HS	826 H.LS
FLSTF/I	1450 Fat Boy	00 - 04	826 H.HS	826 H.LS
FLSTFI	1450 Fat Boy	06 - 06	826 H.HS	826 H.LS
FLSTI	1450 Heritage Softail	06 - 06	826 H.HS	846 H.LS
FLSTN/I	1450 Softail Deluxe	06 - 06	826 H.HS	826 H.LS
FLSTS/I	1450 Heritage Springer	00 - 03	579 H.HS	826 H.LS
FLSTSC/I	1450 Springer Softail Classic	06 - 06	579 H.HS	826 H.LS
FLTR/I	1450 Road Glide Classic	00 - 06	826 H.HS*	826 H.LS
FXD	1450 Dyna Super Glide	00 - 03	826 H.HS	826 H.LS
FXDBI	1450 Dyna Street Bob	06 - 06	826 H.HS	826 H.LS
FXDC/I	1450 Dyna Super Glide Custom	05 - 06	826 H.HS	826 H.LS
FXDI	1450 35th Anniversary Super Glide	06 - 06	826 H.HS	846 H.LS
FXDI	1450 Dyna Super Glide	04 - 07	826 H.HS	826 H.LS
FXDL	1450 Dyna Low Rider	00 - 03	826 H.HS*	826 H.LS
FXDLI	1450 Dyna Low Rider	04 - 06	826 H.HS	826 H.LS
FXDS	1450 Dyna Convertible	00 - 02	826 H.HS*	826 H.LS
FXDWG	1450 Dyna Wide Glide	00 - 03	826 H.HS	826 H.LS
FXDWGI	1450 Dyna Wide Glide	04 - 06	826 H.HS	826 H.LS
FXDX	1450 Dyna Super Glide Sport	00 - 03	826 H.HS*	826 H.LS
FXDXI	1450 Dyna Super Glide Sport	04 - 06	826 H.HS	826 H.LS
FXDXT	1450 Dyna Super Glide T-Sport	00 - 03	826 H.HS*	826 H.LS
FXST/I	1450 Softail Standard	00 - 05	826 H.HS	826 H.LS
FXST/I	1450 Softail Standard	06 - 06	826 H.HS	846 H.LS
FXSTB/I	1450 Night Train	00 - 05	826 H.HS	826 H.LS
FXSTB/I	1450 Night Train	06 - 06	826 H.HS	846 H.LS
FXSTD/I	1450 Softail Deuce	00 - 05	826 H.HS	826 H.LS
FXSTD/I	1450 Softail Deuce	06 - 06	826 H.HS	846 H.LS
FXSTS/I	1450 Softail	05 - 05	579 H.HS	826 H.LS
FXSTS/I	1450 Softail	06 - 06	579 H.HS	846 H.LS
FXSTS/I	1450 Springer Softail	00 - 04	579 H.HS	826 H.LS
FLHR	1584 Road King	07 - 07	826 H.HS*	826 H.LS
FLHR	1584 Road King	08 - 10	830 H.HS*	830 H.LS
FLHRC	1584 Road King Classic	07 - 07	826 H.HS*	826 H.LS
FLHRC	1584 Road King Classic	08 - 10	830 H.HS*	830 H.LS
FLHRS	1584 Road King Custom	07 - 07	826 H.HS*	826 H.LS
FLHT	1584 Electra Glide Standard	07 - 07	826 H.HS*	826 H.LS
FLHT	1584 Electra Glide Standard	08 - 10	830 H.HS*	830 H.LS
FLHTC	1584 Electra Glide Classic	07 - 07	826 H.HS*	826 H.LS
FLHTC	1584 Electra Glide Classic	08 - 10	830 H.HS*	830 H.LS
FLHTCi	1584 Ultra Electra Glide Classic	08 - 10	830 H.HS*	830 H.LS
FLHTCU	1584 Ultra Classic Electra Glide	07 - 08	826 H.HS*	826 H.LS
FLHTCU	1584 Ultra Classic Electra Glide	09 - 10	830 H.HS*	830 H.LS
FLHTK	1584 Electra Glide Ultra LTD	10 - 10	830 H.HS*	830 H.LS

\* = 2 sets required / 2 jeux pour l'Avant.

Full compound selection, see under "Brake pad 1:1 Drawings" / Sélection complète de composés, voir "1:1 Schémas Plaquettes de frein".

**RECOMMENDED**

1xx - 2xx = Scooter Pads  
5xx - 9xx = Street, Off Road & Racing Pads  
2xxx = Brake Shoes

**HARLEY DAVIDSON**

FLHX	1584 Street Glide	07 - 07	826 H.HS*	826 H.LS
FLHX	1584 Street Glide	08 - 10	830 H.HS*	830 H.LS
FLSTC	1584 Heritage Softail Classic	07 - 07	826 H.HS	846 H.LS
FLSTC	1584 Heritage Softail Classic	08 - 11	853 H.HS	854 H.LS
FLSTF	1584 Fat Boy	07 - 07	826 H.HS	846 H.LS
FLSTF	1584 Fat Boy	08 - 11	853 H.HS	854 H.LS
FLSTFB	1584 Fat Boy Special	10 - 11	853 H.HS	854 H.LS
FLSTN	1584 Softail Deluxe	07 - 07	826 H.HS	846 H.LS
FLSTN	1584 Softail Deluxe	08 - 11	853 H.HS	854 H.LS
FLSTSC/I	1584 Softail	07 - 07	579 H.HS	846 H.LS
FLTR	1584 Road Glide	08 - 10	830 H.HS*	830 H.LS
FLTRU	1584 Road Glide Ultra	11 - 16	830 H.HS*	830 H.LS
FLTRX	1584 Road Glide Custom	10 - 10	830 H.HS*	830 H.LS
FXCW	1584 Rocker	08 - 09	853 H.HS	854 H.LS
FXCWC	1584 Rocker C	08 - 13	853 H.HS	854 H.LS
FXD	1584 Dyna Super Glide	07 - 07	826 H.HS	826 H.LS
FXD	1584 Dyna Super Glide	08 - 10	853 H.HS	854 H.LS
FXDB	1584 Dyna Street Bob	07 - 07	826 H.HS	826 H.LS
FXDB	1584 Dyna Street Bob	08 - 13	853 H.HS	854 H.LS
FXDC	1584 Dyna Super Glide Custom	07 - 07	826 H.HS	826 H.LS
FXDC	1584 Dyna Super Glide Custom	08 - 13	853 H.HS	854 H.LS
FXDF	1584 Fat Bob	08 - 11	853 H.HS	854 H.LS
FXDL	1584 Dyna Low Rider	07 - 07	826 H.HS	826 H.LS
FXDL	1584 Dyna Low Rider	08 - 13	853 H.HS	854 H.LS
FXDWG	1584 Dyna Wide Glide	07 - 07	826 H.HS	826 H.LS
FXDWG	1584 Dyna Wide Glide	08 - 10	853 H.HS	854 H.LS
FXST	1584 Softail Standard	07 - 07	826 H.HS	846 H.LS
FXST	1584 Softail Standard	08 - 14	853 H.HS	854 H.LS
FXST	1584 Softail Standard	15 - 17	860 H.HS	854 H.LS
FXSTB	1584 Night Train	07 - 07	826 H.HS	846 H.LS
FXSTB	1584 Night Train	08 - 09	853 H.HS	854 H.LS
FXSTC	1584 Softail Custom	07 - 07	826 H.HS	846 H.LS
FXSTC	1584 Softail Custom	08 - 10	853 H.HS	854 H.LS
FXSTD	1584 Softail Deuce	07 - 07	826 H.HS	846 H.LS
FLD	1690 Switchback	12 - 16	853 H.HS	854 H.LS
FLHR	1690 Road King	11 - 16	830 H.HS*	830 H.LS
FLHRC	1690 Road King Classic	11 - 16	830 H.HS	830 H.LS
FLHTC	1690 Electra Glide Classic	11 - 16	853 H.HS	854 H.LS
FLHTCU	1690 Ultra Classic Electra Glide	11 - 16	830 H.HS*	830 H.LS
FLHTCUL	1690 Electra Glide Ultra Classic Low	15 - 16	830 H.HS*	830 H.LS
FLHTCUTG	1690 Tri Glide Ultra	14 - 16	922 H.HS*	923 H.LS
FLHTCUTG	1690 Tri Glide Ultra Classic Trike	09 - 13	830 H.HS*	904 H.LS
FLHTK	1690 Ultra Classic Electra Glide	10 - 16	830 H.HS*	830 H.LS
FLHTK	1690 Ultra Electra Glide	11 - 16	853 H.HS	854 H.LS
FLHTKL	1690 Ultra Limited Low	15 - 16	830 H.HS*	830 H.LS
FLHX	1690 Street Glide	11 - 16	830 H.HS*	830 H.LS
FLHXS	1690 Street Glide Special	14 - 16	830 H.HS*	830 H.LS
FLHXXX	1690 Street Glide Trike	10 - 11	830 H.HS*	904 H.LS
FLRT	1690 Freewheeler	15 - 16	922 H.HS*	923 H.LS
FLS	1690 Softail Slim	12 - 14	853 H.HS	854 H.LS
FLS	1690 Softail Slim	15 - 17	860 H.HS	854 H.LS
FLSTC	1690 Heritage Softail Classic	12 - 14	853 H.HS	854 H.LS
FLSTC	1690 Heritage Softail Classic	15 - 17	860 H.HS	854 H.LS
FLSTF	1690 Fat Boy	12 - 14	853 H.HS	854 H.LS
FLSTF	1690 Fat Boy	15 - 17	860 H.HS	854 H.LS
FLSTF	1690 Fat Boy Special	12 - 14	853 H.HS	854 H.LS
FLSTFB	1690 Fat Boy	12 - 14	853 H.HS	854 H.LS
FLSTFB	1690 Fat Boy	15 - 17	860 H.HS	854 H.LS
FLSTN	1690 Softail Deluxe	12 - 14	853 H.HS	854 H.LS
FLSTN	1690 Softail Deluxe	15 - 17	860 H.HS	854 H.LS
FLTRX	1690 Road Glide	15 - 16	830 H.HS*	830 H.LS
FLTRXS	1690 Road Glide Special	15 - 16	830 H.HS*	830 H.LS
FXDB	1690 Dyna Street Bob	14 - 17	853 H.HS	854 H.LS
FXDBA	1690 Dyna Street Bob	13 - 17	853 H.HS	854 H.LS
FXDBB	1690 Dyna Street Bob	14 - 17	853 H.HS	854 H.LS
FXDBP	1690 Dyna Street Bob	13 - 17	853 H.HS	854 H.LS
FXDC	1690 Dyna Super Glide Custom	14 - 14	853 H.HS	854 H.LS
FXDF	1690 Dyna Wide Glide	12 - 17	853 H.HS	854 H.LS
FXDF	1690 Fat Bob	12 - 17	853 H.HS*	854 H.LS
FXDL	1690 Dyna Low Rider	14 - 17	853 H.HS*	854 H.LS
FXDLS	1690 Dyna Low Rider S	17 - 17	853 H.HS*	854 H.LS
FXS	1690 Blackline	13 - 17	853 H.HS	854 H.LS

**RECOMMENDED**

1xx - 2xx = Scooter Pads  
5xx - 9xx = Street, Off Road & Racing Pads  
2xxx = Brake Shoes

**HARLEY DAVIDSON**

FXSB	1690 Breakout	14 - 14	853 H.HS	854 H.LS
FXSB	1690 Breakout	15 - 17	860 H.HS	854 H.LS
FLDE	1750 Softail Deluxe	18 - 19	860 H.HS	949 H.LS
FLFB	1750 Fat Boy	18 - 20	860 H.HS	949 H.LS
FLHC	1750 Heritage Classic	18 - 19	860 H.HS	949 H.LS
FLHR	1750 Road King	17 - 22	830 H.HS*	830 H.LS
FLHRC	1750 Road King Classic	17 - 17	830 H.HS*	830 H.LS
FLHRXS	1750 Road King Special	17 - 22	830 H.HS	830 H.LS
FLHT	1750 Electra Glide Standard	19 - 22	830 H.HS*	830 H.LS
FLHTCU	1750 Ultra Classic Electra Glide	17 - 19	830 H.HS*	830 H.LS
FLHTCUTG	1750 Tri Glide Ultra	17 - 18	922 H.HS*	923 H.LS
FLHTK	1750 Ultra Limited	17 - 22	830 H.HS*	830 H.LS
FLHTKL	1750 Ultra Limited Low	17 - 19	830 H.HS*	830 H.LS
FLHX	1750 Street Glide	17 - 22	830 H.HS*	830 H.LS
FLHX	1750 Street Glide Special	17 - 19	830 H.HS*	830 H.LS
FLHXS	1750 Street Glide Special	17 - 22	830 H.HS*	830 H.LS
FLRT	1750 Freewheeler	17 - 18	922 H.HS*	923 H.LS
FLSB	1750 Sport Glide	18 - 20	860 H.HS*	949 H.LS
FLSL	1750 Softail Slim	18 - 20	860 H.HS	949 H.LS
FLTRU	1750 Road Glide Ultra	17 - 19	830 H.HS*	830 H.LS
FLTRX	1750 Road Glide	17 - 22	830 H.HS*	830 H.LS
FLTRXS	1750 Road Glide Special	17 - 22	830 H.HS*	830 H.LS
FXBB	1750 Street Bob	18 - 22	860 H.HS	949 H.LS
FXBR	1750 Breakout	18 - 19	860 H.HS	949 H.LS
FXFB	1750 Fat Bob	18 - 20	860 H.HS	949 H.LS
FXLR	1750 Low Rider	18 - 20	860 H.HS	949 H.LS
FXST	1750 Softail Standard	22 - 22	860 H.HS	949 H.LS
FLHRSE5	1802 CVO Road King	14 - 15	830 H.HS*	830 H.LS
FLHTKSE	1802 CVO Limited	14 - 16	830 H.HS*	830 H.LS
FLHXSE	1802 CVO Street Glide	10 - 16	830 H.HS*	830 H.LS
FLSS	1802 Softail Slim S	16 - 17	860 H.HS	854 H.LS
FLSTFB	1802 Fat Boy S	16 - 17	860 H.HS	854 H.LS
FLSTNSE	1802 CVO Softail Deluxe	14 - 14	853 H.HS*	854 H.LS
FLSTNSE	1802 CVO Softail Deluxe	15 - 17	860 H.HS*	854 H.LS
FLTRUSE	1802 CVO Road Glide Ultra	11 - 16	830 H.HS	830 H.LS
FXSBSE	1802 CVO Breakout	13 - 14	853 H.HS	854 H.LS
FLFBS	1870 Fat Boy	18 - 22	860 H.HS	949 H.LS
FLHCS	1870 Heritage Classic	18 - 22	860 H.HS	949 H.LS
FLHTCUTG	1870 Tri Glide Ultra	19 - 22	830 H.HS*	948 H.HS
FLHTKSE	1870 CVO Limited	17 - 17	830 H.HS*	830 H.LS
FLHXSE	1870 CVO Street Glide	17 - 17	830 H.HS*	830 H.LS
FLRT	1870 Freewheeler	19 - 22	830 H.HS*	948 H.HS
FLTRK	1870 Road Glide Limited	20 - 22	830 H.HS*	830 H.LS
FXBBS	1870 Street Bob	22 - 22	860 H.HS	949 H.LS
FXBRS	1870 Breakout	18 - 20	860 H.HS	949 H.LS
FXDR	1870	19 - 20	860 H.HS	949 H.LS
FXFBS	1870 Fat Bob	18 - 22	860 H.HS*	949 H.LS
FLHTCUTGSE	1917 CVO Tri Glide	20 - 22	830 H.HS*	948 H.HS
FLHTKSE	1917 CVO Limited	18 - 19	830 H.HS*	830 H.LS
FLHXSE	1917 CVO Street Glide	18 - 22	830 H.HS*	830 H.LS
FLHXST	1917 Street Glide Special ST	22 - 22	830 H.HS*	830 H.LS
FLTRKSE	1917 CVO Road Glide Limited	22 - 22	830 H.HS*	830 H.LS
FLTRXSE	1917 CVO Road Glide	18 - 22	830 H.HS*	830 H.LS
FLTRXST	1917 Road Glide Special ST	22 - 22	830 H.HS*	830 H.LS
FXLRS	1917 Low Rider S	22 - 22	860 H.HS*	949 H.LS
FXLRST	1917 Low Rider ST	22 - 22	860 H.HS*	949 H.LS

**HERCULES**

	50 Gipsy, Splinter, Reggae	95 - 95	123 HF	2012
	50 Limbo	95 - 95	2011	2012
	50 Ultra	79 - 83	532 HF*	
RS	50	79 - 83	532 HF*	
SR	50 Samba	93 - 93	2012	2012
	80 Ultra AC	81 - 81	532 HF*	
	80 Ultra AC Ch.	81 - 83	532 HF*	
	80 Ultra Chopper	81 - 83	532 HF*	
RX-9	80	82 - 83	532 HF	
RX-9	80 Aircooled	82 - 83	532 HF	
SR	80 Samba	93 - 93	2012	2012
	125 Silver Star Classic	93 - 93	506 HF	
GP	125 Supra	80 - 80	541 HF	
KX-5	125	87 - 87	532 HF	

\* = 2 sets required / 2 jeux pour l'Avant.

Full compound selection, see under "Brake pad 1:1 Drawings" / Sélection complète de composés, voir "1:1 Schémas Plaquettes de frein".





**RECOMMENDED**

1xx - 2xx = Scooter Pads  
 5xx - 9xx = Street, Off Road & Racing Pads  
 2xxx = Brake Shoes



HERCULES				
ZX	125	86 - 86	519 HF	
	280 ATV	07 - 07	810 SI*	
	300 ATV Sport	07 - 07	810 SI*	
HERO ENVOY				
	50	99 - 99	105 HF	
HIGHLAND				
	450 MX	06 - 09	671 RSI	675 RSI
	950 V2 Motard	00 - 08	671 HF	675 HF
	950 V2 Outback	99 - 08	671 HF	675 HF
HM				
CRE	50	98 - 01	608 HF	548 HF
CRE	50	06 - 13	774 HF	604 HF
CRE	50 Baja	97 - 01	548 HF	548 HF
CRE	50 Six Comp.	07 - 12	928 HF	790 HF
CRM	50 Derapage Comp.	07 - 12	928 HF	790 HF
	125 Supermotard	00 - 02	694 HF	604 HF
CR	125 Supermotard	04 - 06	694 RSI	777 RSI
CRE	125 Enduro	95 - 01	694 SI	604 SI
CRE	125 Enduro	02 - 06	694 SI	777 SI
CRE	125 Six Comp.	10 - 11	928 HF	790 HF
CRE	125 Supermotard	03 - 03	694 HF	604 HF
CRM	125 Derapage Comp. 2T	11 - 12	928 HF	790 HF
CRM	125 Derapage Comp. 4T	11 - 12	928 HF	790 HF
CRM	125 X Supermotard	07 - 07	843 RSI	777 RSI
	250 Supermotard	00 - 02	694 HF	604 HF
CRE	250 Enduro	95 - 01	694 SI	604 SI
CRE	250 Enduro	02 - 03	694 SI	777 SI
CRE	250 F Enduro	04 - 13	694 SI	777 SI
CRE	250 Supermotard	03 - 03	694 HF	604 HF
CRE	250 Supermotard	04 - 07	694 RSI	777 RSI
CRE	250 X Enduro	04 - 13	694 SI	777 SI
CRF	250 Supermotard	04 - 06	694 RSI	777 RSI
CRM	250 X Supermotard	07 - 13	843 RSI	777 RSI
CRE	450 F Enduro	02 - 13	694 SI	777 SI
CRE	450 X Enduro	04 - 13	694 SI	777 SI
CRF	450 Supermotard	02 - 06	694 RSI	777 RSI
CRM	450 X Supermotard	07 - 13	843 RSI	777 RSI
CRM	500 X Supermotard	07 - 13	843 RSI	777 RSI
HONDA				
	50 Dio, Life	94 - 96	2057	2057
	50 Formula	94 - 98	123 HF	
	50 Giorno	92 - 94	670 HF	
	50 Jazz	92 - 92	670 HF	
	50 Sky Classic	00 - 03	123 HF	2012
	50 Sky Vetro	00 - 02	123 HF	2012
	50 Super Dio (Japan)	94 - 96	2057	2057
C	50 all models	75 - 93	2012	2012
CB	50 all models	80 - 81	2013	2013
CB	50 J, K1	75 - 79	525 HF	2013
CB	50 Replica	99 - 00		144 HF
CF	50 Chaly	79 - 79	2012	2012
CR	50 RE, RF	84 - 85	2057	2057
CRF	50 F	04 - 24	2010	2010
CRM	50	88 - 92	100 HF	121 HF
CRM	50	93 - 96	115 HF	121 HF
CRM	50 (Made in Spain)	93 - 96	139 HF	
GP	50 Dio	89 - 90	670 HF	2011
GP	50 Dio	91 - 91	115 HF	2057
HSC	50 ZR, 01 Scooter	92 - 95	115 HF	2057
MB	50 S	80 - 82	100 HF	2013
MBX	50	80 - 82	100 HF	2013
MBX	50 S	83 - 85	103 HF	2013
MRX	50	88 - 92	100 HF	2013
MT	50 S	80 - 93	2013	2013
MTX	50 SC-SD	83 - 84	2013	2013
NA	50 Express	79 - 81	2010	2011
NB	50 ME, Aero	83 - 87	2010	2011
NC	50 Express	77 - 80	2010	2010



**RECOMMENDED**

1xx - 2xx = Scooter Pads  
 5xx - 9xx = Street, Off Road & Racing Pads  
 2xxx = Brake Shoes



HONDA				
NC	50 Express	81 - 83	2010	2011
ND	50 C, ML Melody	82 - 85	2010	2011
NE	50 MF, MG, TH Vision	85 - 87	2010	2011
NH	50 Lead	83 - 83	2012	2011
NH	50 Lead	86 - 93	110 HF	2011
NH	50 Lead	94 - 94	121 HF	2011
NH	50 Lead (Drum vers.)	94 - 94	2012	2011
NH	50 Lead SS,MR,MSE	84 - 85	112 HF	2011
NN	50 MD Gyro	84 - 84	2010	2010
NP	50 Melody D Mini	83 - 87	2010	2011
NPS	50 Zoomer	01 - 12	2057	2057
NQ	50 D, Spree	84 - 87	2010	2010
NS	50 F, Aero	88 - 91	103 HF	2011
NS-1	50	91 - 94	103 HF	2011
NSC	50 Vision	10 - 18	205 HF	
NSR	50	89 - 90	103 HF	2013
NT	50 F, G, H Melody Mini	85 - 87	2010	2010
NU	50 MC Runaway, Express	82 - 83	2057	2011
NV	50 MSD Stream	84 - 86	2011	2011
NX	50 A, B, MC Caren	82 - 82	2010	2011
OR	50	93 - 93	2010	2011
PA	50	78 - 81	2010	2074
PA	50	82 - 83	2010	2010
PA	50 Camino	80 - 86	2074	2074
PC	50 K1	79 - 79	2010	2010
PF	50 M Nocio	75 - 80	2074	2074
PK	50 Walaroo DX-STD	90 - 01	2057	2012
PX	50	82 - 83	2074	2011
PX	50	84 - 84	2074	
PXR	50 all models	85 - 02	2193	2194
QA	50 K1-K3	87 - 89	2074	2074
QR	50	93 - 03	2010	2057
QR	50 ED, EF	82 - 92	2010	2011
R	50 Monkey	88 - 88	618 HF	2012
SA	50 Elite LX, SR	88 - 93	2010	2011
SA	50 J Vision	88 - 94	2057	2057
SB	50	88 - 89	2010	2010
SC	50 1-ZX	92 - 95	670 HF	
SFX	50 Sport	96 - 04	123 HF	2012
SGX	50 Sky DX	97 - 03	123 HF	2012
SH	50 City Express	84 - 96	2080	2012
SH	50 Fifty, Scoopy	00 - 03	123 HF	
SH	50 Scoopy	88 - 04	2012	2080
SH	50 T	97 - 97	123 HF	2012
SJ	50 Bali	93 - 98	124 HF	2012
SP	50	91 - 91	100 HF	
SP	50	92 - 92	670 HF	
SR	50 Dio	93 - 93	115 HF	2057
SR	50 Super Dio	91 - 92	115 HF	2057
SRX	50 Shadow	98 - 99	144 HF	
SS	50 K2	75 - 77	2012	2012
SS	50 ZB2	75 - 80	525 HF	2012
ST	50 Dax	78 - 93	2012	2012
SXR	50	98 - 00	123 HF	
SZ	50 Tact S	93 - 96	115 HF	2057
SZX	50 X8R-S	98 - 04	123 HF	129 HF
SZX	50 X8R-X	98 - 01	123 HF	129 HF
TG	50 M Gyro S	85 - 86	2010	2010
TLM	50 F	85 - 85	2057	2057
XL	50	77 - 82	2013	2013
XR	50 R	00 - 03	2010	2010
Z	50 R, RD	80 - 99	2010	2010
ZX	50 Super Dio	92 - 01	115 HF	2057
CR	60 RF, RG	85 - 86	2057	2057
ATC	70 all models	78 - 85		2069
C	70 all models	75 - 83	2012	2012
CF	70 K2, C	78 - 78	2012	2012
CRF	70 F	04 - 14	2057	2057
CT	70	91 - 94	2010	2010
ST	70 Dax	78 - 93	2012	2012
TRX	70	86 - 87	2048*	2041
XR	70	97 - 12	2057	2057

\* = 2 sets required / 2 jeux pour l'Avant.

Full compound selection, see under "Brake pad 1:1 Drawings" / Sélection complète de composés, voir "1:1 Schémas Plaquettes de frein".

**RECOMMENDED**1xx - 2xx = Scooter Pads  
5xx - 9xx = Street, Off Road & Racing Pads  
2xxx = Brake Shoes

HONDA					
	75 Yupy	90 - 95	121 HF	2012	
CRM	75 R	90 - 94	603 HF	604 HF	
NF	75	79 - 79	2012	2012	
NS-1	75	92 - 00	119 HF	121 HF	
NSR	75 FI	88 - 00	103 HF	2013	
SA	75 Vision	89 - 92	2012	2057	
SH	75 Scoopy	88 - 95	2012	2080	
XR	75 K4	75 - 79	2013	2013	
XR	75 K5	79 - 79	2012	2013	
CB	80	80 - 81	100 HF		
CH	80 Elite	85 - 88	2012	2057	
CR	80 R	86 - 91	584 SI	2043	
CR	80 R, RB	92 - 02	584 RSI	604 RSI	
CR	80 R2	85 - 85	2013	2013	
CR	80 RA, RB	80 - 81	2013	2013	
CR	80 RC	82 - 82	2013	2057	
CR	80 RD, RE	83 - 84	2057	2057	
CR	80 RF	85 - 85	2057	2043	
CRF	80 F	04 - 14	2057	2057	
CRM	80	89 - 92	584 HF	604 HF	
Lead	80 SS	85 - 85	628 HF	2011	
MB	80	80 - 83	548 HF	2043	
MBX	80	83 - 85	551 HF	2013	
MBX	80	86 - 87	558 HF	2013	
MBX	80 DX	82 - 86	551 HF	2013	
MBX	80 FWD	83 - 86	536 HF*	2013	
MBX	80 SW, SWD	83 - 83	551 HF	2013	
MCX	80	82 - 85	548 HF	2013	
MTX	80 R	87 - 87	558 HF	2013	
MTX	80 RF	83 - 84	2013	2013	
NH	80 Aero	85 - 85	2012	2057	
NH	80 Lead Scooter	85 - 85	112 HF	2011	
NH	80 Lead Scooter	86 - 95	110 HF	2011	
NH	80 MD Lead, Aero	83 - 84	2012	2011	
NSR	80 R	87 - 92	103 HF	121 HF	
NSR	80 R	93 - 95	119 HF	121 HF	
R	80 Lead	88 - 95	618 HF	2011	
SH	80 Scoopy	88 - 93	2012	2080	
XR	80	79 - 84	2013	2013	
XR	80 R	85 - 88	2057	2057	
CR	85 R, R Expert	03 - 12	592 RSI	604 RSI	
C	90	93 - 02	2013	2013	
C	90 all models	75 - 92	2012	2012	
CB	90	79 - 84	525 HF		
EZ	90 Cub	90 - 95	2012	2012	
NH	90 Yupy	90 - 94	121 HF	2013	
SRX	90 Shadow	99 - 99	144 HF		
CB	100 N	79 - 80		2013	
CRF	100 F	04 - 14	2057	2057	
EX	100 Bali	96 - 03	124 HF		
H	100 A, SD, SG, SJ	82 - 92	2012	2012	
NF	100 Supra	97 - 99	119 HF		
NH	100 Lead	00 - 08	104 HF		
NSF	100	06 - 06	688 DC	604 HF	
SJ	100 Bali	97 - 03	124 HF	2012	
XL	100 all models	78 - 85	2013	2013	
XR	100	81 - 84	2013	2013	
XR	100 R	85 - 03	2057	2057	
AFS	110 Wave	12 - 19	216 HF		
ATC	110 all models	79 - 85		2019	
CG	110	77 - 79	525 HF		
CRF	110 F	13 - 24	2057	2057	
NHX	110	08 - 09	125 HF		
NHX	110	10 - 12	104 CT		
NSC	110 Vision	10 - 12	205 HF		
NSC	110 Vision	17 - 20	236 HF		
SCV	110 Lead	08 - 09	125 HF		
SCV	110 Lead	10 - 12	205 HF		
ANF	125 i Innova	07 - 11	180 CT	2012	
ANF	125 Innova	03 - 06	180 CT	2012	
ATC	125 ME, MF, MG, MH	84 - 87	2012	2019	
C	125 Super Cub	19 - 24	216 CT		

**RECOMMENDED**1xx - 2xx = Scooter Pads  
5xx - 9xx = Street, Off Road & Racing Pads  
2xxx = Brake Shoes

HONDA					
CA	125 Rebel	95 - 96	713 HF	2026	
CA	125 Rebel	97 - 00	588 HF	2026	
CB	125	72 - 74	2012	2012	
CB	125 F	15 - 16	638 HF		
CB	125 F	17 - 21	958 HF		
CB	125 J	79 - 79	525 HF	2013	
CB	125 R	18 - 24	940 HS	915 HF	
CB	125 RS	83 - 83	536 HF	2069	
CB	125 S	76 - 78	525 HF	2013	
CB	125 S	79 - 82	2013	2013	
CB	125 S	84 - 85	2041	2012	
CB	125 T	85 - 85		2069	
CB	125 T, Superdream	82 - 83	572 HF	2069	
CB	125 T, T1, T2, TZ	77 - 81		2069	
CB	125 TDC	83 - 89	542 HF	2069	
CB	125 TT	90 - 90	647 HF	2069	
CBF	125	09 - 18	797 HF		
CBR	125 R	03 - 10	797 HF	784 HF	
CBR	125 R	11 - 18	797 HF	915 HF	
CBX	125 Custom	88 - 88	551 HF	2013	
CBX	125 F	84 - 88	572 HF	2020	
CD	125	82 - 82	2023	2069	
CG	125	04 - 08	536 HF		
CG	125 A, B, C	77 - 84	2012	2012	
CG	125 E, F, J	85 - 91	2041	2012	
CH	125 D, E, Spacy, Elite	83 - 84	2012	2012	
CH	125 Spacy	94 - 01	125 CT	2041	
CLR	125 Cityfly	99 - 03	588 HF		
CM	125	82 - 85	2023	2069	
CR	125 M2, M3, M4	76 - 78	2013	2013	
CR	125 R	79 - 81	2031	2041	
CR	125 R	95 - 01	694 RSI	604 RSI	
CR	125 R	02 - 07	694 RSI	777 RSI	
CR	125 RC	82 - 82	2041	2041	
CR	125 RD	83 - 83	2042	2042	
CR	125 RE, RF	84 - 85	558 SI	2042	
CR	125 RG	86 - 86	558 SI	2047	
CR	125 RH, RJ, RK	87 - 94	603 RSI	604 RSI	
CRE	125	02 - 07	694 SI	777 SI	
CRE	125 RR	11 - 11	859 SI	777 SI	
CRF	125 F	14 - 24	694 SI	2057	
CRM	125 , R	90 - 98	588 HF	646 HF	
CT	125 C	85 - 85	2013	2013	
CT	125 Trail	21 - 21	797 HF	784 HF	
FES	125 Pantheon	98 - 02	147 CT	2198	
FES	125 Pantheon	03 - 06	147 CT	161 CT	
FES	125 S-Wing	07 - 11	192 CT	193 CT	
FS	125 Sonic	03 - 04	551 HF		
MBX	125 RWB	84 - 86	551 HF	2042	
MSX	125	14 - 24	797 HF	915 HF	
MT	125 R	77 - 77	525 HF	2013	
MT	125 R	78 - 78	517 HF	2013	
MTX	125 Camel, Italy	88 - 98	588 HF	2012	
MTX	125 R	84 - 95	558 HF	2013	
MTX	125 R, Italy	86 - 86	588 HF	2013	
MTX	125 RWD	83 - 84	2013	2013	
NES	125 @	01 - 06	104 CT	2208	
NH	125 Lead Scooter	86 - 87	112 CT	2012	
NH	125 Lead, Aero	83 - 84	2012	2012	
NS	125	89 - 89	622 HF	618 HF	
NS	125 Italy	85 - 88	588 HF	2012	
NSR	125 F	88 - 89	558 HF	2012	
NSR	125 F, R	90 - 92	588 HF	646 HF	
NSR	125 R, Italy	89 - 01	588 HF	646 HF	
NSS	125 Forza	15 - 19	183 CT	193 CT	
NX	125 , Transcity	90 - 98	588 HF	2013	
PCX	125	09 - 17	205 MS	2208	
PCX	125	18 - 20	228 CT	2208	
PCX	125 (Nissin cal.)	18 - 20	233 CT	2208	
PS	125 i	07 - 13	125 CT	2208	
R	125 Lead	88 - 88	618 HF	2013	
RS	125	95 - 03	566 DC	618 RQ	

\* = 2 sets required / 2 jeux pour l'Avant.

Full compound selection, see under "Brake pad 1:1 Drawings" / Sélection complète de composants, voir "1:1 Schémas Plaquettes de frein".





**RECOMMENDED**

1xx - 2xx = Scooter Pads  
 5xx - 9xx = Street, Off Road & Racing Pads  
 2xxx = Brake Shoes



HONDA					
RS	125 R	91 - 94	627 HF*	618 HF	
RTV	125 NRS, Italy	87 - 87	588 HF	2012	
SES	125 Dylan	02 - 07	125 CT	2208	
SH	125	02 - 08	125 CT	2208	
SH	125	13 - 20	183 CT	193 HF	
SH	125 i	09 - 12	192 HF	193 HF	
SH	125 i Vetro	24 - 24	183 HF	193 HF	
SH	125 Mode	14 - 20	205 CT		
SL	125 K1A	76 - 76	2012	2012	
SL	125 K1D, E, F, G, K2A	76 - 80	2013	2013	
TL	125	76 - 76	2013	2013	
TRX	125	85 - 88	2012*	2019	
VT	125 C1 Shadow	99 - 08	688 HF	2026	
VT	125 C2 Shadow	99 - 08	688 HF	2026	
XL	125 K2	78 - 78	2013	2013	
XL	125 K3	79 - 79	2012	2013	
XL	125 R	86 - 86	558 HF	2013	
XL	125 R, P.D., Italy	85 - 85	588 HF	2013	
XL	125 R, P.D., Italy, EX	87 - 87	588 HF	2013	
XL	125 S	79 - 84	2013	2013	
XLR	125 R	98 - 01	694 HF	2013	
XLV	125 Varadero	01 - 11	688 HF	784 HF	
XR	125 L	03 - 07	694 HF	2013	
Z	125 Monkey	19 - 24	797 HF	784 HF	
ADV	150	19 - 21	233 CT	193 CT	
ADV	150 ABS	20 - 21	228 CT	193 CT	
CBR	150 R	00 - 10	797 HF	784 HF	
CG	150	04 - 05	536 HF		
CH	150 D Elite	85 - 87	2012	2012	
CRF	150 F	03 - 06	694 SI	2013	
CRF	150 R	07 - 24	592 RSI	777 RSI	
FES	150 Pantheon	99 - 02	147 CT	2198	
FES	150 Pantheon	03 - 06	147 CT	161 CT	
FES	150 S-Wing	07 - 11	192 CT	193 CT	
NES	150 @	01 - 06	104 CT	2208	
NS	150	92 - 95	121 HF		
NSR	150	02 - 02	688 HF	611 HF	
PCX	150	12 - 17	205 MS	2208	
PCX	150	18 - 20	233 CT	2208	
PS	150 i	07 - 11	125 CT	2208	
SES	150 Dylan	02 - 06	125 CT	2208	
SH	150	02 - 08	125 CT	2208	
SH	150	13 - 18	183 CT	193 HF	
SH	150 i	09 - 12	192 HF	193 HF	
SH	150 i Vetro	24 - 24	183 HF	193 HF	
ADV	160	24 - 24	228 CT	193 CT	
CB	175 K3-K7	74 - 76		2068	
CD	175 all models	71 - 78	2019		
ATC	185 A, S, SB	80 - 83	2012	2019	
CBX	185 Custom	88 - 88		2013	
CBX	185 F	84 - 84		2026	
CD	185 T	78 - 82	2023	2069	
CM	185 T	78 - 79	2023	2069	
XL	185 S	79 - 83	2013	2013	
ATC	200	81 - 83	2012	2019	
ATC	200 X	83 - 85	592 SI	562 SI	
ATC	200 X	86 - 87	592 SI	592 SI	
CD	200 T	79 - 79	2023	2069	
CM	200 TA, TB	80 - 82	2023	2069	
CTX	200	04 - 06	694 SI	2013	
MTX	200 R	85 - 86	558 HF	2013	
MTX	200 RWD	83 - 84	2013	2013	
TL	200 J, Y	76 - 78	2013	2013	
TLR	200 D, E, F	83 - 85	2057	2057	
TLR	200 G, H	86 - 87	2013	2057	
TRX	200	84 - 84	2044*	2019	
TRX	200	90 - 91	2083*	2019	
TRX	200 D Type II	91 - 97	2083*	2019	
TRX	200 SX	86 - 88	2083*	2019	
XL	200 R	83 - 84	2013	2013	
XL	200 R, P.D., Italy	85 - 85	588 HF	2012	
XR	200	80 - 84	2013	2013	



**RECOMMENDED**

1xx - 2xx = Scooter Pads  
 5xx - 9xx = Street, Off Road & Racing Pads  
 2xxx = Brake Shoes



HONDA					
XR	200 R	84 - 02	2013	2013	
XR	200 R, Pro Link	81 - 83	2013	2013	
TLM	220	89 - 91	664 HF	629 HF	
CRF	230	04 - 09	694 SI	2013	
CRF	230 L	08 - 10	694 SI	604 SI	
CRF	230 M	09 - 12	694 SI	604 SI	
SL	230	97 - 01	694 HF	604 HF	
	250 Steed	93 - 96	627 HF		
ATC	250 ES, SX	85 - 87	2019	2024	
ATC	250 R	81 - 81	536 SI	2014	
ATC	250 R	82 - 84	584 SI	562 SI	
ATC	250 R	85 - 86	558 SI	558 SI	
ATC	250 X	85 - 85	558 SI	562 SI	
AX-1	250	90 - 90	603 HF	629 HF	
CA	250 Rebel	90 - 95	638 HF	2058	
CB	250	88 - 98	600 HF	2058	
CB	250	92 - 05	627 HF	2058	
CB	250 G, T	74 - 76	501 HF	2024	
CB	250 K3-K5	73 - 75	2071	2024	
CB	250 N	78 - 81	526 HF	2058	
CB	250 NA, NB, T, TZ	77 - 81	526 HF	2058	
CB	250 Nighthawk	91 - 02	2023	2069	
CB	250 Rebel	86 - 96	551 HF		
CB	250 RS	80 - 84	526 HF	2068	
CB	250 RS	85 - 85	558 HF	2068	
CBF	250	04 - 08	688 HF		
CBR	250 F	86 - 86	593 HF*		
CBR	250 Hurricane	87 - 87	593 HF*	614 HF	
CBR	250 Nighthawk	92 - 95	627 HF		
CBR	250 R (Bybre cal)	11 - 11	674 HS	675 LS	
CBR	250 R (Nissin cal)	11 - 13	627 HS	881 LS	
CBR	250 R ABS (Nissin cal)	11 - 13	828 HS	881 LS	
CBR	250 R, RR	90 - 90	627 HF*	614 HF	
CBR	250 RJ	88 - 88	627 HF*	614 HF	
CBR	250 RR	17 - 21	700 HS	881 LS	
CBX	250 RSE	84 - 85	542 HF	2026	
CBX	250 S	88 - 88	572 HF		
CD	250 UJ	88 - 92	600 HF	2069	
CH	250 Elite	85 - 86	2041	2041	
CH	250 Elite	87 - 90	2041	2041	
CH	250 Spacy	85 - 86	558 HF	2082	
CH	250 Spacy, Freeway Fusion	88 - 93	104 MS	2041	
CJ	250 T	76 - 78	501 HF	2024	
CL	250 SC	81 - 81	2023	2068	
CM	250 C	82 - 83	2023	2069	
CM	250 TB	81 - 81	526 HF	2058	
CMX	250 C Rebel	96 - 00	713 HF	2069	
CMX	250 Rebel	85 - 12	551 HF	2069	
CN	250	93 - 04	127 CT	2041	
CN	250 Helix	86 - 87	160 CT	2189	
CN	250 Helix (Fusion)	92 - 92	127 CT	2082	
CN	250 Helix (Fusion)	93 - 03	183 MS	2082	
CN	250 Scooter	88 - 92	127 CT	2189	
CN	250 Spazio	88 - 89	558 HF	2041	
CN	250 Spazio	90 - 92	572 HF	2189	
Cota	250 4RT	04 - 16	802 RSI	803 RSI	
CR	250 R	81 - 82	2030	2041	
CR	250 R	83 - 83		2042	
CR	250 R	87 - 94	603 RSI	604 RSI	
CR	250 R	95 - 01	694 RSI	604 RSI	
CR	250 R	02 - 07	694 RSI	777 RSI	
CR	250 RE, RF	84 - 85	558 SI	2042	
CR	250 RG	86 - 86	558 SI	2047	
CR	250 RZ, RA	79 - 80	2031	2075	
CRE	250	02 - 07	694 SI	777 SI	
CRE	250 F	04 - 04	694 SI	777 SI	
CRF	250 F	19 - 24	694 SI	777 SI	
CRF	250 L	13 - 15	859 SI	915 SI	
CRF	250 L ABS	17 - 21	859 SI	915 SI	
CRF	250 M	14 - 18	859 SI	915 SI	
CRF	250 R	04 - 24	694 RSI	777 RSI	
CRF	250 Rally	17 - 19	859 SI	915 SI	

\* = 2 sets required / 2 jeux pour l'Avant.

Full compound selection, see under "Brake pad 1:1 Drawings" / Sélection complète de composés, voir "1:1 Schémas Plaquettes de frein".

**RECOMMENDED**1xx - 2xx = Scooter Pads  
5xx - 9xx = Street, Off Road & Racing Pads  
2xxx = Brake Shoes

HONDA					
CRF 250 RX	19 - 24	694 SI	777 SI		
CRF 250 X	04 - 19	694 SI	777 SI		
CRM 250 R	90 - 90	603 HF	629 HF		
FES 250 Foresight	98 - 99	156 MS	2198		
FES 250 Foresight	00 - 07	156 MS	161 MS		
FL 250 Odyssey	77 - 84	525 HF	2019		
FTR 250	86 - 86	558 HF	558 HF		
GB 250 Clubman	88 - 97	542 HF			
NS 250	89 - 89	622 HF	618 HF		
NS 250 R	85 - 85	572 HF*	542 HF		
NSF 250 R	11 - 21	782 DC	618 RQ		
NSR 250 R	87 - 87	593 HF*	542 HF		
NSR 250 R, SP	90 - 90	622 HS*	614 LS		
NSR 250 RJ	88 - 89	622 HF*	614 HF		
NSS 250	00 - 04	156 MS	158 MS		
NSS 250	05 - 13	192 MS	193 MS		
NSS 250 Forza	00 - 04	156 MS	158 MS		
NSS 250 Forza	05 - 13	192 MS	193 MS		
NSS 250 Jazz	01 - 04	156 MS	158 MS		
NX 250	88 - 90	603 SI	2029		
PS 250	05 - 06	192 MS			
RS 250 R	91 - 92	622 DC*	614 HF		
RS 250 R	93 - 93	566 DC*	618 RQ		
RTL 250 SG	86 - 86	2013	2013		
TL 250 K1	79 - 79	2013	2013		
TLM 250 RJ	89 - 89	2013	2013		
TLR 250 R	85 - 87	2013	2013		
TRX 250	85 - 87	2044*	2024		
TRX 250 EX Sportrax	01 - 08	592 SI*	2055		
TRX 250 R	86 - 89	603 SI*	558 SI		
TRX 250 Recon	97 - 21	2083*	2055		
TRX 250 X	08 - 13	592 SI*	2055		
TRX 250 X Fourtrax	87 - 87	603 SI*	558 SI		
TRX 250 X Fourtrax	88 - 92	584 SI*	584 SI		
VT 250 F	83 - 87	552 HF	2068		
VT 250 F	88 - 90	593 HF	2068		
VT 250 Spada	89 - 89	627 HF	614 HF		
VTR 250	88 - 89	552 HF	2068		
VTR 250	90 - 90	593 HS	2068		
VTR 250	98 - 02	654 HF	614 HF		
VTZ 250	88 - 99	593 HF	2068		
XL 250	78 - 79	2070	2023		
XL 250 Degree	91 - 91	603 SI	2029		
XL 250 R	82 - 83	2041	2029		
XL 250 R	84 - 87	558 HF	2013		
XL 250 S	78 - 80	2023	2029		
XL 250 S	81 - 81	2023	2026		
XLR 250 R	88 - 89	558 SI	2013		
XLR 250 R Baja	88 - 90	603 SI	629 SI		
XLR 250 R SPL	94 - 94	694 SI	604 SI		
XR 250	79 - 80	2023	2029		
XR 250 L	91 - 92	603 SI	604 HF		
XR 250 L	93 - 97	694 HF	604 HF		
XR 250 R	81 - 83	2030	2029		
XR 250 R	84 - 87	558 SI	2013		
XR 250 R	88 - 89	603 SI	2013		
XR 250 R	90 - 95	603 SI	604 SI		
XR 250 S	96 - 00	694 HF	604 HF		
Cota 260 4Ride	16 - 24	939 RSI	803 RSI		
Cota 260 4RT	04 - 24	802 RSI	803 RSI		
Cota 260 4RT Race Replica	15 - 24	939 RSI	803 RSI		
TLM 260 R	90 - 90	664 HF	629 HF		
CB 300	10 - 10	688 HF			
CB 300 R	18 - 24	940 HS	915 HF		
CB 300 R Neo Sports Cafe	19 - 19	940 HS	915 HF		
CBR 300 F	14 - 16	700 HS	881 LS		
CBR 300 F ABS	14 - 17	700 HS	881 LS		
CBR 300 R	14 - 23	700 HS	881 LS		
CMX 300 Rebel	17 - 18	700 HS	881 LS		
Cota 300 RR	16 - 19	939 RSI	803 RSI		
CRF 300 L	21 - 21	859 SI	915 SI		
CRF 300 Rally	21 - 21	859 SI	915 SI		

**RECOMMENDED**1xx - 2xx = Scooter Pads  
5xx - 9xx = Street, Off Road & Racing Pads  
2xxx = Brake Shoes

HONDA					
NSS 300 Forza	14 - 17	192 MS	193 MS		
NSS 300 Forza	18 - 20	183 MS	193 MS		
SH 300 i	07 - 19	192 MS	193 MS		
SH 300 i SH30	15 - 18	183 MS	193 MS		
TRX 300	88 - 00		2024		
TRX 300 EX Sportrax	01 - 08	592 SI*	592 SI		
TRX 300 X	09 - 09	592 SI*	592 SI		
XR 300	10 - 12	694 HF	604 HF		
Cota 301 RR	20 - 24	939 RSI	803 RSI		
Cota 301 RR Race Replica	20 - 24	939 RSI	803 RSI		
350 Forza	21 - 23	183 MS	193 MS		
ADV 350	22 - 24	183 MS	193 MS		
ATC 350 X	85 - 85	558 SI	562 SI		
ATC 350 X	86 - 89	603 SI	562 SI		
CB 350 F, F1	73 - 76	501 HF	2024		
CB 350 K4	74 - 74	2071	2024		
CB 350 S.G. (U.K. only)	87 - 90	593 HF*	2058		
FL 350 R Odyssey	85 - 87	2044*	610 HF		
NX 350	88 - 99	593 HF	2013		
SH 350	21 - 22	183 MS	193 MS		
TRX 350 all models	86 - 89	2045	2046		
TRX 350 Rancher /ES 2x4, 4x4	00 - 09	2085*	2207		
XL 350	76 - 78	2070	2023		
XL 350 R	84 - 87	558 HF	2029		
XR 350 R	83 - 83	2042	2013		
XR 350 R	84 - 85	558 SI	2013		
CB 360 G, T	73 - 76	501 HF	2024		
CJ 360 T	76 - 78	501 HF	2024		
CL 360	74 - 77	501 HF	2024		
400 Xelvis	93 - 93	542 HF	542 HF		
CB 400	81 - 82	542 HF	542 HF		
CB 400 A	77 - 81	526 HF	2058		
CB 400 F, F1, F2	75 - 79	501 HF	2024		
CB 400 Four	81 - 85	542 HF*	2058		
CB 400 Hawk	81 - 85	542 HF	542 HF		
CB 400 N	78 - 82	517 HF	2058		
CB 400 N	83 - 85	542 HF*	2058		
CB 400 N	86 - 86	593 HF	2058		
CB 400 N, T, Hawk	78 - 82	526 HF	2058		
CB 400 NZ	79 - 79	517 HF*	2024		
CB 400 Super Four	92 - 95	654 HS*	614 LS		
CB 400 Super Four S	97 - 02	727 HS*			
CB 400 T1, T2	77 - 78	526 HF	2058		
CB 400 Twin	82 - 86	542 HF	2058		
CB-1 400 (CB 400 F)	89 - 90	627 HS	614 LS		
CBR 400 F	92 - 96	593 HS*	657 LS		
CBR 400 F, FII	85 - 85	542 HF*	542 HF		
CBR 400 R	87 - 87	593 HF*	542 HF		
CBR 400 RR	87 - 89	627 HS*	614 LS		
CBX 400 Custom	88 - 88	571 HF	571 HF		
CBX 400 F	85 - 86	571 HF	571 HF		
CBX 400 F, F2, F2C	82 - 84	552 HF	571 HF		
CM 400 A, T, TZ	79 - 79	526 HF	2058		
CM 400 C	81 - 81	572 HF	2058		
CM 400 E	80 - 81	2071	2058		
CM 400 T	79 - 81	526 HF	2058		
CM 400 T	82 - 84	542 HF	2058		
CX 400	81 - 81	517 HF			
FJS 400 Silverwing	06 - 08	156 MS	184 MS		
FJS 400 Silverwing (Parking Brake)	06 - 08		209 HF		
FL 400 R Pilot	89 - 90	2044*	610 HF		
GB 400 T.T.	88 - 92	542 HF	2058		
GL 400	77 - 80	517 HF*			
NS 400 R	85 - 87	572 HS*	542 LS		
NTV 400 Bros II	88 - 88	622 HF	614 HF		
NV 400 Custom	88 - 88	571 HF	542 HF		
NV 400 Steed	88 - 88	600 HF			
NV 400 Steed	92 - 93	627 HS			
RVF 400 RR (NC35)	90 - 96	622 HF*	623 HF		
SW-T 400	09 - 13	192 MS	184 MS		
SW-T 400 ABS	09 - 14	192 MS	184 MS		
TRX 400 AT	04 - 11	2085*	2207		

\* = 2 sets required / 2 jeux pour l'Avant.

Full compound selection, see under "Brake pad 1:1 Drawings" / Sélection complète de composés, voir "1:1 Schémas Plaquettes de frein".





**RECOMMENDED**

1xx - 2xx = Scooter Pads  
 5xx - 9xx = Street, Off Road & Racing Pads  
 2xxx = Brake Shoes



HONDA					
TRX	400 EX Sportrax	01 - 08	592 SI*	592 SI	
TRX	400 Fourtrax EX	99 - 00	592 SI*	592 SI	
TRX	400 FW Fourtrax Foreman	95 - 02	2085*	2207	
TRX	400 X	09 - 12	592 SI*	592 SI	
VF	400 F	85 - 86	552 HF	571 HF	
VF	400 FD	83 - 85	552 HF*	571 HF	
VF	400 Integra	86 - 88	572 HF	572 HF	
VFR	400 R	86 - 86	593 HF*	593 HF	
VFR	400 R	87 - 88	593 HS*	614 LS	
VFR	400 R	89 - 92	622 HS*	623 LS	
VRX	400 T Roadstar	95 - 99	700 HS	614 LS	
VT	400 E	83 - 86	552 HF	571 HF	
VTR	400 R (NC 30)	90 - 90	622 HS*	623 LS	
XLR	400	83 - 83	2077	2026	
XR	400 R	96 - 04	694 SI	604 SI	
XR	400 Supermotard	00 - 03	694 RSI	604 RSI	
TRX	420 FA / FPA	09 - 13	592 SI*	813 SI	
TRX	420 FPE / FPM 4x4	09 - 14	592 SI*		
XR	440 R	00 - 03	694 SI	604 SI	
CB	450 DX	89 - 92	598 HF	598 HF	
CB	450 K5, K6, K7	72 - 77	501 HF	2072	
CB	450 N	84 - 85	561 HF	2058	
CB	450 N	86 - 89	598 HF	2058	
CB	450 S	86 - 88	593 HF*	2058	
CB	450 SC Nighthawk	82 - 82	561 HF	2058	
CB	450 SC Nighthawk	83 - 86	572 HF	2058	
CB	450 T	82 - 86	542 HF	2058	
CM	450 A, C	82 - 86	542 HF	2058	
CMX	450 Rebel	86 - 88	542 HF	2058	
CR	450 R	81 - 81	2030		
CRE	450 F	02 - 06	694 SI	777 SI	
CRF	450 L	19 - 21	694 RSI	777 RSI	
CRF	450 R	02 - 24	694 RSI	777 RSI	
CRF	450 R-S	22 - 24	694 RSI	777 RSI	
CRF	450 RWE	19 - 24	694 RSI	777 RSI	
CRF	450 RX	17 - 24	694 SI	777 SI	
CRF	450 X	05 - 24	694 SI	777 SI	
TRX	450 EX Sportrax	01 - 05	592 SI*	592 SI	
TRX	450 Foreman ES, Foreman S	98 - 04	2085*	2207	
TRX	450 R	04 - 09	694 SI*	813 SI	
CR	480 R	82 - 82	2030	2041	
CR	480 R	83 - 83		2042	
	500 Pioneer	15 - 20	982 PSI*	976 PSI	
CB	500	94 - 96	627 HS	2059	
CB	500	97 - 05	674 HS	675 LS	
CB	500 F	72 - 75	501 HF	2072	
CB	500 F	13 - 21	700 HS	881 LS	
CB	500 F	22 - 24	994 HS	881 LS	
CB	500 Hornet	24 - 24	994 HS*	881 LS	
CB	500 S	98 - 03	674 HS	675 LS	
CB	500 T	75 - 78	501 HF	2072	
CB	500 X	13 - 21	700 HS	881 LS	
CB	500 X	22 - 24	994 HS	881 LS	
CBF	500	04 - 08	700 HS	657 LS	
CBF	500 ABS	04 - 08	828 HS	657 LS	
CBR	500 F (Austria)	87 - 90	593 HS*	542 LS	
CBR	500 R	13 - 21	700 HS	881 LS	
CBR	500 R	22 - 24	994 HS	881 LS	
CL	500	23 - 24	700 HS	881 LS	
CMX	500 Rebel	17 - 23	700 HS	881 LS	
CMX	500 Rebel S	20 - 20	700 HS	881 LS	
CR	500 R	87 - 94	603 RSI	604 RSI	
CR	500 R	95 - 01	694 RSI	604 RSI	
CR	500 RE, RF	84 - 85	558 SI	2042	
CR	500 RG	86 - 86	558 SI	2047	
CX	500	78 - 80	517 HF*	2059	
CX	500	81 - 81	572 HF*		
CX	500 C	81 - 82	542 HF*	2059	
CX	500 Euro	82 - 84	572 HF*	572 HF	
CX	500 Silver W., Turbo	83 - 85	542 HF*	542 HF	
CX	500 Turbo	82 - 83	542 HF*	572 HF	
CX	500 Z, A, B	79 - 81		2059	



**RECOMMENDED**

1xx - 2xx = Scooter Pads  
 5xx - 9xx = Street, Off Road & Racing Pads  
 2xxx = Brake Shoes



HONDA					
FT	500	82 - 84	542 HF*	542 HF	
GB	500 T.T.	88 - 92	542 HF	2059	
GL	500	82 - 82	572 HF*	542 HF	
GL	500 D	81 - 82	542 HF*	2059	
GL	500 I	81 - 82	572 HF*	2059	
NS	500 R	85 - 85	542 HS*	542 LS	
NX	500 Dominator (Austria)	88 - 92	647 HS	614 LS	
NX	500 Dominator (Austria)	93 - 96	600 HS	614 LS	
NX	500 Dominator (Austria)	97 - 99	671 HS	675 LS	
SCL	500	23 - 24	700 HS	881 LS	
TRX	500 all models	05 - 14	829 SI*	2046	
TRX	500 Foreman, Rubicon	00 - 09	2085*	2072	
VF	500 F, Fil	84 - 86	542 HF*	542 HF	
VT	500 C Shadow	83 - 86	542 HF	2058	
VT	500 E	83 - 85	552 HF*	2058	
VT	500 ED	82 - 82	552 HF	2058	
XBR	500 S	85 - 89	542 HF	2055	
XL	500 R	83 - 87	558 HF	2026	
XL	500 RC	82 - 82	2077	2026	
XL	500 SB	81 - 81	2075	2068	
XL	500 SZ	80 - 80	2023	2026	
XR	500 R	86 - 86	558 SI	2026	
XR	500 R Pro Link	81 - 82	2030	2026	
XR	500 R, Pro Link	83 - 84	558 HF	2013	
XR	500 SZ, SA	79 - 80	2031	2026	
CB	550 F	75 - 79	501 HF	2072	
CB	550 K	74 - 78	501 HF	2072	
CB	550 SC	83 - 84	542 HF	2058	
CBX	550 F, F2	82 - 86	552 HF*	571 HF	
	600 Steed	88 - 91	600 HS		
	600 Steed	92 - 02	627 HS		
CB	600 Hornet	98 - 06	627 HS*	657 LS	
CB	600 Hornet	07 - 12	627 HS*	834 LS	
CB	600 Hornet (Japan)	98 - 99	734 HS*	657 LS	
CB	600 Hornet ABS	07 - 12	828 HS*	657 LS	
CB	600 Hornet, S	00 - 03	627 HS*	657 LS	
CBF	600 N	04 - 11	627 HS*	657 LS	
CBF	600 N ABS	08 - 11	828 HS*	657 LS	
CBF	600 S	04 - 11	627 HS*	657 LS	
CBF	600 S ABS	08 - 11	828 HS*	657 LS	
CBR	600 F	11 - 13	627 HS*	834 LS	
CBR	600 F ABS	11 - 13	828 HS*	657 LS	
CBR	600 F Hurricane	87 - 90	593 HS*	542 LS	
CBR	600 F, Super Sport	91 - 94	593 HS*	657 LS	
CBR	600 F3	95 - 98	627 HS*	657 LS	
CBR	600 F4, F4 Sport	99 - 06	734 HS*	657 LS	
CBR	600 RR	03 - 04	734 HS*	657 LS	
CBR	600 RR	05 - 06	809 HS*	657 LS	
CBR	600 RR	07 - 17	809 HS*	834 LS	
CBR	600 RR	18 - 24	947 HS*	834 LS	
CBR	600 RR ABS	09 - 18	809 HS*	834 LS	
CBX	600 E	85 - 85	542 HF*		
FJS	600 Silverwing	01 - 08	156 MS	184 MS	
FJS	600 Silverwing	09 - 18	192 MS	184 MS	
FJS	600 Silverwing (Parking Brake)	01 - 18		209 HF	
NTV	600 Bros I	88 - 93	622 HF	614 HF	
NTV	600 Revere	88 - 92	593 HF	614 HF	
NV	600 C	88 - 96	600 HF	2059	
SW-T	600	11 - 13	192 MS	184 MS	
VT	600 C, Shadow	88 - 93	647 HS	2059	
VT	600 C, Shadow	94 - 00	627 HS	2059	
VT	600 CD Shadow VLX	94 - 00	627 HS*	2059	
XL	600 LM, RM	85 - 87	542 HF	2026	
XL	600 R	83 - 86	558 HF	2026	
XL	600 V, Transalp	87 - 90	542 HS	2026	
XL	600 V, Transalpino	91 - 93	647 HS	614 LS	
XL	600 V, Transalpino	94 - 96	700 HS	614 LS	
XL	600 V, Transalpino	97 - 99	694 HS*	614 LS	
XML	600 LM	87 - 91	558 HF	2026	
XR	600 R	83 - 87	558 SI	2013	
XR	600 R	88 - 90	603 SI	2013	
XR	600 R	91 - 92	603 SI	604 SI	

\* = 2 sets required / 2 jeux pour l'Avant.

Full compound selection, see under "Brake pad 1:1 Drawings" / Sélection complète de composés, voir "1:1 Schémas Plaquettes de frein".

**RECOMMENDED**

1xx - 2xx = Scooter Pads  
5xx - 9xx = Street, Off Road & Racing Pads  
2xxx = Brake Shoes



HONDA					
XR	600 R	93 - 00	694 SI	604 SI	
CB	650	79 - 81	526 HF	2027	
CB	650	85 - 85	542 HF*		
CB	650 C	80 - 85	526 HF	2027	
CB	650 F	14 - 19	627 HS*	881 LS	
CB	650 R Neo Sports Cafe	19 - 21	940 HS*	881 LS	
CB	650 SC Nighthawk	83 - 85	542 HF*	2059	
CB	650 SCC Nighthawk	82 - 82	561 HF*	2027	
CB	650 Z	78 - 81	526 HF*	2027	
CBR	650 F	14 - 20	627 HS*	881 LS	
CBR	650 F ABS	14 - 20	700 HS*	881 LS	
CBR	650 R	19 - 24	940 HS	881 LS	
CBX	650 E	83 - 90	552 HF*	2059	
CBX	650 ED, SC, SCD	83 - 83	542 HF*	2059	
CX	650 C	83 - 86	542 HF*	2059	
CX	650 E	83 - 86	572 HF*	542 HF	
CX	650 Turbo	83 - 86	542 HF*	542 HF	
FMX	650 Rally	05 - 08	627 HS	614 LS	
FX	650 Vigor	99 - 02	674 HS	675 LS	
GL	650 D	83 - 84	542 HF*	2059	
NT	650 Hawk GT	88 - 91	627 HS	614 LS	
NT	650 V Deauville	98 - 00	674 HS*	614 LS	
NT	650 V Deauville	01 - 01	674 HS*	657 LS	
NT	650 V Deauville	02 - 05	735 HS*	736 LS	
NTV	650	94 - 97	654 HS*	614 LS	
NTV	650 Bros	88 - 97	622 HS*	614 LS	
NTV	650 Revere	88 - 93	627 HS	614 LS	
NX	650 Dominator	93 - 96	600 HS	614 LS	
NX	650 Dominator	97 - 99	674 HS	675 LS	
NX	650 Dominator J-K	88 - 92	647 HS	614 LS	
SLR	650	97 - 99	674 HS	675 LS	
TRX	650 FA Rincon	03 - 05	2085*	813 SI	
TRX	650 FGA Rincon	04 - 05	2085*	813 SI	
XL	650 V Transalp	00 - 07	694 HS*	614 LS	
XR	650 L	93 - 18	694 HF	604 HF	
XR	650 R	00 - 11	694 SI	604 SI	
XRV	650 Africa Twin	88 - 89	647 HS	614 LS	
DN-01	680	08 - 11	828 HS*	700 LS	
DN-01	680 (Parking Brake)	08 - 11		209 HF	
TRX	680 FGA6 Rincon	06 - 15	829 SI*	813 SI	
TRX	680 FGA6 Rincon	06 - 15	829 SI*	813 SI	
	700 Pioneer	14 - 21	982 PSI*	976 PSI	
CB	700 SC	84 - 86	542 HF*	2046	
CTX	700	14 - 18	700 HS	881 LS	
CTX	700 D ABS w/DCT	13 - 15	700 HS	881 LS	
CTX	700 D ABS w/DCT (Parking Brake)	13 - 15		879 HF	
CTX	700 N	14 - 18	700 HS	881 LS	
CTX	700 ND ABS w/DCT	14 - 15	700 HS	881 LS	
CTX	700 ND ABS w/DCT (Parking Brake)	14 - 15		879 HF	
NC	700 D Integra	12 - 13	828 HS	657 LS	
NC	700 D Integra w/DCT (Parking Brake)	12 - 13		879 HF	
NC	700 S	12 - 13	627 HS	614 LS	
NC	700 SA ABS	12 - 13	828 HS	657 LS	
NC	700 SD ABS	12 - 13	828 HS	657 LS	
NC	700 SD ABS w/DCT (Parking Brake)	12 - 13		879 HF	
NC	700 X	12 - 13	627 HS	614 LS	
NC	700 XA ABS	12 - 13	828 HS	657 LS	
NC	700 XD ABS	12 - 13	828 HS	657 LS	
NC	700 XD ABS w/DCT (Parking Brake)	12 - 13		879 HF	
NT	700 Deauville ABS	06 - 12	828 HS*	736 LS	
NT	700 V Varadero, ABS	10 - 13	828 HS*	736 LS	
TRX	700 XX	08 - 12	694 SI*	829 SI	
VF	700 C Magna	84 - 84	542 HF*	2059	
VF	700 C Magna	85 - 86	572 HF*	2046	
VF	700 C Magna	87 - 87	542 HF	2046	
VF	700 F Interceptor	84 - 85	572 HF*	542 HF	
VF	700 S	84 - 85	542 HF*	2059	
VFR	700 F Interceptor	88 - 89	627 HS*	614 LS	
VFR	700 F, F2	86 - 87	600 HS*	542 LS	
VT	700 C Shadow	84 - 85	561 HF*	2059	
VT	700 C Shadow	86 - 86	561 HF*	2046	

**RECOMMENDED**

1xx - 2xx = Scooter Pads  
5xx - 9xx = Street, Off Road & Racing Pads  
2xxx = Brake Shoes



HONDA					
VT	700 C, Shadow	87 - 87	542 HF	2046	
XL	700 Transalp	08 - 11	694 HS*	614 LS	
XL	700 Transalp ABS	08 - 12	828 HS*	657 LS	
	750 Shadow Aero	24 - 24	700 HS	715 LS	
	750 Shadow Phantom	24 - 24	700 HS	715 LS	
ADV	750 X-ADV	17 - 24	241 MS*	240 HF	
ADV	750 X-ADV (Parking Brake)	17 - 24		209 HF	
CB	750 A	76 - 78	501 HF	2027	
CB	750 C	80 - 81	526 HF*	2027	
CB	750 C	82 - 84	542 HF*	2027	
CB	750 C, F, FI, K	85 - 86	542 HF*	2027	
CB	750 F	77 - 80	517 HF*	517 HF	
CB	750 F	81 - 82	542 HF*	542 HF	
CB	750 F1	75 - 76	501 HF	509 HF	
CB	750 Hornet	23 - 24	994 HS*	881 LS	
CB	750 K	81 - 82	542 HF*	542 HF	
CB	750 K Four	77 - 78	501 HF	2027	
CB	750 K, L	79 - 80	526 HF*	2027	
CB	750 K0-K6 Four	70 - 76	502 HF	2027	
CB	750 KZ	82 - 82	542 HF	2027	
CB	750 N, F, Seven Fifty	92 - 95	627 HS*	657 LS	
CB	750 PZ	81 - 84	526 HF	2027	
CB	750 SC	82 - 83	572 HF*	2027	
CB	750 SS	77 - 79	508 HF*	517 HF	
CBR	750 Hurricane	87 - 00	600 HS*	542 LS	
CBX	750	84 - 88	542 HF*	542 HF	
CBX	750 F	84 - 88	542 HF*	542 HF	
NC	750 D Integra	14 - 19	242 MS	240 HF	
NC	750 D Integra w/DCT (Parking Brake)	14 - 19		209 HF	
NC	750 Integra	16 - 18	242 MS	240 HF	
NC	750 Integra DCT ABS	14 - 19	242 MS	240 HF	
NC	750 S w/DCT	14 - 21	700 HS	881 LS	
NC	750 S w/DCT (Parking Brake)	14 - 21		879 HF	
NC	750 X w/DCT	14 - 19	700 HS	881 LS	
NC	750 X w/DCT (Parking Brake)	14 - 19		879 HF	
NC	750 XAE	14 - 19	700 HS	881 LS	
NM4	750 Vultus ABS w/DCT	15 - 18	700 HS	881 LS	
NM4	750 Vultus ABS w/DCT (Parking Brake)	15 - 18		879 HF	
NR	750	92 - 92	622 HS*	657 LS	
NV	750 CG Shadow	86 - 89	542 HF		
RVF	750 RR (RC-45)	94 - 98	622 HS*	623 LS	
VF	750 C	82 - 84	542 HF*	2059	
VF	750 C, CD Magna	94 - 94	700 HS	2046	
VF	750 C, Magna	88 - 93	542 HF	2046	
VF	750 F	83 - 84	542 HF*	542 HF	
VF	750 S	85 - 85	542 HF*	2059	
VF	750 Sport	82 - 83	542 HF*	2059	
VFR	750 F	86 - 87	600 HS*	542 LS	
VFR	750 F	88 - 98	627 HS*	700 LS	
VFR	750 R	88 - 93	622 HS*	623 LS	
VP	750 CH, Custom	87 - 87	542 HF	2046	
VT	750 Black Widow	01 - 03	700 HS	2046	
VT	750 C	83 - 85	561 HF	2059	
VT	750 C, Shadow	86 - 96	542 HF	2046	
VT	750 C2 Shadow A.C.E.	97 - 03	700 HS	2046	
VT	750 C2 Shadow Spirit	07 - 11	700 HS	2046	
VT	750 C2B	11 - 18	700 HS		
VT	750 C2S ABS	13 - 14	828 HS	715 LS	
VT	750 C4 Shadow	04 - 05	700 HS	2046	
VT	750 CS ABS	13 - 14	828 HS	715 LS	
VT	750 RS	11 - 13	700 HS		
VT	750 S	11 - 12	700 HS		
XL	750 Transalp Left	23 - 24	859 HS	657 LS	
XL	750 Transalp Right	23 - 24	797 HS		
XLV	750 R	83 - 85	542 HF	2055	
XLV	750 R	86 - 88	572 HF	2055	
XRV	750 Africa Twin	90 - 92	593 HS	614 LS	
XRV	750 Africa Twin	93 - 03	694 HS*	614 LS	
PC	800 Pacific Coast	89 - 97	627 HS*	2046	
VFR	800	06 - 13	828 HS*	736 LS	

\* = 2 sets required / 2 jeux pour l'Avant.

Full compound selection, see under "Brake pad 1:1 Drawings" / Sélection complète de composés, voir "1:1 Schémas Plaquettes de frein".





**RECOMMENDED**

1xx - 2xx = Scooter Pads  
 5xx - 9xx = Street, Off Road & Racing Pads  
 2xxx = Brake Shoes



HONDA					
VFR	800 ABS	06 - 13	828 HS*	736 LS	
VFR	800 Crossrunner	11 - 13	828 HS*	862 LS	
VFR	800 F	14 - 16	809 HS*	862 LS	
VFR	800 F	17 - 19	947 HS*	862 LS	
VFR	800 FI	98 - 01	735 HS*	736 LS	
VFR	800 V-TEC, ABS	02 - 05	735 HS*	736 LS	
VFR	800 X Crossrunner	15 - 16	809 HS*	862 LS	
VFR	800 X Crossrunner	17 - 18	947 HS*	862 LS	
VT	800 C	88 - 94	542 HF	2046	
CB	900 C	82 - 82	542 HF*	542 HF	
CB	900 F	78 - 80	517 HF*	517 HF	
CB	900 F, F2	81 - 84	572 HF*	542 HF	
CB	900 Hornet	02 - 07	622 HS*	657 LS	
CBR	900 RR Fireblade	92 - 97	622 HS*	657 LS	
CBR	900 RR Fireblade	98 - 03	734 HS*	657 LS	
VFR	950 F, Carat	92 - 92	627 HS*	700 LS	
	1000 Pioneer	16 - 21	981 PSI*	975 PSI*	
	1000 Talon	21 - 21	981 PSI*	975 PSI*	
	1000 Talon R	19 - 21	981 PSI*	975 PSI*	
	1000 Talon X	19 - 21	981 PSI*	975 PSI*	
	1000 Talon X-4	20 - 20	981 PSI*	975 PSI*	
CB	1000 C	83 - 84	542 HF*	542 HF	
CB	1000 F (Big One)	93 - 97	622 HS*	657 LS	
CB	1000 Hornet	24 - 24	940 HS*	881 LS	
CB	1000 R	08 - 16	809 HS*	862 LS	
CB	1000 R	18 - 24	947 HS*	862 LS	
CB	1000 R ABS	08 - 16	828 HS*	862 LS	
CB	1000 R+ Neo Sports Cafe	18 - 18	947 HS*	862 LS	
CBF	1000	06 - 11	700 HS*	657 LS	
CBF	1000 ABS	06 - 11	828 HS*	828 LS	
CBF	1000 F ABS	15 - 18	828 HS*	657 LS	
CBF	1000 Limited Edition	09 - 14	700 HS*	657 LS	
CBF	1000 Limited Edition ABS	09 - 14	828 HS*	828 LS	
CBR	1000 F	87 - 88	600 HS*	542 LS	
CBR	1000 F	89 - 92	627 HS*	700 LS	
CBR	1000 F, FP	93 - 99	685 HS*	685 LS	
CBR	1000 RR Fireblade	04 - 05	809 HS*	657 LS	
CBR	1000 RR Fireblade	06 - 16	809 HS*	834 LS	
CBR	1000 RR Fireblade	17 - 22	947 HS*	834 LS	
CBR	1000 RR SP	14 - 22	901 HS*	834 LS	
CBR	1000 RR SP2	17 - 19	901 HS*	834 LS	
CBR	1000 RR-R Fireblade	20 - 23	985 HS*	730 LS	
CBR	1000 RR-R Fireblade	24 - 24	841 HS*	730 LS	
CBR	1000 RR-R SP Fireblade	20 - 21	901 HS*	730 LS	
CBR	1000 RR-R SP Fireblade	22 - 24	841 HS*	730 LS	
CBX	1000	78 - 80	517 HF*	517 HF	
CBX	1000	81 - 82	572 HF*	542 HF	
CRF	1000 L Africa Twin	16 - 19	940 HS*	657 LS	
CRF	1000 L Africa Twin (Parking Brake)	16 - 19		879 HF	
CRF	1000 L Africa Twin Adventure Sports	18 - 19	940 HS*	657 LS	
CRF	1000 L Africa Twin Adventure Sports (Parking Brake)	18 - 19		879 HF	
GL	1000 Gold Wing	81 - 81	517 HF*	517 HF	
GL	1000 Gr. Tour. Gold Wing	81 - 82	517 HF*	517 HF	
GL	1000 K1, K2 Gold Wing	75 - 77	508 HF*	509 HF	
GL	1000 K3 Gold Wing	78 - 79	517 HF*	509 HF	
RC213V-S	1000	16 - 18	901 HS*	730 LS	
VF	1000 F, FI	84 - 86	542 HF*	542 HF	
VF	1000 FI Bol d'Or	85 - 85	542 HF*	542 HF	
VF	1000 R	84 - 87	542 HF*	542 HF	
VFR	1000	89 - 89	627 HS*	700 LS	
VT	1000 C	88 - 88	542 HF	2046	
VTR	1000 F Firestorm	97 - 07	622 HS*	657 LS	
VTR	1000 SP-1, SP-2	00 - 06	734 HS*	657 LS	
XL	1000 Varadero	99 - 99	735 HS*	736 LS	
XL	1000 Varadero	07 - 13	828 HS*	736 LS	
	(Linked brake system)	00 - 06	735 HS*	736 LS	
XL	1000 Varadero ABS	04 - 13	828 HS*	736 LS	
CB	1100	13 - 13	828 HS*	657 LS	



**RECOMMENDED**

1xx - 2xx = Scooter Pads  
 5xx - 9xx = Street, Off Road & Racing Pads  
 2xxx = Brake Shoes



HONDA					
CB	1100	14 - 21	734 HS*	657 LS	
CB	1100 EX	14 - 21	734 HS*	657 LS	
CB	1100 F	83 - 85	542 HF*	542 HF	
CB	1100 Hornet	99 - 99	735 HS*	736 LS	
CB	1100 R, RD	81 - 83	542 HF*	542 HF	
CB	1100 RS ABS	17 - 21	947 HS*	657 LS	
CB	1100 X-11	00 - 03	735 HS*	736 LS	
CBR	1100 XX Super Blackbird	96 - 07	735 HS*	736 LS	
CMX	1100 Rebel	21 - 22	947 HS	881 LS	
CRF	1100 L Africa Twin	20 - 24	940 HS*	657 LS	
CRF	1100 L Africa Twin Adventure Sports	20 - 24	940 HS*	657 LS	
GL	1100 -1, DLX Gold Wing	81 - 87	542 HF*	542 HF	
GL	1100 A Gold Wing	79 - 83	517 HF*	517 HF	
GL	1100 Gold Wing	82 - 83	572 HF*	542 HF	
NT	1100	22 - 24	940 HS*	657 LS	
ST	1100	90 - 02	627 HS*	654 LS	
ST	1100 A6 ABS-TCS-CBS	96 - 01	721 HS*	722 LS	
ST	1100 ABS-TCS	92 - 95	627 HS*	654 LS	
VF	1100 C	83 - 86	572 HF*	542 HF	
VF	1100 S	84 - 85	572 HF*	542 HF	
VT	1100 C Shadow	87 - 93	542 HF	2046	
VT	1100 C Shadow	94 - 96	627 HS*	2046	
VT	1100 C2 Shadow A.C.E.	95 - 04	627 HS	657 LS	
VT	1100 C2 Y	00 - 05	627 HS	657 LS	
VT	1100 C3 Shadow Aero	98 - 04	627 HS	657 LS	
VT	1100 T Shadow	98 - 04	627 HS*	657 LS	
GL	1200 A, I Gold Wing	84 - 86	572 HF*	542 HF	
GL	1200 DX Gold Wing	86 - 87	572 HF*	542 HF	
GL	1200 Gold Wing	84 - 86	572 HF*	542 HF	
VFR	1200 F	10 - 19	869 HS*	862 LS	
VFR	1200 F w/DCT	10 - 19	869 HS*	892 LS	
VFR	1200 F w/DCT (Parking Brake)	10 - 19		879 HF	
VFR	1200 XC Crosstourer	12 - 19	828 HS*	892 LS	
VFR	1200 XDC Crosstourer w/DCT	12 - 19	828 HS*	892 LS	
VFR	1200 XDC Crosstourer w/DCT (Parking Brake)	12 - 19		879 HF	
CB	1300	05 - 13	734 HS*	657 LS	
CB	1300 R	02 - 04	734 HS*	715 LS	
CB	1300 S	11 - 15	828 HS*	657 LS	
CB	1300 SF	98 - 00	676 HS*	715 LS	
CB	1300 X-4	97 - 03	622 HS*	715 LS	
CTX	1300	14 - 18	828 HS*	700 LS	
ST	1300 Pan European, ABS	02 - 07	735 HS*	722 LS	
ST	1300 Pan European, ABS	08 - 18	828 HS*	722 LS	
VT	1300 CX A Fury	10 - 22	627 HS	657 LS	
VT	1300 CXA A Fury ABS	10 - 22	828 HS	736 LS	
VTX	1300 C	04 - 09	627 HS	657 LS	
VTX	1300 S	03 - 07	627 HS	657 LS	
GL	1500 A, SE, I Gold Wing	94 - 99	647 HS*	542 LS	
GL	1500 F6 C Valkyrie	96 - 02	627 HS*	700 LS	
GL	1500 Gold Wing, Gold Wing SE	88 - 99	647 HS*	542 LS	
GLX	1500	88 - 99	647 HF*	542 HF	
GL	1800 Gold Wing	01 - 17	735 HS*	880 LS	
GL	1800 Gold Wing	18 - 24	952 HS*	953 LS	
GL	1800 Gold Wing (Parking Brake)	18 - 24		879 HF	
GL	1800 Gold Wing F6B	13 - 16	735 HS*	880 LS	
VTX	1800	01 - 12	735 HS*	736 LS	
<b>HOREX</b>					
	80 Rebell N	83 - 83	532 HF		
	80 Rebell T	86 - 86	506 HF*	506 HF	
	80 Sport L	86 - 86	506 HF*	506 HF	
	125 Imperator	96 - 96	506 HF		
	125 Regent	96 - 96	506 HF		
	560 E	86 - 88	506 HF*	506 HF	
	600 Columbus	87 - 88	506 HF*	506 HF	
VR6	1200	11 - 16	706 HS*	611 LS	
VR6	1200 Cafe Racer	17 - 23	841 HS*	730 LS	
VR6	1200 Classic	17 - 23	841 HS*	730 LS	
VR6	1200 Raw	23 - 23	841 HS*	730 LS	

\* = 2 sets required / 2 jeux pour l'Avant.

Full compound selection, see under "Brake pad 1:1 Drawings" / Sélection complète de composés, voir "1:1 Schémas Plaquettes de frein".

**RECOMMENDED**1xx - 2xx = Scooter Pads  
5xx - 9xx = Street, Off Road & Racing Pads  
2xxx = Brake Shoes

HRD				
	50 GS Enduro	00 - 02	652 HF	675 HF
	50 Sonic 2 Supermotard	00 - 02	148 HF	105 HF
	50 Sonic 2 Trail	00 - 02	148 HF	105 HF
	125 Supermotard	00 - 02	652 HF	559 HF
	125 Trail	00 - 02	652 HF	559 HF
HUSABERG				
	all models	89 - 92	608 SI	586 SI
	all models	93 - 98	671 SI	586 SI
TE	125	13 - 13	671 SI	791 SI
FE	250	13 - 13	671 SI	791 SI
TE	250	11 - 13	671 SI	791 SI
TE	300	11 - 13	671 SI	791 SI
	350	91 - 92	608 SI	586 SI
FE	350	13 - 13	671 SI	791 SI
FE	390	10 - 13	671 SI	791 SI
FC	400	99 - 02	671 RSI	675 RSI
FE	400 ,s,e	99 - 03	671 SI	675 SI
FS	400 e, c	01 - 03	631 RSI	675 RSI
FC	450	03 - 08	671 RSI	675 RSI
FE	450	09 - 13	671 SI	791 SI
FE	450 e	04 - 08	671 SI	675 SI
FS	450 c	06 - 08	842 RSI	675 RSI
FS	450 e, c	03 - 05	631 RSI	675 RSI
FX	450 e	03 - 08	671 RSI	675 RSI
FC	470	01 - 02	671 RSI	675 RSI
FX	470 e	01 - 02	671 RSI	675 RSI
	500	91 - 98	608 SI	586 SI
	501 Enduro	91 - 94	608 SI	586 SI
FC	501	99 - 01	671 RSI	675 RSI
FE	501	13 - 13	671 SI	791 SI
FE	501 ,S,E	99 - 04	671 SI	675 SI
FC	550	01 - 05	671 RSI	675 RSI
FE	550 e	04 - 08	671 SI	675 SI
FE	570	09 - 13	671 SI	791 SI
	600 Enduro	91 - 94	608 SI	586 SI
FC	600	99 - 01	671 RSI	675 RSI
FE	600 , s, e	99 - 02	671 SI	675 SI
FE	650 e	01 - 08	671 SI	675 SI
FS	650 e, c	01 - 05	631 RSI	675 RSI
FS	650 e, c	06 - 08	842 RSI	675 RSI
FX	650 e	01 - 05	671 RSI	675 RSI

HUSQVARNA				
	all models	72 - 79	2116	2116
	all models	87 - 88		2116
	all models CR,TC,TE,WR	92 - 94	611 SI	536 SI
	all models TE,TC,WR,CR,AE	89 - 89	608 SI	2116
	all rear drum models	86 - 86		2117
EE	5	19 - 24	794 RSI	794 RSI
	50 Husky Boy J, R, S	01 - 10	559 RSI	
	50 Racing	98 - 98	105 HF	
CR	50 Junior	06 - 06	803 RSI	
CR	50 Pro Senior	06 - 06	803 RSI	794 RSI
CR	50 Senior	06 - 06	803 RSI	794 RSI
SM	50	02 - 02	148 HF	105 HF
SM	50	10 - 12	803 RSI	794 RSI
TC	50	17 - 24	794 RSI	794 RSI
TC	50 Mini	22 - 24	794 RSI	794 RSI
WR	50	02 - 02	148 HF	105 HF
WRS	50	98 - 98	105 HF	2181
CR	65	12 - 13	783 RSI	872 RSI
TC	65	17 - 22	783 RSI	783 RSI
TC	65	23 - 24	791 RSI	791 RSI
TC	85	14 - 20	885 RSI	872 RSI
TC	85	21 - 24	671 RSI	791 RSI
	125 Svartpilen	21 - 23	877 HS	675 LS
CR	125	83 - 84	2118	2116
CR	125	85 - 90	519 SI	2117
CR	125	96 - 04	671 RSI	675 RSI
CR	125	05 - 13	671 RSI	791 RSI
CR/RL	125	81 - 82	2117	2116

**RECOMMENDED**1xx - 2xx = Scooter Pads  
5xx - 9xx = Street, Off Road & Racing Pads  
2xxx = Brake Shoes

HUSQVARNA				
CR/WR	125	91 - 91	608 SI	692 SI
CX	125	84 - 85	519 SI	
SM	125 S	09 - 13	671 HF	675 HF
SM	125 S 4T	11 - 13	671 HF	675 HF
SM	125 Supermotard, S	99 - 13	671 HF	675 HF
TC	125	14 - 24	671 RSI	791 RSI
TE	125	14 - 16	671 SI	791 SI
TE	125 4T	11 - 13	671 HF	675 HF
TX	125	17 - 19	671 SI	791 SI
WR	125	80 - 80	2117	2116
WR	125	85 - 90	608 SI	2117
WR	125	96 - 13	671 SI	675 SI
WR/XC	125	82 - 82	2117	2117
WR/XC	125	83 - 84	2118	2117
WRE	125	96 - 13	671 SI	675 SI
WRK	125	90 - 90	608 SI	586 SI
XC	125	85 - 85		2116
TE	150 i	20 - 23	671 SI	791 SI
	200 Prof	86 - 86	519 SI*	519 SI
CR	240	84 - 85	519 SI	
WR	240	87 - 91	608 SI	692 SI
WRK	240	90 - 90	608 SI	586 SI
CR	250	81 - 82	2117	2116
CR	250	83 - 84	2118	2116
CR	250	85 - 87	519 SI	2117
CR	250	91 - 91	608 SI	692 SI
CR	250	96 - 04	671 RSI	675 RSI
CR	250	05 - 05	671 RSI	791 RSI
CX	250	84 - 85	519 SI	
FC	250	14 - 24	671 RSI	791 RSI
FE	250	14 - 23	671 SI	791 SI
TC	250	02 - 03	671 RSI	675 RSI
TC	250	04 - 24	671 RSI	791 RSI
TE	250	02 - 13	671 SI	675 SI
TE	250	14 - 18	671 SI	791 SI
TE	250 4T	10 - 13	671 SI	791 SI
TE	250 i	20 - 23	671 SI	791 SI
WR	250	96 - 13	671 SI	675 SI
WR/OR	250	80 - 80	2117	2116
WR/XC	250	81 - 82	2117	2117
WR/XC	250	83 - 84	2118	2117
WR/XC	250	87 - 90	608 SI	
WR	260	90 - 93	608 SI	692 SI
TC	300	14 - 15	671 RSI	791 RSI
TE	300	14 - 19	671 SI	791 SI
TE	300 i	18 - 23	671 SI	791 SI
TE	300 Pro	24 - 24	671 SI	791 SI
WR	300	09 - 13	671 SI	791 SI
TE	310 4T	10 - 13	671 SI	791 SI
FC	350	14 - 24	671 RSI	791 RSI
FE	350	14 - 23	671 SI	791 SI
FE	350 Pro	24 - 24	671 SI	791 SI
TE	350	96 - 13	671 SI	675 SI
TE	350 Enduro	90 - 90	608 SI	586 SI
WR	360	98 - 13	671 SI	675 SI
WR/OR	390	80 - 80	2117	2116
WR/XC	390	82 - 82	2117	2117
	400 Enduro	85 - 88	519 SI	2117
SM	400 R	02 - 02	566 HF	675 HF
TE	400	01 - 13	671 SI	675 SI
WR	400	87 - 88	608 SI	2117
WRX	400	85 - 85	2118	2116
	401 Svartpilen	17 - 23	877 HS	675 LS
	401 Vitpilen	17 - 23	877 HS	675 LS
TE	410	96 - 13	671 SI	675 SI
	430 Auto	87 - 87	608 SI	2117
	430 Enduro	85 - 88	519 SI	2116
CR	430	82 - 82	2117	2116
CR	430	87 - 89	608 SI	2117
CR/WR/CS	430	81 - 81	2117	2117
WR	430	87 - 89	608 SI	2116
XC	430	87 - 88	608 SI	2117

\* = 2 sets required / 2 jeux pour l'Avant.

Full compound selection, see under "Brake pad 1:1 Drawings" / Sélection complète de composés, voir "1:1 Schémas Plaquettes de frein".

**RECOMMENDED**

 1xx - 2xx = Scooter Pads  
 5xx - 9xx = Street, Off Road & Racing Pads  
 2xxx = Brake Shoes

**HUSQVARNA**

SMR	449	11 - 13	762 RST	791 RSI
TC	449	11 - 13	671 RSI	791 RSI
TE	449	11 - 13	671 SI	791 SI
FC	450	14 - 24	671 RSI	791 RSI
FE	450	14 - 23	671 SI	791 SI
FR	450 Rally	22 - 23	674 SI	791 SI
FS	450	15 - 22	841 RST	791 RSI
FX	450	17 - 20	671 SI	791 SI
SM	450 R	03 - 04	566 HF	675 HF
SM	450 R	05 - 05	762 RST	675 RSI
SM	450 R	06 - 13	762 RST	791 RSI
SM	450 RR	06 - 10	762 RST	791 RSI
TC	450	02 - 03	671 RSI	675 RSI
TC	450	04 - 10	671 RSI	791 RSI
TE	450	02 - 10	671 SI	675 SI
TE	450	14 - 14	671 SI	791 SI
CR	500	83 - 84	2118	2116
CR	500	86 - 87	519 SI	2117
CX/CR	500	84 - 85	519 SI	2116
TC	500	86 - 86	519 SI	2117
WR/XC/AE	500	83 - 84	2118	2117
XC	500	87 - 88	608 SI	2117
FE	501	14 - 23	671 SI	791 SI
	504	83 - 83	519 SI	2117
	510	87 - 89	608 SI	2117
	510	90 - 90	608 SI	586 SI
SM	510 Centennial	06 - 06	762 RST	791 RSI
SM	510 R	05 - 05	762 RST	675 RSI
SM	510 R	06 - 10	762 RST	791 RSI
TC	510	02 - 03	671 RSI	675 RSI
TC	510	04 - 10	671 RSI	791 RSI
TE	510	86 - 87	519 SI	2117
TE	510	02 - 10	671 SI	675 SI
TE	510 Centennial	04 - 05	671 SI	675 SI
SMR	511	11 - 13	762 RST	791 RSI
TE	511	11 - 14	671 SI	791 SI
	570 Nox	01 - 03	706 HF	675 HF
SM	570 R	01 - 08	566 HF	675 HF
TC	570	01 - 13	671 RSI	675 RSI
TE	570	01 - 13	671 SI	675 SI
LT	610	00 - 02	706 HF	675 HF
SM	610 ie	07 - 10	762 RST	791 RSI
SM	610 Super Motard, S	98 - 00	706 HF	675 HF
TC	610	96 - 13	671 RSI	675 RSI
TC	610 Cross	91 - 91	608 SI	692 SI
TE	610	91 - 95	608 SI	692 SI
TE	610 Rally	96 - 13	671 RSI	675 RSI
SM	630	10 - 10	762 HS	791 HF
SMR	630	04 - 08	706 RST	675 RSI
TE	630	10 - 13	671 HS	791 HF
TE	630	14 - 14	671 SI	791 SI
STR	650 CRC	07 - 07	762 HF	791 HF
TR	650 Strada	13 - 13	674 HS	675 LS
TR	650 Terra	13 - 13	674 HS	675 LS
	701 Enduro LR	20 - 20	674 HS	675 LS
	701 Svartpilen	18 - 19	706 HS	675 LS
	701 Vitpilen	18 - 20	706 HS	675 LS
FE	701 Enduro	17 - 20	674 HS	675 LS
SM	701 Supermoto	15 - 20	762 HS	675 LS
	900 Nuda	12 - 13	706 HS*	675 LS
	900 Nuda R, ABS	12 - 13	841 HS*	675 LS
	901 Norden	22 - 24	706 HS*	671 LS

**HYOSUNG**

	50 Avanti	99 - 02	101 HF	
	50 Rush	97 - 01	101 HF	
	50 Sense	98 - 07	101 HF	
	50 Super Cab	95 - 98	101 HF	
	50 Super Cab Plus	98 - 98	101 HF	
SB	50	00 - 03	101 HF	
SB	50 P	00 - 03	101 HF	
SD	50	00 - 06	101 HF	

**RECOMMENDED**

 1xx - 2xx = Scooter Pads  
 5xx - 9xx = Street, Off Road & Racing Pads  
 2xxx = Brake Shoes

**HYOSUNG**

SF	50	99 - 06	101 HF	
	100 Cab	98 - 01	101 HF	
EZ	100	00 - 05	101 HF	
	110 Midas Plus	98 - 04	101 HF	2015
FX	110	02 - 04	101 HF	2015
KR	110 Master	04 - 05	101 HF	2015
	125 Aquila	00 - 04	611 HF	
	125 Boomer	03 - 03	123 CT	103 CT
	125 Cruise II	99 - 06	524 HF	
	125 Cruise II Classic	99 - 06	524 HF	
	125 Cruiser	92 - 06	524 HF	
	125 Exceed	02 - 06	123 CT	103 CT
	125 GA-4	99 - 99	557 HF	
	125 Grand Prix	98 - 04	123 CT	
	125 Grand Prix Plus	02 - 05	551 HF	
	125 Hyper	99 - 09	123 CT	
	125 V2	99 - 11	627 HF	
GA	125	98 - 06	524 HF	
GA	125 F	00 - 06	524 HF	
GD	125 EXIV	12 - 16	734 HF	544 HF
GF	125	98 - 04	524 HF	
GPS	125 D	00 - 03	123 CT	
GS	125	99 - 99	524 HF	
GT	125	07 - 10	814 HF*	814 HF
GT	125 Comet	02 - 03	551 HF	
GT	125 Comet	04 - 06	814 HF	814 HF
GT	125 Naked	13 - 13	814 HF*	814 HF
GT	125 R Supersport	07 - 16	814 HF*	814 HF
GV	125 Aguila	02 - 04	551 HF	
GV	125 Aguila	05 - 11	814 HF	
RT	125 Karion	02 - 06	551 HF	
RT	125 Karion	07 - 09	814 HF*	814 HF
RX	125	00 - 07	551 HF	
RX	125 SM	07 - 11	814 HF*	814 HF
TN	125	92 - 95	524 HF	
XRX	125	07 - 09	814 HF*	814 HF
XRX	125 Offroad	99 - 06	551 HF	
	150 Exceed	02 - 04	123 CT	103 CT
	150 Grand Prix	98 - 01	123 CT	
	250 Aquila	00 - 09	627 HF	
GD	250 EXIV-R	15 - 17	734 HS	747 HF
GT	250 Comet	02 - 02	597 HS	556 LS
GT	250 Comet	03 - 08	814 HF	814 HF
GT	250 iR	13 - 14	814 HS*	814 LS
GT	250 iR	15 - 15	734 HS*	747 HF
GT	250 P	13 - 13	814 HF	814 HF
GT	250 R	07 - 12	814 HF*	814 HF
GV	250	02 - 09	551 HF	2014
GV	250	17 - 18	734 HS	638 HF
GA	300	98 - 01	557 HF	
GT	300 R	16 - 17	734 HS	747 HF
GV	300	16 - 17	734 HS	638 HF
TE	400	05 - 06	536 SI*	649 SI
XRX	400	05 - 08	551 HF	604 HF
RX	450 SM	08 - 11	762 HS	675 LS
TE	450	07 - 11	536 SI*	649 SI
	600 Comet	02 - 02	597 HS	556 LS
	600 Comet	03 - 03	551 HF*	
GT	650	04 - 12	814 HS*	814 LS
GT	650 i	13 - 13	734 HS*	814 LS
GT	650 i Naked	15 - 15	734 HS*	814 LS
GT	650 iR	13 - 14	734 HS*	814 LS
GT	650 iR	15 - 15	734 HS*	747 HF
GT	650 P	16 - 16	814 HS*	814 LS
GT	650 R	05 - 13	814 HS*	814 LS
GT	650 S	05 - 13	814 HS*	814 LS
GT	650 TTC	07 - 11	814 HS*	814 LS
GT	650 TTC / Custom Trendkiller	07 - 11	814 HS*	814 LS
GT	650 X	07 - 11	814 HS*	814 LS
GV	650 Aguila	04 - 05	551 HF*	769 HF
GV	650 Aguila	06 - 11	814 HS*	814 LS
ST	700	11 - 13	734 HS	814 LS

\* = 2 sets required / 2 jeux pour l'Avant.

Full compound selection, see under "Brake pad 1:1 Drawings" / Sélection complète de composés, voir "1:1 Schémas Plaquettes de frein".



**RECOMMENDED**1xx - 2xx = Scooter Pads  
5xx - 9xx = Street, Off Road & Racing Pads  
2xxx = Brake Shoes**HYOSUNG**

ST	700 i Deluxe	13 - 13	734 HS	814 LS
----	--------------	---------	--------	--------

**INDIAN**

	Chief	01 - 08	678 H.HS	678 H.LS
	Scout	01 - 08	678 H.HS	678 H.LS
	1000 Scout Sixty	16 - 16	929 H.HS	930 H.LS
	1000 Scout Sixty	17 - 18	674 H.HS	675 H.LS
	1130 Scout	15 - 16	929 H.HS	930 H.LS
	1200 Rogue	22 - 23	674 H.HS*	675 H.LS
	1200 Scout	17 - 23	674 H.HS	675 H.LS
	1200 Scout Bobber	17 - 23	674 H.HS	675 H.LS
FTR	1200	19 - 23	900 H.HS*	730 LS
FTR	1200 R carbon	21 - 23	900 H.HS*	730 LS
FTR	1200 Rally	19 - 23	900 H.HS*	730 LS
FTR	1200 S	19 - 23	900 H.HS*	730 LS
FTR	1200 S RR	20 - 23	900 H.HS*	730 LS
	1700 Chief Blackhawk	11 - 13	566 H.HS*	506 H.LS
	1700 Chief Bomber	10 - 13	566 H.HS*	506 H.LS
	1700 Chief Classic	10 - 13	566 H.HS*	506 H.LS
	1700 Chief Dark Horse	10 - 13	566 H.HS*	506 H.LS
	1700 Chief Deluxe	09 - 13	566 H.HS*	506 H.LS
	1700 Chief Roadmaster	09 - 13	566 H.HS*	506 H.LS
	1700 Chief Standard	09 - 13	566 H.HS*	506 H.LS
	1700 Chief Vintage	09 - 13	566 H.HS*	506 H.LS
	1768 Pursuit Dark Horse	22 - 23	900 H.HS*	700 H.LS
	1768 Pursuit Limited	22 - 23	900 H.HS*	700 H.LS
	1800 Challenger	20 - 23	900 H.HS*	700 H.LS
	1800 Challenger Dark Horse	20 - 23	900 H.HS*	700 H.LS
	1800 Challenger Elite	22 - 23	782 H.HS*	700 H.LS
	1800 Challenger Limited	20 - 23	900 H.HS*	700 H.LS
	1800 Chief	15 - 23	782 H.HS*	700 H.LS
	1800 Chief Bobber	22 - 23	782 H.HS	700 H.LS
	1800 Chief Bobber Dark Horse	22 - 23	782 H.HS	700 H.LS
	1800 Chief Classic	14 - 18	782 H.HS*	700 H.LS
	1800 Chief Dark Horse	15 - 23	782 H.HS*	700 H.LS
	1800 Chief Vintage	14 - 19	782 H.HS*	700 H.LS
	1800 Chieftain	14 - 23	782 H.HS*	700 H.LS
	1800 Chieftain Classic	15 - 18	782 H.HS*	700 H.LS
	1800 Chieftain Dark Horse	15 - 23	782 H.HS*	700 H.LS
	1800 Chieftain Limited	15 - 23	782 H.HS*	700 H.LS
	1800 Roadmaster	15 - 23	782 H.HS*	700 H.LS
	1800 Roadmaster Classic	15 - 18	782 H.HS*	700 H.LS
	1800 Roadmaster Dark Horse	20 - 23	782 H.HS*	700 H.LS
	1800 Roadmaster Elite	15 - 21	782 H.HS*	700 H.LS
	1800 Roadmaster Limited	21 - 23	782 H.HS*	700 H.LS
	1800 Springfield	16 - 23	782 H.HS*	700 H.LS
	1800 Springfield Dark Horse	15 - 23	782 H.HS*	700 H.LS
	1800 Super Chief	22 - 23	782 H.HS	700 H.LS
	1800 Super Chief Limited	22 - 23	782 H.HS	700 H.LS

**ITALJET**

	50 AJP Caliper incl. pin/spring	90 - 19	188 HF	
	50 Bazooka	93 - 02	111 HF	
	50 Cruise	95 - 97	111 HF	
	50 Dragster	99 - 06	105 HF	105 HF
	50 Formula	94 - 00	117 HF	123 HF
	50 Formula Air	99 - 00	105 HF	
	50 Formula L.C.	98 - 00	105 HF	105 HF
	50 Jet-Set	02 - 03	167 HF	
	50 Pista 2	92 - 97	111 HF	
	50 Pit Jet	07 - 09	211 HF	211 HF
	50 Rollercraft	08 - 12	200 HF	119 HF
	50 Scoop	93 - 97	111 HF	
	50 Torpedo	98 - 99	105 HF	
	50 Torpedo 4T	01 - 03	105 HF	
	50 Yankee 8	94 - 02	111 HF	111 HF
SM	50	02 - 05	148 HF	
SX1	50	08 - 10	141 HF	
	80 Formula	94 - 97	117 HF	123 HF
	100 Millennium 2T	01 - 01	101 HF	
	100 Millennium 2T	01 - 01	167 HF	
	125 Amarcord	08 - 16	121 HF	

**RECOMMENDED**1xx - 2xx = Scooter Pads  
5xx - 9xx = Street, Off Road & Racing Pads  
2xxx = Brake Shoes**ITALJET**

	125 Dragster	99 - 03	105 CT	105 CT
	125 Dragster	20 - 23	151 CT	157 CT
	125 Formula	94 - 03	117 CT	123 CT
	125 Formula L.C.	99 - 03	105 CT	105 CT
	125 Jet-Set	02 - 03	167 CT	
	125 Jupiter	02 - 03	128 CT	105 CT
	125 Millennium	00 - 03	101 CT	
	125 Millennium	00 - 03	167 CT	
	125 Pit Jet	07 - 09	211 HF	211 HF
	125 Torpedo	99 - 06	105 CT	
	125 Torpedo	08 - 11	200 CT	119 CT
	125 Twin	98 - 01	105 CT	105 CT
SM	125	02 - 05	652 HF	
	150 Jet-Set	02 - 03	167 CT	
	150 Jupiter	02 - 03	128 CT	105 CT
	150 Millennium	00 - 03	101 CT	
	150 Millennium	00 - 03	167 CT	
	150 Torpedo	08 - 12	200 CT	119 CT
	150 Torpedo 4T	01 - 01	105 CT	
	180 Dragster	99 - 03	105 CT	105 CT
	200 Dragster	20 - 23	151 CT	157 CT
	250 Jupiter	01 - 03	128 CT	173 HF
	350	83 - 83	519 HF*	
	500 Dragster	23 - 23	841 HS*	730 LS
	650 Bazooka	06 - 06	814 HS*	814 LS
	650 Grifon	06 - 07	814 HS*	814 LS
	900 Grifon	00 - 00	566 HF	

**J. J. COBAS**

TR1	250	85 - 85	566 HF	559 HF
Trial	250	85 - 85	559 RSI	

**JAWA**

CZ	125 2T	95 - 00	506 HF	
CZ	125 MX	95 - 00	506 HF	
CZ	180	92 - 92	506 HF	
	300 Trail	93 - 93	506 HF	
	350	93 - 95	699 HF	

**JCM**

	125 Europa	89 - 89	559 RSI	559 RSI
	125 Oxygene	89 - 89	595 HF	
	125 SR	89 - 89	559 RSI	559 RSI
	125 Week-End	89 - 89	595 HF	
	233 Vega	88 - 88	595 HF	574 HF
	240 Enduro	91 - 91	595 HF	
	240 Europa	89 - 89	559 RSI	559 RSI
	240 Oxygene	89 - 89	595 HF	
	240 SR	89 - 89	559 RSI	559 RSI
	240 Week-End	89 - 89	595 HF	
	250 Trial	87 - 87	595 HF	
	250 Week-End	91 - 91	595 HF	
	325 Europa	89 - 89	559 RSI	574 RSI
	325 Oxygene	89 - 89	595 HF	
	325 SR	89 - 89	559 RSI	559 RSI
	325 Week-End	89 - 89	595 HF	
	333 Vega	87 - 88	595 HF	574 HF

**JIANSHE**

JS	125 3	02 - 02	691 HF	
----	-------	---------	--------	--

**JINCHENG**

JC	125 2A/3A	97 - 97	638 HF	
JC	125 2B	97 - 97	690 HF	
JC	125 7B	97 - 97	585 HF	
JC	150 T-D	06 - 09	691 HF	
JC	250	06 - 09	713 HF	

**JOHN DEERE**

HPX	350 Gator	10 - 14	908 SI*	908 SI*
	500 Buck Left	05 - 05	754 SI	767 SI
	500 Buck Right	05 - 05	767 SI	

\* = 2 sets required / 2 jeux pour l'Avant.

Full compound selection, see under "Brake pad 1:1 Drawings" / Sélection complète de composés, voir "1:1 Schémas Plaquettes de frein".



**RECOMMENDED**

1xx - 2xx = Scooter Pads  
 5xx - 9xx = Street, Off Road & Racing Pads  
 2xxx = Brake Shoes



JOHN DEERE				
	500 Buck EX, EXT Left	05 - 05	754 SI	767 SI
	500 Buck EX, EXT Right	05 - 05	767 SI	
	500 Trail Buck Left	05 - 05	754 SI	767 SI
	500 Trail Buck Right	05 - 05	767 SI	
XUV	625 Gator	11 - 11	912 ATS*	
	650 Trail Buck Left	05 - 05	754 SI	767 SI
	650 Trail Buck Right	05 - 05	767 SI	
	650 Trail Buck EX, EXT Left	05 - 05	754 SI	767 SI
	650 Trail Buck EX, EXT Right	05 - 05	767 SI	
XUV	825 Gator	11 - 11	912 ATS*	
XUV	855 D Gator	11 - 11	912 ATS*	
JOTAGAS				
JT	125	14 - 19	939 RSI	803 RSI
JT	250	14 - 19	939 RSI	803 RSI
JT	280	14 - 19	939 RSI	803 RSI
JT	300	14 - 19	939 RSI	803 RSI
KAWASAKI				
	Ninja e-1	24 - 24	638 HF	638 HF
Z	e-1	24 - 24	638 HF	638 HF
AE	50	81 - 82	2015	2015
AR	50	81 - 82	544 HF	2015
KMX	50	88 - 93	544 HF	2015
KSR	50 I (50)	90 - 91	544 HF	544 HF
KX	60	83 - 03	2093	2093
KX	65	00 - 24	752 RSI	536 RSI
AE	80	81 - 86	2015	2015
AR	80	81 - 82	544 HF	2015
KD	80	80 - 87	2015	2015
KD	80	88 - 90	544 HF	2015
KMX	80	87 - 92	548 HF	2015
KSR	80 II (80)	90 - 91	544 HF	544 HF
KX	80	79 - 82	2087	2087
KX	80	83 - 83	2092	2093
KX	80	84 - 87	544 SI	2093
KX	80	88 - 96	544 RSI	592 RSI
KX	80	97 - 00	726 RSI	592 RSI
KX	85	01 - 24	726 RSI	592 RSI
KX	85 II	01 - 24	726 RSI	592 RSI
KH	90	78 - 83	522 HF	
KC	100	80 - 83	2015	2015
KE	100	79 - 97	2015	2015
KH	100	76 - 77	2015	2015
KH	100	78 - 81	2014	2015
KH	100 EX	88 - 93	546 HF	2014
KH	100 EX, G	81 - 82	522 HF	2015
KH	100 GH	83 - 87	546 HF	2015
KM	100	78 - 81	2015	2015
KX	100	88 - 96	544 RSI	592 RSI
KX	100	97 - 21	726 RSI	592 RSI
KLF	110 Mojave	87 - 88	2015*	2183
KLX	110	02 - 24	2093	2015
	125 Ninja	19 - 24	638 HF	638 HF
AR	125	82 - 94	546 HF	2183
BN	125 Eliminator	98 - 99	536 HF	2183
BN	125 Eliminator A3	00 - 07	638 HF	2183
J	125	15 - 19	183 CT	204 CT
KDX	125	90 - 94	544 SI	632 SI
KE	125	76 - 85	2039	2183
KE	125	86 - 91	546 HF	2014
KH	125	77 - 80	516 HF	2025
KH	125	82 - 98	546 HF	2014
KLX	125	10 - 14	611 HF	536 HF
KLX	125 D-Tracker	10 - 14	611 HF	536 HF
KLX	125 L	03 - 06	702 SI	
KMX	125	86 - 86	544 HF	586 HF
KMX	125	87 - 02	548 HF	586 HF
KX	125	74 - 81	2039	2183
KX	125	82 - 82	544 SI	2183
KX	125	83 - 85	546 SI	2025
KX	125	86 - 86	546 RSI	586 RSI



**RECOMMENDED**

1xx - 2xx = Scooter Pads  
 5xx - 9xx = Street, Off Road & Racing Pads  
 2xxx = Brake Shoes



KAWASAKI				
KX	125	87 - 88	602 HF	586 SI
KX	125	89 - 93	611 RSI	632 RSI
KX	125	94 - 94	694 RSI	632 RSI
KX	125	95 - 08	694 RSI	604 RSI
Z	125	19 - 23	638 HF	638 HF
Z	125 Pro	17 - 22	925 HF	536 HF
ZL	125 Eliminator	97 - 99	544 HF	
KLX	140 , L	08 - 24	611 SI	592 SI
KLX	150 D-Tracker	16 - 18	611 HF	536 HF
KLX	150 L	14 - 15	611 HF	536 HF
KDX	175	80 - 82	2039	2183
KE	175	76 - 78	2039	2183
KE	175	79 - 83	2039	2056
KLF	185 Bayou	85 - 85		2038
KLF	185 Bayou	86 - 88	2040*	2038
KDX	200	83 - 85	2056	2025
KDX	200	93 - 93	611 SI	632 SI
KDX	200	94 - 99	694 SI	632 SI
KDX	200 C	86 - 88	546 SI	2025
KDX	200 SR	89 - 92	546 SI	632 SI
KMX	200	88 - 90	544 HF	586 HF
Z	200	77 - 81	516 HF	2014
Z	200	83 - 85	546 HF	2014
KDX	220 R	97 - 05	694 SI	632 SI
KLF	220 Bayou	88 - 02	2040*	2038
KLX	230	19 - 22	611 HF	536 HF
KLX	230 R	22 - 23	611 HF	536 HF
KLX	230 SE	22 - 22	611 HF	536 HF
	250 Estrella	92 - 99	546 HF	586 HF
BR	250	86 - 90	557 HF	2038
CS	250	86 - 90	557 HF	
EL	250	91 - 94	557 HF	2038
EL	250 Eliminator	88 - 89	557 HF	2038
EX	250 R Ninja	86 - 87	557 HF	557 HF
EX	250 R Ninja	88 - 07	597 HF	615 HF
EX	250 R Ninja	08 - 17	638 HS	638 LS
EX	250 R Ninja	18 - 20	955 HS	638 LS
EX	250 SL Ninja	15 - 17	638 HS	638 LS
GPX	250 R	88 - 91	597 HF*	615 HF
GPZ	250	83 - 85	557 HF*	2038
GPZ	250 Belt Drive	83 - 84	546 HF	2038
GPZ	250 R	86 - 87	557 HF	557 HF
KDX	250	80 - 82	2040	2016
KDX	250	83 - 84	2040	2183
KDX	250 SR	91 - 94	611 SI	632 SI
KH	250	76 - 80	510 HF	2088
KL	250	78 - 79	2040	2016
KL	250	80 - 84	2039	2056
KL	250 (KLR 250)	85 - 97	546 HF	2056
KL	250 Super Sherpa	00 - 02	726 SI	586 SI
KLF	250 Bayou	03 - 11	2040*	2038
KLR	250	84 - 05	546 HF	2038
KLT	250 Prairie	83 - 85	2015	2040
KLX	250	79 - 80	2039	2183
KLX	250	93 - 96	694 SI	632 SI
KLX	250	98 - 07	694 SI	604 SI
KLX	250	14 - 18	611 HF	604 HF
KLX	250 S	09 - 14	611 HF	604 HF
KLX	250 SF	09 - 10	611 HF	604 HF
KR	250	85 - 85	546 HF*	557 HF
KR-1	250 S	89 - 89	615 HF*	615 HF
KR-1	250 S	90 - 90	631 HF*	615 HF
KSF	250 Mojave	87 - 02	591 SI*	592 SI
KT	250 all models	75 - 80	2039	2183
KX	250	75 - 81	2040	2016
KX	250	82 - 82	544 SI	2183
KX	250	83 - 85	546 SI	2183
KX	250	86 - 86	546 RSI	586 RSI
KX	250	87 - 88	602 HF	586 SI
KX	250	89 - 93	611 RSI	632 RSI
KX	250	94 - 94	694 RSI	632 RSI
KX	250	95 - 08	694 RSI	604 RSI

\* = 2 sets required / 2 jeux pour l'Avant.

Full compound selection, see under "Brake pad 1:1 Drawings" / Sélection complète de composés, voir "1:1 Schémas Plaquettes de frein".

**RECOMMENDED**

1xx - 2xx = Scooter Pads  
5xx - 9xx = Street, Off Road & Racing Pads  
20xx = Brake Shoes



KAWASAKI					
KX	250	19 - 24	694 RSI	790 RSI	
KX	250 F	04 - 18	694 RSI	790 RSI	
KX	250 X	21 - 24	694 SI	790 SI	
KXF	250 Tecate	87 - 88	591 SI*	592 SI	
KXT	250 Tecate	84 - 84		544 HF	
KXT	250 Tecate	85 - 86	546 SI	586 SI	
KXT	250 Tecate	87 - 88	591 SI	592 SI	
LX	250 Eliminator, SE	90 - 95	557 HS		
SC	250 Epsilon	02 - 06	146 MS*	174 MS	
Z	250	78 - 80	510 HF	556 HF	
Z	250	80 - 83		2038	
Z	250	81 - 83		2183	
Z	250 Eliminator	88 - 88	557 HF	2183	
Z	250 J	81 - 85	540 HF*	556 HF	
Z	250 SL	15 - 17	638 HF	638 HF	
Z	250 T, Scorpion	89 - 89	546 HF	2038	
ZR	250 Balius	91 - 95	597 HF	586 HF	
ZX-25R	250	20 - 23	806 HS	657 LS	
ZXR	250	90 - 90	615 HS*	615 LS	
ZXR	250 R	89 - 89	615 HS*	615 LS	
ZZR	250	90 - 01	597 HS	586 LS	
EL	252	97 - 00	557 HS	2038	
EL	252	01 - 03	611 HS	2038	
EX	300 R Ninja, ABS	13 - 17	638 HS	638 LS	
J	300	14 - 19	183 MS	204 MS	
KAF	300 Mule 500	92 - 95	2053*		
KAF	300 Mule 550	03 - 05	2053*		
KEF	300 Lakota	95 - 04	591 SI*	592 SI	
KLE	300 Versys-X	17 - 23	627 HS	638 LS	
KLF	300 Bayou	86 - 87	2054*	2038*	
KLF	300 Bayou	88 - 04	546 SI*	2038*	
KLF	300 Bayou 4x4 Left	89 - 05	611 SI	2197	
KLF	300 Bayou 4x4 Right	89 - 05	638 SI		
KLX	300	96 - 07	694 HF	604 HF	
KLX	300	19 - 23	611 HF	604 HF	
KLX	300 R	97 - 07	694 SI	604 SI	
KVF	300 Brute Force	13 - 23	810 SI*	810 SI	
Z	300	15 - 16	638 HS	638 LS	
EX	305	83 - 83	557 HF	2038	
GPZ	305	81 - 96	546 HF*	2038	
Z	305	81 - 82	540 HF	2038	
Z	305	87 - 88	540 HF		
KLR	350	85 - 85	546 HF		
S2A	350	73 - 73	503 HF	2088	
KVF	360 Prairie 2x4, 4x4	03 - 08	536 SI*		
	400 Eliminator	94 - 95	597 HS	557 LS	
	400 Ninja R Left	11 - 11	705 HS	687 LS	
	400 Ninja R Right	11 - 11	704 HS		
EN	400 Twin	85 - 89	557 HF	2060	
EX	400 Ninja	18 - 23	955 HS*	638 LS	
EX	400 Ninja SE	18 - 23	955 HS*	638 LS	
EX-4	400	95 - 95	597 HF	586 HF	
FX	400 R	86 - 88	546 HF*	557 HF	
GPX	400	87 - 87	615 HF*	597 HF	
GPZ	400	83 - 84	539 HF*	540 HF	
GPZ	400	85 - 87	546 HF*	557 HF	
GPZ	400 R	89 - 89	615 HS*	597 LS	
GPZ	400 S	88 - 90	597 HF	2038	
KFX	400	02 - 05	592 SI*	649 SI	
KH	400	76 - 78	510 HF	2088	
KLE	400	91 - 94	597 HS	586 LS	
KLE	400 Vulcan	90 - 90	557 HS		
KLF	400 Bayou Left	93 - 99	611 SI	2197	
KLF	400 Bayou Right	93 - 99	638 SI		
KLX	400 R	03 - 04	694 SI	604 SI	
KLX	400 SR	03 - 04	694 HF	604 HF	
KVF	400 Prairie	97 - 98	536 SI*	2197	
KVF	400 Prairie 2x4	99 - 01	536 SI*		
KVF	400 Prairie 4x4	99 - 02	536 SI*		
LX	400 Eliminator, SE	90 - 90	546 HF*		
S3	400	74 - 75	503 HF		
S3A	400	74 - 75	503 HF		

**RECOMMENDED**

1xx - 2xx = Scooter Pads  
5xx - 9xx = Street, Off Road & Racing Pads  
20xx = Brake Shoes



KAWASAKI					
Z	400	78 - 78	522 HF	2038	
Z	400	79 - 79	510 HF	2038	
Z	400	19 - 24	955 HS*	638 LS*	
Z	400 C1	80 - 85	510 HF		
Z	400 D, S	76 - 77	518 HF	2038	
Z	400 Eliminator	88 - 88	557 HF	557 HF	
Z	400 F	84 - 86	546 HF	2038	
Z	400 J	80 - 85	539 HF*	2060	
Z	400 T (Belt Drive)	83 - 85	539 HF	2060	
ZR	400 F	83 - 84	546 HF	2038	
ZR	400 Xanthus (ZR 400D1)	92 - 95	615 HS*	586 LS	
ZR	400 Zephyr	97 - 01	631 HS*	687 LS	
ZRX	400	98 - 01	743 HS		
ZX	400	85 - 85	546 HF	557 HF	
ZX	400	86 - 87	557 HF*	557 HF	
ZX-4	400	88 - 89	615 HF*	615 HF	
ZX-4	400	90 - 90	631 HS*	556 LS	
ZX-4R	400	23 - 24	806 HS*	657 LS	
ZX-4R	400 SE	23 - 24	806 HS*	657 LS	
ZX-4RR	400	23 - 24	806 HS*	657 LS	
ZXR	400	89 - 90	631 HF*	556 HF	
ZXR	400	91 - 02	666 HS*	556 LS	
ZZR	400	90 - 94	631 HS*	597 LS	
KX	420	80 - 81	2040	2016	
Z	440 C	80 - 81	510 HF	2038	
Z	440 C, Twin	81 - 83	540 HF	2038	
Z	440 H	82 - 83	539 HF	540 HF	
Z	440 LTD	80 - 81	510 HF	2038	
Z	440 LTD	83 - 84	540 HF	2038	
EN	450	85 - 90	557 HF	2060	
KFX	450 Left	07 - 15	801 SI	592 SI	
KFX	450 Right	07 - 15	798 SI		
KLX	450 R	07 - 24	694 SI	790 SI	
KX	450	19 - 23	694 RSI	790 RSI	
KX	450	24 - 24	671 RSI	790 RSI	
KX	450 F	06 - 18	694 RSI	790 RSI	
KX	450 X	21 - 23	694 SI	790 SI	
KX	450 X	24 - 24	671 SI	790 SI	
Z	450 LTD	84 - 89	557 HF	2060	
	451 7 HEV	24 - 24	627 HS*	638 LS	
	451 Ninja 7 HEV	24 - 24	627 HS*	638 LS	
	500 Eliminator	24 - 24	955 HS	638 HF	
	500 Eliminator SE	24 - 24	955 HS	638 HF	
	500 Ninja	24 - 24	955 HS	638 HF	
	500 Ninja SE	24 - 24	955 HS	638 HF	
EN	500	90 - 04	557 HS	2060	
EN	500 Vulcan	96 - 97	557 HS	2060	
ER-5	500	97 - 00	597 HS	2038	
ER-5	500	01 - 07	705 HS	2038	
EX	500	87 - 89	597 HF	2038	
EX	500	90 - 93	597 HS	2038	
EX	500	94 - 96	615 HS	586 LS	
EX	500 Ninja	94 - 97	597 HS	586 LS	
GPX	500 R (Austria)	88 - 93	597 HF*	597 HF	
GPZ	500	93 - 94	631 HS	2038	
GPZ	500	95 - 96	546 HF*	586 HF	
GPZ	500	97 - 04	615 HS*	586 LS	
GPZ	500 R (Austria)	85 - 87	557 HF*	557 HF	
GPZ	500 S	87 - 87	557 HF	2038	
GPZ	500 S	88 - 88	546 HF	2038	
GPZ	500 S	89 - 92	546 HS*	557 LS	
GPZ	500 S (Austria)	87 - 93	597 HF	2038	
GPZ	500 S (Austria)	94 - 01	615 HS*	586 LS	
KH	500	76 - 79	510 HF		
KH	500 H1	74 - 75	503 HF		
KL	500 Tengai (Austria)	89 - 91	597 HS	586 LS	
KLE	500	91 - 07	597 HS	586 LS	
KLR	500 (Austria)	87 - 88	602 HF	586 HF	
KX	500	83 - 85	546 SI	2183	
KX	500	86 - 86	546 RSI	586 RSI	
KX	500	87 - 88	602 HF	586 SI	
KX	500	89 - 93	611 RSI	632 RSI	

\* = 2 sets required / 2 jeux pour l'Avant.

Full compound selection, see under "Brake pad 1:1 Drawings" / Sélection complète de composés, voir "1:1 Schémas Plaquettes de frein".





**RECOMMENDED**

1xx - 2xx = Scooter Pads  
5xx - 9xx = Street, Off Road & Racing Pads  
2xxx = Brake Shoes



KAWASAKI					
KX	500	94 - 95	694 RSI	632 RSI	
KX	500	96 - 04	694 RSI	604 RSI	
Z	500	79 - 80	510 HF*	512 HF	
Z	500	81 - 83	539 HF	540 HF	
Z	500	24 - 24	955 HS	638 HF	
Z	500 SE	24 - 24	955 HS	638 HF	
ZL	500 (Austria)	85 - 90	557 HF	2060	
ZR	500 (Z 500 F)	83 - 87	546 HF	2038	
ZZR	500 (Austria)	90 - 92	631 HS*	597 LS	
ZZR	500 (Austria)	93 - 98	631 HS*	687 LS	
GPZ	550	84 - 87	557 HF*	557 HF	
GT	550	85 - 01	557 HF*	2060	
KX	550 A	83 - 83	546 SI		
Z	550	80 - 80	510 HF		
Z	550	81 - 84	540 HF	2060	
Z	550 C3, LTD	82 - 84	540 HF	2060	
Z	550 E, LTD	81 - 84	539 HF*	540 HF	
Z	550 F	83 - 84	546 HF*	2038	
Z	550 F	85 - 88	557 HF*	2038	
Z	550 GP	81 - 83	539 HF	540 HF	
Z	550 GT	83 - 01	546 HF*	2060	
Z	550 GT, LTD	82 - 85	540 HF	2060	
Z	550 LTD	81 - 85	539 HF	2060	
Z	550 M1, LTD	83 - 86	540 HF	2060	
ZR	550 A1, GP	83 - 84	546 HF*	2038	
ZR	550 Zephyr	90 - 92	597 HS*	615 LS	
ZR	550 Zephyr	93 - 99	597 HS*	687 LS	
ZR	550 Zephyr (D) from VIN B024010-	93 - 01	615 HS*	687 LS	
ZX	550	84 - 89	557 HF*	557 HF	
	600 R, Ninja	89 - 96	631 HF*	556 HF	
GPX	600 R	88 - 93	597 HF*	597 HF	
GPX	600 R	94 - 96	597 HS*	597 LS	
GPZ	600 R	85 - 89	557 HF*	557 HF	
GPZ	600 R	94 - 94	597 HS*	597 LS	
KL	600	84 - 86	546 HF	2183	
KLR	600	84 - 86	546 HF	2183	
KLR	600 E	85 - 94	546 HF	2183	
Z	600 GP	83 - 89	557 HF*	557 HF	
ZL	600	85 - 91	557 HF	2060	
ZL	600 B2 Eliminator	95 - 98	597 HS	2060	
ZX	600 Ninja	85 - 87	557 HF*	557 HF	
ZX	600 Ninja	90 - 93	631 HS*	597 LS	
ZX	600 Ninja R	88 - 97	597 HS*	597 LS	
ZX-6R	600 (Ninja ZX6)	93 - 97	631 HS*	687 LS	
ZX-6R	600 (Ninja ZX6R)	95 - 97	631 HS*	687 LS	
ZX-6R	600 (ZX6)	90 - 93	631 HS*	597 LS	
ZX-6R	600 Ninja	98 - 01	686 HS*	687 LS	
ZX-6R	600 Ninja	07 - 17	838 HS*	687 LS	
ZX-6RR	600 Ninja	03 - 06	788 HS*	687 LS	
ZZR	600	90 - 92	631 HS*	597 LS	
ZZR	600	93 - 07	631 HS*	687 LS	
ZX-6R	636 Ninja	02 - 02	686 HS*	687 LS	
ZX-6R	636 Ninja	03 - 06	788 HS*	687 LS	
ZX-6R	636 Ninja	13 - 18	894 HS*	834 LS	
ZX-6R	636 Ninja ABS	13 - 24	894 HS*	834 LS	
EN	650 Vulcan S	15 - 24	735 HS	657 LS	
EN	650 Vulcan S Cafe	17 - 19	735 HS	657 LS	
EN	650 Vulcan S SE	17 - 18	735 HS	657 LS	
ER-6f	650 Left	06 - 16	705 HS	687 LS	
ER-6f	650 Right	06 - 16	704 HS		
ER-6n	650 Left	06 - 16	705 HS	687 LS	
ER-6n	650 Right	06 - 16	704 HS		
EX	650 Ninja ABS	17 - 23	627 HS*	657 LS	
EX	650 Ninja Performance ABS	17 - 23	627 HS*	657 LS	
EX	650 Ninja Tourer ABS	17 - 23	627 HS*	657 LS	
KLE	650 Versys Left	07 - 14	705 HS	687 LS	
KLE	650 Versys Right	07 - 14	704 HS		
KLE	650 Versys	15 - 15	627 HS*	881 LS	
KLE	650 Versys	16 - 24	627 HS*	657 LS	
KLE	650 Versys ABS Left	07 - 14	705 HS	687 LS	
KLE	650 Versys ABS Right	07 - 14	704 HS		
KLE	650 Versys ABS	15 - 15	627 HS*	881 LS	



**RECOMMENDED**

1xx - 2xx = Scooter Pads  
5xx - 9xx = Street, Off Road & Racing Pads  
2xxx = Brake Shoes



KAWASAKI					
KLE	650 Versys ABS	16 - 23	627 HS*	657 LS	
KLE	650 Versys LT	15 - 16	627 HS*	881 LS	
KLR	650	87 - 94	602 HF	586 SI	
KLR	650	95 - 04	705 HS	586 LS	
KLR	650	08 - 18	611 HS	638 LS	
KLR	650 Tengai	89 - 92	597 HS	586 LS	
KLX	650	93 - 96	694 SI	632 SI	
KLX	650 R	93 - 95	694 SI	632 SI	
KLX	650 R D1	96 - 96	694 SI	604 SI	
KVF	650 Brute Force 4x4 Left	05 - 11	801 SI		
KVF	650 Brute Force 4x4 Right	05 - 11	798 SI		
KVF	650 Brute Force 4x4i Left	05 - 11	611 SI		
KVF	650 Brute Force 4x4i Right	05 - 11	638 SI		
KVF	650 Prairie Left	01 - 03	801 SI		
KVF	650 Prairie Right	01 - 03	798 SI		
W	650	99 - 05	704 HF	2038	
Z	650	78 - 80	510 HF*	512 HF	
Z	650	81 - 84	539 HF	2060	
Z	650 ABS	17 - 24	627 HS*	657 LS	
Z	650 CSR	81 - 82	540 HF		
Z	650 F	81 - 84	539 HF*	2060	
Z	650 RS	22 - 24	627 HS*	657 LS	
KFX	700 V-Force Left	04 - 13	801 SI		
KFX	700 V-Force Right	04 - 13	798 SI		
KSV	700 V-Force Left	04 - 11	801 SI		
KSV	700 V-Force Right	04 - 11	798 SI		
KVF	700 Prairie Left	04 - 13	801 SI		
KVF	700 Prairie Right	04 - 13	798 SI		
VN	700 Vulcan	85 - 85	557 HF*	2060	
Z	700	83 - 88	539 HF*	540 HF	
ZN	700	84 - 89	557 HF*	557 HF	
	750 Vulcan	93 - 94	557 HF	2060	
GPX	750 R	87 - 89	597 HF*	597 HF	
GPZ	750	82 - 82	539 HF	540 HF	
GPZ	750	83 - 87	557 HF*	557 HF	
GPZ	750 R	85 - 86	557 HF*	557 HF	
GPZ	750 T	83 - 85	557 HF*	557 HF	
GT	750	86 - 91	557 HF*	557 HF	
KRF	750 Teryx 4x4 Left	08 - 13	611 SI		
KRF	750 Teryx 4x4 Right	08 - 13	638 SI		
KVF	750 Brute Force 4x4i Left	05 - 15	611 SI		
KVF	750 Brute Force 4x4i Right	05 - 15	638 SI		
VN	750 Twin	88 - 88	557 HS*		
VN	750 Vulcan	86 - 94	557 HF*	2060	
VZ	750 Twin	88 - 88	557 HF	2060	
Z	750	83 - 83	557 HF*	2060	
Z	750	84 - 86	539 HF*	540 HF	
Z	750 Left	04 - 06	705 HS	687 LS	
Z	750 Right	04 - 06	704 HS		
Z	750 ,ABS	07 - 12	627 HS*	657 LS	
Z	750 B	76 - 79	510 HF	514 HF	
Z	750 E	80 - 81	539 HF*	540 HF	
Z	750 Eliminator	88 - 88	557 HF*	557 HF	
Z	750 GT	82 - 85	539 HF*	540 HF	
Z	750 H	72 - 75	503 HF	2091	
Z	750 L	80 - 83	539 HF*	540 HF	
Z	750 L	84 - 87	540 HF*	540 HF	
Z	750 LTD	80 - 80	510 HF*	2060	
Z	750 LTD	81 - 81	539 HF*	540 HF	
Z	750 LTD Belt Drive	83 - 85	539 HF*	540 HF	
Z	750 LTD Twin	82 - 82	539 HF*	540 HF	
Z	750 LTD Twin	83 - 85	557 HF	557 HF	
Z	750 M1	82 - 85	540 HF	2060	
Z	750 N, LTD	82 - 85	539 HF*	540 HF	
Z	750 R	11 - 12	838 HS*	881 LS	
Z	750 R1	82 - 82	540 HF*	540 HF	
Z	750 S Left	05 - 06	705 HS	687 LS	
Z	750 S Right	05 - 06	704 HS		
Z	750 Sp.	83 - 84	539 HF*	540 HF	
Z	750 Turbo	84 - 86	557 HF*	557 HF	
ZR	750 Zephyr	91 - 95	597 HS*	597 LS	
ZR	750 Zephyr Left	96 - 97	705 HS	597 LS	

\* = 2 sets required / 2 jeux pour l'Avant.

Full compound selection, see under "Brake pad 1:1 Drawings" / Sélection complète de composés, voir "1:1 Schémas Plaquettes de frein".

**RECOMMENDED**1xx - 2xx = Scooter Pads  
5xx - 9xx = Street, Off Road & Racing Pads  
20xx = Brake Shoes**KAWASAKI**

ZR	750 Zephyr Right	96 - 97	704 HS	
ZR-7	750 Left	99 - 04	705 HS	704 LS
ZR-7	750 Right	99 - 04	704 HS	
ZR-7S	750 Left	01 - 04	705 HS	704 LS
ZR-7S	750 Right	01 - 04	704 HS	
ZX	750 E, GP	83 - 85	557 HF*	557 HF
ZX-7R	750 Ninja	89 - 95	631 HS*	556 LS
ZX-7R	750 Ninja	96 - 03	686 HS*	556 LS
ZX-7RR	750 Ninja	96 - 02	676 HS*	715 LS
ZXR	750 R	89 - 95	631 HS*	556 LS
	800 Mule Pro FX Left	15 - 17	611 SI	
	800 Mule Pro FX Right	15 - 17	638 SI	
KRF	800 Teryx BEF/CEF/DEF Left	14 - 17	611 SI	
KRF	800 Teryx BEF/CEF/DEF Right	14 - 17	638 SI	
KRT	800 Teryx 4 BEF/CEF/DEF Left	14 - 17	611 SI	
KRT	800 Teryx 4 BEF/CEF/DEF Right	14 - 17	638 SI	
VN	800 Classic	98 - 99	705 HS	2060
VN	800 Drifter	99 - 02	705 HS	704 LS
VN	800 Vulcan, Classic	95 - 97	557 HS	2060
W	800	11 - 16	704 HS	
W	800	20 - 24	704 HS	638 LS
W	800 Cafe	19 - 22	704 HS	638 LS
W	800 Street	19 - 22	704 HS	638 LS
Z	800	13 - 16	782 HS*	881 LS
Z	800 ABS	13 - 16	782 HS*	881 LS
Z	800 e	13 - 16	627 HS*	881 LS
Z	800 e ABS	13 - 16	782 HS*	881 LS
GPZ	900 R Ninja	84 - 89	557 HF*	557 HF
GPZ	900 R Ninja	90 - 96	631 HS*	597 LS
VN	900 Classic	06 - 16	705 HS	886 LS
VN	900 Classic SE	11 - 16	705 HS	886 LS
VN	900 Custom	07 - 16	705 HS	886 LS
Z	900	17 - 24	782 HS*	881 LS
Z	900 A	76 - 77	510 HF*	2091
Z	900 Performance	22 - 23	782 HS*	881 LS
Z	900 RS	18 - 24	806 HS*	657 LS
Z	900 RS Cafe	18 - 21	806 HS*	657 LS
Z	900 RS SE	22 - 24	900 HS*	657 LS
Z	900 SE	22 - 24	900 HS*	881 LS
Z1	900 Z1 A, Z1 B	73 - 75	503 HF	2091
ZL	900 Eliminator	85 - 86	557 HF*	557 HF
ZX	900	83 - 84	557 HF*	557 HF
ZX-9R	900 Ninja	94 - 95	631 HS*	687 LS
ZX-9R	900 Ninja	96 - 01	686 HS*	687 LS
ZX-9R	900 Ninja	02 - 03	782 HS*	687 LS
	1000 Ninja SX	20 - 24	806 HS*	687 LS
GPZ	1000 RX	86 - 88	557 HS*	557 LS
GTR	1000	86 - 93	557 HS*	557 LS
GTR	1000	94 - 06	597 HS*	557 LS
KLE	1000 Versys	12 - 18	631 HS*	657 LS
KLE	1000 Versys	19 - 24	806 HS*	657 LS
KLE	1000 Versys ABS	15 - 18	631 HS*	657 LS
KLE	1000 Versys ABS	19 - 24	806 HS*	657 LS
KLE	1000 Versys LT	15 - 16	631 HS*	657 LS
KLE	1000 Versys S	21 - 24	806 HS*	657 LS
KLE	1000 Versys SE	19 - 24	806 HS*	657 LS
KLK	1000 Left	04 - 07	705 HS	657 LS
KLK	1000 Right	04 - 07	704 HS	
Z	1000	76 - 81	510 HF*	512 HF
Z	1000	03 - 06	782 HS*	687 LS
Z	1000	07 - 09	838 HS*	657 LS
Z	1000	10 - 16	806 HS*	687 LS
Z	1000 ABS	15 - 19	806 HS*	687 LS
Z	1000 F1	80 - 82	539 HF*	512 HF
Z	1000 GL	80 - 82	510 HF*	512 HF
Z	1000 H1	80 - 83	510 HF*	512 HF
Z	1000 H2	20 - 23	900 HS*	657 LS
Z	1000 H2 SE	21 - 24	841 HS*	657 LS
Z	1000 J	79 - 83	539 HF*	540 HF
Z	1000 K, M, CSR	81 - 84	539 HF*	540 HF
Z	1000 LTD	77 - 79	510 HF*	514 HF
Z	1000 LTD	81 - 84	539 HF*	540 HF

**RECOMMENDED**1xx - 2xx = Scooter Pads  
5xx - 9xx = Street, Off Road & Racing Pads  
20xx = Brake Shoes**KAWASAKI**

Z	1000 MKII	79 - 80	539 HF*	512 HF
Z	1000 Police	82 - 84	539 HF*	540 HF
Z	1000 R	78 - 79	510 HF*	512 HF
Z	1000 R	17 - 18	841 HS*	687 LS
Z	1000 R Ninja	86 - 88	557 HF*	557 HF
Z	1000 RE1, R2	82 - 84	540 HF*	540 HF
Z	1000 SE	14 - 16	806 HS*	687 LS
Z	1000 ST	79 - 81	539 HF*	512 HF
Z	1000 SX	11 - 23	806 HS*	687 LS
ZL	1000	86 - 87	557 HF*	557 HF
ZX	1000 H2 Carbon Ninja	17 - 20	841 HS*	730 LS
ZX	1000 H2 Ninja	15 - 21	841 HS*	730 LS
ZX	1000 H2 SX	18 - 24	806 HS*	611 LS
ZX	1000 H2 SX SE	18 - 24	806 HS*	611 LS
ZX	1000 H2 SX SE+	19 - 21	841 HS*	611 LS
ZX	1000 H2R Ninja	15 - 24	841 HS*	730 LS
ZX-10	1000	88 - 90	597 HS*	597 LS
ZX-10R	1000 Ninja	04 - 07	788 HS*	687 LS
ZX-10R	1000 Ninja	08 - 10	806 HS*	687 LS
ZX-10R	1000 Ninja	11 - 15	806 HS*	834 LS
ZX-10R	1000 Ninja	16 - 24	841 HS*	834 LS
ZX-10R	1000 Ninja SE	18 - 22	841 HS*	834 LS
ZX-10RR	1000 Ninja	17 - 24	841 HS*	834 LS
	1100 Zephyr Left	97 - 02	705 HS	597 LS
	1100 Zephyr Right	97 - 02	704 HS	
GPZ	1100	81 - 82	539 HF*	540 HF
GPZ	1100	83 - 86	557 HF*	557 HF
GPZ	1100 (ZX 1100) Left	95 - 99	705 HS	687 LS
GPZ	1100 (ZX 1100) Right	95 - 99	704 HS	
GPZ	1100 ABS, Horizont Left	97 - 99	705 HS	687 LS
GPZ	1100 ABS, Horizont Right	97 - 99	704 HS	
Z	1100 GP	81 - 81	539 HF	540 HF
Z	1100 GP	82 - 82	540 HF	540 HF
Z	1100 GP	83 - 86	557 HF*	557 HF
Z	1100 L1, LTD	83 - 83	539 HF*	540 HF
Z	1100 LTD	85 - 87	557 HF*	557 HF
Z	1100 R, LTD	84 - 84	557 HF*	557 HF
Z	1100 Spectre	82 - 83	539 HF*	540 HF
Z	1100 ST	81 - 83	539 HF	512 HF
ZN	1100 LTD	84 - 84	557 HF*	557 HF
ZR	1100 Zephyr	92 - 95	631 HS*	597 LS
ZRX	1100	96 - 00	686 HS*	556 LS
ZX	1100	93 - 97	631 HS*	556 LS
ZX	1100 GP	83 - 83	557 HF*	557 HF
ZZR	1100	90 - 93	631 HS*	597 LS
ZZR	1100	94 - 01	631 HS*	556 LS
ZG	1200 Voyager XII	86 - 93	557 HS*	557 LS
ZRX	1200	01 - 04	686 HS*	556 LS
ZRX	1200 R	01 - 08	686 HS*	556 LS
ZRX	1200 S	01 - 07	686 HS*	556 LS
ZX-12R	1200 Ninja	00 - 03	686 HS*	556 LS
ZX-12R	1200 Ninja	04 - 06	788 HS*	556 LS
ZZR	1200	02 - 04	631 HS*	556 LS
Z	1300	79 - 81	530 HF*	512 HF
Z	1300	85 - 85	557 HF*	557 HF
Z	1300 , Sports	79 - 83	539 HF*	540 HF
Z	1300 DF1	84 - 84	530 HF*	512 HF
ZN	1300	83 - 84	557 HF*	557 HF
ZN	1300 Voy.	85 - 86	557 HF*	557 HF
GTR	1400	07 - 16	838 HS*	715 LS
GTR	1400 ABS	07 - 16	838 HS*	715 LS
ZZR	1400	06 - 19	838 HS*	715 LS
ZZR	1400 ABS	06 - 19	838 HS*	715 LS
ZZR	1400 Performance Sport	17 - 19	901 HS*	715 LS
ZZR	1400 SE	16 - 18	901 HS*	715 LS
VN	1500 Classic	97 - 04	705 HS	557 LS
VN	1500 Classic Fi	00 - 04	705 HS	886 LS
VN	1500 Classic Tourer Left	98 - 01	705 HS	557 LS
VN	1500 Classic Tourer Right	98 - 01	704 HS	
VN	1500 Classic Tourer Fi Left	00 - 04	705 HS	886 LS
VN	1500 Classic Tourer Fi Right	00 - 04	704 HS	
VN	1500 Drifter	99 - 02	705 HS	704 LS

\* = 2 sets required / 2 jeux pour l'Avant.

Full compound selection, see under "Brake pad 1:1 Drawings" / Sélection complète de composés, voir "1:1 Schémas Plaquettes de frein".



**RECOMMENDED**

1xx - 2xx = Scooter Pads  
 5xx - 9xx = Street, Off Road & Racing Pads  
 2xxx = Brake Shoes



KAWASAKI			
VN	1500 Mean Streak	02 - 03	686 HS 886 LS
VN	1500 Sumo	88 - 92	557 HF* 557 HF
VN	1500 Vulcan	87 - 92	557 HS 557 LS
VN	1500 Vulcan, SE	87 - 92	557 HS 557 LS
VN	1600 Classic Left	03 - 08	705 HS 886 LS
VN	1600 Classic Right	03 - 08	704 HS
VN	1600 Mean Streak	04 - 04	686 HS* 886 LS
VN	1600 Mean Streak	05 - 05	788 HS* 886 LS
VN	1700 Classic Left	09 - 14	705 HS 886 LS
VN	1700 Classic Right	09 - 14	704 HS
VN	1700 Classic Tourer Left	09 - 14	705 HS 886 LS
VN	1700 Classic Tourer Right	09 - 14	704 HS
VN	1700 Voyager	09 - 16	631 HS* 886 LS
VN	2000	04 - 10	631 HS* 886 LS

KEEWAY			
	50 Flash	07 - 12	101 HF 2028
	50 Flash Electric	10 - 12	141 HF 2028
	50 Focus	06 - 15	141 HF
	50 Hurricane	06 - 16	101 HF 2028
	50 Matrix	06 - 15	141 HF 2028
	50 Matrix Electric	10 - 15	141 HF
	50 Matrix Racing Sport	10 - 16	141 HF
F-NKD	50	10 - 11	141 HF 2028
RY8	50	07 - 09	141 HF 2028
RY8	50	10 - 16	141 HF 200 HF
TX	50 SM	10 - 12	173 HF
	90 Hurricane	06 - 09	101 HF
	100 Partner	06 - 10	119 HF
	110 Partner	06 - 07	119 HF
	125 Arn	06 - 08	123 CT
	125 Cityblade	17 - 19	232 HF 152 HF
	125 Enduro	07 - 08	774 HF 519 HF
	125 Focus	06 - 08	141 CT
	125 I K-Light	18 - 20	968 HF
	125 Logik	17 - 19	232 HF
	125 Matrix	06 - 08	141 CT
	125 Matrix Racing Sport	10 - 16	141 CT
	125 Silverblade	17 - 20	234 CT
	125 Speed	06 - 12	132 CT 119 CT
	125 Superlight	06 - 16	713 HF
	125 Superlight	17 - 19	961 HF
	125 X-Ray	07 - 08	774 HF 519 HF
RKS	125 EFI	18 - 20	968 HF
RKS	125 I Sport	17 - 20	968 HF
TX	125 SM	10 - 16	780 HF
	150 Arn	06 - 08	123 CT
	150 Focus	06 - 09	141 CT
	150 Matrix	06 - 08	141 CT
	150 Matrix Racing Sport	10 - 12	141 CT
	150 Speed	06 - 09	132 CT 119 CT
	150 Superlight	06 - 16	713 HF
	250 Land Cruiser	06 - 14	713 HF
	250 Supershadow	06 - 09	691 HF
M	502 N	23 - 23	674 HS* 675 LS

KOTIR			
RS	50	90 - 90	2028 2028

KOVE			
MX	250	24 - 24	694 RSI 777 RSI
MX	250 Enduro	24 - 24	694 SI 777 SI
MX	250 Off Road	23 - 23	694 RSI 777 RSI
MX	250 Supermoto	23 - 23	901 HS 777 HF
	322 321RR	23 - 23	900 HS 926 HF
	450 Rally	23 - 23	694 SI 777 SI
MX	450	24 - 24	694 RSI 777 RSI

KRAM-IT			
	50 Scrambler	90 - 90	692 HF
ER	125	89 - 93	608 SI 692 SI
	250 SMR	00 - 00	675 RSI



**RECOMMENDED**

1xx - 2xx = Scooter Pads  
 5xx - 9xx = Street, Off Road & Racing Pads  
 2xxx = Brake Shoes



KRAM-IT			
GS	250	97 - 00	671 SI 675 SI
MC	250	89 - 89	608 SI 692 SI
MX	250	97 - 00	671 SI 675 SI
SM	250	97 - 00	671 SI 675 SI
ER	300	89 - 89	608 SI 692 SI

KREIDLER			
	25 Florett XL	99 - 06	102 HF
	50 Florett	81 - 82	524 HF
	50 Florett	99 - 06	102 HF 2028
	125 Enduro	07 - 08	713 HF
	125 Florett D	07 - 08	638 HF
	125 Florett RMC-F	07 - 08	638 HF
	125 Mustang	83 - 87	560 HF 519 HF
	125 Supermoto	07 - 08	713 HF
	200 Enduro	07 - 08	713 HF

KTM			
	Freeride Electric	12 - 14	885 RSI 872 RSI
E-SM	Freeride	15 - 16	885 RSI 872 RSI
E-SX	Freeride	15 - 16	885 RSI 872 RSI
E-XC	Freeride	15 - 23	885 RSI 872 RSI
SX-E	5	19 - 24	794 RSI 794 RSI
	40 Comet	91 - 95	2120 2120
	50 Comet PL, TS, RLW, RS, RS4L	86 - 91	138 HF
GO	50	94 - 97	109 HF 2012
GP	50 DXL, RS1	76 - 79	138 HF
GXE	50	87 - 88	519 HF
GXE	50	89 - 92	131 HF*
GXR	50	89 - 91	131 HF*
MX	50	87 - 90	519 SI
MX	50	91 - 91	131 HF
RSV	50	86 - 89	519 SI
SM	50 Supermoto	06 - 06	794 RSI 794 RSI
SX	50	09 - 24	794 RSI 794 RSI
SX	50 Adventure	98 - 03	2074 2074
SX	50 Mini	09 - 24	794 RSI 794 RSI
SX	50 Pro Junior LC	02 - 05	794 RSI 2074
SX	50 Pro Senior LC	02 - 03	794 RSI 2074
SX	50 Pro Senior LC	04 - 09	794 RSI 794 RSI
SX	50 Senior Adventure	04 - 07	794 RSI 2074
X-1	50	98 - 91	2028
SX	60	99 - 99	559 RSI
SX	65	00 - 01	559 RSI 574 RSI
SX	65	02 - 03	783 RSI 574 RSI
SX	65	04 - 08	783 RSI 794 RSI
SX	65	09 - 22	783 RSI 783 RSI
SX	65	23 - 24	791 RSI 791 RSI
	80 RSL, L, RS, RL	80 - 85	519 HF 519 HF
MX	80	86 - 90	583 HF 2122
MX	80	91 - 92	583 HF
PL	80	85 - 88	519 HF 519 HF
RLW	80	80 - 81	519 SI 519 SI
MX	85	90 - 90	519 SI
SX	85 (17/14)	04 - 10	783 RSI 783 RSI
SX	85 (17/14)	11 - 11	783 RSI 872 RSI
SX	85 (17/14)	12 - 20	885 RSI 872 RSI
SX	85 (17/14)	21 - 24	671 RSI 791 RSI
SX	85 (19/16)	13 - 20	885 RSI 872 RSI
SX	85 (19/16)	21 - 24	671 RSI 791 RSI
	125	83 - 83	2120 2120
	125 Duke	11 - 19	877 HS 675 LS
	125 Sting	99 - 99	566 HF 675 HF
	125 SuperMoto	00 - 03	671 HF 675 HF
EGS	125	99 - 99	671 HS 675 LS
EXC	125	90 - 90	621 HF 621 HF
EXC	125 Enduro	99 - 03	671 SI 675 SI
EXC	125 Enduro	04 - 15	671 SI 791 SI
EXE	125	00 - 00	671 HF 675 HF
GS	125	83 - 83	2122 2120
GS	125	84 - 85	2122 2122
GS	125	88 - 88	621 HF 621 HF

\* = 2 sets required / 2 jeux pour l'Avant.

Full compound selection, see under "Brake pad 1:1 Drawings" / Sélection complète de composés, voir "1:1 Schémas Plaquettes de frein".



**RECOMMENDED**1xx - 2xx = Scooter Pads  
5xx - 9xx = Street, Off Road & Racing Pads  
2xxx = Brake Shoes

KTM					
GS	125	89 - 90	546 SI	586 SI	
GS	125	92 - 97	671 SI	586 SI	
LC	125	85 - 85	519 SI		
LC	125	86 - 86	519 SI	519 SI	
LC2	125	99 - 99	671 HF	675 HF	
LL	125	83 - 83	2122	2120	
MX	125	84 - 84	2122	2122	
MX	125	85 - 85	519 SI	2122	
MX	125	86 - 86	519 SI	519 SI	
MX	125	88 - 88	621 HF	621 HF	
MX	125	89 - 90	546 SI	692 SI	
MX	125	92 - 93	671 SI	692 SI	
RC	125	14 - 22	877 HS	675 LS	
SX	125	96 - 03	671 RSI	675 RSI	
SX	125	04 - 24	671 RSI	791 RSI	
SXS	125	01 - 02	671 RSI	675 RSI	
XC	125	85 - 85	519 SI	2122	
XC	125	86 - 89	519 SI	519 SI	
SX	144	07 - 08	671 RSI	791 RSI	
EXC	150 TPI	20 - 23	671 SI	791 SI	
SX	150	09 - 23	671 RSI	791 RSI	
XC-W	150	17 - 23	671 SI	791 SI	
	175	79 - 82	2120	2121	
	200 Duke	12 - 17	877 HS	675 LS	
EXC	200	99 - 00	671 SI	675 SI	
EXC	200 Enduro	99 - 03	671 SI	675 SI	
EXC	200 Enduro	04 - 16	671 SI	791 SI	
RC	200	14 - 22	877 HS	675 LS	
SX	200	03 - 04	671 RSI	791 RSI	
	250 Baja	86 - 89	519 SI	2122	
	250 Country,Baja	85 - 85	519 SI	2122	
	250 Cross	80 - 81	2120	2120	
	250 Cross	82 - 82	2121	2121	
	250 Cross	83 - 83	2118	2121	
	250 Duke	14 - 15	877 HS	675 LS	
	250 Freeride R	14 - 19	885 RSI	872 RSI	
	250 GS,EXC,Enduro Models	91 - 91	621 HF	586 SI	
EXC	250	90 - 90	621 HF	621 HF	
EXC	250 Enduro	99 - 03	671 SI	675 SI	
EXC	250 Enduro	04 - 08	671 SI	791 SI	
EXC	250 Enduro 4T	99 - 03	671 SI	675 SI	
EXC	250 Enduro 4T	04 - 06	671 SI	791 SI	
EXC	250 TPI	18 - 23	671 SI	791 SI	
EXC-F	250	07 - 23	671 SI	791 SI	
GS	250	83 - 85	2122	2122	
GS	250	88 - 88	621 HF	621 HF	
GS	250	89 - 90	546 SI	586 SI	
LC	250	85 - 85	519 SI		
LC	250	86 - 86	519 SI	519 SI	
MC	250	83 - 84	519 SI	519 SI	
MX	250	84 - 84	2122	2122	
MX	250	85 - 85	519 SI	2122	
MX	250	88 - 88	621 HF	621 HF	
MX	250	89 - 90	546 SI	692 SI	
MX	250	92 - 93	671 SI	692 SI	
MX	250 VC, Enduro	87 - 90	601 HF	601 HF	
RC	250	14 - 15	877 HS	675 LS	
RC4R	250	20 - 20	706 RST	675 RQ	
SX	250	96 - 02	671 RSI	675 RSI	
SX	250	03 - 24	671 RSI	791 RSI	
SX-F	250	06 - 24	671 RSI	791 RSI	
XC	250	85 - 85	519 SI		
XC	250	86 - 89	519 SI	519 SI	
XC	250	06 - 14	671 RSI	791 RSI	
EXC	300	90 - 90	621 HF	621 HF	
EXC	300	93 - 96	671 SI	586 SI	
EXC	300 Enduro	99 - 03	671 SI	675 SI	
EXC	300 Enduro	04 - 08	671 SI	791 SI	
EXC	300 TPI	18 - 23	671 SI	791 SI	
GS	300	85 - 85	2122	2122	
MX	300	85 - 89		2122	
MX	300	90 - 90	546 SI	586 SI	

**RECOMMENDED**1xx - 2xx = Scooter Pads  
5xx - 9xx = Street, Off Road & Racing Pads  
2xxx = Brake Shoes

KTM					
MX	300	92 - 92	671 SI	586 SI	
SX	300	23 - 24	671 RSI	791 RSI	
XC	300	85 - 85	519 SI	2122	
XC	300	86 - 90	519 SI	519 SI	
XC	300	06 - 14	671 RSI	791 RSI	
XC	300 (Drum vers.)	85 - 85	2122	2122	
	350 Country Cross	85 - 85	519 SI	2122	
	350 Freeride	12 - 17	885 RSI	872 RSI	
	350 GS	83 - 85	519 SI	2121	
	350 GS (Drum vers.)	83 - 85	2122	2122	
EXC	350	87 - 87	601 HF	601 HF	
EXC	350	88 - 90	621 HF	621 HF	
EXC-F	350	11 - 23	671 SI	791 SI	
GS	350	87 - 87	601 HF	601 HF	
GS	350	88 - 92	621 HF	621 HF	
GS4	350 500 K4	82 - 83	519 SI		
K4	350 500 K4	82 - 83	519 SI		
LC4	350	92 - 95	546 SI	586 SI	
MX	350	87 - 87	601 HF	601 HF	
MX	350	88 - 88	621 HF	621 HF	
SX-F	350	11 - 24	671 RSI	791 RSI	
XC	350 , MC	81 - 83	519 SI		
MX	360	96 - 97	671 SI	675 SI	
SX	360	96 - 97	671 RSI	675 RSI	
XC	360	96 - 97	671 SI	675 SI	
EXC	380 Enduro	99 - 99	671 SI	675 SI	
MX	380	98 - 98	671 SI	675 SI	
SX	380	98 - 02	671 RSI	675 RSI	
XC	380	98 - 03	671 SI	675 SI	
	390 Adventure	20 - 23	877 HS	675 LS	
	390 Adventure SW	23 - 23	877 HS	675 LS	
	390 Duke	13 - 23	877 HS	675 LS	
	390 GS	83 - 83	519 SI	2121	
	390 GS (Drum vers.)	83 - 83	2122	2122	
RC	390	14 - 23	877 HS	675 LS	
XC	390 , MC	81 - 83	519 SI		
	400 Enduro	87 - 90	601 HF	601 HF	
EXC	400 Racing	00 - 03	671 SI	675 SI	
EXC	400 Racing	04 - 07	671 SI	791 SI	
LC4	400	93 - 02	671 SI	586 SI	
LC4-E	400 Enduro	99 - 02	671 SI	675 SI	
SC	400	99 - 00	671 SI	675 SI	
SX	400	00 - 02	671 RSI	675 RSI	
SXC	400 Ttainen Replica	99 - 00	671 SI	675 SI	
GS	420	84 - 87	2122	2122	
XC	420 , MC	81 - 83	519 SI		
	450 Rally	11 - 17	674 SI	675 SI	
	450 Rally	19 - 22	674 SI	791 SI	
EXC-F	450	04 - 23	671 SI	791 SI	
SX	450 ATV	08 - 10	866 RSI*	867 RSI	
SX	450 SM Factory Replica	04 - 07	566 RSI	791 RSI	
SX	450 SMR	04 - 06	842 RSI	791 RSI	
SX	450 SMR	07 - 12	843 RSI	791 RSI	
SX	450 SMR	13 - 15	841 RST	791 RSI	
SX	450 SMR	21 - 22	841 RST	791 RSI	
SX-F	450	03 - 24	671 RSI	791 RSI	
XC	450 ATV	08 - 10	866 SI*	867 SI	
XC-F	450	06 - 23	671 RSI	791 RSI	
MC	495 Leleu	82 - 83	519 SI	2121	
MX	495	84 - 84	2122	2122	
MX	495 Leleu	82 - 83	519 SI	2121	
	500 Cross	82 - 82	2118	2121	
EXC-F	500	12 - 24	671 SI	791 SI	
GS	500 500 K4 Enduro	83 - 83	519 SI	2121	
LC	500	85 - 85	519 SI	2122	
LC	500	86 - 89	519 SI	519 SI	
MX	500	83 - 84	2122	2122	
MX	500	85 - 85	519 SI	2122	
MX	500	86 - 86	519 SI	519 SI	
MX	500	87 - 87	601 HF	601 HF	
MX	500	88 - 88	621 HF	621 HF	
MX	500	89 - 91	546 SI	692 SI	

\* = 2 sets required / 2 jeux pour l'Avant.

Full compound selection, see under "Brake pad 1:1 Drawings" / Sélection complète de composés, voir "1:1 Schémas Plaquettes de frein".



**RECOMMENDED**

1xx - 2xx = Scooter Pads  
5xx - 9xx = Street, Off Road & Racing Pads  
2xxx = Brake Shoes



KTM					
MX	500	92 - 93	671 SI	692 SI	
XC	500 , MC	81 - 83	519 SI		
SX	505 ATV	08 - 12	866 RSI*	867 RSI	
SX	505	07 - 09	671 RSI	791 RSI	
SX-F	505	07 - 08	671 RSI	791 RSI	
XC	505 ATV	08 - 12	866 SI*	867 SI	
XC-F	505	08 - 09	671 RSI	791 RSI	
EXC	520 Racing	00 - 02	671 SI	675 SI	
SX-F	520	00 - 02	671 RSI	675 RSI	
EXC	525 Racing	03 - 03	671 SI	675 SI	
EXC	525 Racing	04 - 06	671 SI	791 SI	
SX	525 SMR	04 - 07	842 RSI	791 RSI	
SX-F	525	03 - 03	671 RSI	675 RSI	
SX-F	525	04 - 06	671 RSI	791 RSI	
EXC	530 Racing	08 - 11	671 SI	791 SI	
SXC	540	98 - 98	671 SI	675 SI	
SXC	540 Tiainen Replica	99 - 00	671 SI	675 SI	
SXS	540	01 - 02	671 RSI	675 RSI	
LC4	550	87 - 89	601 HF	601 HF	
MX	550	87 - 90	601 HF	601 HF	
SX	560 SMR	06 - 07	843 RSI	791 RSI	
	600 Duke	93 - 94	566 HF		
4T	600 Enduro	84 - 86	519 SI		
EXC	600	87 - 87	601 HF	601 HF	
EXC	600	88 - 88	621 HF	621 HF	
GS	600	84 - 84	2122	2122	
GS	600	85 - 85	519 SI	2122	
LC4	600	88 - 91	601 HF	601 HF	
LC4	600 Enduro	88 - 91	601 HF	601 HF	
LC4	600 Six Days	92 - 92	671 SI	586 SI	
MC	600	88 - 88	601 HF	601 HF	
MX	600	87 - 87	601 HF	601 HF	
MX	600	88 - 89	621 HF	621 HF	
XC	600 Cross	85 - 85	519 SI		
XCE	600 Cross	85 - 85	519 SI		
	620 Duke	96 - 98	566 HF	519 HF	
LC4	620 Competition	99 - 02	671 SI	675 SI	
LC4	620 Competition SuperMoto	00 - 01	671 HF	675 HF	
LC4	620 RXC	95 - 95	671 SI	675 SI	
LC4	620 Supercompetition	01 - 01	671 HF	675 HF	
SC	620	99 - 00	671 SI	675 SI	
SX	620	95 - 99	671 RSI	675 RSI	
LC4	625 SC Supermoto	02 - 04	671 HF	675 HF	
SMC	625	05 - 06	706 HF	675 HF	
SXC	625	03 - 04	671 HF	675 HF	
	640 Duke	99 - 02	566 HF	519 HF	
	640 Duke	03 - 06	706 HF	675 HF	
LC4	640 Adventure	99 - 04	671 HF	675 HF	
LC4	640 Adventure	05 - 07	674 HF	675 HF	
LC4	640 Supermoto	03 - 03	566 HF	675 HF	
LC4	640 Supermoto	04 - 04	706 HF	675 HF	
LC4-E	640 Enduro	99 - 04	671 HF	675 HF	
LC4-E	640 Supermoto	99 - 02	671 HF	675 HF	
LC4	660 Rally	01 - 03	671 HF	675 HF	
LC4	660 SM Factory Replica	02 - 02	566 RSI	675 RSI	
SMC	660 Supermoto	03 - 03	566 HF	675 HF	
SMC	660 Supermoto	04 - 07	706 HF	675 HF	
	690 Duke	08 - 11	762 HS	675 LS	
	690 Duke ABS	12 - 19	706 HS	675 LS	
	690 Duke R	10 - 11	762 HS	675 LS	
	690 Duke R	14 - 17	841 HS	675 LS	
	690 Enduro	08 - 14	674 HS	675 LS	
	690 Enduro R	09 - 23	674 HS	675 LS	
	690 SM	07 - 11	762 HS	675 LS	
	690 SMC	08 - 10	762 HS	675 LS	
	690 SMC R	14 - 20	762 HS	675 LS	
	690 SMC R	21 - 24	900 HS	675 LS	
	690 Supermoto	07 - 07	706 HS	675 LS	
	690 Supermoto R	08 - 09	762 HS	675 LS	
	790 Adventure	19 - 24	706 HS*	671 LS	
	790 Adventure R	19 - 20	706 HS*	671 LS	
	790 Adventure R Rally	20 - 20	706 HS*	671 LS	



**RECOMMENDED**

1xx - 2xx = Scooter Pads  
5xx - 9xx = Street, Off Road & Racing Pads  
2xxx = Brake Shoes



KTM					
	790 Duke	18 - 20	706 HS*	675 LS	
	890 Adventure R	21 - 24	706 HS*	671 LS	
	890 Adventure R Rally	24 - 24	706 HS*	671 LS	
	890 Duke R	20 - 20	901 HS*	675 LS	
	890 SMT	24 - 24	706 HS*	671 LS	
RC8	890 C	22 - 22	841 RST*	730 LS	
	950 R Superenduro	06 - 08	674 HS	671 LS	
	950 SM	05 - 07	762 HS*	671 LS	
	950 SM R	07 - 09	762 HS*	671 LS	
LC8	950 Adventure	02 - 07	674 HS*	671 LS	
	990 Adventure	06 - 11	674 HS	671 LS	
	990 Adventure R	10 - 12	674 HS*	671 LS	
	990 Adventure S, ABS	06 - 11	674 HS	671 LS	
	990 Super Duke	04 - 13	762 HS*	675 LS	
	990 Super Duke R	09 - 13	762 HS*	675 LS	
	990 Supermoto	07 - 11	762 HS*	671 LS	
	990 Supermoto R	10 - 10	841 HS*	671 LS	
	990 Supermoto T	09 - 13	762 HS*	671 LS	
	1050 Adventure	15 - 16	706 HS*	671 LS	
	1090 Adventure R	17 - 19	706 HS*	671 LS	
	1090 Super Adventure	17 - 19	706 HS*	671 LS	
	1090 Super Adventure R	17 - 20	706 HS*	671 LS	
	1190 Adventure	13 - 16	706 HS*	671 LS	
RC8	1190	08 - 11	841 HS*	730 LS	
RC8	1190 R	09 - 15	841 HS*	730 LS	
RC8	1190 R Track	11 - 15	841 HS*	730 LS	
	1290 Super Adventure	15 - 16	706 HS*	671 LS	
	1290 Super Adventure R	17 - 20	706 HS*	671 LS	
	1290 Super Adventure S	17 - 23	706 HS*	671 LS	
	1290 Super Adventure T	17 - 19	706 HS*	671 LS	
	1290 Super Duke GT	16 - 20	901 HS*	730 LS	
	1290 Super Duke R	14 - 22	841 HS*	730 LS	
	1290 Super Duke R EVO	22 - 22	841 HS*	730 LS	
	1290 Superduke R Black	20 - 20	841 HS*	730 LS	
KYMCO					
	50 Agility	05 - 08	163 HF	2012	
	50 Agility (4T) R10	06 - 14	163 HF	2012	
	50 Agility (4T) R12	06 - 15	163 HF	2012	
	50 Agility (4T) R16	06 - 15	154 HF	2203	
	50 Agility Basic	07 - 07	2012	2012	
	50 B&W	04 - 06	119 HF		
	50 Calypso	97 - 99	141 HF	2012	
	50 Cobra Cross	99 - 00	144 HF	2012	
	50 Cobra Cross	01 - 06	121 HF	2012	
	50 Cobra Exclusive	01 - 04	121 HF	2012	
	50 Cobra Racer	99 - 00	144 HF	2012	
	50 Cobra Racer	01 - 04	121 HF	2012	
	50 Dink, Dink Sport, B&W	99 - 02	119 HF	2012	
	50 Easy	01 - 01	121 HF	2012	
	50 Filly	99 - 03	2012	2012	
	50 Filly LX	01 - 01	121 HF	2012	
	50 Filly LX	02 - 06	163 HF		
	50 Heroism	95 - 96	121 HF	2012	
	50 Heroism	97 - 99	141 HF	2012	
	50 K-Pipe	12 - 13	119 HF		
	50 Manboy	95 - 00	110 HF	2012	
	50 MXer	03 - 07	2012*	749 HF	
	50 MXU	05 - 10	2012*	749 HF	
	50 New Dink	08 - 13	119 HF		
	50 New G-Dink	12 - 13	183 HF		
	50 New Sento	11 - 15	163 HF		
	50 Nexxon	08 - 12	200 HF	200 HF	
	50 People	99 - 06	154 HF	2203	
	50 Refined	94 - 98	2012	2012	
	50 Scout	95 - 00	121 HF	2012	
	50 Sento	08 - 10	163 HF	2012	
	50 Spacer	99 - 06	119 HF	2012	
	50 Super-8	08 - 16	154 HF	2203	
	50 Super-9	00 - 01	144 HF		
	50 Super-9 A/C	02 - 07	119 HF		
	50 Super-9 L/C	02 - 07	119 HF	154 HF	

\* = 2 sets required / 2 jeux pour l'Avant.

Full compound selection, see under "Brake pad 1:1 Drawings" / Sélection complète de composés, voir "1:1 Schémas Plaquettes de frein".

**RECOMMENDED**1xx - 2xx = Scooter Pads  
5xx - 9xx = Street, Off Road & Racing Pads  
2xxx = Brake Shoes

KYMCO					
	50 Topboy on/off road	96 - 05	121 HF	2012	
	50 Topboy Racer/Cross	01 - 05	121 HF	2012	
	50 Vitality	04 - 09	163 HF		
	50 Yager	01 - 07	119 HF	2012	
	50 Yup	01 - 01	121 HF	2012	
	50 Yup SP/AL	02 - 09	163 HF		
	50 Zap (Disc Brake version)	95 - 00	110 HF		
	50 ZX 12	06 - 06	144 HF		
CX	50	94 - 97	2012	2057	
CX	50 Curio Super	94 - 97	121 HF	2057	
DD	50 Sniper	94 - 96	121 HF	129 HF	
DJ	50	99 - 02	2012	2057	
DJ	50 Refined	99 - 02	2012	2057	
DJW	50	94 - 97	2012	2057	
DJX	50	91 - 92	2012	2057	
DJY	50	93 - 06	2012	2057	
K12	50	95 - 00	121 HF	2012	
KB	50	95 - 00	121 HF	2012	
RS	50 Agility Naked	10 - 15	163 HF		
ZX	50 Fever	96 - 01	121 HF	2057	
ZX	50 Super Fever	02 - 06	144 HF		
	80 Filly	99 - 02	2012	2012	
	90 Manboy	96 - 01	144 HF	2012	
SP	90 Yup	95 - 99	110 HF		
	100 Cobra Racer	99 - 03	119 HF	2012	
	100 Spike	02 - 06	103 HF		
	100 Topboy on/off road	99 - 00	121 HF	2012	
KB	100	99 - 00	121 HF	2012	
	110 Spike	03 - 06	103 HF		
	125 Agility	06 - 11	163 CT	2012	
	125 Agility 16+	14 - 16	154 CT	119 CT	
	125 Agility City	11 - 17	163 CT	113 CT	
	125 B&W, Dink Sport	99 - 06	119 CT	119 CT	
	125 Calypso	99 - 99	141 CT	2012	
	125 Cruiser	99 - 99	119 CT		
	125 Dink	96 - 09	119 CT	119 CT	
	125 Dink X	22 - 22	159 CT	204 CT	
	125 Dntown i	10 - 14	183 CT	204 CT	
	125 Grand Dink	02 - 07	119 CT	119 CT	
	125 Heroism	95 - 97	141 CT	2012	
	125 Hipster	01 - 06	688 HF		
	125 Jetix	08 - 15	103 CT		
	125 K-Pipe	13 - 15	688 HF		
	125 K-XCTi	13 - 14	183 CT	195 MS	
	125 Like	11 - 16	163 CT		
	125 Movie	99 - 08	119 CT	2203	
	125 Movie XL	01 - 09	119 CT		
	125 MXer	03 - 07	2012*	749 HF	
	125 New Dink	08 - 10	119 CT	119 CT	
	125 New Dntown	16 - 17	159 CT	204 CT	
	125 New G-Dink	12 - 14	183 CT	195 CT	
	125 Nexxon	08 - 12	200 CT	200 CT	
	125 People	01 - 09	154 CT	2203	
	125 People GTi	12 - 15	159 CT	204 CT	
	125 People One i	14 - 16	154 CT		
	125 Pulsar	01 - 13	688 HF		
	125 Quannon	08 - 12	119 CT	119 CT	
	125 Spacer	99 - 03	119 CT	119 CT	
	125 Spike	02 - 06	103 CT		
	125 Stryker on/off	99 - 06	163 CT		
	125 Super Dink	10 - 15	183 CT	204 CT	
	125 Super-8	08 - 15	154 CT		
	125 Super-9	00 - 01	144 CT	154 CT	
	125 Techno GT	06 - 10	119 CT		
	125 Vivio	01 - 03	163 CT		
	125 X-Town	16 - 17	159 MS	204 MS	
	125 X-Town CT	20 - 20	159 CT	204 CT	
	125 Yager	01 - 07	119 CT	119 CT	
	125 Yager GT	09 - 09	119 CT		
	125 Zing	96 - 14	688 HF		
B	125 Freeway	93 - 95	106 CT	2012	
CK	125	04 - 13	551 HF		

**RECOMMENDED**1xx - 2xx = Scooter Pads  
5xx - 9xx = Street, Off Road & Racing Pads  
2xxx = Brake Shoes

KYMCO					
CK-1	125	14 - 16	688 HF		
D2	125 Freeway	95 - 92	2012	2012	
DT	125 X360	22 - 23	159 CT	204 CT	
S	125 People	05 - 08	154 CT	195 CT	
	150 B&W	01 - 05	119 CT	119 CT	
	150 Dink	99 - 04	119 CT	119 CT	
	150 Freeway	95 - 00	121 HF	2012	
	150 Grand Dink	02 - 11	119 CT	119 CT	
	150 Heroism	95 - 07	141 CT	129 CT	
	150 Hipster	01 - 06	688 HF		
	150 Movie XL	01 - 09	119 CT		
	150 MXer	03 - 13	2012*	749 HF	
	150 MXU	05 - 17	2012*	749 HF	
	150 People	01 - 06	154 CT	2203	
	150 Quannon	10 - 14	119 CT	119 CT	
	150 Spacer	99 - 04	119 CT	119 CT	
	150 Straight	08 - 11	200 CT	200 CT	
	150 Stryker Off	01 - 06	163 CT		
	150 Vivio	01 - 02	163 CT		
	150 Yager	01 - 05	119 CT	119 CT	
	150 Zing	99 - 13	119 CT		
DX	150 Custom	93 - 96	551 HF		
NSR	150	93 - 93	551 HF		
	200 Agility 16+	14 - 17	154 CT	119 CT	
	200 Agility R16	11 - 15	154 CT	119 CT	
	200 Dink	04 - 12	119 CT	119 CT	
	200 Dntown i	10 - 15	183 CT	204 CT	
	200 i New Dink	08 - 12	119 CT	119 CT	
	200 Like i	10 - 16	119 CT	119 CT	
	200 People GTi	12 - 15	159 CT	204 CT	
	200 Yager	04 - 13	119 CT	119 CT	
S	200 People	05 - 07	154 CT	195 CT	
	250 B&W, Dink Sport	01 - 06	119 MS	119 MS	
	250 Grand Dink	01 - 10	171 MS	172 MS	
	250 MXU	06 - 14	810 SI*	775 SI	
	250 People	03 - 12	119 MS		
	250 Super-9	00 - 05	144 CT	154 CT	
	250 Urban Quad	06 - 06	810 SI*	775 SI	
	250 Venox	01 - 14	627 HF	627 HF	
	250 Xciting	04 - 05	183 MS	183 MS	
	250 Xciting	06 - 09	183 MS	195 MS	
	250 Yup	03 - 05	119 MS	119 MS	
KXR	250	04 - 14	810 SI*	775 SI	
S	250 People Left	06 - 08	197 MS	195 MS	
S	250 People Right	06 - 08	134 MS		
	300 Agility+	20 - 22	204 MS	204 MS	
	300 Dntown i	10 - 15	183 MS	204 MS	
	300 K-XCTi	12 - 15	159 MS	195 MS	
	300 Maxxer	06 - 13	810 SI*	775 SI	
	300 Maxxer Supermoto	15 - 15	810 SI*	775 SI	
	300 MXU	06 - 17	810 SI*	810 SI*	
	300 New G-Dink	12 - 16	183 MS	195 MS	
	300 People GTi	10 - 11	183 MS		
	300 People GTi	12 - 15	159 MS	204 MS	
	300 People S	20 - 20	159 MS	204 MS	
	300 People Si Left	08 - 10	163 CT	195 CT	
	300 People Si Right	08 - 10	119 CT		
	300 Xciting Ri	08 - 14	183 MS*	195 MS	
	300 X-Town	16 - 20	159 MS	195 MS	
	300 X-Town CT	20 - 20	159 MS	204 MS	
	350 New Dntown	16 - 17	159 MS	204 MS	
DT	350 X360	23 - 23	159 MS	204 MS	
	400 Maxxer	08 - 10	822 ATS*	822 ATS	
	400 Maxxer (Parking Brake)	08 - 10		921 HF	
	400 MXU	08 - 11	822 ATS*	822 ATS	
	400 MXU (Parking Brake)	08 - 11		921 HF	
	400 Xciting i	12 - 14	214 MS*	212 MS	
S	400 Xciting i TCS	22 - 23	214 MS	212 CT	
	450 i Maxxer	10 - 14	822 ATS*	822 ATS	
	450 i Maxxer (Parking Brake)	10 - 14		921 HF	
	450 i MXU	11 - 14	822 ATS*	822 ATS	
	450 i MXU (Parking Brake)	11 - 14		921 HF	

\* = 2 sets required / 2 jeux pour l'Avant.

Full compound selection, see under "Brake pad 1:1 Drawings" / Sélection complète de composés, voir "1:1 Schémas Plaquettes de frein".





**RECOMMENDED**

1xx - 2xx = Scooter Pads  
5xx - 9xx = Street, Off Road & Racing Pads  
2xxx = Brake Shoes



KYMCO				
500 MXU	06 - 08	810 SI*	810 SI*	
500 MXU	09 - 14	945 SI*		
500 MXU DX	11 - 13	945 SI*		
500 UXV 4x4	08 - 14	810 SI*	810 SI	
500 Xciting	04 - 15	183 MS*	212 MS	
500 Xciting i Evo ABS	11 - 13	183 MS*	212 MS	
500 Xciting R ABS	09 - 13	183 MS*	212 MS	
550 MXU	12 - 20	945 SI*	810 SI	
AK 550	17 - 23	239 MS*	238 HF	
AK 550 ST	22 - 23	239 MS*	238 HF	
700 MXU	13 - 20	945 SI*	810 SI	
700 MyRoad, ABS	09 - 15	183 MS*	212 MS	
UXV 700	14 - 16	945 SI*		
LAMBRETTA				
50 Pato	08 - 09	211 HF		
V 50 Special	21 - 23	140 HF		
V 50 Special Flex	21 - 23	140 HF		
V 125 Special	21 - 23	140 CT	202 CT	
V 125 Special Flex	21 - 23	140 CT	202 CT	
V 200 Special	21 - 23	140 CT	202 CT	
V 200 Special Flex	21 - 23	140 CT	202 CT	
LAVERDA				
50 Gaucho	92 - 92	519 HF	519 HF	
OR 50 Atlas	86 - 92	519 HF	519 HF	
125 Custom	86 - 99	519 HF		
125 Formula	86 - 89	574 HF		
125 Phoenix	01 - 04	178 CT	154 CT	
CU 125 Ride	86 - 99	519 HF		
GS 125 Lesmo	86 - 94	574 HF	574 HF	
HP 125 Quasar	04 - 04		758 ATS	
LB 125 Strada, Sport	85 - 85	574 HF		
LB 125 Uno	85 - 89	519 HF		
150 Phoenix	01 - 04	178 CT	154 CT	
HP 180 Quasar	04 - 04		758 ATS	
200 Phoenix	01 - 04	178 CT	154 CT	
GS 350 Lesmo	86 - 89	519 HF*	519 HF	
PF 350 Alpino	77 - 83	519 HF*	519 HF	
RS 350 Alpino	77 - 83	519 HF*	519 HF	
400 Quasar 4x4	04 - 04	758 ATS*	758 ATS	
500 Alpino, S	77 - 83	519 HF*	519 HF	
500 Quasar 4x4	04 - 04	758 ATS*	758 ATS	
500 Quasar 4x4 C	04 - 04	758 ATS*	758 ATS	
SFC 500	81 - 83	506 HF*	506 HF	
OR 600 Atlas	86 - 90	594 HF	519 HF	
SFC 600	86 - 89	506 HF*	506 HF	
650	92 - 92	566 HF*	519 HF	
650 V-Six	93 - 93	506 HS*	506 LS	
668	96 - 97	566 HF	519 HF	
668 Ghost, Diamante	97 - 97	566 HF*	519 HF	
700 El Cid	90 - 90	546 HF	586 HF	
750 Cup	98 - 01	566 HF*	519 HF	
750 Diamante	97 - 01	566 HF*	519 HF	
750 Ghost Strike	97 - 01	566 HF*	519 HF	
750 S Formula	97 - 01	566 HF*	519 HF	
750 S, S Carenata	97 - 01	566 HF*	519 HF	
750 Sport	99 - 01	566 HF*	519 HF	
750 Strike/Black Strike	99 - 01	566 HF*	519 HF	
750 T8	98 - 01	566 HF*	519 HF	
SF2 750	74 - 78	506 HF*		
SF3 750	74 - 78	506 HF*		
SF3 750 RGS Corsa, Executive	77 - 79	506 HF*	506 HF	
TTS 800	99 - 99	566 HF*	730 HF	
1000 Jota	76 - 79	506 HF*	506 HF	
3C 1000 3CE, 3CL	74 - 75	506 HF*	506 HF	
JOTA 1000	95 - 95	566 HF	519 HF	
RGS 1000	83 - 83	506 HF*	506 HF	
RGS 1000 Jota	86 - 86	506 HF*	506 HF	
SFC 1000	85 - 86	506 HF*	506 HF	
SFC 1000	04 - 04	762 HS*	730 LS	
TGA 1000 Executive	84 - 84	506 HF*	506 HF	



**RECOMMENDED**

1xx - 2xx = Scooter Pads  
5xx - 9xx = Street, Off Road & Racing Pads  
2xxx = Brake Shoes



LAVERDA				
1200 Mirage	78 - 80	506 HF*	506 HF	
LEM				
50 CX2, CX3, RX2, RX3	03 - 06	794 RSI	794 RSI	
50 Flash	94 - 98	111 HF	2028	
50 Ghibli	90 - 95	2028	2028	
50 R2, R3, R3 XC	03 - 06	794 RSI	794 RSI	
RX 65	05 - 10	794 RSI	794 RSI	
RX 150	11 - 11		794 RSI	
LIFAN				
LF 125 Off Road	07 - 07	211 HF	213 HF	
LIVEWIRE				
ONE	19 - 24	900 H.HS*	730 LS	
S2 Del Mar	24 - 24	900 H.HS	993 H.LS	
S2 Del Mar LE	24 - 24	900 H.HS	993 H.LS	
LONCIN				
LX 110 4	02 - 02	688 HF		
LX 125	02 - 02	688 HF		
LX 150 6	02 - 02	691 HF		
MACAL				
50 Flash	99 - 99	123 HF		
AM5/6 50 Trophy	99 - 99	105 HF		
AM5/6 50 Trophy H20	99 - 99	105 HF		
MACBOR				
XC 50 510 Racing	04 - 04	803 RSI	559 RSI	
XC 50 512 Pro	04 - 04	803 RSI		
XC 50 512 Racing	04 - 04	803 RSI	559 RSI	
XC 50 512 T	04 - 04	803 RSI		
XC 50 515 R 6V	04 - 04	803 RSI	559 RSI	
MAICO				
all models	89 - 89	621 HF	621 HF	
all models	91 - 91	621 HF	586 SI	
50 Classic	99 - 99	2028	2028	
50 Cruiser	99 - 99	101 HF	2028	
50 Thunderbike I	99 - 99	101 HF	2028	
50 Thunderbike II	99 - 99	101 HF*	2028	
50 Traffijammer	99 - 99	2028	2028	
C-1 50 Hard Enduro	99 - 99	101 HF	2028	
R-1 50 Superbike	99 - 99	101 HF	2028	
X-1 50 SuperCross	99 - 99	101 HF	2028	
250 Motocross/Enduro	99 - 01	671 SI	675 SI	
GM 250 LC	85 - 85	519 SI		
GM 250 Star	86 - 86	581 HF	581 HF	
GP 250 all models	89 - 89	621 HF	621 HF	
GP 250 E	87 - 87	581 HF	581 HF	
GP 250 Motocross	87 - 87	581 HF	581 HF	
MD 250	83 - 85	519 SI	519 SI	
350	93 - 95	621 HF	621 HF	
GP 400 all models	89 - 89	621 HF	621 HF	
GP 400 E	87 - 88	581 HF	581 HF	
GP 400 Motocross	87 - 88	581 HF	581 HF	
500	93 - 94	621 HF	621 HF	
500 Motocross/Enduro	99 - 99	671 SI	675 SI	
500 Supermotard	99 - 99	671 HF	675 HF	
GM 500 LC	85 - 86	519 SI		
GM 500 Star	86 - 86	581 HF	581 HF	
GP 500 all models	89 - 89	621 HF	621 HF	
GP 500 E	87 - 87	581 HF	581 HF	
GP 500 Motocross	87 - 87	581 HF	581 HF	
GP 550	87 - 87	581 HF	581 HF	
MALAGUTI				
50 AJP Caliper incl. pin/spring	91 - 19	188 HF		
50 Centro	93 - 96	109 HF	2012	
50 Chopper 25, 40, 80, Fifty	83 - 83	532 HF		
50 Chopper HF, Watercooled	83 - 83	532 HF		

\* = 2 sets required / 2 jeux pour l'Avant.

Full compound selection, see under "Brake pad 1:1 Drawings" / Sélection complète de composés, voir "1:1 Schémas Plaquettes de frein".

**RECOMMENDED**1xx - 2xx = Scooter Pads  
5xx - 9xx = Street, Off Road & Racing Pads  
2xxx = Brake Shoes

MALAGUTI				
	50 Ciak	00 - 09	123 HF	2012
	50 Ciak Twin Disk	02 - 09	123 HF	123 HF
	50 Enduro	85 - 87	519 HF	
	50 Enduro Dune	87 - 88	132 HF	132 HF
	50 Evolution	91 - 91	574 HF	
	50 Fifty	04 - 04	168 HF	105 HF
	50 Fifty Evolution	91 - 91	559 HF	
	50 Fifty Full, CX, Top	85 - 85	595 HF	
	50 Fifty Mistral	90 - 95	595 HF	
	50 Yesterday	97 - 02	123 HF	2012
CH	50	86 - 86	595 HF	
CR-1	50 Crosser	95 - 96	132 HF	
EL	50 Crosser	97 - 00	123 HF	
ES	50 Dune	89 - 89	574 HF	574 HF
F-10	50	92 - 93	113 HF	2012
F-10	50 Jet-Line	94 - 98	123 HF	2012
F-10	50 Timemachine	03 - 09	123 HF	
F-10	50 WAP	02 - 09	123 HF	
F-12	50 Phantom	94 - 98	132 HF	2012
F-12	50 Phantom A.C.	99 - 03	123 HF	2012
F-12	50 Phantom Digit	02 - 10	123 HF	123 HF
F-12	50 Phantom L.C.	94 - 98	109 HF	2012
F-12	50 Phantom L.C. dd	99 - 09	123 HF	123 HF
F-12	50 Racing Life	03 - 09	123 HF	123 HF
F-12	50 Tyre Track	03 - 09	123 HF	123 HF
F-15	50 Fire Fox	96 - 08	132 HF	2012
F-15	50 Fire Fox L.C.	96 - 08	109 HF	2012
F-15	50 Mechatronic	03 - 08	123 HF	123 HF
MDX	50	86 - 87	574 HF	
MDX	50 Gold Enduro	87 - 87	607 HF	596 HF
MEX	50	86 - 87	541 HF	
MFX	50	86 - 87	541 HF	
MLX	50 Enduro	87 - 87	607 HF	596 HF
MRX	50	89 - 89	519 HF	
NKD	50	04 - 09	168 HF	105 HF
NKD	50 Dragon	06 - 09	821 HS	559 HF
RCW	50 Ronco	83 - 83	532 HF	
RST	50	90 - 90	519 HF	519 HF
RST	50 Sport	87 - 87	574 HF	574 HF
SL	50 Centro	96 - 00	123 HF	2012
V4	50 Olympique	83 - 83	532 HF	
XL	50 Sport	83 - 85	532 HF	
XSM	50	03 - 14	120 HF	105 HF
XSM	50	19 - 23	120 HF	
XTM	50	03 - 11	105 HF	105 HF
XTM	50	19 - 23	120 HF	
	100 Ciak	00 - 01	123 HF	123 HF
F-12	100 Phantom A.C.	00 - 03	123 HF	
F-12	100 Phantom Twin Disk	02 - 03	123 HF	123 HF
	125 Blog	10 - 10	163 CT	102 CT
	125 Centro ie	08 - 11	163 CT	107 CT
	125 Ciak, Ciak Master	02 - 06	123 CT	
	125 Dune	19 - 23	873 HF	544 HF
	125 Dune X	19 - 23	873 HF	544 HF
	125 Madison 3	08 - 09	176 CT	157 CT
	125 Monte	20 - 20	205 CT	102 CT
	125 Monte Pro	19 - 23	873 HF	544 HF
	125 Phantom Max	04 - 08	168 CT	152 CT
	125 Runner	86 - 86	532 HF	
	125 Runner	87 - 87	108 CT	
	125 Sport City Cube	08 - 08	108 CT	152 CT
F-18	125 , Warrior	00 - 02	123 CT	152 CT
GP	125 Spectre	21 - 23	180 CT	225 CT
R	125 Madison	99 - 09	120 CT	152 CT
XSM	125	19 - 23	873 HF	544 HF
XTM	125	19 - 23	873 HF	544 HF
	150 Ciak, Ciak Master	02 - 08	123 CT	
	150 Madison	99 - 03	120 CT	152 CT
F-18	150	00 - 03	123 CT	123 CT
	160 Blog	10 - 11	163 CT	102 CT
	160 Centro ie	08 - 11	163 CT	107 CT
	180 Madison	02 - 02	120 CT	152 CT

**RECOMMENDED**1xx - 2xx = Scooter Pads  
5xx - 9xx = Street, Off Road & Racing Pads  
2xxx = Brake Shoes

MALAGUTI				
	200 Phantom Max	04 - 05	168 CT	152 CT
	200 Sport City Cube	08 - 08	108 CT	152 CT
S	200 Madison	03 - 06	120 CT	152 CT
	250 Madison	99 - 04	159 MS	152 MS
	250 Madison 3 ie	08 - 11	176 CT	157 CT
	250 Password	06 - 08	168 CT	152 CT
	250 Phantom Max	05 - 08	168 CT	152 CT
	250 Sport City Cube	08 - 08	108 MS*	152 MS
RS	250 Madison	05 - 11	168 CT	152 CT
	300 Sport City Cube	08 - 08	108 MS*	152 MS
K	400 Madison	02 - 11	159 MS	152 MS
MGX	425 Ronco	87 - 11	541 HF	
MGX	450 Ronco	87 - 11	595 HF	
GT	500 Spidermax	04 - 10	108 MS*	157 MS
RS	500 Spidermax	09 - 11	108 MS*	157 MS
<b>MALANCA</b>				
E2	80 C80	80 - 80	574 HF*	574 HF
GTI	80	80 - 80	574 HF*	574 HF
	125 Enduro Mark ST 54, GT55	79 - 83	532 HF	
	125 Mark	85 - 85	519 HF	
E2	125	80 - 84	574 HF*	574 HF
E2	125 CS ob one 5N, 6N, Racing	80 - 80	574 HF*	574 HF
E2	125 Sport	80 - 80	574 HF*	574 HF
GTI	125	80 - 80	574 HF*	574 HF
<b>MASH</b>				
	125 Cafe Racer	14 - 16	814 HF	536 HF
	125 Scrambler	13 - 17	585 HF	
	125 Seventy	13 - 17	585 HF	
	125 Seventy Five	14 - 17	814 HF	536 HF
	250 Cafe Racer	14 - 16	814 HF	536 HF
	250 Two Fifty	14 - 17	814 HF	536 HF
	400 Scrambler	13 - 17	627 HS	
	500 Five Hundred	13 - 16	627 HS	
<b>MBK</b>				
	50 Active	89 - 89	2021	2021
	50 AJP Caliper incl. pin/spring	89 - 19	188 HF	
	50 Booster	90 - 94	2050	2050
	50 Booster 12"	03 - 10	123 HF	
	50 Booster Naked	04 - 16	123 HF	
	50 Booster Next Gen.	97 - 06	114 HF	2050
	50 Booster Rocket	95 - 02	114 HF	2050
	50 Booster Spirit	00 - 16	123 HF	2050
	50 Booster Track	97 - 02	114 HF	2050
	50 Champ	91 - 91	2112	2112
	50 Equalis	96 - 98	114 HF	2028
	50 Evasion straight wheels	01 - 01	2194	2194
	50 Evolis	92 - 98	114 HF	2050
	50 Fizz	93 - 00	114 HF	2028
	50 Flipper	99 - 04	123 HF	2050
	50 Forte	94 - 98	114 HF	2028
	50 Hardrock straight wheels	01 - 01	2194	2194
	50 Hot Champ	91 - 97	2021	2050
	50 Mach G	02 - 03	123 HF	
	50 Magnum straight wheels	01 - 01	2194	2194
	50 Nitro	97 - 10	114 HF	145 HF
	50 Ovetto	97 - 10	114 HF	2050
	50 Passion straight wheels	01 - 01	2194	2194
	50 Sorriso	92 - 95	2028	2028
	50 Stunt	00 - 10	145 HF	
	50 Target	92 - 95	111 HF	2028
	50 X-Limit	04 - 16	105 HF	105 HF
	50 X-Power	04 - 13	168 HF	105 HF
	75 Active	90 - 90	2050	2021
	80 Active	89 - 89	2021	2021
	80 Evolis	94 - 98	114 HF	2028
	100 Booster	99 - 02	111 HF	
	100 Nitro	00 - 03	123 HF	
YN	100 Ovetto	00 - 02	123 HF	
	125 Doodo	01 - 05	123 CT	

\* = 2 sets required / 2 jeux pour l'Avant.

Full compound selection, see under "Brake pad 1:1 Drawings" / Sélection complète de composés, voir "1:1 Schémas Plaquettes de frein".



**RECOMMENDED**

1xx - 2xx = Scooter Pads  
5xx - 9xx = Street, Off Road & Racing Pads  
2xxx = Brake Shoes



<b>MBK</b>				
	125 Flame R/F	95 - 03	107 CT	2028
	125 Skyliner	06 - 14	194 CT	157 CT
XC	125 Waap	08 - 12	227 CT	
XQ	125 Thunder	01 - 04	151 CT	157 CT
YP	125 Flame X	05 - 12	190 CT	
YP	125 Skyliner	99 - 00	151 CT	2199
YP	125 Skyliner	01 - 12	151 CT	157 CT
YW	125 Z	10 - 10	208 CT	
	150 Doodo	01 - 01	123 CT	
	150 Skyliner	01 - 03	151 CT	157 CT
	150 Vertex	97 - 97	107 CT	
XQ	150 Thunder	02 - 03	151 CT	157 CT
	180 Skyliner	04 - 07	151 CT	157 CT
	250 Skyliner	00 - 02	128 MS	155 MS
	300 Kilibre	03 - 08	151 MS	151 MS
	400 Skyliner	04 - 04	128 MS	
<b>MBP</b>				
M	502 N	23 - 23	674 HS*	675 LS
C	650 V	23 - 23	627 HS*	657 LS
	1000 C1002V	23 - 23	706 HS*	671 LS
	1000 T1002V	23 - 23	706 HS*	671 LS
<b>MEGELLI</b>				
	125 M, R, S	08 - 10	814 HF	777 HF
<b>MINARELLI</b>				
MR	80	96 - 96	105 HF	
<b>MONDIAL</b>				
	1000 EVO	04 - 04	762 HS*	730 LS
	1000 Piega	03 - 04	762 HS*	730 LS
	1000 RZ Nuda	04 - 04	762 HS*	730 LS
	1000 Starfighter	04 - 04	762 HS*	730 LS
<b>MONTESA</b>				
	125 Cota	88 - 88	559 RSI	559 RSI
	250 Cota 4RT	04 - 16	802 RSI	803 RSI
	260 Evasion	92 - 92	559 RSI	519 RSI
Cota	260 4Ride	16 - 24	939 RSI	803 RSI
Cota	260 4RT	04 - 24	802 RSI	803 RSI
Cota	260 4RT Race Replica	15 - 24	939 RSI	803 RSI
Cota	300 RR	16 - 19	939 RSI	803 RSI
Cota	301 RR	20 - 24	939 RSI	803 RSI
Cota	301 RR Race Replica	20 - 24	939 RSI	803 RSI
	304 Cota	88 - 88	559 RSI	559 RSI
	307 Cota	89 - 89	559 RSI	559 RSI
	307 Cota Trial	88 - 89	559 RSI	559 RSI
	309 Cota	89 - 90	559 RSI	519 RSI
	310 Cota	89 - 92	559 RSI	519 RSI
	311 Cota Trial	92 - 92	559 RSI	519 RSI
	315 Cota R	97 - 04	559 RSI	559 RSI
	335 Cota	87 - 91	559 RSI	559 RSI
	360 315R	01 - 04	802 RSI	803 RSI
H7	360 Enduro	86 - 86	595 HF	
M7	360 Enduro	85 - 85	559 HF	
<b>MORBIDELLI</b>				
	125 cc	76 - 76	559 HF*	559 HF
<b>MORIWAKI</b>				
MD	250	09 - 09	782 DC	618 RQ
<b>MOTOBECANE</b>				
	50 all models	88 - 89	2074	
<b>MOTO-GUZZI</b>				
	125 Custom	85 - 85	519 HF	
	125 Enduro TT	85 - 85	519 HF	
BX	125	92 - 92	519 HF	519 HF
	240 /4	77 - 77	519 HF	
	250 TS	75 - 76	519 HF	



**RECOMMENDED**

1xx - 2xx = Scooter Pads  
5xx - 9xx = Street, Off Road & Racing Pads  
2xxx = Brake Shoes



<b>MOTO-GUZZI</b>				
	350	77 - 81	519 HF*	519 HF
	350 Falco	88 - 88	519 HF	519 HF
	350 Imola	78 - 84	519 HF*	519 HF
	350 Nevada	92 - 97	519 HF*	
NTX	350	88 - 88	519 HF	519 HF
NTX	350	90 - 90	519 HF	506 HF
V35	350 C	82 - 86	506 HF*	519 HF
V35	350 Florida	85 - 86	506 HF*	519 HF
V35	350 GT	77 - 77	519 HF	
V35	350 GT	90 - 90	506 HF	519 HF
V35	350 II, Imola, Imola II	77 - 77	519 HF*	519 HF
V35	350 III	87 - 87	506 HF*	506 HF
V35	350 TT	86 - 86	506 HF*	506 HF
	400	77 - 84	519 HF*	519 HF
	500	77 - 80	519 HF*	519 HF
	500 Monza	78 - 85	519 HF*	519 HF
V50	500 1,2,3, Monza Chopper	77 - 77	519 HF*	519 HF
	650	80 - 84	519 HF*	519 HF
	650 Florida	85 - 84	519 HF*	519 HF
GT	650 Sessantacinque	89 - 89	519 HF*	519 HF
NTX	650	90 - 02	519 HF	506 HF
V65	650 Florida	86 - 94	506 HF*	506 HF
V65	650 GT	90 - 94	506 HF	598 HF
V65	650 Lario	86 - 94	519 HF*	519 HF
V65	650 NTX	87 - 02	519 HF	519 HF
V65	650 SP, Chopper	80 - 84	519 HF*	519 HF
V65	650 TT	86 - 94	519 HF*	519 HF
	750 Brevia	03 - 09	706 HS	730 LS
	750 Ippogrifo	97 - 97	566 HF	519 HF
	750 Nevada	92 - 96	519 HF*	
	750 Nevada Classic ie	06 - 11	706 HF	730 HF
	750 Nevada, Club/Base	97 - 02	519 HF*	519 HF
	750 Nevada, Nevada Club	03 - 16	706 HF	730 HF
	750 Targa	89 - 89	519 HF*	519 HF
NTX	750	89 - 89	519 HF	519 HF
NTX	750	90 - 93	596 HS	506 LS
S3	750	75 - 76	506 HF*	
SP	750	91 - 92	506 HS	506 LS
V7	750 Cafe Classic	10 - 13	706 HS	730 LS
V7	750 Classic	09 - 12	706 HS*	730 LS
V7	750 Clubman Racer	10 - 10	706 HS*	730 LS
V7	750 Racer	11 - 11	706 HS	730 LS
V7	750 Racer	12 - 14	706 HS	588 HF
V7	750 Stone	12 - 14	706 HS	588 HF
V7 II	750 Racer	15 - 16	706 HS	588 HF
V7 II	750 Scrambler	16 - 16	706 HS	588 HF
V7 II	750 Special	15 - 16	706 HS	588 HF
V7 II	750 Stone	15 - 16	706 HS	588 HF
V7 II	750 Stornello	16 - 16	706 HS	588 HF
V7 II	750 Stornello Ltd. Edition	17 - 18	706 HS	588 HF
V7 III	750 Anniversario	17 - 18	706 HS	588 HF
V7 III	750 Carbon	18 - 19	706 HS	588 HF
V7 III	750 Euro 4	17 - 19	706 HS	588 HF
V7 III	750 Limited	19 - 19	706 HS	588 HF
V7 III	750 Milano	18 - 20	706 HS	588 HF
V7 III	750 Racer	17 - 20	706 HS	588 HF
V7 III	750 Rough	18 - 20	706 HS	588 HF
V7 III	750 Special	17 - 19	706 HS	588 HF
V7 III	750 Stone	17 - 20	706 HS	588 HF
V75	750	86 - 88	506 HF*	506 HF
V75	750 Duna	86 - 90	506 HF	506 HF
V75	750 TT Paris-Dakar	86 - 86	506 HF	506 HF
	850 Brevia	06 - 09	706 HS*	730 LS
	850 Le Mans	76 - 79	506 HF*	506 HF
T	850	74 - 76	506 HF	
T3	850	75 - 80	506 HF*	506 HF
T4	850	75 - 82	506 HF*	506 HF
T5	850	75 - 88	506 HF*	506 HF
T5	850 N.T.	86 - 88	506 HF*	506 HF
V7	850 Special	22 - 23	706 HS	588 HF
V7	850 Stone	22 - 23	706 HS	588 HF
V7	850 Stone Fast Endurance	22 - 22	706 HS	588 HF

\* = 2 sets required / 2 jeux pour l'Avant.

Full compound selection, see under "Brake pad 1:1 Drawings" / Sélection complète de composés, voir "1:1 Schémas Plaquettes de frein".



**RECOMMENDED**

1xx - 2xx = Scooter Pads  
 5xx - 9xx = Street, Off Road & Racing Pads  
 2xxx = Brake Shoes

**MOTO-GUZZI**

V7	850 Stone Special Edition	23 - 23	706 HS	588 HF
V85	850 TT	19 - 23	706 HS*	588 HF
V85	850 TT Evocative Graphics	23 - 23	706 HS*	588 HF
V85	850 TT Guardia d'Onore	22 - 23	706 HS*	588 HF
V85	850 TT Travel	20 - 23	706 HS*	588 HF
V9	850 Bobber	16 - 17	706 HS	588 HF
V9	850 Bobber Sports	19 - 20	706 HS	588 HF
V9	850 Roamer	16 - 17	706 HS	588 HF
V9	850 X-Track	17 - 17	706 HS	588 HF
	940 Custom	07 - 07	706 HS*	674 LS
	1000	81 - 83	554 HF*	554 HF
	1000 California II	85 - 88	506 HF*	506 HF
	1000 California III C	91 - 95	506 HS*	506 LS
	1000 California III, Fuel Injection	89 - 89	506 HF*	506 HF
	1000 Daytona	91 - 02	566 HF*	506 HF
	1000 Le Mans IV	85 - 89	506 HF*	506 HF
	1000 Le Mans, V	90 - 98	506 HS*	506 LS
	1000 Quota	92 - 92	566 HF*	614 HF
GT	1000 V	91 - 91	506 HS*	506 LS
RS	1000 Daytona	97 - 00	566 HF*	519 HF
S	1000	90 - 90	506 HS*	506 LS
SP	1000 III	91 - 94	506 HS*	506 LS
SP	1000 Le Mans	79 - 83	506 HF*	554 HF
V	1000 Strada	93 - 94	506 HF*	519 HF
V10	1000 Centauro	96 - 00	566 HF*	519 HF
V100	1042 Mandello	22 - 23	900 HS*	671 LS
V100	1042 S Mandello	23 - 23	900 HS*	671 LS
V100	1042 Stelvio	24 - 24	900 HS*	671 LS
	1100 California	96 - 99	506 HS*	506 LS
	1100 California EV	06 - 06	706 HS	674 LS
	1100 California EV Touring	06 - 06	706 HS	674 LS
	1100 California Jackal	00 - 00	566 HF*	674 HF
	1100 California Jackal	01 - 06	706 HS*	674 LS
	1100 California Jackal Basic	00 - 00	566 HF	674 HF
	1100 California Jackal Basic	01 - 06	706 HS	674 LS
	1100 California Special	99 - 00	566 HF*	674 HF
	1100 California Special	01 - 01	706 HS*	674 LS
	1100 California Special Sport Alloy	02 - 06	706 HS*	674 LS
	1100 California Stone Metal	02 - 03	706 HS	674 LS
	1100 California Stone, Stone Touring	02 - 05	706 HS	674 LS
	1100 California Titanium	03 - 05	706 HS*	674 LS
	1100 California Vintage	06 - 13	706 HS*	674 LS
	1100 Griso	05 - 10	706 HS	674 LS
	1100 Sport	96 - 04	566 HF*	519 HF
ES	1100 Quota	99 - 03	674 HF*	671 HF
EV	1100 California	97 - 00	566 HF*	519 HF
EV	1100 California, 80, Touring	01 - 01	706 HS*	519 LS
V	1100 Breva	04 - 04	706 HS	730 LS
V	1100 Breva, ABS	05 - 07	706 HS	671 LS
V11	1100 , Scura, Sport Scura	02 - 05	706 HS*	519 LS
V11	1100 Lemans, Lemans Tenni, Lemans Rosso Corsa	01 - 06	706 HS*	519 LS
V11	1100 Sport	97 - 00	566 HF*	519 HF
V11	1100 Sport Rosso Mandell	01 - 06	706 HS*	519 LS
V11	1100 Sport, Sport Naked	01 - 05	706 HS*	519 LS
	1200 Griso 8V	07 - 13	706 HS*	671 LS
	1200 MGS-01 Corsa	05 - 13	762 HS*	730 LS
	1200 Norge	06 - 14	706 HS*	671 LS
	1200 Norge GT 8V	10 - 13	706 HS*	671 LS
	1200 Sport	07 - 08	706 HS*	671 LS
	1200 Sport 4V	09 - 11	706 HS*	730 LS
	1200 Sport 8V	12 - 13	706 HS*	671 LS
	1200 Sport 8V SE	12 - 15	706 HS*	671 LS
	1200 Stelvio	08 - 11	706 HS*	671 LS
	1200 Stelvio 8V SE	12 - 16	706 HS*	671 LS
	1200 Stelvio NTX	09 - 11	706 HS*	671 LS
V	1200 Breva	08 - 13	706 HS	671 LS
	1400 Audace	15 - 17	706 HS*	674 LS
	1400 California Custom	13 - 15	706 HS*	674 LS
	1400 California Touring	13 - 15	706 HS*	674 LS
	1400 California Touring SE	16 - 17	706 HS*	674 LS
	1400 Eldorado	15 - 17	706 HS*	674 LS

**RECOMMENDED**

1xx - 2xx = Scooter Pads  
 5xx - 9xx = Street, Off Road & Racing Pads  
 2xxx = Brake Shoes

**MOTO-GUZZI**

MGX-21	1400 Flying Fortress	15 - 17	706 HS*	674 LS
<b>MOTOM</b>				
	50 Spasso	08 - 09	211 HF	
<b>MOTO-MORINI</b>				
	125 KJ	84 - 88	606 HF	
	125 Strada	80 - 80	560 HF	
	250 Strada	80 - 80	560 HF	
XE	250 Country	88 - 88	519 HF	
	350 Coguaro	90 - 95	608 HF	519 HF
	350 Coguaro, New York	90 - 94	608 HF	519 HF
	350 Dart	88 - 88	608 HF	519 HF
	350 Dart	90 - 92	641 HF	519 HF
	350 Excalibur	86 - 86	594 HF	594 HF
	350 Excalibur	87 - 89	588 HF	606 HF
	350 Indiana	88 - 88	594 HF	519 HF
	350 K2	84 - 87	560 HF	606 HF
	350 Kanguro	88 - 88	588 HF	519 HF
	350 Strada	76 - 81	560 HF	
RLX	350 Excalibur	90 - 92	608 HF	519 HF
	400 Dart	89 - 89	608 HF	519 HF
	400 Dart	90 - 92	641 HF	519 HF
	400 S	82 - 82	519 HF*	519 HF
	500 Sei V Classic	89 - 89	519 HF*	
	500 Strada	80 - 82	560 HF	
	501 Camel	88 - 88	588 HF	519 HF
	501 Coguaro	89 - 89	608 HF	519 HF
	501 New York	89 - 89	594 HF	519 HF
RLX	501 Excalibur	86 - 86	594 HF	594 HF
RLX	501 Excalibur	87 - 87	588 HF	606 HF
RLX	501 Excalibur	88 - 89	594 HF	519 HF
RLX	501 Excalibur	90 - 90	608 HF	519 HF
	649 X-Cape	20 - 23	674 HS*	730 LS
	650 Calibro	24 - 24	674 HS	675 LS
	650 Indiana	88 - 88	594 HF	519 HF
	650 Seiemmezzo	20 - 23	674 HS*	671 LS
	750 Corsaro	24 - 24	841 HS*	730 LS
	750 Corsaro Sport	24 - 24	841 HS*	730 LS
	750 Indiana	88 - 88	594 HF	519 HF
	1200 11 1/2	18 - 18	706 HS*	730 LS
	1200 9 1/2	06 - 09	706 HS*	730 LS
	1200 Corsaro	06 - 13	706 HS*	730 LS
	1200 Corsaro ZT	20 - 20	901 HS*	730 LS
	1200 Corsaro ZZ	18 - 20	901 HS*	730 LS
	1200 Granferro	10 - 10	762 HS*	671 LS
	1200 Granpasso	08 - 13	674 HS*	671 LS
	1200 GT	10 - 10	674 HS*	671 LS
	1200 Milano	18 - 24	901 HS*	730 LS
	1200 Scrambler	09 - 10	674 HS*	671 LS
	1200 Scrambler	18 - 18	901 HS*	730 LS
	1200 Sport	08 - 13	706 HS*	730 LS
	1200 Super Scrambler	20 - 20	901 HS*	730 LS
	1200 X-Cape	24 - 24	841 HS*	730 LS
<b>MOTOR UNION</b>				
JC	125 2B Deer	98 - 99	690 HF	
HK	250 Haoke	97 - 99	638 HF	
<b>MOTORHISPANIA</b>				
	50 AJP Caliper incl. pin/spring	89 - 19	188 HF	
MH	50 Furia 6v	99 - 99	105 HF	105 HF
MH	50 Furia Max	06 - 10	105 HF	105 HF
MH	50 Urban Bike	06 - 10	168 HF	105 HF
RX	50 R	08 - 14	189 MS	203 HF
RX	50 Racing	00 - 05	148 HF	105 HF
RYZ	50 Enduro	05 - 13	105 HF	105 HF
RYZ	50 Supermotard	05 - 10	186 HF	105 HF
MH7	125 Naked	08 - 14	821 HS	585 HF
RX	125 R	08 - 14	821 HS	585 HF
RYZ	125 Arena Enduro	05 - 07	559 HF	559 HF

\* = 2 sets required / 2 jeux pour l'Avant.

Full compound selection, see under "Brake pad 1:1 Drawings" / Sélection complète de composés, voir "1:1 Schémas Plaquettes de frein".



**RECOMMENDED**

1xx - 2xx = Scooter Pads  
 5xx - 9xx = Street, Off Road & Racing Pads  
 2xxx = Brake Shoes



**MOTRON**

	50 Spike	97 - 98	123 HF	
	50 Sting	95 - 98	123 HF	
	50 Syncro	97 - 98	123 HF	
	50 Thunder	95 - 98	123 HF	
GL4	50 ID Flash	92 - 92	532 HF	
GTD	50 Italian Max, 2	92 - 92	532 HF	
RZ1	50 Compact	92 - 92	532 HF	

**MV AGUSTA**

	550 Lucky Explorer	23 - 23	841 HS*	671 LS
	675 Brutale	12 - 15	706 HS*	730 LS
F3	675	11 - 12	706 HS*	763 LS
F3	675	13 - 14	706 HS*	730 LS
F3	675	15 - 20	901 HS*	730 LS
F3	675 RC	16 - 20	901 HS*	730 LS
	750 Brutale, Brutale S	01 - 05	676 HS*	763 LS
F4	750	99 - 02	676 HS*	763 LS
F4	750 SPR	01 - 03	676 HS*	763 LS
	800 Brutale	13 - 20	706 HS*	730 LS
	800 Brutale Dragster	15 - 19	706 HS*	730 LS
	800 Brutale Dragster RC	17 - 20	706 HS*	730 LS
	800 Brutale Dragster RR	15 - 19	706 HS*	730 LS
	800 Brutale Dragster RR LH44	18 - 20	706 HS*	730 LS
	800 Brutale Dragster RR Pirelli	18 - 20	706 HS*	730 LS
	800 Brutale RC	18 - 20	706 HS*	730 LS
	800 Brutale Rosso	20 - 21	706 HS*	730 LS
	800 Brutale RR	16 - 20	706 HS*	730 LS
	800 Dragster Rosso	20 - 21	706 HS*	730 LS
	800 Rivale	13 - 17	900 HS*	730 LS
	800 RVS#1	18 - 20	706 HS*	730 LS
	800 Stradale	15 - 16	900 HS*	730 LS
	800 Superveloce	19 - 19	841 HS*	730 LS
	800 Superveloce	20 - 22	901 HS*	730 LS
	800 Turismo Veloce	14 - 19	900 HS*	730 LS
	800 Turismo Veloce Lusso	14 - 20	900 HS*	730 LS
	800 Turismo Veloce Lusso Scs	18 - 21	900 HS*	730 LS
	800 Turismo Veloce RC	17 - 20	900 HS*	730 LS
	800 Turismo Veloce Rosso	20 - 21	900 HS*	730 LS
F3	800	14 - 20	901 HS*	763 LS
F3	800 AMG GT	16 - 20	841 HS*	730 LS
F3	800 RC	16 - 20	901 HS*	730 LS
F3	800 RR	21 - 23	841 HS*	730 LS
	910 Brutale	06 - 08	676 HS*	763 LS
	910 Brutale R	06 - 08	762 HS*	763 LS
	910 Brutale S	06 - 08	676 HS*	763 LS
	920 Brutale	12 - 14	706 HS*	763 LS
	950 9.5 LXP Orioli	24 - 24	841 HS*	730 LS
	950 Lucky Explorer	23 - 23	841 HS*	671 LS
	989 Brutale R	09 - 09	706 HS*	763 LS
	990 Brutale R	10 - 11	706 HS*	763 LS
	1000 Brutale RR	20 - 20	841 HS*	730 LS
	1000 Rush	20 - 20	841 HS*	730 LS
F4	1000 LH44	18 - 20	841 HS*	763 LS
F4	1000 Mamba	04 - 06	676 HS*	763 LS
F4	1000 R	06 - 07	762 HS*	763 LS
F4	1000 R	12 - 19	841 HS*	763 LS
F4	1000 RC	15 - 20	841 HS*	763 LS
F4	1000 RR	12 - 20	841 HS*	763 LS
F4	1000 S	04 - 06	676 HS*	763 LS
F4	1000 Tamburini	04 - 06	676 HS*	763 LS
	1078 Brutale RR	09 - 09	841 HS*	763 LS
F4	1078 312 RR	08 - 11	841 HS*	763 LS
F4	1078 CC	08 - 11	841 HS*	763 LS
	1090 Brutale Corse	14 - 16	841 HS*	763 LS
	1090 Brutale R	12 - 15	706 HS*	763 LS
	1090 Brutale RR	10 - 17	841 HS*	763 LS

**MZ**

	50 (MUZ) Moskito	99 - 02	111 HF	
	50 (MUZ) Moskito SX	00 - 02	101 HF	
	125 (MUZ) Moskito	99 - 02	111 CT	
	125 Mantizz S	07 - 07	103 CT	



**RECOMMENDED**

1xx - 2xx = Scooter Pads  
 5xx - 9xx = Street, Off Road & Racing Pads  
 2xxx = Brake Shoes



**MZ**

	125 Roadstar	92 - 94	506 HF	
	125 SM, SX	99 - 01	681 HF	633 HF
	125 SM, SX	02 - 08	713 HF	633 HF
	125 Sportstar	93 - 98	506 HF	
ETZ	125	82 - 84	506 HF	2172
ETZ	125	85 - 92	506 HF	
ETZ	125	85 - 92	2172	2172
RT	125	06 - 08	633 HF	633 HF
TS	125	73 - 85	2171	2172
ETZ	150	82 - 84	506 HF	2172
ETZ	150	85 - 92	2172	2172
ETZ	150	85 - 95	506 HF	
TS	150	73 - 85	2171	2172
ETZ	250	82 - 84	506 HF	2171
ETZ	250	85 - 92	2171	2171
TS	250	73 - 81	2171	2171
	251 (MUZ) Sportstar	96 - 98	506 HF	
	251 Saxon Tour	93 - 98	506 HF	
ETZ	251	89 - 89	506 HF	
ETZ	300 LUX	90 - 90	506 HF	
ETZ	300 X	88 - 88	506 HF	
	301 (MUZ) Sportstar	96 - 98	506 HF	
	301 Saxon Tour	93 - 98	506 HF	
ETZ	301	90 - 92	506 HF	
	500 Saxon Country	92 - 98	506 HF	
	500 Saxon Fun	92 - 98	506 HF	
	500 Saxon Voyager	93 - 98	506 HF	
	500 Silver Star Classic	93 - 98	506 HF	
	660 (MUZ) Baghira	96 - 00	681 HF	684 HF
	660 (MUZ) Black Panther	00 - 06	681 HF	684 HF
	660 (MUZ) Mastiff	96 - 06	681 HF	684 HF
	660 (MUZ) Skorpion Cup	99 - 99	566 HF	519 HF
	660 (MUZ) Skorpion Replica	97 - 99	566 HF*	519 HF
	660 (MUZ) Skorpion Sport	95 - 99	566 HF	519 HF
	660 (MUZ) Skorpion Tour	95 - 00	566 HF	519 HF
	660 (MUZ) Skorpion Traveller	99 - 00	566 HF	519 HF
	660 (MUZ) Street Moto	00 - 06	681 HF	684 HF
	660 (MUZ) Super Moto	07 - 07	681 HF	684 HF
	1000 (MUZ) S	01 - 02	706 HS*	691 HF
	1000 (MUZ) S	03 - 10	624 HS*	715 LS
	1000 (MUZ) SF	05 - 10	624 HS*	715 LS
	1000 (MUZ) SFX	07 - 07	624 HS*	715 LS
	1000 (MUZ) SN	05 - 05	624 HS*	715 LS
	1000 (MUZ) ST	07 - 10	624 HS*	715 LS

**NIU**

	RQi	24 - 24	900 HS	730 LS
--	-----	---------	--------	--------

**NORTON**

	600 Commander	90 - 90	506 HF*	506 HF
	600 Interpol	83 - 88	506 HF*	506 HF
	600 Wankel Classic	88 - 89	506 HF*	506 HF
F-1	600	90 - 90	566 HF*	506 HF
TT	600	92 - 92	566 HF*	
MK2	850 Commando	73 - 75	505 HF	
MK3	850 Commando	75 - 77	505 HF	505 HF
	961 Commando Cafe Racer	11 - 14	762 HS*	730 LS
	961 Commando Cafe Racer MKII	18 - 19	900 HS*	730 LS
	961 Commando SE	10 - 11	706 HS*	730 LS
	961 Commando SE	12 - 14	762 HS*	730 LS
	961 Commando SF	13 - 15	762 HS*	730 LS
	961 Commando SF Sport	11 - 15	706 HS*	730 LS
	961 Commando Sport	18 - 19	900 HS*	730 LS
	961 Dominator Naked	17 - 19	900 HS*	730 LS
	1200 V4 RR	18 - 19	841 HS*	730 LS

**OHVALE**

GP-0	110	17 - 23	885 RST	872 RQ
GP-0	160	17 - 23	885 RST	872 RQ
GP-0	190	17 - 23	885 RST	872 RQ
GP-2	190	21 - 24	962 RST	548 HF
GP-0	212	17 - 19	872 RST*	872 RQ

\* = 2 sets required / 2 jeux pour l'Avant.

Full compound selection, see under "Brake pad 1:1 Drawings" / Sélection complète de composés, voir "1:1 Schémas Plaquettes de frein".

**RECOMMENDED**1xx - 2xx = Scooter Pads  
5xx - 9xx = Street, Off Road & Racing Pads  
2xxx = Brake Shoes

OSSA					
TR	125 i	15 - 15	802 RSI	803 RSI	
TR	250 i	15 - 15	802 RSI	803 RSI	
TR	280 i	10 - 15	802 RSI	803 RSI	
TR	280 i Explorer	12 - 15	802 RSI	803 RSI	
TR	300 Factory R	15 - 15	939 RSI	803 RSI	
TR	300 i	15 - 15	802 RSI	803 RSI	
	350 TU-YO	82 - 82	532 HF		
	500 Yanqee	78 - 78	506 HF	519 HF	
PETERSON					
	50 Hurricane	95 - 95	111 HF	101 HF	
SR	50 Racing	95 - 95	111 HF	101 HF	
	80 Hurricane	95 - 95	111 HF	101 HF	
SR	80 Racing	95 - 95	111 HF	101 HF	
PEUGEOT					
	e-Vivacity	11 - 15	141 HF	2012	
	50 103	71 - 75	2074	2074	
	50 104	76 - 76	2074	2074	
	50 105	82 - 82	2074	2074	
	50 AJP Caliper incl. pin/spring	89 - 19	188 HF		
	50 Blaster	09 - 12	105 HF		
	50 Blaster Furios	11 - 12	105 HF	105 HF	
	50 Blaster RS12	09 - 12	105 HF		
	50 Buxy (A.J.P. cal.)	94 - 97	105 HF	2012	
	50 Buxy (Brembo cal.)	94 - 97	123 HF	2012	
	50 Buxy (Hengtong cal.)	94 - 97	102 HF	2012	
	50 CityStar	14 - 16	177 HF	157 HF	
	50 Django Allure	14 - 16	205 HF		
	50 Django Evasion	14 - 16	205 HF		
	50 Django Heritage	14 - 16	197 HF		
	50 Django Sport	14 - 16	205 HF		
	50 Elyseo	02 - 05	105 HF	105 HF	
	50 Elyseo (A.J.P. cal.)	99 - 01	105 HF	2012	
	50 Elystar	03 - 05	105 HF	167 HF*	
	50 Jet C-Tech	09 - 09	105 HF	105 HF	
	50 Jet-Force	03 - 10	105 HF	105 HF	
	50 Kisbee	10 - 14	102 HF		
	50 Kisbee RS	11 - 17	102 HF		
	50 Looxor	02 - 05	105 HF	2012	
	50 Looxor	06 - 06	105 HF	105 HF	
	50 Ludix	04 - 08	105 HF	2012	
	50 Ludix (Drum front)	04 - 05	2012	2012	
	50 Metropolis	85 - 90	2012	2011	
	50 Rapido	85 - 93		2011	
	50 Speedake (A.J.P. cal)	94 - 01	105 HF	2012	
	50 Speedake (Brembo cal.)	94 - 01	123 HF	2012	
	50 Speedake (Hengtong cal.)	94 - 01	102 HF	2012	
	50 Speedfight 2 A/C	01 - 08	105 HF		
	50 Speedfight 2 L/C	01 - 08	105 HF	105 HF	
	50 Speedfight 2 X-Race, Furious, 206 WRC	01 - 02	105 HF	105 HF	
	50 Speedfight 3 (AC)	10 - 16	200 HF	2012	
	50 Speedfight 3 (LC)	10 - 16	200 HF	157 HF	
	50 Speedfight 3 RS (LC)	10 - 16	200 HF	157 HF	
	50 Speedfight 4 (AC)	15 - 16	200 HF		
	50 Speedfight 4 (LC)	15 - 16	200 HF	157 HF	
	50 Speedfight LBD/LBDP	00 - 00	105 HF	105 HF	
	50 Speedfight LC,(A.J.P. cal.)	96 - 15	105 HF	2012	
	50 Speedfight LC,(Brembo cal.)	96 - 15	123 HF	2012	
	50 Speedfight LC,(Hengtong cal.)	96 - 15	102 HF	2012	
	50 Speedfight Lemans	11 - 11	105 HF	105 HF	
	50 Squab (A.J.P. cal.)	94 - 04	105 HF	2012	
	50 Squab (Hengtong cal.)	94 - 04	102 HF	2012	
	50 TKR Furious	05 - 10	105 HF		
	50 TKR WRC	05 - 10	105 HF		
	50 Trekker Metal-X	01 - 08	105 HF		
	50 Trekker Offroad	99 - 01	102 HF		
	50 Trekker Road	99 - 00	105 HF	2012	
	50 Trekker Streetboard	00 - 02	105 HF		
	50 Trekker Urban Black	00 - 00	105 HF		
	50 Tweet	10 - 13	140 HF	2012	

**RECOMMENDED**1xx - 2xx = Scooter Pads  
5xx - 9xx = Street, Off Road & Racing Pads  
2xxx = Brake Shoes

PEUGEOT					
	50 Tweet Evo	14 - 15	140 HF		
	50 Tweet Evo RS	14 - 17	140 HF	202 HF	
	50 Tweet RS	10 - 13	140 HF	202 HF	
	50 V-Clic	08 - 13	111 HF	2012	
	50 Vivacity	08 - 14	100 HF		
	50 Vivacity (A.J.P. cal.)	99 - 07	105 HF		
	50 Vivacity (Hengtong cal.)	05 - 07	102 HF		
	50 Vivacity Sportline	11 - 11	141 HF		
	50 Zenith	94 - 01	2011		2012
	50 Zenith Luxe	94 - 00	123 HF		2012
SC	50	85 - 90	2012		2011
ST	50	98 - 99	2010		2011
STL 2	50	90 - 94	2010		2011
SV	50 APS	91 - 91	2012		2012
SV	50 Geo	91 - 91	2012		2012
SV	50 Geo	92 - 92	116 HF		2012
SV	50 Geo	93 - 99	121 HF		2012
SV	50 J,Junior	93 - 97	2012		2012
SV	50 L	93 - 93	121 HF		2012
SV	50 Roland Garros	93 - 93	113 HF		2012
SV	50 Sport	93 - 93	113 HF		2012
SX	50	75 - 80	2012		
XP 6	50 Enduro	06 - 12	105 HF		105 HF
XP 6	50 Supermotard	06 - 12	105 HF		105 HF
XP 6	50 Trail	04 - 05	105 HF		105 HF
XP S-6	50 Enduro	02 - 05	105 HF		105 HF
XP S-6	50 Supermotard	04 - 05	168 HF		105 HF
XPLD	50 AV	90 - 90	607 HF		
XR 6	50 Race Spec	02 - 07	148 HF		105 HF
XR 7	50	08 - 10	189 MS		105 HF
SC	75	74 - 77	2012		2011
SX	75	74 - 77	2012		2011
	80 Metropolis	80 - 80	2012		2011
SC	80	76 - 79	2012		2012
SV	80	96 - 98	141 HF		
SV	80 Geo	91 - 92	116 HF		2012
SV	80 Geo	93 - 98	121 HF		2012
SX	80	85 - 94	2012		2011
SX	80 Pro	85 - 94	2012		2011
	100 Elyseo	02 - 05	105 HF		105 HF
	100 Elyseo (A.J.P. cal.)	99 - 01	105 HF		2012
	100 Looxor	02 - 07	105 HF		105 HF
	100 Speedfight	00 - 07	105 HF		105 HF
	100 Speedfight 2, X-Race	01 - 07	105 HF		105 HF
	100 Trekker Road	99 - 04	105 HF		
	100 Vivacity (A.J.P. cal.)	99 - 07	105 HF		
	100 Vivacity (Hengtong cal.)	05 - 07	102 HF		
	125 Active	13 - 13	177 CT		157 CT
	125 CityStar	11 - 15	177 CT		157 CT
	125 Django Allure	14 - 16	205 CT		135 CT
	125 Django Evasion	14 - 16	205 CT		135 CT
	125 Django Heritage	14 - 16	197 CT		157 CT
	125 Django Sport	14 - 16	205 CT		135 CT
	125 Elyseo	00 - 07	168 CT		167 CT
	125 Elyseo (A.J.P. cal.)	99 - 99	105 CT		
	125 Elystar	03 - 07	168 CT		167 CT
	125 Geopolis	06 - 09	177 CT		167 CT
	125 Geopolis (Nissin cal.)	07 - 09	197 CT		197 CT
	125 Jet-Force Compressor	03 - 04	168 CT		167 CT
	125 Looxor	03 - 07	156 CT		167 CT
	125 Ludix	04 - 05	105 CT		2012
	125 Pulsion Active	19 - 22	205 CT		135 CT
	125 Pulsion Allure	19 - 22	205 CT		135 CT
	125 Pulsion RS	19 - 22	205 CT		135 CT
	125 Satelis	04 - 05	105 CT		167 CT
	125 Satelis	06 - 16	168 CT		167 CT
	125 Satelis ABS	04 - 08	183 CT		167 CT
	125 Satelis Black Ed.	17 - 17	205 CT		
	125 Tweet	10 - 13	140 CT		2034
	125 Tweet Evo	14 - 17	140 HF		202 HF
	125 Tweet Evo RS	14 - 16	140 HF		202 HF
	125 Tweet RS	10 - 13	140 CT		202 CT

\* = 2 sets required / 2 jeux pour l'Avant.

Full compound selection, see under "Brake pad 1:1 Drawings" / Sélection complète de composants, voir "1:1 Schémas Plaquettes de frein".





**RECOMMENDED**

1xx - 2xx = Scooter Pads  
5xx - 9xx = Street, Off Road & Racing Pads  
2xxx = Brake Shoes



**PEUGEOT**

	125 Vivacity	10 - 16	197 CT	
GT	125 Satelis Sport	11 - 12	197 CT	197 CT
LXR	125	10 - 13	140 CT	201 CT
RS	125 Geopolis	10 - 13	177 CT	167 CT
SV	125 C Executive	96 - 98	121 HF	2012
SV	125 Executive	94 - 95	121 HF	2012
SV	125 Geo	91 - 92	116 CT	2012
SV	125 Geo	93 - 98	121 HF	2012
XPS	125 CT	06 - 07	559 HF	559 HF
	150 Django Allure	14 - 15	205 CT	135 CT
	150 Django Evasion	14 - 15	205 CT	135 CT
	150 Django Heritage	14 - 15	197 CT	157 CT
	150 Django Sport	14 - 15	205 CT	135 CT
	150 Elyseo	00 - 04	168 CT	167 CT
	150 Elystar	03 - 04	168 CT	167 CT
	150 Tweet	10 - 13	140 CT	2034
	150 Tweet RS	10 - 13	140 CT	202 CT
	200 CityStar	13 - 16	177 CT	157 CT
LXR	200	10 - 11	140 CT	201 CT
	250 Geopolis (AJP cal.)	06 - 11	168 CT	167 CT
	250 Geopolis (Nissin cal.)	06 - 11	197 MS	197 MS
	250 Satelis	06 - 11	177 MS	177 MS
	300 Geopolis GT	14 - 16	183 MS*	197 MS
	300 Geopolis Premium (Nissin cal.)	10 - 13	197 MS	197 MS
	300 Geopolis RS (Nissin cal.)	10 - 14	197 MS	197 MS
	300 Geostyle (Nissin cal.)	10 - 12	197 MS	197 MS
	300 Satelis	13 - 16	197 MS	197 MS
PM-01	300	23 - 23	933 HS	832 LS
	400 Geopolis (AJP cal.)	07 - 12	168 CT	167 CT
	400 Geopolis (Nissin cal.)	07 - 12	197 MS	197 MS
	400 Geopolis GT	14 - 15	183 MS*	197 MS
	400 Geopolis RS	08 - 16	183 MS	197 MS
	400 Metropolis	15 - 16	219 MS*	219 MS
	400 Satelis i	14 - 16	183 MS*	197 MS
XP	400	23 - 23	214 MS	195 MS
	500 Satelis	06 - 06	157 MS*	157 MS
	500 Satelis	07 - 11	183 MS*	197 MS
	600 Satelis ABS	04 - 12	183 CT	167 CT

**PGO**

	i-Dep	09 - 09	140 HF	
	50 Big Max	94 - 02	111 HF	2188
	50 Big Max	03 - 17	101 HF	
	50 Big Max Sport	96 - 04	111 HF	2188
	50 Bugrider	06 - 06	855 HF*	536 HF
	50 Comet	91 - 92	101 HF	2188
	50 Comet	93 - 97	111 HF	2188
	50 Dr. Big	01 - 06	140 HF	
	50 EPS	96 - 97	111 HF	
	50 Galaxy	91 - 97	101 HF	2188
	50 G-Max	06 - 17	140 HF	
	50 G-Max Doppler	06 - 06	138 HF	
	50 Hot	97 - 09	111 HF	
	50 Libra	10 - 10	140 HF	
	50 Ligero	06 - 11	140 HF	
	50 Mega	96 - 99	111 HF	
	50 Road 66	95 - 95	101 HF	
	50 Rodoshow	01 - 09	114 HF	
	50 Star	91 - 93	2012	2011
	50 Tornado	96 - 02	111 HF	
	50 T-Rex	99 - 06	140 HF	
	50 T-Rex 3 (TR3-50)	02 - 16	104 HF	
	50 X-Rider	03 - 10		544 SI
PMS	50	99 - 03	140 HF	
PMX	50	97 - 03	111 HF	
PMX	50 Naked	06 - 08	140 HF	
PMX	50 Sport	01 - 08	140 HF	
PS	50	93 - 93	101 HF	2188
	80 Big Max	94 - 98	111 HF	
	80 Star	91 - 95	2012	2011
	90 Big Max	97 - 06	111 HF	
	90 Galaxy	92 - 94	101 HF	2188



**RECOMMENDED**

1xx - 2xx = Scooter Pads  
5xx - 9xx = Street, Off Road & Racing Pads  
2xxx = Brake Shoes



**PGO**

	90 Rodoshow	02 - 06	114 HF	
	90 Tornado	00 - 00	111 HF	
	100 Big Max	96 - 99	111 HF	2188
	100 My Bubu	02 - 05	140 HF	
	110 T-Rex	99 - 07	140 HF	
PMX	110	00 - 01	111 HF	
	125 Charge A, B	02 - 02	140 CT	
	125 I-Charge Fuel Injection	03 - 08	163 CT	
	125 Kung Fu	00 - 00		111 CT
	125 Libra	10 - 12	197 CT	
	125 Ligero	06 - 11	140 CT	
	125 My Bubu, Young Bubu	02 - 05	140 CT	
	125 Tornado	96 - 97	111 CT	
	125 T-Rex (2 stroke)	99 - 16	140 CT	
	125 T-Rex (4 stroke)	99 - 02	140 CT	
	125 X-Hot	10 - 11	197 CT	
	125 X-Rider	03 - 10		544 SI
	150 TR3	02 - 04	140 CT	
	150 T-Rex	01 - 06	140 CT	2181
	150 X-Rider	03 - 10		544 SI
BR	150 Bugxter	05 - 07	855 HF*	536 HF
BR	200 Bugrider	07 - 07	855 HF*	848 HF
	250 G-Max	06 - 07	566 HF	
BR	250 Bugrider	05 - 12	855 HF*	848 HF
	500 Bug	08 - 14	878 HF*	810 HF
BR	500 i Racer	07 - 08	878 HF*	810 HF
	<b>PIAGGIO VESPA</b>			
	25 Zip II Cat DT	01 - 01	130 HF	2195
	50 AJP Caliper incl. pin/spring	91 - 19	188 HF	
	50 Dysis	02 - 05	105 HF	
	50 Fly	05 - 17	177 HF	2205
	50 Free (Disc Brake version)	93 - 96	130 HF	
	50 Free (Disc Brake version)	97 - 99	143 HF	2196
	50 HP	92 - 97	2146	2146
	50 Liberty	97 - 14	202 HF	2205
	50 Liberty 4T	00 - 12	202 HF	2205
	50 Liberty 4T	15 - 22	228 HF	
	50 New Liberty S	16 - 19	101 HF	
	50 Primavera	14 - 17	177 HF	
	50 Quartz	92 - 96	117 HF	2187
	50 Sfera	91 - 99		2187
	50 Sprint	15 - 17	177 HF	
	50 Storm	94 - 95	143 HF	2187
	50 Storm	96 - 97	130 HF	2187
	50 Typhoon	94 - 95	143 HF	2187
	50 Typhoon	96 - 05	130 HF	
	50 Typhoon	06 - 14	101 HF	
	50 Typhoon	18 - 22	237 HF	
	50 Typhoon Catalyzed	02 - 08	143 HF	143 HF
	50 V FL2	90 - 90	2146	2146
	50 Zip	92 - 93	2196	2187
	50 Zip & Zip	94 - 97	114 HF	2187
	50 Zip Disco	96 - 99	202 HF	2195
	50 Zip Fast Rider	93 - 95	143 HF	2200
	50 Zip Fast Rider	96 - 97	202 HF	2195
	50 Zip II	01 - 15	130 HF	2195
	50 Zip II Cat DT	01 - 12	130 HF	2195
	50 Zip RST	96 - 97	142 HF	
	50 Zip RST	98 - 99	202 HF	
	50 Zip Sport Production	96 - 99	202 HF	
ET2	50	97 - 06	202 HF	2195
ET4	50	00 - 05	202 HF	2195
LX	50 2T/4T	05 - 12	202 HF	2195
LXV	50	08 - 08	143 HF	
NRG	50	96 - 00	130 HF	2200
NRG	50 Extreme	01 - 01	143 HF	
NRG	50 mc2	97 - 99	143 HF	2200
NRG	50 mc3 DD	02 - 05	143 HF	143 HF
NRG	50 mc3 DT	02 - 05	143 HF	
NRG	50 Power DD	05 - 05	143 HF	143 HF
NRG	50 Power DD	06 - 16	101 HF	143 HF

\* = 2 sets required / 2 jeux pour l'Avant.

Full compound selection, see under "Brake pad 1:1 Drawings" / Sélection complète de composés, voir "1:1 Schémas Plaquettes de frein".

**RECOMMENDED**

1xx - 2xx = Scooter Pads  
5xx - 9xx = Street, Off Road & Racing Pads  
2xxx = Brake Shoes



PIAGGIO VESPA					
NRG	50 Purejet	05 - 05	143 HF	143 HF	
NRG	50 Purejet	06 - 07	101 HF	143 HF	
NRG.1	50	94 - 95	143 HF	2187	
NTT	50	96 - 96	130 HF	2200	
PK	50	83 - 98		2146	
PK	50 Special	83 - 98		2146	
PK	50 XL	86 - 98		2146	
PK	50 XL 2	86 - 98	2146	2146	
RST	50 Sfera	95 - 99	130 HF	2200	
S	50 2T	07 - 14	202 HF		
S	50 4T	09 - 14	202 HF		
S	50 College 4T	11 - 14	143 HF		
TPH	50	93 - 95	143 HF	2187	
TPH	50	96 - 97	130 HF	2200	
TPH	50 2T	11 - 17	177 HF		
	80 Sfera	94 - 99		2187	
	80 Skipper	93 - 95	117 HF		
	80 Skipper	96 - 94	130 HF		
	80 Typhoon	96 - 99	130 HF		
	100 Diesis	02 - 03	105 HF		
	100 Fly	07 - 15	177 HF	2205	
	100 Free 2T	02 - 02	143 HF		
	100 Free 4T	02 - 03	143 HF		
	100 Zip	07 - 10	177 HF	2205	
	125 946	14 - 16	177 CT	166 CT	
	125 Beverly	02 - 09	177 CT	177 CT	
	125 Carnaby	08 - 11	177 CT	177 CT	
	125 Cosa	89 - 91	2184	2185	
	125 Cosa 2	92 - 97	2184	2185	
	125 Fly	05 - 13	177 CT	2205	
	125 Hexagon	94 - 95	143 CT	2195	
	125 Liberty iGet 4T 3V	17 - 19	228 CT		
	125 Medley	16 - 19	228 CT	187 CT	
	125 Medley S	17 - 19	228 CT	187 CT	
	125 MP3	06 - 07	202 CT*	191 CT	
	125 MP3 (Parking Brake)	06 - 07		209 HF	
	125 MP3 Efi	08 - 11	202 CT*	187 CT	
	125 MP3 Efi (Parking Brake)	08 - 11		209 HF	
	125 MP3 Hybrid	09 - 12	202 CT*	187 CT	
	125 MP3 Hybrid (Parking Brake)	09 - 12		209 HF	
	125 MP3 Yourban	11 - 12	202 CT*	187 CT	
	125 MP3 Yourban (Parking Brake)	11 - 12		209 HF	
	125 New Liberty	16 - 19	228 CT		
	125 Primavera	14 - 16	177 CT		
	125 Primavera 70	16 - 16	177 CT		
	125 Sfera	95 - 01	202 CT	2195	
	125 Skipper	93 - 95	117 CT	2195	
	125 Skipper	96 - 98	130 CT		
	125 Sprint	16 - 17	177 CT		
	125 Sprint S	17 - 17	177 CT		
	125 Sprint Sport	17 - 17	177 CT		
	125 Typhoon	96 - 03	130 CT		
	125 Typhoon Catalyzed	02 - 11	143 CT	143 CT	
	125 X10 Executive Left	13 - 15	177 MS	187 MS	
	125 X10 Executive Right	13 - 15	187 MS		
	125 X7	08 - 12	177 CT	187 CT	
	125 X8	04 - 04	177 CT*	157 CT	
	125 X8	05 - 10	177 CT*	191 CT	
	125 X9	01 - 03	157 CT*	157 CT	
	125 X9 Left	04 - 11	177 CT	157 CT	
	125 X9 Right	04 - 11	187 CT		
	125 X9 Evolution Left	06 - 11	177 CT	157 CT	
	125 X9 Evolution Right	06 - 11	187 CT		
	125 Xevo	08 - 13	177 CT	187 CT	
	125 Zip II 4T	00 - 08	202 CT	2195	
ET4	125	96 - 10	202 CT	2195	
GT	125 L	04 - 09	177 CT	166 CT	
GTS	125	07 - 10	177 CT	166 CT	
GTS	125 Super	10 - 13	177 CT	166 CT	
GTS	125 Super i.e.	15 - 16	177 CT	166 CT	
GTS	125 Supersport	13 - 13	177 CT	166 CT	
GTS	125 Touring	18 - 19	177 CT	166 CT	

**RECOMMENDED**

1xx - 2xx = Scooter Pads  
5xx - 9xx = Street, Off Road & Racing Pads  
2xxx = Brake Shoes



PIAGGIO VESPA					
GTV	125	08 - 09	177 CT	166 CT	
GTX	125 SuperHexagon (Grimeca cal.)				
	(11" wheels)	00 - 00	120 CT	166 CT	
GTX	125 SuperHexagon (Hengtong cal.)				
	(11" wheels)	00 - 00	177 CT	166 CT	
GTX	125 SuperHexagon (Hengtong cal.)				
	(12" wheels)	01 - 03	177 CT	166 CT	
LE	125 Liberty	99 - 03	202 CT	2205	
LX	125 4T	05 - 13	202 CT		
LX	125 Hexagon	99 - 00	120 CT	2205	
LX	125 Skipper, ST	99 - 04	120 CT	2205	
LX4	125 Hexagon	99 - 07	120 CT	2195	
LXV	125	08 - 11	143 CT		
PK	125	83 - 89	2146	2146	
PK	125 Automatica	84 - 89	2146		
PK	125 Special	83 - 89	2146	2146	
PK	125 XL	86 - 89	2146	2146	
PX	125	78 - 89	2146	2146	
PX	125	02 - 11	117 CT		
PX	125 70	16 - 16	202 CT		
PX	125 Arcobalenco	83 - 89	2146	2146	
S	125 4T	07 - 10	202 CT		
SKR	125	94 - 03	143 CT		
TPH	125	96 - 03	130 CT	2195	
	150 Cosa	89 - 91	2184	2185	
	150 Fly	06 - 07	177 CT	2205	
	150 Hexagon	94 - 97	143 CT	2195	
	150 Liberty	99 - 03	202 CT	2205	
	150 Medley	16 - 19	228 CT	187 CT	
	150 Primavera	14 - 17	177 CT		
	150 Skipper	93 - 03	117 CT		
	150 Sprint Veloce	75 - 80		2146	
	150 X8 Street	06 - 08	177 CT		
ET4	150	02 - 06	202 CT		
LX	150	08 - 11	143 CT		
PX	150	78 - 82	2146	2146	
PX	150	02 - 06	202 CT		
PX	150 Arcobalenco	83 - 88	2146	2146	
GS	160	75 - 80		2146	
	180 X9	02 - 06	157 CT*	157 CT	
GTX	180 SuperHexagon (Grimeca cal.)				
	(11" wheels)	00 - 00	120 CT	166 CT	
GTX	180 SuperHexagon (Hengtong cal.)				
	(11" wheels)	00 - 00	177 CT	166 CT	
GTX	180 SuperHexagon (Hengtong cal.)				
	(12" wheels)	01 - 03	177 CT	166 CT	
LXT	180 Hexagon	99 - 00	120 CT	2205	
SS	180	75 - 80		2146	
	200 Beverly	02 - 03	177 CT	177 CT	
	200 Carnaby	08 - 12	177 CT	177 CT	
	200 Cosa	89 - 91	2184	2185	
	200 Cosa 2	92 - 97	2184	2185	
	200 Liberty	06 - 13	202 CT		
	200 Rally	75 - 80		2146	
	200 X8	04 - 04	177 CT*	157 CT	
	200 X8	05 - 05	177 CT*	191 CT	
	200 X9	03 - 11	157 CT*	157 CT	
BV	200	02 - 04	177 CT	177 CT	
BV	200	05 - 05	177 CT	168 CT	
GT	200 L	04 - 09	177 CT	166 CT	
PE	200	83 - 88	2146	2146	
PX	200	02 - 07	202 CT		
PX	200 Arcobalenco	83 - 85	2146	2146	
PX	200 E	78 - 85	2146	2146	
	250 Beverly	07 - 08	177 MS	177 MS	
	250 GT 60	06 - 07	177 MS	166 MS	
	250 LX 60	06 - 10	202 MS		
	250 MP3	06 - 07	202 MS*	191 MS	
	250 MP3 (Parking Brake)	06 - 07		209 HF	
	250 MP3 Efi	08 - 09	202 MS*	187 MS	
	250 MP3 Efi (Parking Brake)	08 - 09		209 HF	
	250 MP3 LT IE	09 - 09	202 MS*	187 MS	

\* = 2 sets required / 2 jeux pour l'Avant.

Full compound selection, see under "Brake pad 1:1 Drawings" / Sélection complète de composants, voir "1:1 Schémas Plaquettes de frein".



**RECOMMENDED**

1xx - 2xx = Scooter Pads  
5xx - 9xx = Street, Off Road & Racing Pads  
2xxx = Brake Shoes



**PIAGGIO VESPA**

	250 MP3 LT iE (Parking Brake)	09 - 09		209 HF
	250 X7	08 - 09	177 MS	187 MS
	250 X8	06 - 09	177 MS*	191 MS
	250 X9	00 - 04	157 MS*	157 MS
	250 X9 Left	05 - 10	177 MS	191 MS
	250 X9 Right	05 - 10	187 MS	
	250 Xevo	08 - 11	177 MS	187 MS
BV	250	06 - 06	177 MS	177 MS
GT	250 Hexagon	99 - 03	120 MS	
GTS	250	06 - 07	177 MS	166 MS
GTV	250	08 - 10	177 MS	166 MS
GTX	250 Super Hexagon	01 - 02	120 MS	166 MS
	300 Beverly hpe	22 - 22	177 MS	134 MS
	300 Beverly i.e.	11 - 19	177 MS	187 MS
	300 Beverly Tourer	07 - 08	177 MS	177 MS
	300 Carnaby Cruiser	10 - 13	177 MS	177 MS
	300 MP3 Hybrid	11 - 12	202 MS*	187 MS
	300 MP3 Hybrid (Parking Brake)	11 - 12		209 HF
	300 MP3 Hybrid iE	11 - 19	202 MS*	187 MS
	300 MP3 Hybrid iE (Parking Brake)	11 - 19		209 HF
	300 MP3 iE	10 - 19	202 MS*	187 MS
	300 MP3 iE (Parking Brake)	10 - 19		209 HF
	300 MP3 LT	13 - 19	202 MS*	187 MS
	300 MP3 LT (Parking Brake)	13 - 19		209 HF
	300 MP3 LT Business	13 - 19	202 MS*	187 MS
	300 MP3 LT Business (Parking Brake)	13 - 19		209 HF
	300 MP3 LT iE ABS	14 - 19	224 MS*	187 MS
	300 MP3 LT iE ABS (Parking Brake)	14 - 19		209 HF
	300 MP3 LT Sport ABS	14 - 19	224 MS*	187 MS
	300 MP3 LT Sport ABS (Parking Brake)	14 - 19		209 HF
	300 MP3 LT Touring	11 - 12	202 MS*	187 MS
	300 MP3 LT Touring (Parking Brake)	11 - 12		209 HF
	300 MP3 Touring	11 - 12	202 MS*	187 MS
	300 MP3 Touring (Parking Brake)	11 - 12		209 HF
	300 MP3 Yourban iE	11 - 19	202 MS*	187 MS
	300 MP3 Yourban iE (Parking Brake)	11 - 19		209 HF
	300 Sei Giorni	18 - 19	177 MS	166 MS
	300 X7 Evo i.e.	11 - 13	177 MS	187 MS
GTS	300 i.e.	12 - 15	177 MS	166 MS
GTS	300 Super	09 - 12	177 MS	166 MS
GTS	300 Super Notte	19 - 20	177 MS	166 MS
GTS	300 Super Sport i.e.	11 - 15	177 MS	166 MS
GTS	300 Touring ABS	17 - 17	177 MS	166 MS
GTS	300 Touring i.e.	11 - 12	177 MS	166 MS
GTS	300 Yacht Club	18 - 18	177 MS	166 MS
GTV	300 i.e.	11 - 15	177 MS	166 MS
	350 Beverly S	14 - 19	177 MS	187 MS
	350 Beverly Sport Touring ie	12 - 19	159 MS	187 MS
	350 Beverly Sport Touring ie ABS	12 - 19	177 MS	187 MS
	350 X10 Executive Left	13 - 16	177 MS	187 MS
	350 X10 Executive Right	13 - 16	187 MS	
	350 X10 Executive (Parking Brake)	13 - 16		209 HF
BV	350	12 - 17	177 MS	187 MS
	400 Beverly hpe S	22 - 22	177 MS	187 MS
	400 MP3 iE	07 - 10	202 MS*	177 MS
	400 MP3 iE (Parking Brake)	07 - 10		209 HF
	400 MP3 LT iE	09 - 10	202 MS*	177 MS
	400 MP3 LT iE (Parking Brake)	09 - 10		209 HF
	400 MP3 LT Touring	11 - 12	202 MS*	177 MS
	400 MP3 LT Touring (Parking Brake)	11 - 12		209 HF
	400 MP3 Touring	11 - 12	202 MS*	177 MS
	400 MP3 Touring (Parking Brake)	11 - 12		209 HF
	400 X8 Left	07 - 08	177 MS	177 MS
	400 X8 Right	07 - 08	187 MS	
	400 Xevo Left	08 - 11	177 MS	177 MS
	400 Xevo Right	08 - 11	187 MS	
	500 Beverly Cruiser	08 - 12	157 MS*	157 MS
	500 MP3	10 - 10	202 MS*	177 MS
	500 MP3 (Parking Brake)	10 - 10		209 HF
	500 MP3 LT Touring Business	11 - 13	202 MS*	177 MS



**RECOMMENDED**

1xx - 2xx = Scooter Pads  
5xx - 9xx = Street, Off Road & Racing Pads  
2xxx = Brake Shoes



**PIAGGIO VESPA**

	500 MP3 LT Touring Business (Parking Brake)	11 - 13		209 HF
	500 MP3 LT Touring Business ABS	14 - 15	224 MS*	177 MS
	500 MP3 LT Touring Business ABS (Parking Brake)	14 - 15		209 HF
	500 MP3 LT Touring Sport	11 - 13	202 MS*	177 MS
	500 MP3 LT Touring Sport (Parking Brake)	11 - 13		209 HF
	500 MP3 LT Touring Sport ABS	14 - 15	224 MS*	177 MS
	500 MP3 LT Touring Sport ABS (Parking Brake)	14 - 15		209 HF
	500 MP3 Touring Business	11 - 12	202 MS*	177 MS
	500 MP3 Touring Business (Parking Brake)	11 - 12		209 HF
	500 MP3 Touring Sport	11 - 12	202 MS*	177 MS
	500 MP3 Touring Sport (Parking Brake)	11 - 12		209 HF
	500 X10 Executive Left	13 - 15	177 MS	187 MS
	500 X10 Executive Right	13 - 15	187 MS	
	500 X10 Executive (Parking Brake)	13 - 15		209 HF
	500 X9	01 - 03	157 MS*	157 MS
	500 X9 Evolution	04 - 07	151 MS*	157 MS
	500 X9 Evolution ABS	04 - 07	151 MS	157 MS
BV	500	06 - 08	157 MS*	157 MS

**POLARIS**

	EV-LSV	10 - 11	897 ATS*	800 ATS
	LSV 4x4	11 - 12	897 ATS*	800 ATS
	Ranger 48v EV	13 - 18	897 ATS*	800 ATS
	50 Predator	04 - 14	2048*	
	50 Scrambler	01 - 03	2048*	
	90 Predator	03 - 14	2043*	
	90 Scrambler	01 - 03	2048*	
	90 Sportsman	01 - 15	2048*	
	170 Ranger RZR	09 - 16	905 SI*	906 SI
	170 Ranger RZR	17 - 21	905 SI*	546 SI
	200 Phoenix	05 - 09	544 ATS*	546 SI
	200 Phoenix	10 - 14	905 SI*	546 SI
	200 Sawtooth	06 - 07	544 ATS*	544 ATS
	250 2x4, 4x4	90 - 93	716 ATS*	717 ATS
	250 Big Boss 4x6, 6x6	89 - 93	716 ATS*	717 ATS
	250 Big Boss 4x6, 6x6 Middle Axle Brake	89 - 93	717 ATS	
	250 Cyclone	87 - 87	2028*	643 HF
	250 Trail Blazer	90 - 98	716 ATS*	717 ATS
	250 Trail Blazer	99 - 07	716 ATS*	755 ATS
	250 Trail Boss	88 - 90	642 ATS*	643 HF
	250 Trail Boss	91 - 99	716 ATS*	717 ATS
	250 Trail Boss 2x4, 4x4	91 - 92	716 ATS*	717 ATS
	250 Xplorer 4x4	00 - 02	716 ATS*	755 ATS
	300 2x4, 4x4	94 - 95	716 ATS*	717 ATS
	300 Big Boss 6x6	94 - 94	716 ATS*	717 ATS
	300 Big Boss 6x6 Middle Axle Brake	94 - 94	717 ATS	
	300 Hawkeye 2x4, 4x4	06 - 06	822 ATS*	822 ATS
	300 Hawkeye 2x4, 4x4	07 - 11	716 ATS*	716 ATS
	300 Sportsman 4x4	08 - 11	642 ATS*	642 ATS
	300 Xplorer 4x4	96 - 99	716 ATS*	717 ATS
	300 Xpress 2x4	98 - 99	716 ATS*	717 ATS
	300 Xpress L	96 - 97	716 ATS*	717 ATS
	325 Magnum 2x4, 4x4	00 - 02	716 ATS*	755 ATS
	325 Trail Boss	00 - 02	716 ATS*	755 ATS
	325 Xpedition	00 - 01	642 ATS*	755 ATS
	325 Xpedition	02 - 02	642 ATS*	787 ATS
	330 ATP	04 - 05	716 ATS*	716 ATS*
	330 ATP	06 - 05	716 ATS*	787 ATS*
	330 E Trail Blazer	08 - 12	642 ATS*	787 ATS
	330 Magnum 2x4, 4x4	03 - 13	716 ATS*	787 ATS
	330 Trail Boss	03 - 14	716 ATS*	755 ATS
	335 Sportsman 4x4	99 - 02	716 ATS*	755 ATS
	350 Big Boss	93 - 93	716 ATS*	717 ATS
	350 Big Boss Middle Axle Brake	93 - 93	717 ATS	

\* = 2 sets required / 2 jeux pour l'Avant.

Full compound selection, see under "Brake pad 1:1 Drawings" / Sélection complète de composés, voir "1:1 Schémas Plaquettes de frein".



**RECOMMENDED**1xx - 2xx = Scooter Pads  
5xx - 9xx = Street, Off Road & Racing Pads  
2xxx = Brake Shoes

POLARIS				
350 L 2x4, 4x4	90 - 90	716 ATS*	717 ATS	
350 L 4x4	93 - 93	716 ATS*	717 ATS	
350 Sportsman 4x4	93 - 93	716 ATS*	717 ATS	
350 Trail Boss 2x4	85 - 87	2028*		
350 Trail Boss 2x4, 4x4	88 - 89	716 ATS*	717 ATS	
350 Trail Boss L 2x4	91 - 93	716 ATS*	717 ATS	
350 Trail Boss L 4x4	91 - 91	716 ATS*	717 ATS	
400 Big Boss L 6x6	96 - 96	716 ATS*	717 ATS	
400 Big Boss L 6x6				
Middle Axle Brake	96 - 96	756 ATS		
400 L 2x4	94 - 95	716 ATS*	717 ATS	
400 L 4x4	94 - 94	716 ATS*	717 ATS	
400 Scrambler 2x4, 4x4	00 - 03	716 ATS*	755 ATS	
400 Scrambler 4x4	98 - 98	716 ATS*	717 ATS	
400 Scrambler 4x4	99 - 03	716 ATS*	755 ATS	
400 Scrambler L 4x4	95 - 97	716 ATS*	717 ATS	
400 Sport	99 - 00	716 ATS*	755 ATS	
400 Sport L	94 - 98	716 ATS*	717 ATS	
400 Sportsman	01 - 13	716 ATS*	755 ATS	
400 Sportsman L 4x4	94 - 97	716 ATS*	717 ATS	
400 Trail Blazer	03 - 04	716 ATS*	755 ATS	
400 Xplorer L 4x4	95 - 99	716 ATS*	717 ATS	
400 Xplorer L 4x4	00 - 02	716 ATS*	755 ATS	
400 Xpress L	96 - 97	716 ATS*	717 ATS	
425 2x4, 4x4 Magnum	95 - 98	716 ATS*	717 ATS	
425 Magnum 6x6	96 - 96	716 ATS*	717 ATS	
425 Magnum 6x6				
Middle Axle Brake	96 - 96	756 ATS		
425 Xpedition 4x4	00 - 03	716 ATS*	755 ATS	
450 Outlaw MXR	09 - 11	898 ATS*	642 ATS	
450 Outlaw S	08 - 08	898 ATS*	642 ATS	
450 Sportsman	06 - 09	716 ATS*	787 ATS	
455 Diesel EBS 4x4	99 - 01	716 ATS*	755 ATS	
500 ATP HO	04 - 05	716 ATS*	716 ATS*	
500 Big Boss 6x6	98 - 99	716 ATS*	717 ATS	
500 Big Boss 6x6				
Middle Axle Brake	98 - 99	717 ATS		
500 E Scrambler 2x4, 4x4	08 - 11	642 ATS*	787 ATS	
500 Magnum 2x4, 4x4	02 - 07	716 ATS*	787 ATS	
500 Magnum 4x4	00 - 01	716 ATS*	755 ATS	
500 Outlaw	06 - 09	716 ATS*	716 ATS	
500 Predator	03 - 13	716 ATS*	716 ATS	
500 Predator e	06 - 13	716 ATS*	787 ATS	
500 Ranger 2x4	08 - 07	897 ATS*	800 ATS	
500 Ranger 2x4 EFI	08 - 13	897 ATS*	800 ATS	
500 Ranger 2x4, 4x4, 6x6	02 - 13	800 ATS*	800 ATS*	
500 Ranger 4x4	12 - 13	897 ATS*	800 ATS	
500 Ranger 6x6	00 - 02	716 ATS*		
500 Ranger XP	06 - 09	800 ATS*	800 ATS	
500 Revolver	06 - 06	642 ATS*	642 ATS	
500 Scrambler 2x4	01 - 02	716 ATS*	755 ATS	
500 Scrambler 4x4	97 - 97	716 ATS*	717 ATS	
500 Scrambler 4x4	98 - 13	716 ATS*	787 ATS	
500 Sportsman 4x4	96 - 14	716 ATS*	717 ATS	
500 Sportsman 6x6	00 - 11	716 ATS*	757 ATS	
500 Sportsman EBS 4x4	98 - 02	716 ATS*	755 ATS	
500 Sportsman HO (from 16.12.2008)	09 - 14	642 ATS*	899 ATS	
500 Sportsman HO (to 15.12.2008)	03 - 08	642 ATS*	787 ATS	
500 Xplorer 4x4	97 - 97	716 ATS*	717 ATS	
525 Outlaw	07 - 13	898 ATS*	642 ATS	
525 Outlaw IRS	08 - 13	898 ATS*	642 ATS	
525 Outlaw S	08 - 11	898 ATS*	642 ATS	
550 Sportsman	11 - 14	899 ATS*	899 ATS	
550 Sportsman EPS	10 - 14	899 ATS*	899 ATS	
550 Sportsman EPS X2	14 - 14	899 ATS*	899 ATS	
550 Sportsman Touring EPS	10 - 12	899 ATS*	899 ATS	
550 Sportsman X2	10 - 14	899 ATS*	899 ATS	
550 Sportsman XP	09 - 12	899 ATS*	899 ATS	
550 Sportsman XP EPS	09 - 14	899 ATS*	899 ATS	
550 Sportsman XP Touring EPS	12 - 14	899 ATS*	899 ATS	

**RECOMMENDED**1xx - 2xx = Scooter Pads  
5xx - 9xx = Street, Off Road & Racing Pads  
2xxx = Brake Shoes

POLARIS				
570 RZR EFI	12 - 19	898 PSI*	642 PSI	
570 RZR Trail	20 - 22	898 PSI*	642 PSI*	
600 Sportsman	03 - 06	642 ATS*	787 ATS*	
700 MVRs 4x4	08 - 08	897 ATS*	897 ATS	
700 Ranger 4x4 EFI	08 - 08	897 ATS*	800 ATS	
700 Ranger 6x6 EFI	12 - 13	897 ATS*	800 ATS	
700 Sportsman	02 - 09	642 ATS*	787 ATS*	
700 Sportsman MV 700	05 - 06	642 ATS*	787 ATS	
800 MVRs 4x4	08 - 08	897 ATS*	897 ATS	
800 Ranger 4x4 EFI	10 - 10	897 ATS*	897 ATS	
800 Ranger 6x6 EFI	12 - 15	897 ATS*	897 ATS	
800 Ranger Crew	12 - 15	897 ATS*	897 ATS	
800 Ranger RZR EFI	08 - 14	898 ATS*	642 ATS	
800 Ranger RZR S EFI	09 - 15	898 ATS*	642 ATS	
800 Ranger RZR4 EFI	12 - 14	897 ATS*	800 ATS	
800 Ranger XP	12 - 13	897 ATS*	800 ATS	
800 RZR	08 - 15	898 ATS*	642 ATS	
800 RZR-4	10 - 14	897 ATS*	800 ATS	
800 Sportsman (from 16.12.2008)	09 - 14	642 ATS*	899 ATS	
800 Sportsman (to 15.12.2008)	05 - 08	642 ATS*	787 ATS	
850 Forest	15 - 15	899 ATS*	899 ATS	
850 Scrambler	15 - 15	899 ATS*	899 ATS	
850 Scrambler HO EPS	13 - 15	899 ATS*	899 ATS	
850 Scrambler MD	15 - 15	899 ATS*	899 ATS	
850 Scrambler XP HO EPS	14 - 15	899 ATS*	899 ATS	
850 Sportsman	11 - 13	899 ATS*	899 ATS	
850 Sportsman MV	12 - 12	899 ATS*	899 ATS	
850 Sportsman Touring	14 - 15	899 ATS*	899 ATS	
850 Sportsman Touring EPS	10 - 13	899 ATS*	899 ATS	
850 Sportsman Touring HO EPS	13 - 14	899 ATS*	899 ATS	
850 Sportsman Touring MD	15 - 15	899 ATS*	899 ATS	
850 Sportsman X2	11 - 11	899 ATS*	899 ATS	
850 Sportsman XP	09 - 14	899 ATS*	899 ATS	
850 Sportsman XP EPS	09 - 14	899 ATS*	899 ATS	
850 Sportsman XP HO EPS	13 - 14	899 ATS*	899 ATS	
850 Sportsman XP HO EPS MD	15 - 15	899 ATS*	899 ATS	
850 Sportsman XP Touring EPS	15 - 15	899 ATS*	899 ATS	
900 Ranger 4x4 Diesel	10 - 14	897 ATS*	897 ATS	
900 Ranger RZR4 XP EFI	12 - 15	897 ATS*	897 ATS	
900 Ranger RZR4 XP4 EFI	12 - 14	897 ATS*	897 ATS	
900 RZR Trail	20 - 20	970 PSI*	898 PSI*	
900 RZR Trail S	20 - 22	970 PSI*	898 PSI*	
900 RZR-S	15 - 20	970 PSI*	898 PSI	
RZR 900 50/55/60 Inch	15 - 20	970 PSI*	898 PSI	
925 RZR Pro R	22 - 23	977 SI*	978 SI*	
925 RZR Pro R4	22 - 23	977 SI*	978 SI*	
925 RZR Pro XP	20 - 23	954 SI*	978 SI*	
925 RZR Pro XP4	20 - 23	954 SI*	978 SI*	
925 RZR RS1	18 - 22	897 PSI*	897 PSI*	
925 RZR Turbo R	22 - 23	977 SI*	978 SI*	
925 RZR Turbo R4	22 - 23	977 SI*	978 SI*	
925 RZR Turbo XP4 Turbo S	19 - 20	977 SI*	897 SI*	
925 RZR XP Turbo	16 - 19	954 SI*	897 SI	
925 RZR XP Turbo	20 - 21	954 SI*	978 SI*	
925 RZR XP4 Turbo	16 - 19	954 SI*	897 SI	
925 RZR XP4 Turbo	20 - 21	954 SI*	978 SI*	
925 RZR XP4 Turbo S	19 - 20	977 SI*	897 SI*	
925 RZR XP4 Turbo S Velocity	19 - 20	977 SI*	897 SI*	
1000 Forest	15 - 15	899 ATS*	899 ATS	
1000 General EPS	16 - 18	897 ATS*	898 ATS	
1000 RZR Trail S	20 - 23	970 PSI*	898 PSI*	
1000 RZR XP	14 - 23	897 PSI*	897 PSI	
1000 RZR XP4	14 - 23	897 PSI*	897 PSI*	
1000 RZR-S	16 - 20	970 PSI*	898 PSI	
1000 Scrambler MD	15 - 18	899 ATS*	899 ATS	
1000 Scrambler XP	15 - 18	899 ATS*	899 ATS	
1000 Scrambler XP HO EPS	14 - 14	899 ATS*	899 ATS	
1000 Sportsman MD	15 - 18	899 ATS*	899 ATS	
1000 Sportsman Touring	15 - 18	899 ATS*	899 ATS	
1000 Sportsman XP	15 - 18	899 ATS*	899 ATS	
RZR 1000 60 Inch	16 - 20	970 PSI*	898 PSI	
1050 MV Diesel Crew	13 - 18	897 ATS*	897 ATS	

\* = 2 sets required / 2 jeux pour l'Avant.

Full compound selection, see under "Brake pad 1:1 Drawings" / Sélection complète de composés, voir "1:1 Schémas Plaquettes de frein".



**RECOMMENDED**

1xx - 2xx = Scooter Pads  
5xx - 9xx = Street, Off Road & Racing Pads  
2xxx = Brake Shoes



<b>POLINI</b>				
X1	50 R	04 - 06	794 RSI	794 RSI
X3	50 R	04 - 06	794 RSI	794 RSI
X5	65 RP	05 - 06	794 RSI	794 RSI
<b>PRAGA</b>				
ED	250	99 - 03	671 SI	675 SI
CD	610	99 - 03	671 SI	675 SI
<b>PROTOS</b>				
	50 Ellisse Scooter car	98 - 98	123 HF	
<b>PUCH</b>				
	50 all models	86 - 86	532 HF	
	50 Cobra 6 GT, GTL	80 - 84	532 HF	2074
	50 Condor	90 - 90	559 HF	
	50 Maxi 30 all models (excl. Spain)	69 - 80	2074	2074
	50 Maxi 40 all models	69 - 80	2074	2074
	50 Monza 4 GP, all models	79 - 83	2074	2074
	50 Monza 4 SL	79 - 79	2074	2074
	50 Monza 4 SL, GSL	80 - 83	532 HF	2074
	50 Storm (Austria)	78 - 83	143 HF	2187
	50 Typhoon (Austria)	95 - 95	143 HF	2187
	50 Typhoon (Austria)	96 - 96	130 HF	2200
AP	50	71 - 80	2015	2015
TZX	50	92 - 92	559 HF	
	75 Cobra	85 - 85	559 HF	
MAXI	80	88 - 88	133 HF	138 HF
	125 Typhoon (Austria)	82 - 82	130 CT	
<b>QJ MOTOR</b>				
SRT	550 X	23 - 23	900 HS*	730 LS
SRK	600	23 - 23	900 HS*	730 LS
SRK	600	24 - 24	762 HS*	730 LS
SRK	600 RR	23 - 23	900 HS*	730 LS
SVT	650	23 - 23	900 HS*	730 LS
SVT	650 X	24 - 24	900 HS*	730 LS
SRT	700 Standard E X	23 - 23	900 HS*	730 LS
SRK	800 RR	24 - 24	900 HS*	730 LS
SRT	800 Standard E X	23 - 23	900 HS*	730 LS
SRK	900 RR	24 - 24	841 HS*	730 LS
<b>QUADRO</b>				
	350 3	16 - 16	145 MS*	101 MS
	350 4	16 - 16	145 MS*	101 MS*
D	350	11 - 15	123 CT*	101 CT
<b>QUADZILLA</b>				
WK	140	06 - 08	211 HF	213 HF
XRV	250 , E	06 - 07	855 HF*	848 HF
<b>QUINGOI</b>				
QM	125 2V	02 - 05	691 HF	
QM	125 GY	02 - 05	713 HF	
<b>RBS CARS</b>				
	900 Adventure	15 - 16	944 HS*	
<b>REAL</b>				
	80 Nevada Sport	00 - 00	532 HF	
<b>REWACO</b>				
	FX4	07 - 07	519 HF	
	FX5	07 - 07	519 HF	
	FX6	07 - 07	519 HF	
	HS4	01 - 01	519 HF	
	HS5	01 - 01	519 HF	
	HS6	01 - 01	519 HF	
	RF1	07 - 14	519 HF	
<b>RIEJU</b>				
	50 AJP Caliper incl. pin/spring	91 - 19	188 HF	



**RECOMMENDED**

1xx - 2xx = Scooter Pads  
5xx - 9xx = Street, Off Road & Racing Pads  
2xxx = Brake Shoes



<b>RIEJU</b>				
	50 Drac	97 - 97	559 HF	559 HF
	50 Drag	92 - 92	595 HF	
	50 FD4 Super Marathon	85 - 85	559 HF	
	50 First, H2O	97 - 99	105 HF	
	50 Racing Spec. Edition	01 - 01	148 HF	105 HF
	50 Spike Racing	02 - 06	105 HF	105 HF
	50 Spike Racing	02 - 06	148 HF	105 HF
	50 Spike X	08 - 09	585 HF	585 HF
	50 Tango	08 - 12	157 HF	105 HF
	50 Tangoo	10 - 12	730 HF	559 HF
	50 Windy	97 - 97	105 HF	
MRT	50	09 - 15	203 HF	203 HF
MRT	50 Pro	09 - 14	157 HF	157 HF
MRT	50 Pro Supermotard	09 - 17	157 HF	157 HF
MRT	50 Supermotard	09 - 17	203 HF	203 HF
MRX	50 , Racing	02 - 09	105 HF	105 HF
MRX	50 Pro	05 - 09	148 HF	105 HF
NKD	50	04 - 07	173 HF	105 HF
RR	50 , Supermotard	96 - 05	559 HF	559 HF
RRX	50	08 - 08	105 HF	105 HF
RRX	50	08 - 08	203 HF	203 HF
RRX	50 Spike	08 - 08	105 HF	105 HF
RS1	50	92 - 05	595 HF	559 HF
RS1	50 , Castrol	01 - 03	120 HF	105 HF
RS1	50 Evolution	96 - 00	105 HF	105 HF
RS2	50 Matrix	03 - 09	173 HF	167 HF
RS2	50 NKD	06 - 10	180 HF	101 HF
RS3	50	12 - 17	173 HF	101 HF
RS3	50 Pro	12 - 17	189 MS	105 HF
RV	50	80 - 80	559 HF	
SMX	50	02 - 09	105 HF	105 HF
SMX	50	02 - 09	148 HF	105 HF
SMX	50 Pro	08 - 09	157 HF	105 HF
	75 K6, LC Strada	87 - 87	559 HF	
	75 P6, LC Strada	87 - 87	559 HF	
MR	80 C, E	88 - 90	559 HF	
MR	80 Cross	87 - 87	559 HF	
MR	80 Enduro	87 - 87	559 HF	
RST	80	91 - 93	559 HF	559 HF
	125 Marathon Pro	09 - 14	730 HF	585 HF
	125 Marathon Pro Supermotard	09 - 15	730 HF	585 HF
	125 Tango	06 - 07	821 HS	559 HF
	125 Tango	08 - 12	730 HF	559 HF
	125 Tango Pro	08 - 08	730 HF	559 HF
MRX	125	03 - 08	559 HF	559 HF
MRX	125	03 - 08	652 HF	559 HF
RR	125	97 - 99	559 HF	559 HF
RS2	125 NKD	06 - 07	797 HF	544 HF
RS2	125 Pro	08 - 12	792 HF	544 HF
RS3	125	10 - 13	821 HS	559 HF
SMX	125	03 - 07	559 HF	559 HF
SMX	125	03 - 07	652 HF	559 HF
	250 Tango	08 - 15	730 HF	559 HF
MRX	250 Marathon	10 - 12	671 SI	791 SI
MRX	450 Marathon	08 - 12	671 SI	791 SI
<b>RIXE</b>				
RS	80 W	82 - 82	532 HF	
<b>ROXON</b>				
	50 Duel SM	06 - 06	105 HF	105 HF
	50 Duel TT	06 - 06	105 HF	105 HF
	150 Quad Sport Spirit	06 - 06		544 SI
<b>ROYAL ENFIELD</b>				
	350 Classic	23 - 23	671 HS	675 LS
	350 Meteor	23 - 23	671 HS	675 LS
	411 Himalayan	19 - 23	671 HF	675 HF
	451 Himalayan	24 - 24	674 HS	675 LS
	500 Bullet	20 - 20	671 HS	675 LS
	500 Bullet Trials	20 - 20	671 HS	675 LS
	500 Classic	19 - 19	671 HF	675 HF

\* = 2 sets required / 2 jeux pour l'Avant.

Full compound selection, see under "Brake pad 1:1 Drawings" / Sélection complète de composés, voir "1:1 Schémas Plaquettes de frein".

**RECOMMENDED**1xx - 2xx = Scooter Pads  
5xx - 9xx = Street, Off Road & Racing Pads  
2xxx = Brake Shoes

ROYAL ENFIELD				
	535 Continental GT	14 - 19	674 HS	675 LS
	650 Continental GT	20 - 23	674 HS	675 LS
	650 Interceptor	19 - 23	674 HS	675 LS
	650 Super Meteor	23 - 23	674 HS	671 LS
SACHS				
	50 MadAss	04 - 05	200 HF	
	50 MadAss 4T	05 - 09	200 HF	100 HF
SA	80 Lotus	80 - 81	532 HF	
SW	80 Lotus	82 - 82	519 HF*	
	125 MadAss	09 - 09	200 HF	100 HF
	125 Roadster V2	01 - 01	588 HF	
	125 X-Road	05 - 07	566 HF	684 HF
XTC	125	99 - 07	566 HF	684 HF
XTC-N	125	99 - 07	566 HF	684 HF
ZX	125	99 - 02	588 HF	684 HF
ZZ	125	99 - 02	588 HF	684 HF
	500 MadAss	05 - 08	566 HF*	684 HF
	650 Roadster V1.6	01 - 05	566 HF	684 HF
	800 B-805	02 - 04	566 HS*	
	800 Roadster V2	00 - 05	566 HF*	684 HF
	800 S-805	03 - 04	566 HS*	
SANGLAS				
	400 Y	79 - 80	519 HF*	519 HF
	500 S2	79 - 80	519 HF*	519 HF
SCORPA				
SY	115 F Trial	06 - 06	802 RSI	803 RSI
TY-S	115 F Trial	06 - 06	559 HF	803 RSI
	125 Twenty Trial	16 - 18	802 RSI	803 RSI
SY	125 F Trial	06 - 11	802 RSI	803 RSI
TY-S	125 F Trial	06 - 08	559 HF	803 RSI
	250 T-Ride	08 - 11	859 HF	773 HF
	250 Twenty Trial	16 - 18	802 RSI	803 RSI
SY	250 F Trial	06 - 11	802 RSI	803 RSI
SY	250 Trial	00 - 01	802 RSI	803 RSI
	300 Twenty Trial	16 - 18	802 RSI	803 RSI
SHE-LUNG				
	50 Falcon	97 - 97	111 HF	
	50 Racer	96 - 96	114 HF	
	125 Mars	97 - 97	111 CT	
SHERCO				
	50 AJP Caliper incl. pin/spring	91 - 19	188 HF	
	50 Supermotard, Enduro	02 - 06	148 HF	105 HF
SE	50 Enduro	07 - 07	168 HF	167 HF
SM	50 Supermotard	07 - 13	168 HF	167 HF
	80 0.8	01 - 03	559 HF	559 HF
ST	80 (Formula cal.)	13 - 14	885 RSI	803 RSI
	125	02 - 02	817 HF	559 HF
	125 City Corp 4T Enduro	03 - 07	817 HF	559 HF
	125 City Corp 4T SM	03 - 07	817 HF	559 HF
SE	125 1.25F	10 - 12	774 HF	773 HF
SE-R	125	17 - 19	671 SI	791 SI
ST	125 (Formula cal.)	13 - 14	885 RSI	803 RSI
ST	125 1.25	01 - 05	559 HF	559 HF
ST	125 1.25	06 - 11	802 RSI	803 RSI
ST	200 2.0	01 - 01	559 HF	559 HF
SE	250 , R	14 - 14	671 SI	791 SI
SE	250 2.5i Enduro	06 - 11	671 SI	790 SI
SE	250 F, F-R	14 - 19	671 SI	791 SI
SE	250 i/R	12 - 13	671 SI	791 SI
SE	250 i-F	13 - 13	671 SI	791 SI
ST	250	99 - 00	559 RSI	559 RSI
ST	250 (Formula cal.)	13 - 14	885 RSI	803 RSI
ST	250 2.5	01 - 01	802 RSI	803 RSI
SX	250 2.5i-F	09 - 11	671 RSI	790 RSI
ST	290 (Formula cal.)	13 - 14	885 RSI	803 RSI
ST	290 2.9	01 - 01	802 RSI	803 RSI
SCF-R	300	16 - 19	671 SI	791 SI

**RECOMMENDED**1xx - 2xx = Scooter Pads  
5xx - 9xx = Street, Off Road & Racing Pads  
2xxx = Brake Shoes

SHERCO				
SE	300 , R	14 - 19	671 SI	791 SI
SE	300 3.0i-F	10 - 11	671 SI	790 SI
SE	300 F, F-R	14 - 19	671 SI	791 SI
SE	300 i/R	12 - 13	671 SI	791 SI
SE	300 i-F	13 - 13	671 SI	791 SI
ST	300	16 - 19	802 RSI	803 RSI
ST	305 (Formula cal.)	13 - 14	885 RSI	803 RSI
ST	320 3.2F	05 - 05	802 RSI	803 RSI
SE	450 4.5i Enduro	04 - 04	671 SI	604 SI
SE	450 4.5i Enduro	05 - 11	671 SI	790 SI
SE	450 F, F-R	14 - 19	671 SI	791 SI
SE	450 iR	12 - 13	671 SI	791 SI
SM	450 4.5i Supermotard	06 - 06	762 RST	790 RSI
SE	510 5.1i Enduro	06 - 11	671 SI	790 SI
SE	510 iR	12 - 13	671 SI	791 SI
SIAM				
	50 Falcon	97 - 97	123 HF	
	50 Mat	97 - 97	102 HF	
	50 Scross	97 - 97	123 HF	
	100 Mat	97 - 97	102 HF	
SIAMOTO				
	50 Birdie	02 - 04	111 HF	
	125 BD, KD	02 - 04	148 CT	
SIMSON				
	50 Habict CX	01 - 99	519 HF	
	50 Spatz	99 - 99	138 HF	
	50 Sperber	99 - 99	138 HF	
	50 Star	99 - 99	138 HF	
	80 IFA	89 - 89	519 HF	
SR	80 -2 CE	87 - 87	519 HF	
S	83 CX	93 - 93	519 HF	
S	83 OR	83 - 83	519 HF	
	125	01 - 01	588 HF	684 HF
	125 RS	01 - 01	588 HF	684 HF
	125 Schikra	99 - 99	108 CT	138 CT
	125 SM	01 - 01	652 HF	559 HF
	125 Star	99 - 99	105 CT	
SMC				
	50 Easy Rider	97 - 97	102 HF	2028
STARK				
	Varg	23 - 24	671 RSI	791 RSI
STOMP				
	125 Elite	07 - 09	211 HF	213 HF
SULA				
	50 City Bird	99 - 99	111 HF	2028
	50 Thunder Bird	99 - 99	101 HF*	2028
	100 Thunder Bird	99 - 99	101 HF*	2028
	125 Thunder Bird	99 - 99	101 CT	2028
SUZUKI				
RE	5M, A	75 - 77	503 HF	2098
	50 AJP Caliper incl. pin/spring	91 - 19	188 HF	
	50 Lido Scooter	89 - 94	2181	2181
	50 Wolf	89 - 94	546 HF	2103
A	50	71 - 76	2015	2015
AC	50 DX	81 - 86	516 HF	2015
AC	50 RG, ZR, Z1	79 - 84	516 HF	2015
AE	50 R/L	88 - 93	101 HF	
AH	50 Adress	92 - 95	101 HF	2181
AJ	50 Sepia	92 - 96	102 HF	2181
AN	50	95 - 95	122 HF	
AP	50	75 - 78	2015	2015
AP	50	95 - 02	114 HF	2015
AY	50 , Katana	96 - 08	105 HF	2181
AY	50 , Katana	96 - 08	114 HF	2181

\* = 2 sets required / 2 jeux pour l'Avant.

Full compound selection, see under "Brake pad 1:1 Drawings" / Sélection complète de composés, voir "1:1 Schémas Plaquettes de frein".





**RECOMMENDED**

1xx - 2xx = Scooter Pads  
5xx - 9xx = Street, Off Road & Racing Pads  
2xxx = Brake Shoes



SUZUKI					
AY	50 W	00 - 04	123 HF	105 HF	
AY	50 WR	00 - 05	123 HF	105 HF	
CC	50 Tune	92 - 97	544 HF		
CL	50 D, Suzi, Love	83 - 83	2101	2020	
CP	50	85 - 90	101 HF		
CP	50 CHF	85 - 85	2181	2181	
CR	50 DC	87 - 87	101 HF		
CS	50 Roadie	83 - 83	2020	2020	
DR	50 Big	89 - 02	559 HF		
DR-Z	50	19 - 24	2010	2010	
F	50	71 - 73	2015	2015	
FA	50	80 - 91	2101	2101	
FR	50	74 - 81	2015	2015	
FS	50 Snip	80 - 81	2101	2101	
GSX-R	50	87 - 87	135 HF	2017	
GT	50	77 - 80	516 HF	2015	
JR	50	89 - 07	2020	2020	
LT	50	84 - 02		2020	
LT-A	50 Quadmaster	01 - 05	2101	2017	
LT-Z	50 QuadSport	06 - 20	2101*	2017	
OR	50	79 - 79	2015	2015	
OR	50	80 - 80	2017	2017	
OR	50 E	80 - 80	135 HF	2017	
PV	50	82 - 97	2014	2014	
RB	50	87 - 87	546 HF	2015	
RG	50 GAG	87 - 92	135 HF	2103	
RG	50 Gamma	90 - 96	135 HF	2103	
RM	50	75 - 76	503 HF	2015	
RM	50	78 - 80	2015	2015	
RM	50	81 - 82	2017	2017	
RME	50	10 - 10		777 HF	
RMX	50	00 - 02	105 HF	105 HF	
RV	50	72 - 82	2015	2015	
S	50 K	93 - 93	2103		
SMX	50 Super Motard	00 - 02	105 HF	105 HF	
TR	50 Street Magic	97 - 00	122 HF	2188	
TS	50	80 - 83	2015	2017	
TS	50	84 - 02	2103		
TS	50 ERA	80 - 80	2015	2015	
TS	50 ERZ1	80 - 83	2017	2017	
TS	50 KN	79 - 79	2015	2015	
TSW	50	91 - 91	2103		
TV	50 Wolf	89 - 91	135 HF	2103	
UF	50 Estilete	00 - 02	105 HF	2181	
UX	50 W Zillion	99 - 02	105 HF	2181	
X-1	50	79 - 79	516 HF	2015	
ZR	50	81 - 87	135 HF	2017	
ZZ	50 Scooter	92 - 92	101 HF	2181	
RM	60	03 - 03	2093	2093	
RM	65	03 - 06	752 RSI	536 RSI	
DR-Z	70	08 - 20	2010	2010	
FR	70	74 - 76	2015	2015	
LIDO	75 Style	84 - 94	544 HF	2181	
AH	80 Adress, V, Tune	88 - 91	101 HF	2181	
AH	80 Scooter	92 - 94	102 HF	2181	
CP	80	85 - 93	2181	2181	
DS	80	80 - 96	2017	2017	
FR	80	76 - 83	2015	2015	
GT	80 L/C	81 - 81	546 HF	2015	
JR	80	01 - 07	2017	2017	
LT	80	87 - 06	2101*	2104	
RG	80	85 - 87	587 HF	2014	
RG	80 Gamma	85 - 87	546 HF		
RG	80 Gamma	88 - 93	587 HF	2014	
RM	80	77 - 79	2015	2015	
RM	80	80 - 81	2017	2017	
RM	80	82 - 82	2022	2182	
RM	80	83 - 85	2014	2017	
RM	80	86 - 89	548 HF	2182	
RM	80	90 - 95	548 HF	544 SI	
RM	80	96 - 01	702 RSI	544 RSI	
RT	80	81 - 82	2015	2015	



**RECOMMENDED**

1xx - 2xx = Scooter Pads  
5xx - 9xx = Street, Off Road & Racing Pads  
2xxx = Brake Shoes



SUZUKI					
TS	80	81 - 82			2017
TS	80 X	84 - 87	2103		
ZZ	80 Sepia	90 - 92	544 HF		
RM	85	02 - 04	702 RSI	544 RSI	
RM	85	05 - 24	726 RSI	820 RSI	
LT-Z	90 QuadSport	07 - 20	2017*	2104	
RV	90	73 - 81	2015	2015	
TS	90	71 - 73	2015	2014	
A	100 all models	74 - 80	2014	2015	
ACC	100	70 - 72	2014	2014	
AH	100 V Adress	91 - 94	101 HF	2181	
AH	100 V Adress	95 - 96	122 HF		
ASS	100	69 - 71	2014	2015	
GP	100	78 - 92	538 HF	2015	
GT	100	78 - 78	503 HF		
RM	100	76 - 78	2015	2014	
RM	100	79 - 81	2015	2103	
RM	100	03 - 03	726 RSI	592 RSI	
TS	100	73 - 74	2015	2014	
TS	100	75 - 81	2014	2014	
TS	100 E	82 - 87	2014	2017	
	110 Smash	03 - 06	2015	2015	
DR-Z	110	02 - 06	2093	2015	
FX	110 Shogun	98 - 02	2015	2015	
UG	110 Hokuto	00 - 02	122 HF	2188	
UK	110 Adress	15 - 19	122 HF	2181	
TRS	118	82 - 83	546 HF		
B	120	71 - 77	2014	2014	
	125 Address	23 - 24	223 CT		
	125 Avensis	23 - 23	223 CT		
	125 Burgman Street EX	23 - 24	223 CT		
	125 Vecstar	94 - 97	122 CT	2181	
AH	125 V Adress	95 - 95	122 HF		
AN	125	06 - 08	101 CT	2181	
AN	125 R	94 - 05	122 CT	2181	
CS	125 D	83 - 85	2015	2015	
DR	125	82 - 84	2014	2014	
DR	125	86 - 02	536 HF	2014	
DR	125 SM	08 - 12	694 HF	604 HF	
DR-Z	125 K	03 - 12	2017	2017	
DR-Z	125 L	03 - 24	702 SI	2017	
EN	125	05 - 09	611 HF	2014	
GN	125	91 - 04	546 HF	2014	
GP	125 all models	77 - 84	524 HF	2014	
GP	125 C (Norway)	78 - 78	538 HF	2014	
GS	125	82 - 84	2014	2014	
GS	125 E, Katana	90 - 94	585 HF	2014	
GS	125 ESD	83 - 94	585 HF	2014	
GS	125 ESZ	82 - 82	546 HF	2014	
GSX-R	125 RL	17 - 24	951 HF	915 HF	
GSX-R	125 RLX	17 - 24	951 HF	915 HF	
GSX-S	125 ML	17 - 24	951 HF	915 HF	
GSX-S	125 MLX	17 - 24	951 HF	915 HF	
GT	125	75 - 77	503 HF	2014	
GT	125	78 - 79	515 HF	2014	
GT	125	80 - 82	546 HF	2014	
GX	125 R	88 - 03	536 HF	2014	
GZ	125 Marauder	00 - 11	581 HF	2014	
LIDO	125 Vario Scooter	90 - 93	101 CT	2181	
LT	125 D	83 - 83		2107	
LT	125 E-H	84 - 87		2016	
RG	125	79 - 80	515 HF	2014	
RG	125 F, Gamma	92 - 96	631 HF	635 HF	
RG	125 Gamma	85 - 90	587 HF	2014	
RG	125 Wolf	92 - 94	597 HF	556 HF	
RH	125 X	87 - 87	536 HF		
RM	125	75 - 78	2014	2014	
RM	125	79 - 80	2014	2103	
RM	125	81 - 83	2014	2102	
RM	125	84 - 84	2108	2102	
RM	125	85 - 86	581 HF	2102	
RM	125	87 - 87	611 SI	2102	

\* = 2 sets required / 2 jeux pour l'Avant.

Full compound selection, see under "Brake pad 1:1 Drawings" / Sélection complète de composés, voir "1:1 Schémas Plaquettes de frein".

**RECOMMENDED**1xx - 2xx = Scooter Pads  
5xx - 9xx = Street, Off Road & Racing Pads  
2xxx = Brake Shoes

SUZUKI					
RM	125	88 - 88	611 RSI	584 RSI	
RM	125	89 - 90	611 RSI	632 RSI	
RM	125	91 - 95	611 RSI	648 RSI	
RM	125	96 - 09	694 RSI	604 RSI	
RV	125 VanVan	03 - 18	704 HF		
SP	125	82 - 83	2014	2014	
SP	125	86 - 88	536 HF	2014	
SX	125	85 - 86	536 HF		
TR	125	83 - 86	546 HF		
TS	125	72 - 72	2015	2014	
TS	125	82 - 82	2014	2017	
TS	125	84 - 84	2014		
TS	125	85 - 86	536 HF	2103	
TS	125	89 - 96	611 HF	632 HF	
TU	125 XT	99 - 99	546 HF	2183	
UC	125 Epicuro	99 - 02	122 CT	2202	
UE	125	01 - 03	101 CT		
UH	125 Burgman	02 - 06	151 CT	157 CT	
UH	125 Burgman	07 - 14	192 CT	196 CT	
UH	125 Burgman	15 - 19	134 CT	196 CT	
UX	125 SIXteen	08 - 12	192 CT	196 CT	
VL	125 Intruder LC	00 - 08	581 HF		
X4	125 , X3E	78 - 80	546 HF	2014	
AN	150	98 - 01	122 CT	2181	
UC	150 Epicuro	99 - 02	122 CT	2202	
UE	150 CT	02 - 03	101 CT		
UH	150 Burgman	04 - 06	151 CT	157 CT	
UX	150 SIXteen	08 - 16	192 CT	196 CT	
LT	160	89 - 92	2181*	2016	
PE	175	82 - 82	2104		
GT	185	75 - 77	503 HF	2014	
LT	185	84 - 87		2016	
RG	185	75 - 77	503 HF		
TS	185	74 - 81	2014	2014	
	200 Wolf	92 - 96	597 HF	635 HF	
DR	200	86 - 88	536 SI	2014	
DR	200 S	15 - 17	536 SI	2014	
DR	200 SE	96 - 13	536 SI	2014	
DR	200 T	96 - 96	536 SI	2014	
GT	200 X5 (Nien)	79 - 82	515 HF	2014	
RG	200 Gamma	91 - 94	631 HS	635 LS	
RV	200 VanVan	16 - 19	704 HF		
SB	200	79 - 81	2016	2014	
SP	200	86 - 88	536 HF	2014	
SX	200 R	85 - 89	536 HF	2014	
TS	200 R	90 - 94	611 HF	632 HF	
UH	200	07 - 07	192 CT		
UH	200 Burgman	07 - 13	192 CT	196 CT	
UH	200 Burgman	14 - 18	134 CT	196 CT	
XS	200	79 - 79	515 HF	2014	
LT	230	86 - 93	591 SI*	592 SI	
LT-F	230	86 - 87	2051*	2016	
ET	240	86 - 86	546 HF		
RH	240 X	87 - 87	536 HF		
TS	240 X	85 - 90	536 HF	2103	
	250 Across	90 - 99	597 HF	556 HF	
	250 Bandit	90 - 96	597 HS	556 LS	
	250 Cobra	90 - 92	631 HS	556 LS	
	250 Djebel	93 - 95	597 HF	632 HF	
	250 Impulse	95 - 95	627 HS*		
	250 Sky Wave Type II	98 - 01	146 MS*	104 MS	
	250 Vecstar	94 - 94	122 CT	2181	
	250 Wolf	90 - 92	631 HS	556 LS	
AN	250 Burgman	98 - 03	146 MS	104 MS	
AN	250 Burgman	04 - 06	146 MS	174 MS	
DL	250 V-Strom	17 - 23	627 HF	657 HF	
DR	250	82 - 83	2014	2014	
DR	250	85 - 89	536 HF	2014	
DR	250	90 - 95	611 HF	632 HF	
DR-Z	250	01 - 07	694 SI	648 SI	
GF	250	88 - 88	578 HF*	556 HF	
GN	250	86 - 97	533 HF	2014	

**RECOMMENDED**1xx - 2xx = Scooter Pads  
5xx - 9xx = Street, Off Road & Racing Pads  
2xxx = Brake Shoes

SUZUKI					
GNX	250	82 - 84	533 HF	2018	
GS	250	80 - 82	533 HF	2018	
GSF	250 VS, S Bandit	95 - 00	705 HS		
GSX	250	80 - 80	533 HF	2018	
GSX	250	81 - 82	533 HF	512 HF	
GSX	250	85 - 85	534 HF	2018	
GSX	250	86 - 87	534 HF*	512 HF	
GSX	250 S, Katana	91 - 91	597 HS	556 LS	
GSX-R	250	88 - 89	577 HF*	556 HF	
GSX-R	250	17 - 23	627 HF	881 HF	
GSX-R	250 R	89 - 91	631 HS*	556 LS	
GT	250	73 - 77	503 HF	2097	
GT	250	78 - 81	515 HF	2018	
GW	250 Inazuma	12 - 19	627 HS	657 LS	
GW	250 Inazuma F	15 - 19	627 HS	881 LS	
GZ	250 Marauder	00 - 08	581 HF	2014	
LT	250	85 - 86	2051*	2098	
LT	250	85 - 87	591 SI*	584 SI	
LT	250	88 - 94	591 SI*	649 SI	
LT	250	89 - 90	591 SI*	592 SI	
LT-F	250	88 - 01	2053*	2110	
LT-F	250 4WD V, W Quadrunner	97 - 98	2053*	2098	
LT-F	250 Ozark	03 - 13	536 SI*		
LT-Z	250 Quad Sport	04 - 11	536 SI*		
NZ	250	86 - 91	546 HF	2183	
RG	250	78 - 82	515 HF		
RG	250	83 - 84	556 HF	556 HF	
RG	250 Gamma	84 - 88	578 HF*	556 HF	
RGV	250	88 - 88	624 HS*	556 LS	
RGV	250	89 - 90	631 HF*	556 HF	
RGV	250	93 - 95	631 HF*	615 HF	
RGV	250 Gamma	91 - 92	631 HF*	615 HF	
RH	250	85 - 87	536 HF		
RM	250	76 - 78	2014	2016	
RM	250	79 - 79	2016		
RM	250	80 - 80	2104		
RM	250	81 - 82	2107	2102	
RM	250	83 - 83	2108	2102	
RM	250	84 - 84	2108	2104	
RM	250	85 - 85	581 HF	2104	
RM	250	86 - 86	582 HF	2104	
RM	250	87 - 88	611 RSI	584 RSI	
RM	250	89 - 90	611 RSI	632 RSI	
RM	250	91 - 95	611 RSI	648 RSI	
RM	250	96 - 09	694 RSI	604 RSI	
RMX	250	89 - 95	611 RSI	648 RSI	
RMX	250	96 - 98	694 RSI	648 RSI	
RMX	250 X-K1	99 - 99	694 SI	604 SI	
RM-Z	250	04 - 24	694 RSI	790 RSI	
SP	250	85 - 85	536 HF	2014	
SW1	250	92 - 95	597 HS	2018	
TS	250	74 - 82	2016	2016	
TS	250 X	85 - 89	536 HF	2016	
TU	250 X	09 - 19	705 HF		
TU	250 X Super Classic	97 - 00	581 HF	2014	
TV	250	88 - 88	631 HF	556 HF	
VL	250 Intruder	00 - 07	581 HF	2014	
GS	300	82 - 85		2018	
LT	300	87 - 89	2051*	2098	
LT-F	300	88 - 90	2051	2052	
LT-F	300 King Quad	91 - 01		2052	
LT-F	300 King Quad Left	02 - 02	611 SI		
LT-F	300 King Quad Right	02 - 02	638 SI		
RL	325	80 - 82	2015	2014	
	350 Goose	92 - 99	631 HF	556 HF	
DR	350	90 - 99	611 HF	648 HF	
DR	350 V, W, X	97 - 99	694 SI	648 SI	
SP	370	77 - 79	2016	2016	
GT	380	73 - 77	503 HF	2097	
GT	380 Asco	77 - 77	515 HF	2097	
AN	400 Burgman	99 - 00	146 MS	104 MS	
AN	400 Burgman	01 - 06	146 MS	174 MS	

\* = 2 sets required / 2 jeux pour l'Avant.

Full compound selection, see under "Brake pad 1:1 Drawings" / Sélection complète de composés, voir "1:1 Schémas Plaquettes de frein".



**RECOMMENDED**

1xx - 2xx = Scooter Pads  
 5xx - 9xx = Street, Off Road & Racing Pads  
 2xxx = Brake Shoes



SUZUKI					
AN	400 Burgman Left	07 - 24	197 MS	182 MS	
AN	400 Burgman Right	07 - 24	134 MS		
DR	400	79 - 81	2016	2016	
DR-Z	400 S/E	00 - 23	694 HF	604 HF	
DR-Z	400 SM	05 - 24	694 RSI	604 RSI	
GN	400	80 - 80	533 HF	2018	
GS	400	77 - 78	511 HF	2097	
GS	400	79 - 82	515 HF	2097	
GSF	400 Bandit	91 - 92	597 HS*	556 LS	
GSF	400 Bandit	93 - 97	631 HS*	556 LS	
GSX	400	81 - 83	533 HF	2097	
GSX	400 E, S	85 - 86	534 HF	2018	
GSX	400 EFX	82 - 82	546 HF	2018	
GSX	400 F	81 - 84	533 HF*	512 HF	
GSX	400 F	89 - 92	620 HF*	556 HF	
GSX	400 FD	83 - 83	546 HF	512 HF	
GSX	400 FWS	83 - 83	556 HF*	556 HF	
GSX	400 FWS	86 - 87	534 HF*	512 HF	
GSX	400 FX, FZ	81 - 82	546 HF	512 HF	
GSX	400 Impulse	94 - 96	627 HS*	556 LS	
GSX	400 S, Katana	83 - 86	546 HF	2097	
GSX	400 S, Katana	92 - 92	631 HS*	556 LS	
GSX	400 X	86 - 89	577 HF*	556 HF	
GSX-R	400	87 - 87	577 HF*	556 HF	
GSX-R	400	88 - 89	631 HF*	556 HF	
GSX-R	400 F	85 - 86	578 HF*	556 HF	
GSX-R	400 R	90 - 95	624 HS*	556 LS	
KLT-A	400 King Quad Left	08 - 14	835 SI		
KLT-A	400 King Quad Right	08 - 14	836 SI		
KLT-F	400 King Quad Left	08 - 14	835 SI		
KLT-F	400 King Quad Right	08 - 14	836 SI		
LS	400 Savage	87 - 91	581 HF	2018	
LT-A	400 Eiger 2WD/4WD	02 - 07	536 SI*	2018	
LT-A	400 King Quad Left	08 - 14	835 SI		
LT-A	400 King Quad Right	08 - 14	836 SI		
LT-F	400 Eiger 2WD/4WD	02 - 07	536 SI*	2018	
LT-F	400 King Quad Left	08 - 14	835 SI		
LT-F	400 King Quad Right	08 - 14	836 SI		
LT-Z	400 Quad Sport	02 - 19	592 SI*	649 SI	
PE	400	79 - 81	2016	2016	
RF	400 RVC	93 - 97	627 HS	556 LS	
RM	400	78 - 78	2014	2016	
RM	400	79 - 79	2016		
RM	400	80 - 80	2104		
SP	400	80 - 82	2016	2016	
GS	425	79 - 79	511 HF	2018	
GS	425	80 - 80	515 HF	2018	
GS	450	80 - 83	533 HF	2018	
GS	450	85 - 85	534 HF	2018	
GS	450	86 - 86	546 HF*	512 HF	
GS	450	90 - 90	597 HS	597 LS	
LT-A	450 King Quad Left	08 - 14	835 SI		
LT-A	450 King Quad Right	08 - 14	836 SI		
LT-R	450 Left	06 - 12	611 SI	649 SI	
LT-R	450 Right	06 - 12	638 SI		
RMX	450 Z	10 - 18	694 SI	790 SI	
RM-Z	450	05 - 24	694 RSI	790 RSI	
RM	465	81 - 82	2107	2014	
DR	500	83 - 88	2016	2016	
DR	500	89 - 89	582 HF	2014	
GS	500	80 - 81	515 HF	512 HF	
GS	500	82 - 85	534 HF*	512 HF	
GS	500	89 - 95	597 HS	556 LS	
GS	500	96 - 03	704 HS	556 LS	
GS	500	04 - 08	704 HS	556 HF	
GS	500 E (Austria)	78 - 79	515 HF*	512 HF	
GS	500 E (Austria)	81 - 82	534 HF*	512 HF	
GS	500 F	04 - 08	704 HS	556 HF	
GSX	500	83 - 85	556 HF*	556 HF	
GT	500	73 - 75	515 HF	2098	
GT	500	75 - 77	503 HF	2098	
LT	500	87 - 95	591 SI*	649 SI	



**RECOMMENDED**

1xx - 2xx = Scooter Pads  
 5xx - 9xx = Street, Off Road & Racing Pads  
 2xxx = Brake Shoes



SUZUKI					
LT-A	500 F Vinson	02 - 02	536 SI*		
LT-A	500 FY Quadmaster Left	00 - 08	611 SI		
LT-A	500 FY Quadmaster Right	00 - 08	638 SI		
LT-A	500 King Quad Left	11 - 14	835 SI		
LT-A	500 King Quad Right	11 - 14	836 SI		
LT-F	500 F Left	98 - 07	638 SI		
LT-F	500 F Right	98 - 07	611 SI		
RG	500	85 - 87	577 HF*	556 HF	
RG	500 Gamma	85 - 86	577 HF*	556 HF	
RM	500	83 - 84	2108	2014	
RM	500	85 - 87	581 HF	2014	
RM	500	88 - 89	611 RSI	592 RSI	
GS	550	77 - 77	515 HF*	2099	
GS	550	78 - 79	515 HF*		
GS	550	80 - 82	534 HF*	512 HF	
GS	550	83 - 86	556 HF	556 HF	
GSX	550	83 - 87	556 HF*	556 HF	
GT	550	73 - 77	503 HF	2098	
GT	550	78 - 78	515 HF	2099	
DR	600 Djebel	86 - 88	582 HF	2014	
DR	600 Djebel	89 - 89	626 HF	635 HF	
DR	600 S Dakar	85 - 87	582 HF	2014	
GSF	600 Bandit	95 - 99	627 HS*	556 LS	
GSF	600 Bandit / S Bandit Left	00 - 04	705 HS	556 LS	
GSF	600 Bandit / S Bandit Right	00 - 04	704 HS		
GSR	600	06 - 10	631 HS*	833 LS	
GSX	600 F	89 - 97	620 HS*	556 LS	
GSX	600 FW Left	98 - 04	705 HS	556 LS	
GSX	600 FW Right	98 - 04	704 HS		
GSX	600 Katana	88 - 89	620 HF*	556 HF	
GSX	600 Katana	90 - 97	620 HS*	556 LS	
GSX-R	600	92 - 93	624 HS*	556 LS	
GSX-R	600	97 - 03	631 HS*	556 LS	
GSX-R	600	04 - 05	806 HS*	765 LS	
GSX-R	600	06 - 10	806 HS*	833 LS	
GSX-R	600	11 - 24	841 HS*	834 LS	
RF	600 R	93 - 96	627 HS*	556 LS	
SP	600 F	85 - 87	582 HF	2014	
VS	600 GL Intruder	97 - 97	577 HS	2052	
AN	650 A Burgman Executive	04 - 20	183 MS*	182 MS	
AN	650 Burgman	02 - 19	183 MS*	182 MS	
AN	650 Z Burgman Executive	13 - 19	183 MS*	182 MS	
DL	650 V-Strom Left	04 - 24	705 HS	657 LS	
DL	650 V-Strom Right	04 - 24	704 HS		
DL	650 V-Strom XT Left	15 - 24	705 HS	657 LS	
DL	650 V-Strom XT Right	15 - 24	704 HS		
DR	650	90 - 95	626 HS	635 LS	
DR	650 R	92 - 92	626 HS	635 LS	
DR	650 SE T-W	96 - 99	694 HF	648 HF	
GR	650	83 - 84	534 HF*	512 HF	
GR	650 X	83 - 84	534 HF	2018	
GS	650	81 - 83	534 HF*	512 HF	
GS	650 G	83 - 87	534 HF*	512 HF	
GS	650 Turbo, XN	83 - 85	534 HF*	512 HF	
GSF	650 Bandit	07 - 11	631 HS*	657 LS	
GSF	650 Bandit / S Bandit Left	05 - 05	705 HS	765 LS	
GSF	650 Bandit / S Bandit Right	05 - 05	704 HS		
GSF	650 Bandit / S Bandit ABS Left	06 - 06	705 HS	657 LS	
GSF	650 Bandit / S Bandit ABS Right	06 - 06	704 HS		
GSF	650 Bandit ABS	07 - 12	631 HS*	657 LS	
GSF	650 S Bandit	07 - 11	631 HS*	657 LS	
GSF	650 S Bandit ABS	07 - 13	631 HS*	657 LS	
GSX	650 F	08 - 18	631 HS*	657 HF	
GSX	650 GT	86 - 86	534 HF*	577 HF	
LS	650	05 - 05	581 HF	2018	
LS	650 P	86 - 88	581 HF	2018	
LS	650 P Savage	95 - 04	581 HF	2018	
SFV	650 Gladius Left	09 - 16	705 HS	881 LS	
SFV	650 Gladius Right	09 - 16	704 HS		
SV	650 Left	16 - 18	705 HS	881 LS	
SV	650 Right	16 - 18	704 HS		
SV	650	19 - 24	631 HS*	881 LS	

\* = 2 sets required / 2 jeux pour l'Avant.

Full compound selection, see under "Brake pad 1:1 Drawings" / Sélection complète de composés, voir "1:1 Schémas Plaquettes de frein".



**RECOMMENDED**1xx - 2xx = Scooter Pads  
5xx - 9xx = Street, Off Road & Racing Pads  
2xxx = Brake Shoes

SUZUKI					
SV	650 S Left	99	- 02	704 HS	
SV	650 S Right	99	- 02	705 HS	556 LS
SV	650 S Left	03	- 12	705 HS	657 LS
SV	650 S Right	03	- 12	704 HS	
SV	650 S ABS	07	- 18	705 HS	657 LS
SV	650 X Left	18	- 18	705 HS	881 LS
SV	650 X Right	18	- 18	704 HS	
SV	650 X	19	- 24	631 HS*	881 LS
XF	650 Freewind	97	- 02	704 HS	614 LS
GS	700	85	- 85	533 HF*	512 HF
GV	700 GLG Madura	86	- 86	533 HF*	2052
LT-A	700 King Quad Left	05	- 11	835 SI	
LT-A	700 King Quad Right	05	- 11	836 SI	
LT-V	700 Quadrunner Twin Peaks Left	04	- 06	801 SI	
LT-V	700 Quadrunner Twin Peaks Right	04	- 06	798 SI	
VS	700 GLFG	86	- 87	577 HF	2052
DR	750 Big	89	- 90	626 HS	635 LS
DR	750 S, Big	88	- 88	626 HF	2111
GS	750	76	- 77	511 HF	512 HF
GS	750	78	- 79	515 HF*	512 HF
GS	750 D	77	- 79	511 HF*	512 HF
GS	750 E	77	- 79	511 HF*	512 HF
GS	750 Katana	85	- 86	556 HF*	556 HF
GS	750 RF	85	- 85	577 HF*	556 HF
GS	750 SD	83	- 83	534 HF*	512 HF
GSR	750 Left	11	- 16	705 HS	657 LS
GSR	750 Right	11	- 16	704 HS	
GSX	750	89	- 97	620 HS*	556 LS
GSX	750 Left	98	- 08	705 HS	556 LS
GSX	750 Right	98	- 08	704 HS	
GSX	750 E	82	- 83	533 HF*	512 HF
GSX	750 EF	80	- 86	533 HF*	512 HF
GSX	750 ES	83	- 85	533 HF*	512 HF
GSX	750 ES	84	- 85	556 HF*	556 HF
GSX	750 ES, EF, STS	86	- 88	534 HF*	512 HF
GSX	750 F Left	03	- 06	705 HS	556 LS
GSX	750 F Right	03	- 06	704 HS	
GSX	750 FW Left	98	- 02	705 HS	556 LS
GSX	750 FW Right	98	- 02	704 HS	
GSX	750 Katana	89	- 96	620 HS*	556 LS
GSX	750 L	80	- 82	533 HF*	512 HF
GSX	750 S	82	- 82	533 HF*	512 HF
GSX	750 S, Katana	85	- 86	534 HF*	512 HF
GSX-R	750	85	- 87	577 HF*	556 HF
GSX-R	750	88	- 93	624 HS*	556 LS
GSX-R	750	94	- 99	686 HS*	556 LS
GSX-R	750	00	- 03	631 HS*	556 LS
GSX-R	750	04	- 05	806 HS*	765 LS
GSX-R	750	06	- 10	806 HS*	833 LS
GSX-R	750	11	- 23	841 HS*	834 LS
GSX-S	750 Left	15	- 16	705 HS	657 LS
GSX-S	750 Right	15	- 16	704 HS	
GSX-S	750	17	- 20	782 HS*	657 LS
GSX-S	750 Z Left	15	- 16	705 HS	657 LS
GSX-S	750 Z Right	15	- 16	704 HS	
GT	750	73	- 77	503 HF*	2098
LT-A	750 King Quad Left	08	- 14	835 SI	
LT-A	750 King Quad Right	08	- 14	836 SI	
VS	750 Intruder	86	- 91	577 HF*	2052
C	800 Intruder	05	- 18	704 HS	2052
DL	800 V-Strom DE	23	- 24	627 HS*	657 LS
DL	800 V-Strom SE	24	- 24	782 HS*	657 LS
DR	800 S, Big	90	- 90	626 HS	635 LS
DR	800 S, Big	91	- 95	597 HS	638 LS
DR	800 ST Big	96	- 98	705 HS	638 LS
DR-Z	800	88	- 90	626 HS	592 LS
GSX-8R	800	24	- 24	782 HS*	657 LS
GSX-8S	800	23	- 24	782 HS*	657 LS
M	800 Intruder	05	- 18	704 HS	2052
VL	800 Intruder LC Volusia	01	- 04	704 HS	2052
VS	800 Intruder	91	- 99	577 HS	2052
VX	800 L-P	90	- 93	597 HS	620 LS

**RECOMMENDED**1xx - 2xx = Scooter Pads  
5xx - 9xx = Street, Off Road & Racing Pads  
2xxx = Brake Shoes

SUZUKI					
VZ	800 Marauder	97	- 04	704 HS	2052
GS	850	79	- 80	511 HF*	512 HF
GS	850	81	- 82	533 HF*	512 HF
GS	850 G	83	- 86	533 HF*	512 HF
GSX	850 G	83	- 85	533 HF	512 HF
XN	850	83	- 85	534 HF*	512 HF
RF	900 RR,RS,RS2,T,V	94	- 97	714 HS*	701 LS
GSX-S	950	22	- 24	806 HS*	657 LS
DL	1000 V-Strom Left	02	- 13	705 HS	657 LS
DL	1000 V-Strom Right	02	- 13	704 HS	
DL	1000 V-Strom	14	- 19	806 HS*	833 LS
DL	1000 V-Strom XT	17	- 19	806 HS*	833 LS
DL	1000 V-Strom XT Adventure	19	- 19	806 HS*	833 LS
G	1000 SZ	82	- 82	534 HF*	512 HF
GS	1000	78	- 79	515 HF*	512 HF
GS	1000	80	- 81	533 HF*	512 HF
GS	1000 ET	81	- 81	534 HF*	512 HF
GS	1000 EX	81	- 81	534 HF*	512 HF
GSX	1000 S, Katana	82	- 84	534 HF*	512 HF
GSX-R	1000	01	- 02	686 HS*	765 LS
GSX-R	1000	03	- 03	788 HS*	765 LS
GSX-R	1000	04	- 06	806 HS*	765 LS
GSX-R	1000	07	- 08	806 HS*	833 LS
GSX-R	1000	09	- 11	806 HS*	834 LS
GSX-R	1000	12	- 24	841 HS*	834 LS
GSX-R	1000 R	17	- 24	841 HS*	834 LS
GSX-S	1000	15	- 24	841 HS*	657 LS
GSX-S	1000 F	15	- 23	841 HS*	657 LS
GSX-S	1000 GT	22	- 24	841 HS*	657 LS
GSX-S	1000 GX	24	- 24	841 HS*	657 LS
GSX-S	1000 Katana	19	- 24	841 HS*	657 LS
SV	1000 , S	03	- 07	631 HS*	657 LS
TL	1000 RW	98	- 02	686 HS*	556 LS
TL	1000 S V-Twin	97	- 01	631 HS*	556 LS
DL	1050 V-Strom	20	- 24	806 HS*	833 LS
DL	1050 V-Strom DE	23	- 24	806 HS*	833 LS
DL	1050 V-Strom XT	20	- 24	806 HS*	833 LS
GS	1100	81	- 81	534 HF*	512 HF
GS	1100	82	- 83	533 HF*	512 HF
GS	1100 ED, ESD, GD	83	- 83	534 HF*	512 HF
GS	1100 G	86	- 88	534 HF*	512 HF
GS	1100 GKD, SD, GLD	83	- 83	534 HF*	512 HF
GS	1100 L	79	- 79	534 HF*	512 HF
GSX	1100	85	- 85	577 HF*	577 HF
GSX	1100	86	- 86	534 HF*	512 HF
GSX	1100	86	- 87	556 HF*	556 HF
GSX	1100	88	- 89	620 HF*	577 HF
GSX	1100	90	- 93	620 HS*	577 LS
GSX	1100	91	- 93	597 HS*	620 LS
GSX	1100 E	82	- 84	534 HF*	512 HF
GSX	1100 E, L	79	- 81	534 HF	512 HF
GSX	1100 F	93	- 96	620 HS*	556 LS
GSX	1100 G	94	- 95	597 HS*	615 LS
GSX	1100 G Left	96	- 98	705 HS	556 LS
GSX	1100 G Right	96	- 98	704 HS	
GSX	1100 Katana	93	- 93	624 HS*	556 LS
GSX	1100 S	82	- 83	534 HF*	512 HF
GSX-R	1100	86	- 88	577 HF*	556 HF
GSX-R	1100	89	- 92	624 HS*	556 LS
GSX-R	1100	93	- 97	686 HS*	556 LS
GT	1100	80	- 80	534 HF*	512 HF
GS	1150 EG	86	- 87	577 HF*	577 HF
GS	1150 ES	84	- 85	577 HF*	577 HF
GSF	1200 Bandit	95	- 96	624 HS*	556 LS
GSF	1200 Bandit	97	- 00	714 HS*	556 LS
GSF	1200 Bandit	01	- 05	686 HS*	556 LS
GSF	1200 Bandit	06	- 06	631 HS*	657 LS
GSF	1200 S Bandit	01	- 05	686 HS*	556 LS
GSF	1200 S Bandit	06	- 06	631 HS*	657 LS
GSX	1200	99	- 01	706 HS*	556 LS
GV	1200 GLG Madura	86	- 86	533 HF*	512 HF
GSF	1250 A Bandit	07	- 18	631 HS*	657 LS

\* = 2 sets required / 2 jeux pour l'Avant.

Full compound selection, see under "Brake pad 1:1 Drawings" / Sélection complète de composants, voir "1:1 Schémas Plaquettes de frein".



**RECOMMENDED**

1xx - 2xx = Scooter Pads  
 5xx - 9xx = Street, Off Road & Racing Pads  
 2xxx = Brake Shoes



**SUZUKI**

GSF	1250 Bandit	06 - 18	631 HS*	657 LS
GSF	1250 F Bandit	12 - 18	631 HS*	657 LS
GSF	1250 S Bandit	06 - 18	631 HS*	657 LS
GSF	1250 SA Bandit	07 - 18	631 HS*	657 LS
GSX	1250 FA Bandit	16 - 18	631 HS*	657 LS
GSX	1250 FA Traveller	15 - 16	631 HS*	657 LS
	1300 B-King	07 - 07	838 HS*	657 LS
GSX-R	1300 Hayabusa	99 - 07	686 HS*	556 LS
GSX-R	1300 Hayabusa	08 - 12	806 HS*	833 LS
GSX-R	1300 Hayabusa	13 - 24	841 HS*	833 LS
GSX-R	1300 Hayabusa (Red Call)	13 - 21	841 HS*	833 LS
	1340 B-King	08 - 14	782 HS*	833 LS
GL	1400 Cavalcade	87 - 88	620 HF*	577 HF
GSX	1400	02 - 07	686 HS*	765 LS
GV	1400 Cavalcade	85 - 86	534 HF*	512 HF
GV	1400 Cavalcade LXE	87 - 90	577 HS*	577 LS
VS	1400 GL Intruder	87 - 04	577 HS	577 LS
C	1500 Intruder Left	05 - 10	705 HS	789 LS
C	1500 Intruder Right	05 - 10	704 HS	
C	1500 T Intruder	13 - 18	627 HS	886 LS
M	1500 Intruder Left	09 - 18	705 HS	886 LS
M	1500 Intruder Right	09 - 18	704 HS	
VL	1500 Intruder LC	98 - 01	577 HS	577 LS
VL	1500 Intruder LC Left	02 - 02	705 HS	789 LS
VL	1500 Intruder LC Right	02 - 02	704 HS	
M	1600 Intruder	05 - 07	788 HS*	886 LS
VZ	1600 Marauder	04 - 04	686 HS*	886 LS
C	1800 R Intruder	08 - 11	828 HS*	920 LS
M	1800 R Intruder	06 - 16	806 HS*	920 LS
M	1800 R2 Intruder	08 - 10	806 HS*	920 LS
M	1800 RBZ Intruder	16 - 17	806 HS*	920 LS

**SWM**

	125 Ace of Spades	20 - 20	873 HF	
	125 GP	86 - 86	519 HF*	519 HF
	125 Gran Milano Outlaw	20 - 20	873 HF	791 HF
	125 Outlaw	20 - 20	873 HF	998 HF
	125 S1-S2	83 - 83	519 HF	
	125 Varez	20 - 20	873 HF	998 HF
RS	125 R	18 - 20	873 HF	998 HF
SM	125 R	18 - 20	873 HF	998 HF
	250 Explorer	86 - 86	519 SI	519 SI
	250 Pioner	86 - 86	519 SI	519 SI
	250 S1-S2	83 - 83	519 HF	
RS	300 R	15 - 20	671 SI	791 SI
TRL	329 MJ	86 - 86	519 RSI	
XP	350 Sahara	83 - 83	506 HF	
	400 Varez	20 - 20	900 HS	791 HF
	440 Gran Milano	15 - 17	627 HS	998 HF
	440 Gran Milano	18 - 18	762 HS	998 HF
	440 Gran Turismo	15 - 17	627 HS	998 HF
	440 Silver Vase	15 - 17	627 HS	998 HF
SM	450 R	15 - 17	762 HS	791 HF
	500 Ace of Spades	18 - 21	762 HS	998 HF
	500 Gran Milano Outlaw	18 - 21	762 HS	998 HF
RS	500 R	15 - 20	671 SI	791 SI
SM	500 R	18 - 20	762 HS	791 HF
	600 Superdual GT Pack	18 - 18	674 HS	675 LS
	600 Superdual T	18 - 20	674 HS	675 LS
	600 Superdual X	18 - 20	674 HS	675 LS
	650 Superdual	15 - 18	762 HS	675 LS

**SYM**

	50 Allo	11 - 15	140 HF	
	50 Bullet	93 - 93	110 HF	
	50 Cinderella	01 - 00	110 HF	
	50 Crox	14 - 15	140 CT	
	50 Feel-big	98 - 98	618 HF	
	50 Fiddle	09 - 14	140 HF	2012
	50 Fiddle III	16 - 19	140 CT	202 CT
	50 Jet 4 Naked	11 - 13	140 HF	
	50 Jet 4 R	11 - 13	140 HF	



**RECOMMENDED**

1xx - 2xx = Scooter Pads  
 5xx - 9xx = Street, Off Road & Racing Pads  
 2xxx = Brake Shoes



**SYM**

	50 Jet BasiX	07 - 09	140 HF	
	50 Jet Euro X	05 - 12	140 HF	
	50 Jet Sport X	06 - 14	140 HF	
	50 Jet Sport X SR	06 - 14	140 HF	129 HF
	50 Jet, Alpha	95 - 97	140 HF	2012
	50 Jungle	96 - 02	140 HF	2012
	50 Mask	00 - 05	140 HF	2012
	50 Mask LC	00 - 05	140 HF	2012
	50 Mio	05 - 16	110 HF	2057
	50 Orbit II	12 - 13	140 HF	
	50 Pure	98 - 98	618 HF	
	50 Red Devil	97 - 09	140 HF	2012
	50 Super Fancy	95 - 97	140 HF	2012
	50 Super Fancy	98 - 06	115 HF	
	50 Symphony	09 - 15	140 HF	
	50 Symphony SR	11 - 15	140 HF	
	50 Symphony ST	15 - 15	140 CT	
	50 Symply	08 - 14	140 HF	
	50 X'Pro	13 - 17	140 HF	
DD	50	02 - 12	110 HF	2057
RS	50	05 - 09	178 HF	2012
RS21	50	02 - 09	178 HF	
	100 Cinderella	01 - 01	110 HF	
	100 Jet	00 - 00	140 HF	
	100 Jet Euro X	05 - 05	140 HF	
	100 Jet Sport X	05 - 05	140 HF	
	100 Mio	05 - 16	110 HF	
	100 Party	97 - 00	140 HF	
	100 Super Fancy	95 - 00	140 HF	2012
	110 Bullet	93 - 93	542 HF	
	110 Star	03 - 03	140 HF	
	125 Aero Wolf	02 - 02	542 HF	
	125 Allo	11 - 15	140 CT	
	125 Attila	95 - 02	708 HF	2012
	125 Citycom	09 - 14	140 CT	
	125 Crox	14 - 15	140 CT	
	125 Euro MX	03 - 04	178 CT	
	125 Fiddle	09 - 16	140 CT	
	125 Fiddle III	16 - 19	140 CT	202 CT
	125 GTS	07 - 11	146 CT	
	125 Husky	96 - 98	135 CT	2188
	125 Husky	99 - 05	150 CT	
	125 Jet 14	17 - 19	140 CT	202 CT
	125 Jet 4	11 - 13	140 HF	
	125 Jet X	24 - 24	140 CT	202 CT
	125 Joymax Sport	16 - 16	146 CT	201 CT
	125 Joyride	01 - 06	178 CT	154 CT
	125 Joyride	07 - 09	178 CT	201 CT
	125 Joyride Evo	10 - 12	178 CT	201 CT
	125 Joyride S	16 - 17	178 CT	201 CT
	125 Megalo	02 - 05	140 CT	
	125 New Duke	02 - 07	140 CT	
	125 Super Duke	95 - 01	140 CT	2188
	125 Symphony	09 - 15	140 CT	
	125 Symphony EX	17 - 17	140 CT	
	125 Symphony S	11 - 17	140 CT	202 CT
	125 Symphony SR	11 - 17	140 CT	202 CT
	125 Symphony ST	15 - 19	140 CT	202 CT
	125 Symply	08 - 14	140 CT	
	125 Voyager	05 - 05	171 CT	
	125 Wolf Classic	05 - 05	551 HF	
	125 Wolf Legend	02 - 05	103 CT	
	125 X'Pro	14 - 16	140 CT	
HD	125	04 - 10	154 CT	
HD	125 Evo DT	10 - 10	140 CT	201 CT
HD2	125 Evo	14 - 14	140 CT	201 CT
NH	125 T	19 - 19	663 HF	
NH	125 X	19 - 19	663 HF	
RS	125	05 - 06	178 CT	119 CT
RS21	125 , R	02 - 02	178 CT	
SB	125 Wolf Ni	11 - 13	847 HF	810 HF
VS	125	07 - 08	792 HF	

\* = 2 sets required / 2 jeux pour l'Avant.

Full compound selection, see under "Brake pad 1:1 Drawings" / Sélection complète de composés, voir "1:1 Schémas Plaquettes de frein".

**RECOMMENDED**1xx - 2xx = Scooter Pads  
5xx - 9xx = Street, Off Road & Racing Pads  
2xxx = Brake Shoes

SYM					
VS	125	09 - 13	178 CT		
	150 Attila	00 - 03	140 CT		
	150 Crox	14 - 16	140 CT		
	150 Euro MX	03 - 06	178 CT		
	150 Husky	99 - 02	150 CT	2188	
	150 Husky ADV	22 - 22	178 CT		
	150 Jet 4	11 - 14	140 HF		
	150 Joyride	01 - 06	178 CT	154 CT	
	150 Super Duke	96 - 01	140 CT	2012	
	150 Symphony S	11 - 15	140 CT	202 CT	
	150 Symphony SR	11 - 15	140 CT	202 CT	
H01	150	95 - 00	708 HF		
RS	150	05 - 06	178 CT	119 CT	
VS	150	07 - 15	792 HF		
MF	180	03 - 03	551 HF		
	200 Fiddle II	11 - 13	140 CT		
	200 Fiddle III	16 - 19	140 CT	202 CT	
	200 Joyride	01 - 08	178 CT	154 CT	
	200 Joyride Evo	09 - 15	140 CT		
	200 Joyride S	16 - 17	178 CT	201 CT	
	200 Quadlander	12 - 13	810 SI*	847 SI	
	200 Trackrunner	05 - 08	810 SI*	847 SI	
HD	200	04 - 06	154 CT		
HD	200 Evo	07 - 13	140 CT	201 CT	
HD2	200 Evo	14 - 14	140 CT	201 CT	
	250 GTS	07 - 11	146 MS	201 MS	
	250 Joymax	07 - 10	171 MS	201 MS	
	250 Joymax Sport	16 - 17	146 MS	201 MS	
	250 Quadlander	06 - 07	810 SI*	847 SI	
	250 Voyager	05 - 05	171 MS		
RV	250 Efi	10 - 10	171 MS	201 MS	
SN	250 Ni Wolf	14 - 15	893 HF	810 HF	
SN	250 T2 Wolf	12 - 15	893 HF		
	300 City Max	06 - 07	810 SI*	847 SI	
	300 Citycom	09 - 15	140 CT	140 CT	
	300 Citycom S	15 - 17	140 CT	140 CT	
	300 Cruisym	17 - 17	215 MS	201 MS	
	300 Joymax Evo	10 - 12	171 MS	201 MS	
	300 Joymax Sport	16 - 17	171 MS	201 MS	
	300 Joyride	22 - 22	178 CT		
	300 Joyride Evo i	10 - 10	146 MS	201 MS	
	300 Quadlander	06 - 13	810 SI*	810 SI	
	300 Wolf Cafe Racer	15 - 15	893 HF	810 HF	
	300 Wolf Classic	15 - 15	893 HF	810 HF	
GTS	300	09 - 13	171 MS	201 MS	
GTS	300 Evo i	11 - 15	146 MS	201 MS	
SB	300 Cafe Racer	16 - 17	893 HF	810 HF	
	400 i Maxsym	11 - 17	215 MS*	218 MS	
	400 Maxsym GT	24 - 24	215 MS	218 MS	
	465 Maxsym TL	20 - 20	215 MS*	218 MS	
	500 GT	07 - 04	146 MS	154 MS	
TL	508 Maxsym TCS	22 - 22	215 MS*	218 MS	
	600 i Maxsym	14 - 19	215 MS*	218 MS	
	600 i Maxsym Sport	18 - 19	215 MS*	218 MS	
	600 Quad Raider	08 - 15	810 SI*	810 SI	
<b>TGB</b>					
	50 101R	05 - 09	101 HF		
	50 101S	99 - 02	101 HF	2188	
	50 202T	99 - 02	101 HF		
	50 203	05 - 08	163 HF		
	50 303R	99 - 14	101 HF		
	50 309 Racing	05 - 05	101 HF		
	50 507	05 - 05	101 HF		
	50 Akros	99 - 04	101 HF		
	50 Akros tec 5	99 - 04	163 HF		
	50 Apollo	99 - 03	163 HF		
	50 Buffalo	03 - 03		688 HF	
	50 Bull&t RS/RR	11 - 17	203 HF	101 HF	
	50 Bullet	09 - 09	101 HF	101 HF	
	50 Bullet	10 - 12	203 HF		
	50 Bunny	97 - 00	101 HF		

**RECOMMENDED**1xx - 2xx = Scooter Pads  
5xx - 9xx = Street, Off Road & Racing Pads  
2xxx = Brake Shoes

TGB					
	50 Corona	03 - 05	132 HF		
	50 Double X	05 - 05	101 HF		
	50 Ergon	96 - 00	101 HF		
	50 Fire, Sky	03 - 05	163 HF		
	50 Hawk	09 - 14	101 HF		
	50 Hiw's	99 - 99	101 HF		
	50 Hook	10 - 12	101 HF		
	50 J409	00 - 03	101 HF		
	50 Tapo RS	11 - 12	101 HF		
	50 Trigger	99 - 03	101 HF		
GT	50 Veloce	09 - 12	141 HF		
R	50 X	06 - 14	132 HF	101 HF	
	90 101S	99 - 02	101 HF		
	90 202T	99 - 02	101 HF		
	90 Akros	99 - 99	101 HF		
	90 Apollo	99 - 02	163 HF		
	90 Ergon	99 - 02	101 HF		
	90 Hiw's	99 - 99	101 HF		
	90 Trigger	99 - 02	101 HF		
	125 101S	99 - 03	101 CT		
	125 202T	99 - 99	101 CT		
	125 303R	99 - 08	101 CT		
	125 309 RS	00 - 00	101 HF		
	125 Bull&t RS/RR	11 - 14	203 HF	101 HF	
	125 Hook	10 - 10	101 HF		
	125 X-Large	11 - 11	210 CT	201 CT	
	125 X-Motion	08 - 12	210 CT	201 CT	
	250 Dynasty	06 - 06	163 CT	111 CT	
	250 X-Motion	08 - 09	210 MS	201 CT	
	300 X-Motion	10 - 12	210 MS	201 CT	
<b>TM</b>					
	80 Cross	96 - 00	671 RSI	675 RSI	
	80 Junior	96 - 00	544 RSI	592 RSI	
MX	85	01 - 12	671 RSI	604 RSI	
MX	85	13 - 24	777 RSI	777 RSI	
SM	85	18 - 19	777 RSI	777 RSI	
EN	125 Enduro	01 - 04	671 SI	604 SI	
EN	125 Enduro	05 - 22	671 SI	790 SI	
MX	125	96 - 00	671 RSI	675 RSI	
MX	125	01 - 04	671 RSI	604 RSI	
MX	125	05 - 24	671 RSI	790 RSI	
SMR	125	05 - 05	566 RSI	604 RSI	
MX	144	08 - 24	671 RSI	790 RSI	
	250 E	95 - 00	671 RSI	675 RSI	
EN	250 Enduro	01 - 04	671 SI	604 SI	
EN	250 Enduro	05 - 22	671 SI	790 SI	
EN	250 F Enduro	00 - 00	671 SI	675 SI	
EN	250 F Enduro	01 - 04	671 SI	604 SI	
EN	250 F Enduro	05 - 22	671 SI	790 SI	
MX	250	01 - 04	671 RSI	604 RSI	
MX	250	05 - 24	671 RSI	790 RSI	
MX	250 F	01 - 04	671 RSI	604 RSI	
MX	250 F	05 - 24	671 RSI	790 RSI	
EN	300 Enduro	01 - 04	671 SI	604 SI	
EN	300 Enduro	05 - 05	671 SI	790 SI	
FT	300	17 - 19	671 RSI	790 RSI	
MX	300	98 - 00	671 RSI	675 RSI	
MX	300	01 - 04	671 RSI	604 RSI	
MX	300	05 - 24	671 RSI	790 RSI	
	320	96 - 97	671 RSI	675 RSI	
	400 F	00 - 00	671 RSI	675 RSI	
	400 F	01 - 01	671 RSI	604 RSI	
	400 F Enduro	01 - 01	671 SI	604 SI	
SMF	400 F	02 - 02	566 RSI	604 RSI	
SMR	400 F	03 - 03	566 RSI	604 RSI	
EN	450 F Enduro	02 - 04	671 SI	604 SI	
EN	450 F Enduro	05 - 22	671 SI	790 SI	
FT	450 Fi	17 - 19	671 RSI	790 RSI	
MX	450 F	02 - 04	671 RSI	604 RSI	
MX	450 F	05 - 24	671 RSI	790 RSI	
SMR	450 F	04 - 04	566 RSI	604 RSI	

\* = 2 sets required / 2 jeux pour l'Avant.

Full compound selection, see under "Brake pad 1:1 Drawings" / Sélection complète de composants, voir "1:1 Schémas Plaquettes de frein".





**RECOMMENDED**

1xx - 2xx = Scooter Pads  
5xx - 9xx = Street, Off Road & Racing Pads  
2xxx = Brake Shoes



TM					
SMX	450 F	03 - 03	566 RSI	604 RSI	
SMX	450 F	04 - 04	762 RST	604 RSI	
EN	530 F Enduro	01 - 04	671 SI	604 SI	
EN	530 F Enduro	05 - 05	671 SI	790 SI	
FT	530 Fi	17 - 19	671 RSI	790 RSI	
MX	530 F	01 - 04	671 RSI	604 RSI	
MX	530 F	05 - 24	671 RSI	790 RSI	
SMR	530 F	03 - 03	566 RSI	604 RSI	
SMX	600 F	03 - 03	566 RSI	604 RSI	
SMX	660 F	04 - 04	762 RST	604 RSI	

**TOMOS**

	50 Hip Hop	06 - 08	105 HF		
	50 Racing	06 - 08	105 HF		
	50 Revival	02 - 04	123 HF		
	50 Street Soul	06 - 08	105 HF		
	50 Streetmate	03 - 05	123 HF		
	50 Youngst'r	06 - 08	105 HF		
BT	50 S	89 - 89	595 HF		
MC	50 Senior Pro	04 - 06	667 HF	667 HF	
N	50 AT, BT	91 - 95	595 HF		
SE	50	05 - 06	148 HF	105 HF	
CTX	80	89 - 89	595 HF		
MC	125 T	06 - 08	817 HF	559 HF	
SE	125	05 - 08	817 HF	559 HF	
SM	125 F	06 - 08	821 HS	559 HF	

**TORNAX**

RX	80	83 - 83	519 HF		
----	----	---------	--------	--	--

**TRIUMPH**

TF	250 X	24 - 24	671 RSI	791 RSI	
	400 Scrambler X	24 - 24	877 HS	675 LS	
	400 Speed	24 - 24	877 HS	675 LS	
	600 Daytona	03 - 04	624 HS*	614 LS	
	600 Speed Four	03 - 06	624 HS*	614 LS	
TT	600	00 - 03	624 HS*	614 LS	
	650 Daytona	05 - 06	624 HS*	614 LS	
	660 Street Triple S	17 - 20	627 HS*	675 LS	
	660 Tiger Sport	22 - 23	627 HS*	614 LS	
	660 Trident	21 - 23	627 HS*	614 LS	
	675 Daytona	06 - 08	782 HS*	614 LS	
	675 Daytona R Triple	11 - 12	901 HS*	614 LS	
	675 Daytona R Triple	13 - 18	901 HS*	675 LS	
	675 Daytona Triple	09 - 12	864 HS*	614 LS	
	675 Daytona Triple	13 - 18	864 HS*	675 LS	
	675 Street Triple	08 - 12	627 HS*	614 LS	
	675 Street Triple	13 - 17	627 HS*	675 LS	
	675 Street Triple R	09 - 12	782 HS*	614 LS	
	675 Street Triple R	13 - 17	782 HS*	675 LS	
	675 Street Triple RX	15 - 16	782 HS*	675 LS	
	750 Bonneville	84 - 84	554 HF		
	750 Bonneville U.K.	87 - 87	506 HF*	506 HF	
	750 Daytona	91 - 92	624 HS*	633 LS	
	750 Trident Left	91 - 98	611 HS	611 LS	
	750 Trident Right	91 - 98	638 HS		
	750 Trident T160V	75 - 77	523 HF	523 HF	
T140	750 D,E,F,V Bonneville	76 - 81	523 HF	523 HF	
T140	750 ES Bonneville	81 - 83	523 HF*	523 HF	
TR65	750 Thunderbird	81 - 83	523 HF		
TR7T	750 Tiger Trail	81 - 83	523 HF		
TR7V	750 Tiger	73 - 81	523 HF	523 HF	
TSS	750	83 - 83	523 HF*	523 HF	
TSS	750 Electro Eight Valve	84 - 84	523 HF		
TSX	750	83 - 83	523 HF	523 HF	
	765 Daytona Moto2	20 - 22	901 HS*	675 LS	
	765 Street Triple R	17 - 23	900 HS*	675 LS	
	765 Street Triple R Low	17 - 23	900 HS*	675 LS	
	765 Street Triple RS	17 - 23	901 HS*	675 LS	
	765 Street Triple S	17 - 20	627 HS*	675 LS	
	800 America	03 - 06	627 HS	611 LS	
	800 Bonneville	01 - 04	627 HS	611 LS	



**RECOMMENDED**

1xx - 2xx = Scooter Pads  
5xx - 9xx = Street, Off Road & Racing Pads  
2xxx = Brake Shoes



TRIUMPH					
	800 Bonneville America	02 - 06	627 HS	611 LS	
	800 Bonneville Speedmaster	03 - 04	627 HS*	611 LS	
	800 Bonneville T100 Centennial Edition	02 - 04	627 HS	611 LS	
	800 Bonneville T100 Paul Smith	06 - 08	627 HS	611 LS	
	800 Tiger	11 - 14	627 HS*	614 LS	
	800 Tiger XC	11 - 17	627 HS*	614 LS	
	800 Tiger XC ABS	12 - 14	627 HS*	614 LS	
	800 Tiger XCA	15 - 17	627 HS*	614 LS	
	800 Tiger XCA	18 - 18	671 HS*	614 LS	
	800 Tiger XCR	15 - 17	627 HS*	614 LS	
	800 Tiger XCX	18 - 20	671 HS*	614 LS	
	800 Tiger XR	15 - 18	627 HS*	614 LS	
	800 Tiger XRT	15 - 17	627 HS*	614 LS	
	800 Tiger XRT	18 - 18	671 HS*	614 LS	
	800 Tiger XRX	15 - 17	627 HS*	614 LS	
	800 Tiger XRX	18 - 18	671 HS*	614 LS	
	800 Tiger XRX Low	18 - 20	671 HS*	614 LS	
	850 Tiger Sport	21 - 23	901 HS*	675 LS	
	900 Adventurer	96 - 02	627 HS	700 LS	
	900 America	07 - 16	627 HS	611 LS	
	900 Bonneville	05 - 08	627 HS	638 LS	
	900 Bonneville	09 - 11	627 HS	611 LS	
	900 Bonneville Newchurch	15 - 15	627 HS	611 LS	
	900 Bonneville SE	09 - 13	627 HS	611 LS	
	900 Bonneville Speedmaster	05 - 15	627 HS*	611 LS	
	900 Bonneville Spirit	15 - 15	627 HS	611 LS	
	900 Bonneville Street Cup	17 - 18	627 HS	611 LS	
	900 Bonneville T100	05 - 20	627 HS	611 LS	
	900 Bonneville T100	21 - 23	671 HS	611 LS	
	900 Bonneville T100 Black	16 - 20	627 HS	611 LS	
	900 Bonneville T214	15 - 15	627 HS	611 LS	
	900 Daytona	91 - 93	624 HS*	633 LS	
	900 Daytona	94 - 98	624 HS*	638 LS	
	900 Daytona Super III	94 - 98	683 HS*	633 LS	
	900 Daytona, Sprint Left	93 - 93	611 HS	611 LS	
	900 Daytona, Sprint Right	93 - 93	638 HS		
	900 Legend TT	99 - 01	627 HS	700 LS	
	900 Rally Pro	20 - 23	901 HS*	675 LS	
	900 Scrambler	06 - 16	627 HS	611 LS	
	900 Scrambler	23 - 23	762 HS	611 LS	
	900 Speed Triple	94 - 96	624 HS*	638 LS	
	900 Speed Twin	23 - 23	762 HS	611 LS	
	900 Sprint	94 - 98	624 HS*	638 LS	
	900 Street Cup	17 - 20	627 HS	611 LS	
	900 Street Scrambler	17 - 18	627 HS	611 LS	
	900 Street Scrambler	19 - 22	762 HS	611 LS	
	900 Street Twin	16 - 18	627 HS	611 LS	
	900 Street Twin	19 - 22	762 HS	611 LS	
	900 T100 Bud Ekins	20 - 20	627 HS	611 LS	
	900 Thruxton	04 - 05	627 HS	611 LS	
	900 Thruxton Ace	15 - 15	627 HS	611 LS	
	900 Thunderbird	96 - 05	627 HS	700 LS	
	900 Thunderbird Sport	03 - 04	627 HS*	700 LS	
	900 Tiger Left	93 - 98	611 HS	611 LS	
	900 Tiger Right	93 - 98	638 HS		
	900 Tiger	99 - 00	627 HS*	700 LS	
	900 Tiger	20 - 23	901 HS*	675 LS	
	900 Tiger GT	20 - 23	901 HS*	675 LS	
	900 Tiger GT Low	20 - 23	901 HS*	675 LS	
	900 Tiger GT Pro	20 - 23	901 HS*	675 LS	
	900 Tiger Rally	20 - 23	901 HS*	675 LS	
	900 Trident Left	91 - 98	611 HS	611 LS	
	900 Trident Right	91 - 98	638 HS		
	900 Trophy Left	91 - 95	611 HS	611 LS	
	900 Trophy Right	91 - 95	638 HS		
	900 Trophy	96 - 03	624 HS*	633 LS	
T509	900 Speed Triple	97 - 01	624 HS*	611 LS	
T595	950 Daytona	96 - 98	624 HS*	611 LS	
	955 Daytona Centennial	02 - 04	624 HS*	611 LS	
	955 Daytona from VIN 132513	99 - 01	624 HS*	614 LS	
	955 Daytona to VIN 132512	99 - 06	624 HS*	611 LS	

\* = 2 sets required / 2 jeux pour l'Avant.

Full compound selection, see under "Brake pad 1:1 Drawings" / Sélection complète de composés, voir "1:1 Schémas Plaquettes de frein".

**RECOMMENDED**

1xx - 2xx = Scooter Pads  
 5xx - 9xx = Street, Off Road & Racing Pads  
 2xxx = Brake Shoes



TRIUMPH				
955 Speed Triple	99 - 06	624 HS*	611 LS	
955 Sprint RS	00 - 05	624 HS*	611 LS	
955 Sprint ST	99 - 04	624 HS*	611 LS	
955 Tiger	01 - 03	627 HS*	627 LS	
955 Tiger	04 - 06	627 HS*	638 LS	
1000 Daytona	92 - 92	624 HS*	633 LS	
1000 Trophy Left	91 - 95	611 HS	611 LS	
1000 Trophy Right	91 - 95	638 HS		
1050 Speed 94	15 - 16	762 HS*	611 LS	
1050 Speed 94R	15 - 16	901 HS*	611 LS	
1050 Speed Triple	05 - 07	782 HS*	611 LS	
1050 Speed Triple	08 - 15	762 HS*	611 LS	
1050 Speed Triple	16 - 17	901 HS*	611 LS	
1050 Speed Triple R	12 - 18	901 HS*	611 LS	
1050 Speed Triple RS	16 - 20	901 HS*	611 LS	
1050 Speed Triple S	16 - 20	901 HS*	611 LS	
1050 Sprint GT ABS	10 - 15	624 HS*	611 LS	
1050 Sprint GT SE ABS	10 - 15	624 HS*	611 LS	
1050 Sprint ST	05 - 11	624 HS*	611 LS	
1050 Tiger	07 - 13	782 HS*	638 LS	
1050 Tiger SE	09 - 13	782 HS*	638 LS	
1050 Tiger Sport	15 - 19	782 HS*	611 LS	
1200 Bonneville Bobber	17 - 20	627 HS	614 LS	
1200 Bonneville Bobber	21 - 23	671 HS*	614 LS	
1200 Bonneville Bobber Black	18 - 23	671 HS*	614 LS	
1200 Bonneville Speedmaster	18 - 23	671 HS*	614 LS	
1200 Bonneville T120	16 - 20	627 HS	611 LS	
1200 Bonneville T120	21 - 23	671 HS*	611 LS	
1200 Bonneville T120 Ace	19 - 20	627 HS	611 LS	
1200 Bonneville T120 Black	16 - 20	627 HS	611 LS	
1200 Bonneville T120 Black	21 - 23	671 HS*	611 LS	
1200 Bonneville T120 Diamond Ed.	19 - 20	627 HS	611 LS	
1200 Daytona	91 - 97	624 HS*	633 LS	
1200 Scrambler X	24 - 24	627 HS*	674 LS	
1200 Scrambler XC	19 - 23	901 HS*	674 LS	
1200 Scrambler XE	19 - 24	901 HS*	674 LS	
1200 Speed Triple RR	22 - 22	901 HS*	730 LS	
1200 Speed Triple RS	21 - 23	901 HS*	730 LS	
1200 Speed Twin	19 - 20	762 HS*	611 LS	
1200 Speed Twin	21 - 23	901 HS*	611 LS	
1200 T120 Bud Ekins	20 - 20	627 HS	611 LS	
1200 Thruxton	16 - 19	627 HS*	611 LS	
1200 Thruxton R	16 - 19	901 HS*	611 LS	
1200 Thruxton RS	20 - 23	901 HS*	611 LS	
1200 Tiger Explorer	12 - 15	624 HS*	611 LS	
1200 Tiger Explorer	16 - 17	900 HS*	611 LS	
1200 Tiger GT	22 - 23	901 HS*	675 LS	
1200 Tiger GT Explorer	22 - 23	901 HS*	675 LS	
1200 Tiger GT Pro	22 - 23	901 HS*	675 LS	
1200 Tiger Rally Explorer	22 - 23	901 HS*	675 LS	
1200 Tiger Rally Pro	22 - 23	901 HS*	675 LS	
1200 Tiger XCA	18 - 20	900 HS*	611 LS	
1200 Tiger XCX	18 - 20	900 HS*	611 LS	
1200 Tiger XR	18 - 19	900 HS*	611 LS	
1200 Tiger XRT	18 - 20	900 HS*	611 LS	
1200 Tiger XRX	18 - 20	900 HS*	611 LS	
1200 Tiger XRX Low	18 - 20	900 HS*	611 LS	
1200 Trophy Left	91 - 95	611 HS	611 LS	
1200 Trophy Right	91 - 95	638 HS		
1200 Trophy	96 - 03	624 HS*	633 LS	
1200 Trophy SE	13 - 18	740 HS*	611 LS	
1600 Thunderbird	09 - 18	624 HS*	674 LS	
1700 Thunderbird Commander	14 - 18	624 HS*	674 LS	
1700 Thunderbird LT	14 - 18	624 HS*	674 LS	
1700 Thunderbird Nightstorm	14 - 18	624 HS*	674 LS	
1700 Thunderbird Storm	11 - 18	624 HS*	674 LS	
2300 Rocket 3 Classic	07 - 13	624 HS*	674 LS	
2300 Rocket 3 Roadster	10 - 18	624 HS*	674 LS	
2300 Rocket 3 Touring	13 - 14	624 HS*	674 LS	
2300 Rocket III	04 - 13	624 HS*	674 LS	
2300 Rocket X	15 - 15	624 HS*	674 LS	
2500 Rocket 3 GT	19 - 23	841 HS*	900 HS	

**RECOMMENDED**

1xx - 2xx = Scooter Pads  
 5xx - 9xx = Street, Off Road & Racing Pads  
 2xxx = Brake Shoes



TRIUMPH				
2500 Rocket 3 R	19 - 23	841 HS*	900 HS	
<b>TRS</b>				
125 ONE	19 - 20	963 RSI	803 RSI	
125 RR ONE	19 - 20	963 RSI	803 RSI	
250 ONE	16 - 19	802 RSI	803 RSI	
250 RR ONE	19 - 20	963 RSI	803 RSI	
280 ONE	16 - 19	802 RSI	803 RSI	
280 RR ONE	19 - 20	963 RSI	803 RSI	
300 ONE	16 - 19	802 RSI	803 RSI	
300 RR ONE	19 - 20	963 RSI	803 RSI	
<b>UVM</b>				
50 BeThere	99 - 99	101 HF		
50 Bingo	99 - 99	101 HF		
125 BeThere	99 - 99	101 CT		
125 Bingo	99 - 99	101 CT		
125 Paragon	99 - 99	101 CT		
<b>VELOCIFERO</b>				
50 Velocifero	94 - 94	2189	2181	
<b>VERTEMATI</b>				
C 500 Cross	02 - 04	671 RSI	675 RSI	
E 501 Enduro	02 - 04	671 SI	675 SI	
S 501 Supermotard	02 - 04	671 HF	675 HF	
<b>VERTIGO</b>				
300 Combat Camo Works	15 - 19	939 RSI	803 RSI	
300 Combat Ice Hell	15 - 19	939 RSI	803 RSI	
300 Combat RR	15 - 19	939 RSI	803 RSI	
<b>VICTORY</b>				
Empulse TT	16 - 17	706 H.HS*	730 LS	
1200 Octane	17 - 17	674 H.HS	675 H.LS	
1500 Kingpin	04 - 05	706 H.HS	674 H.LS	
1500 Touring Cruiser	03 - 06	706 H.HS*	674 H.LS	
1500 V92C Cruiser	98 - 02	706 H.HS	674 H.LS	
1500 V92C Deluxe	01 - 02	706 H.HS	674 H.LS	
1500 V92SC Sport Cruiser	00 - 02	706 H.HS*	674 H.LS	
1500 Vegas	03 - 05	706 H.HS	674 H.LS	
1500 Vegas 8-Ball	05 - 05	706 H.HS	674 H.LS	
1634 Hammer	05 - 07	706 H.HS	674 H.LS	
1634 Hammer	08 - 08	782 H.HS*	700 H.LS	
1634 Hammer S	06 - 08	706 H.HS	674 H.LS	
1634 Kingpin	06 - 07	706 H.HS	674 H.LS	
1634 Kingpin all models	08 - 12	782 H.HS	700 H.LS	
1634 Kingpin Tour	06 - 07	706 H.HS	674 H.LS	
1634 Vegas	06 - 07	706 H.HS	674 H.LS	
1634 Vegas	08 - 17	782 H.HS	700 H.LS	
1634 Vegas 8-Ball	06 - 07	706 H.HS	674 H.LS	
1634 Vegas 8-Ball	08 - 17	782 H.HS	700 H.LS	
1634 Vegas Jackpot	06 - 07	706 H.HS	674 H.LS	
1634 Vegas Jackpot	08 - 08	782 H.HS	700 H.LS	
1731 Boardwalk	13 - 15	782 H.HS	700 H.LS	
1731 Cross Country	10 - 17	782 H.HS*	700 H.LS	
1731 Cross Country 8-Ball	14 - 16	782 H.HS*	700 H.LS	
1731 Cross Country Tour	12 - 17	782 H.HS*	700 H.LS	
1731 Cross Roads	10 - 12	782 H.HS*	700 H.LS	
1731 Cross Roads 8-Ball	14 - 14	782 H.HS*	700 H.LS	
1731 Cross Roads Classic	14 - 14	782 H.HS*	700 H.LS	
1731 Gunner	15 - 17	782 H.HS	700 H.LS	
1731 Hammer	09 - 11	782 H.HS*	700 H.LS	
1731 Hammer 8-Ball	10 - 16	782 H.HS*	700 H.LS	
1731 Hammer S	09 - 17	782 H.HS*	700 H.LS	
1731 Hard-Ball	12 - 13	782 H.HS*	700 H.LS	
1731 High-Ball	12 - 17	782 H.HS	700 H.LS	
1731 Jackpot	10 - 16	782 H.HS	700 H.LS	
1731 Judge	13 - 17	782 H.HS	700 H.LS	
1731 Kingpin	10 - 12	782 H.HS	700 H.LS	
1731 Kingpin 8-Ball	10 - 11	782 H.HS	700 H.LS	
1731 Magnum	15 - 17	782 H.HS*	700 H.LS	

\* = 2 sets required / 2 jeux pour l'Avant.

Full compound selection, see under "Brake pad 1:1 Drawings" / Sélection complète de composants, voir "1:1 Schémas Plaquettes de frein".



**RECOMMENDED**

1xx - 2xx = Scooter Pads  
5xx - 9xx = Street, Off Road & Racing Pads  
2xxx = Brake Shoes



**VICTORY**

1731	Magnum X-1	15 - 17	782 H.HS*	700 H.LS
1731	Vegas	10 - 17	782 H.HS	700 H.LS
1731	Vegas 8-Ball	10 - 17	782 H.HS	700 H.LS
1731	Vegas Jackpot	09 - 09	782 H.HS	700 H.LS
1731	Vision all models	08 - 17	735 H.HS*	700 H.LS

**VOGE**

125	Brivido R	24 - 24	638 HS	915 HF
350	Trofeo AC	24 - 24	638 HS	915 HF
500	R	23 - 23	627 HS*	657 LS
AC	500	23 - 23	627 HS*	657 LS
ACX	500	23 - 23	700 HS*	657 LS
DS	500	23 - 23	627 HS*	657 LS
DSX	500	23 - 23	627 HS*	657 LS
	525 Brivido R	24 - 24	627 HS*	657 LS
	525 Brivido RR	24 - 24	900 HS	657 LS
	525 CU	24 - 24	706 HS	675 LS
	525 Trofeo ACX	24 - 24	627 HS*	657 LS
	525 Valico DSX	24 - 24	627 HS*	657 LS
DSX	650	23 - 23	627 HS*	657 LS
	900 DSX	24 - 24	674 HS*	675 LS
DS	900 Valico	23 - 23	674 HS*	675 LS

**VOR**

400	Cross	00 - 01	671 RSI	675 RSI
400	Enduro	00 - 01	671 SI	675 SI
EN	400	02 - 03	671 SI	675 SI
MX	400	02 - 02	671 RSI	675 RSI
SM	400	02 - 02	566 RSI	675 RSI
EN	450	02 - 04	671 SI	675 SI
MX	450	02 - 04	671 RSI	675 RSI
SM	450	02 - 04	566 RSI	675 RSI
	500 492 Enduro	99 - 99	671 SI	675 SI
	500 492 Super Motard	00 - 01	566 HF	675 HF
	500 495 Cross	99 - 99	671 RSI	675 RSI
EN	530	02 - 04	671 SI	675 SI
MX	530	02 - 04	671 RSI	675 RSI
SM	530	02 - 04	566 RSI	675 RSI

**VOXAN**

1000	Cafe Racer	01 - 06	566 HS*	730 LS
1000	Roadster	01 - 06	566 HS*	730 LS
1000	Scrambler	01 - 03	627 HF*	633 HF
VB1	1000 EVO	04 - 06	706 HS*	730 LS

**WRM**

450	MX	06 - 08	671 RSI	791 RSI
-----	----	---------	---------	---------

**XINGFU**

XF	150 A	97 - 97	572 HF	
----	-------	---------	--------	--

**YAMAHA**

NEO'S		23 - 23	226 HF	
	50 AJP Caliper incl. pin/spring	91 - 19	188 HF	
	50 Axis Pro Foot	92 - 99	111 HF	2012
	50 Beluga	88 - 89	2021	2021
	50 Beluga	90 - 92	2050	2050
	50 Cygnus	96 - 01	107 HF	
	50 Jog R/RR	02 - 18	123 HF	
	50 Neo's 4	09 - 19	123 HF	
	50 Slider	00 - 05	145 HF	
	50 Why	99 - 07	123 HF	2050
BW	50	91 - 94	2050	2050
BW	50	03 - 05	111 HF	
BW	50 Bump	97 - 02	123 HF	2050
BW	50 Next Generation	96 - 07	123 HF	2050
BW	50 Sports Spec R	02 - 06	123 HF	
BW	50 Spy	95 - 03	123 HF	2050
CA	50 Riva Salient	83 - 86	2112	2021
CG	50 A, B Riva Jog	90 - 91	2112	2021
CR	50 Target	91 - 95	111 HF	2028
CR	50 Z	91 - 95	111 HF	2050



**RECOMMENDED**

1xx - 2xx = Scooter Pads  
5xx - 9xx = Street, Off Road & Racing Pads  
2xxx = Brake Shoes



**YAMAHA**

CV	50 A/R Jog	03 - 08	206 HF	
CV	50 Jog, Jog ZR	01 - 06	165 HF	
CW	50 TA Zuma	90 - 90	2050	2050
CX	50	88 - 93	2028	2028
CY	50 F Jog	94 - 94	2021	2028
DT	50 LCD	98 - 01	136 HF	2028
DT	50 M, MX	78 - 86	2032	2032
DT	50 MX	87 - 90	2050	2050
DT	50 R	89 - 97	107 HF	2050
DT	50 R	98 - 03	109 HF	2028
DT	50 R	04 - 08	105 HF	167 HF
DT	50 X Supermotard	04 - 08	168 HF	167 HF
FS	50 DX	75 - 79	500 HF	2032
FS1	50 DX	77 - 78	500 HF	2032
FS1	50 DX	79 - 81	531 HF	2032
FS1	50 E	74 - 76	2032	2032
FS1	50 SE	81 - 82	2032	2032
FZR	50	90 - 91	638 HF	570 HF
FZR	50	92 - 92	611 HF	632 HF
JOG	50 (Spain)	88 - 88	111 HF	2021
JOG	50 CY	90 - 92	2021	2050
JOG	50 E	88 - 90	2112	2021
JOG	50 R	02 - 07	111 HF	2050
JOG-Z	50	88 - 89	619 HF	2182
JOG-Z	50	90 - 91	114 HF	2021
LB	50 Chappy	80 - 83	2032	2032
LC	50 M, Bop, G,H Champ	80 - 81	2021	2021
MA	50 M, QT 50	80 - 86	2112	2112
MJ	50 J,M Towny	82 - 82	2112	2112
MJ	50 M Towny	81 - 93	2112	2112
MS	50	85 - 86	2112	2021
NS	50 Aerox	13 - 19	114 HF	145 HF
PW	50	80 - 24	2112	2112
QA	50 Pocke	83 - 85	2112	2112
QB	50 Vogel	83 - 85	2112	2112
QT	50 Yamahopper	79 - 87	2112	2112
RD	50	76 - 78	500 HF	2032
RD	50 M	79 - 80	531 HF	2032
RD	50 MX	81 - 87	547 HF	2032
RS	50 Champ	88 - 93	111 HF	2021
RX	50 K	83 - 85	547 HF	2032
SA	50 M, ME Passola	80 - 84	2112	2021
SG	50 Sting	84 - 91	2021	2021
SH	50 E, F Razz	93 - 95	2112	2021
SH	50 Mint	93 - 96	2112	2021
SH	50 T,EMT,U,MU,W,MW,A,MA,B, D,MD	87 - 93	2112	2021
T	50	86 - 89	2050	2050
TDR	50	90 - 92	107 HF	107 HF
TRAFIC	50 M	83 - 83	2050	2050
TT-R	50	06 - 22	2010	2010
TY	50 , M	77 - 80	2032	2032
TZM	50 R	94 - 97	134 HF	107 HF
TZR	50	90 - 92	134 HF	107 HF
TZR	50	93 - 02	134 HF	137 HF
TZR	50	03 - 04	168 HF	105 HF
V	50 M	83 - 83	2050	2050
V	50 M, P	74 - 82	2032	2032
YA	50 Axis Mofa	97 - 02	123 HF	2050
YE	50 Zest (Italy)	92 - 95	114 HF	2028
YE	50 Zest (Japan)	92 - 95	111 HF	2021
YFM	50 Raptor	04 - 11	2028*	2034
YH	50	98 - 07	114 HF	
YM	50 Breeze, Fizz	95 - 95	114 HF	2050
YN	50 Neo's, LC	97 - 16	123 HF	2050
YQ	50 Aerox	97 - 12	114 HF	145 HF
YSR	50	87 - 91	575 HF	2028
YSR	50	92 - 92	575 HF	2032
YZ	50	80 - 83	2182	2182
RD	60	73 - 75	2032	2032
YF	60 S Moto 4	86 - 86		2050
YT	60 Tri Zinger	84 - 85		2050

\* = 2 sets required / 2 jeux pour l'Avant.

Full compound selection, see under "Brake pad 1:1 Drawings" / Sélection complète de composés, voir "1:1 Schémas Plaquettes de frein".

**RECOMMENDED**1xx - 2xx = Scooter Pads  
5xx - 9xx = Street, Off Road & Racing Pads  
2xxx = Brake Shoes

YAMAHA					
YZ	60	85 - 85	2182	2182	
YZ	65	19 - 24	589 RSI	592 RSI	
V	76 A	76 - 76	2032	2032	
V	75 A	77 - 77	2032	2032	
	80 Beluga	81 - 89	2028	2028	
BW	80	86 - 90	2182	2182	
CH	80 Beluga (CH 80)	90 - 90	2050	2021	
CJ	80	86 - 88	2182	2182	
CV	80 Riva	83 - 87	2028	2028	
CW	80 Beluga	81 - 83	2028	2028	
DT	80 LC	81 - 84	550 HF	2034	
DT	80 LC-2	85 - 92	575 HF	2034	
DT	80 MX	81 - 83	2032	2032	
DT	80 MX, MXS	84 - 85	2050	2050	
LB2	80 Bop 2	80 - 80	2032	2032	
PW	80	83 - 85	2182	2050	
PW	80	91 - 08	2182	2028	
RD	80 LC	81 - 82	550 HF	2032	
RD	80 LC	83 - 85	575 HF	2032	
RD	80 MX	81 - 86	547 HF	2032	
RX	80 SE	82 - 84	547 HF	2032	
T	80 Townmate	83 - 97	2050	2050	
TDR	80	89 - 89	575 HF	575 HF	
TY	80	77 - 82	2182	2032	
TY	80	83 - 84	2182	2028	
TZR	80	89 - 91	570 HF	2034	
TZR	80	92 - 95	619 HF	575 HF	
V	80	79 - 82	2032	2032	
V	80 DL	83 - 83	2050	2050	
VN	80 NW	88 - 88	2034	2034	
YD	80	89 - 89	611 HF	632 HF	
YE	80 Zest (Italy)	93 - 94	114 HF		
YE	80 Zest (Japan)	93 - 95	111 HF	2021	
YFM	80	87 - 88	2050*	2034	
YFM	80	92 - 94	2028*	2034	
YFM	80 Badger	95 - 07	2028*	2034	
YFM	80 Grizzly	05 - 08	2028*	2034	
YFM	80 Raptor	02 - 08	2028*	2034	
YSR	80	86 - 92	575 HF	2028	
YZ	80	74 - 79	2182	2032	
YZ	80	80 - 85	2182	2182	
YZ	80	86 - 92	589 SI	2182	
YZ	80	93 - 01	589 RSI	592 RSI	
YZ	85	02 - 24	589 RSI	592 RSI	
	90 Axis Pro Foot	94 - 94	111 HF		
CR	90 Target	91 - 94	111 HF	2028	
JOG	90	90 - 91	111 HF	2021	
RD	90	76 - 79	500 HF		
TT-R	90	00 - 10	2182	2028	
V	90	78 - 78	2032	2032	
YA	90 Axis	90 - 93	111 HF	2032	
YFM	90 RY Raptor	09 - 15	2028*	586 SI	
	100 Aerox	00 - 06	123 HF	2034	
	100 Neo's	00 - 02	123 HF	2034	
AG	100 Farmbike	80 - 91	2032	2034	
AG	100 Farmbike	92 - 93	2050	2034	
DT	100	76 - 80	2032	2034	
RD	100	80 - 82	531 HF		
RD	100 D	76 - 79	500 HF		
RS	100	75 - 80	2032	2032	
RS	100 DX	77 - 79	500 HF	2028	
RS	100 DX	80 - 82	531 HF	2028	
RT	100 A-H	90 - 96	2028	2028	
RX	100	76 - 79	500 HF	2032	
RX	100	84 - 87	550 HF	2032	
RXS	100	83 - 97	2050	2050	
YB	100	78 - 81	2032	2032	
YB	100	82 - 86	2032	2028	
YB	100	87 - 92	2028	2028	
YW	100 Booster	99 - 02	111 HF		
YZ	100	78 - 81	2032	2034	
YZ	100	82 - 83	2028	2034	

**RECOMMENDED**1xx - 2xx = Scooter Pads  
5xx - 9xx = Street, Off Road & Racing Pads  
2xxx = Brake Shoes

YAMAHA					
	105 Crypton	98 - 04	107 HF	2050	
	110 Mio	05 - 07	165 HF		
	110 Mio Sporty	05 - 07	165 HF		
	110 Nouvo	06 - 07	165 HF		
TT-R	110	08 - 24	2182	2028	
	115 D'elight	14 - 20	227 HF		
RX	115 S	82 - 85	550 HF	2032	
	125 D'elight	17 - 22	226 CT		
	125 Xenter	12 - 18	208 CT	2209	
BL	125 Beluga	85 - 87	2034	2034	
BL	125 Beluga	88 - 93	2115	2034	
BWs	125	10 - 11	208 CT	2209	
DT	125 E, MX, LC	74 - 85	2034	2034	
DT	125 LC	85 - 87	575 HF	2034	
DT	125 MX	90 - 93	2034	2034	
DT	125 R	96 - 07	107 CT	107 CT	
DT	125 R, Electric	88 - 03	575 HF	575 HF	
DT	125 Tenere	89 - 90	608 HF	2034	
DT	125 Tenere Scout	90 - 94	653 HF	635 HF	
DT	125 X Supermotard	05 - 08	674 HF	632 HF	
DTZ	125 Tenere	90 - 94	653 HF	635 HF	
GPD	125 N-Max	15 - 19	226 CT	227 CT	
IT	125 G, H, J	80 - 82	2032	2034	
MT	125	14 - 19	844 HF	810 HF	
MT	125	20 - 24	844 HF	632 HF	
MW	125 Tricity Left	14 - 19	222 CT	225 CT	
MW	125 Tricity Right	14 - 19	223 CT		
NXC	125 Cygnus	10 - 11	207 CT	2209	
NXC	125 Cygnus X	05 - 09	190 CT	2209	
RD	125 DX	75 - 77	500 HF	2034	
RD	125 DX	78 - 81	531 HF	2037	
RD	125 LC	82 - 84	550 HF*	2034	
RD	125 LC	85 - 87	570 HF	2034	
RS	125 DX	76 - 79	500 HF	2034	
RS	125 DX	80 - 86	531 HF	2034	
SR	125	92 - 96	550 HF	2050	
SR	125	97 - 02	691 HF	2050	
SR	125 Flame	96 - 96	575 HF		
SR	125 SE	82 - 82	2034	2028	
SX	125 R	88 - 88	536 HF		
TDR	125 (Italy)	90 - 93	608 SI	692 SI	
TDR	125 R	93 - 03	691 HS	575 LS	
TT-R	125	00 - 13	2028	2028	
TT-R	125 LW	00 - 24	589 SI	2028	
TW	125	99 - 07	728 HF	2028	
TY	125	80 - 82	2032	2034	
TZ	125	97 - 00	624 DC	659 RQ	
TZR	125	87 - 88	570 HF	2034	
TZR	125	89 - 92	555 HF	570 HF	
TZR	125	93 - 93	691 HF	555 HF	
TZR	125	94 - 94	634 HF	555 HF	
TZR	125 R	94 - 04	634 HF	570 HF	
VP	125 X-City	08 - 13	181 CT	157 CT	
WR	125	91 - 97	611 SI	632 SI	
WR	125	98 - 02	694 SI	604 SI	
WR	125 R, XY	09 - 16	627 HF	675 HF	
XC	125 Beluga	85 - 85	2034	2034	
XC	125 Beluga, Riva	87 - 92	2115	2034	
XC	125 Cygnus F	00 - 08	107 CT	2034	
XC	125 E, F Riva	93 - 95	2115	2034	
XC	125 F	00 - 08	107 CT	2034	
XC	125 TR Cygnus, R	96 - 98	107 CT	2034	
XC	125 Vity	08 - 13	858 HF		
XN	125 Teos	01 - 04	123 CT	2199	
XQ	125 Maxter	01 - 05	151 CT*	157 CT	
XSR	125	22 - 24	858 HF	632 HF	
XT	125	82 - 86	2034	2028	
XT	125 R	05 - 13	774 HF	773 HF	
XT	125 X Supermotard	05 - 13	774 HF	773 HF	
XTZ	125	05 - 20	611 HF		
XV	125 Virago	97 - 00	691 HF	2034	
XVS	125 Drag Star	00 - 06	691 HF	2199	

\* = 2 sets required / 2 jeux pour l'Avant.

Full compound selection, see under "Brake pad 1:1 Drawings" / Sélection complète de composés, voir "1:1 Schémas Plaquettes de frein".





**RECOMMENDED**

1xx - 2xx = Scooter Pads  
 5xx - 9xx = Street, Off Road & Racing Pads  
 2xxx = Brake Shoes



YAMAHA				
Y	125 Fair Breeze	92 - 95	2050	
YBR	125	06 - 07	575 HF	2034
YBR	125	08 - 16	858 HF	2199
YFA	125 1 G-M Breeze	95 - 07	2028*	2034
YFM	125 Grizzly	04 - 13	2028*	2034
YP	125	89 - 89	2037	2034
YP	125 Majesty	01 - 11	151 CT	157 CT
YP	125 R Majesty	99 - 00	151 CT	2199
YP	125 RA XMAX ABS	17 - 19	229 CT	230 CT
YP	125 XMAX	06 - 09	194 CT	157 CT
YP	125 XMAX	10 - 23	181 CT	157 CT
YP	125 XMAX ABS	11 - 16	181 CT	155 CT
YP	125 XMAX Business ABS	11 - 13	181 CT	155 CT
YP	125 XMAX Sport Ed.	11 - 13	181 CT	157 CT
YS	125	17 - 19	858 HF	
YT	125 Tri Moto	80 - 81		617 HF
YT	125 Tri Moto	82 - 85		576 HF
YW	125 Z	10 - 11	208 CT	2209
YZ	125	74 - 75	2032	2034
YZ	125	76 - 82	2033	2034
YZ	125	83 - 83	2033	2049
YZ	125	84 - 84	2036	2049
YZ	125	85 - 87	580 SI	2049
YZ	125	88 - 88	580 RSI	575 RSI
YZ	125	89 - 89	611 RSI	584 RSI
YZ	125	90 - 95	611 RSI	632 RSI
YZ	125	96 - 97	611 RSI	648 RSI
YZ	125	98 - 02	694 RSI	604 RSI
YZ	125	03 - 07	694 RSI	790 RSI
YZ	125	08 - 21	840 RSI	790 RSI
YZ	125	22 - 24	965 RSI	790 RSI
YZF	125 R	08 - 13	671 HF	810 HF
YZF	125 R	14 - 18	844 HF	810 HF
YZF	125 R	19 - 24	844 HF	632 HF
	135 Crypton X	08 - 14	858 HF	2034
	150 Teos	02 - 05	123 CT	2199
	150 Xenter	12 - 18	208 CT	2209
FZH	150 Fazer	11 - 14	671 HF	
XC	150 Fly One	92 - 99	575 HF	2012
XC	150 Fly One R	98 - 02	107 CT	2028
XQ	150 Maxter	01 - 02	151 CT*	157 CT
YP	150 Majesty	01 - 02	151 CT	157 CT
YZF	150 R15	14 - 14	858 HF	784 HF
GPD	155 N-Max	15 - 19	226 CT	227 CT
MT-15	155	18 - 21	671 HS	632 HF
YZF	155 R	19 - 21	671 HS	632 HF
DT	175	95 - 99	2034	2034
DT	175	00 - 00	728 HF	2034
DT	175 all models	74 - 83	2034	2034
IT	175	80 - 82	2033	2034
TY	175	77 - 80	2032	2034
YT	175 Tri Moto	82 - 83		576 HF
RT	180	90 - 93	596 HF	2034
RT	180	95 - 96	575 SI	2034
XC	180 Cygnus, Riva	83 - 85	2115	2037
YP	180 R Majesty	03 - 03	151 CT	2199
YP	180 R Majesty	04 - 06	151 CT	157 CT
SR	185 Exiter, H, J	81 - 82	2034	2028
BW	200	85 - 88	2028	2028
DT	200	85 - 87	575 HF	2034
DT	200	89 - 89	575 HF	575 HF
DT	200 WR	91 - 93	611 HF	632 HF
IT	200	84 - 84	2049	2049
IT	200	85 - 85	575 SI	2049
IT	200	86 - 86	580 HF	2049
RD	200 A, B	74 - 75	2113	2037
RD	200 DX	76 - 77	500 HF	2037
RD	200 DX	78 - 81	531 HF	2037
RS	200	79 - 79	2037	2037
SDR	200	88 - 89	570 HF	570 HF
SX	200 R	88 - 98	536 HF	
TT	200	86 - 89	575 HF	2028



**RECOMMENDED**

1xx - 2xx = Scooter Pads  
 5xx - 9xx = Street, Off Road & Racing Pads  
 2xxx = Brake Shoes



YAMAHA				
TW	200	87 - 00	2034	2028
TW	200	01 - 22	728 HF	2028
WR	200	91 - 92	611 SI	632 SI
XC	200 Riva	87 - 91	2115	2034
XT	200	85 - 95	2034	2028
YDS-7	200	73 - 75	2113	2064
YFM	200 DXS-DXW Moto 4	86 - 87	2028*	576 HF
YFM	200 N Moto 4	85 - 89	2028*	576 HF
YFS	200 R Blaster	03 - 06	536 SI*	592 SI
YFS	200 U-P Blaster	88 - 02		637 SI
YTM	200 K-N Tri Moto	83 - 85		576 HF
	225 Bronco, Cellow	97 - 02	728 HF	
	225 Serow	85 - 87	575 HF	2014
TT	225 S,T	86 - 00	575 HF	2028
TT-R	225	01 - 04	575 SI	2028
XT	225	92 - 00	575 HF	2028
XT	225	01 - 01	728 HF	2028
XT	225 Serow	86 - 86	575 HF	2028
YFM	225 Moto 4	86 - 88	2028*	576 HF
YTM	225 DRN, DRS Tri Moto	85 - 86		576 HF
YTM	225 DXK, DXN Tri Moto	83 - 85		576 HF
TT-R	230	05 - 22	611 SI	2034
XV	240 Virago	92 - 98	550 HF	
DT	250 all models	75 - 80	2035	2037
FZ	250 Phazer N, S	85 - 86	555 HF*	2034
FZ	250 R	85 - 85	570 HF	
FZ25	250	19 - 19	671 HF	632 HF
FZR	250	87 - 88	590 HF*	570 HF
FZR	250 R	89 - 99	639 HF*	570 HF
FZX	250 Zeal	91 - 92	663 HS	570 LS
GX	250 Left	80 - 85	545 HF	
GX	250 Right	80 - 85	528 HF	
IT	250	80 - 82	2033	2037
IT	250	84 - 84	2036	2037
IT	250	85 - 86	575 SI	2037
MT-25	250	16 - 17	931 HS	932 HF
NX	250	88 - 88	580 HF	
R1-Z	250	90 - 92	639 HF	570 HF
RD	250	73 - 76	504 HF	2064
RD	250	77 - 77	504 HF	504 HF
RD	250	78 - 79	528 HF	528 HF
RD	250 DX Left	80 - 80	545 HF	2064
RD	250 DX Right	80 - 80	528 HF	
RD	250 LC	80 - 80	535 HF	2064
RD	250 LC	81 - 82	547 HF	2064
RD	250 LC	83 - 84	550 HF	555 HF
RZ	250 RR	88 - 88	570 HS*	570 LS
RZR	250	90 - 90	570 HS*	570 LS
SR	250	90 - 93	2192	2034
SR	250 SE	80 - 82	2035	2034
SRV	250	92 - 97	663 HS	
SRX	250	84 - 90	570 HF	2034
SRX	250 T, TC	87 - 87	570 HF	2037
TDR	250	88 - 92	590 HF	570 HF
TT	250	87 - 92	580 HF	2034
TT	250	93 - 03	611 SI	632 SI
TY	250	77 - 78	2032	2034
TY	250	81 - 81	2033	2037
TY	250	84 - 90	2049	2032
TY	250 R	91 - 92	559 HF	2032
TY	250 Z	93 - 96	559 HF	559 HF
TY	250 Z (Scottish)	96 - 96	575 RSI	632 RSI
TZ	250	82 - 85	504 HF	
TZ	250	90 - 05	624 DC*	659 RQ
TZR	250	87 - 88	590 HF*	570 HF
TZR	250	89 - 92	634 HF*	570 HF
TZR	250 R	94 - 94	566 HF*	659 HF
VP	250 X-City	07 - 09	181 MS	155 MS
WR	250	90 - 97	611 SI	632 SI
WR	250	98 - 02	694 SI	604 SI
WR	250 F	01 - 02	694 SI	604 SI
WR	250 F	03 - 13	694 SI	790 SI

\* = 2 sets required / 2 jeux pour l'Avant.

Full compound selection, see under "Brake pad 1:1 Drawings" / Sélection complète de composés, voir "1:1 Schémas Plaquettes de frein".





**RECOMMENDED**

1xx - 2xx = Scooter Pads  
 5xx - 9xx = Street, Off Road & Racing Pads  
 2xxx = Brake Shoes



YAMAHA					
IT	425	80 - 80	2033	2035	
WR	426 F	01 - 02	694 SI	604 SI	
YZ	426 F	00 - 02	694 RSI	604 RSI	
WR	450 F	03 - 15	694 SI	790 SI	
WR	450 F	16 - 20	840 SI	790 SI	
WR	450 F	21 - 24	965 SI	790 SI	
YFM	450 FA Kodiak	03 - 07	536 SI*	754 SI	
YFM	450 Wolverine	06 - 10	536 SI*	754 SI	
YFZ	450 S Left	04 - 05	638 SI	592 SI	
YFZ	450 S Right	04 - 05	611 SI		
YFZ	450 S Left	06 - 09	638 SI	709 SI	
YFZ	450 S Right	06 - 09	611 SI		
YXR	450 Rhino Left	06 - 09	611 SI	816 SI	
YXR	450 Rhino Right	06 - 09	638 SI		
YZ	450 F	03 - 07	694 RSI	790 RSI	
YZ	450 F	08 - 19	840 RSI	790 RSI	
YZ	450 F	20 - 24	965 RSI	790 RSI	
YZ	450 FX	16 - 20	840 SI	790 SI	
YZ	450 FX	21 - 22	965 SI	790 SI	
IT	465	81 - 82	2036	2037	
YZ	465	80 - 80	2036	2035	
YZ	465	81 - 81	2036	2037	
IT	490	84 - 84	2036	2037	
YZ	490	81 - 82	2036	2037	
YZ	490	83 - 83	2036	2034	
YZ	490	84 - 84	2036	2037	
YZ	490	85 - 90	580 SI	2037	
FZR	500 (Austria)	89 - 89	555 HF*	555 HF	
FZR	500 R (Austria)	90 - 91	645 HS*	555 LS	
IT	500 G, H.	80 - 81	2033	2035	
RD	500	83 - 83	555 HF*	555 HF	
RD	500 LC	84 - 85	555 HF*	570 HF	
RZ	500	84 - 86	555 HF*	570 HF	
SR	500	78 - 91	507 HF	2037	
SR	500	92 - 98	2190	2037	
TX	500 A, B	74 - 77	504 HF	2063	
WR	500 B	91 - 91	611 SI	575 SI	
WR	500 ZD, ZE	92 - 93	611 SI	632 SI	
XJ	500 (Austria)	81 - 83	547 HF	2066	
XP	500 TMAX	01 - 03	170 MS	169 MS	
XP	500 TMAX	04 - 07	128 MS*	185 MS	
XP	500 TMAX	08 - 11	198 MS*	185 MS	
XP	500 TMAX Tech Max	11 - 11	198 MS*	185 MS	
XS	500	75 - 76	504 HF*	2063	
XS	500	77 - 81	507 HF	507 HF	
XS	500 DOHC	82 - 82	550 HF		
XT	500	76 - 80	2035	2037	
XT	500	86 - 89	575 HF	2037	
XT	500 (Austria)	83 - 83	550 HF	2037	
XT	500 E (Austria)	90 - 96	650 HS	575 LS	
XV	500 K, Virago	83 - 83	550 HF	2063	
XV	500 SE	83 - 83	550 HF	2063	
XP	530 TMAX	12 - 19	198 MS*	169 MS	
XP	530 TMAX DX	17 - 19	198 MS*	169 MS	
XP	530 TMAX Iron Max	15 - 19	198 MS*	169 MS	
XP	530 TMAX SX	17 - 19	198 MS*	169 MS	
XV	535 DX Virago	98 - 03	663 HS	2065	
XV	535 S Virago	96 - 03	663 HS	2065	
XV	535 Virago	87 - 94	616 HF	2065	
XV	535 Virago	95 - 97	663 HS	2065	
XJ	550 Maxim	81 - 83	547 HF	2063	
XJ	550 Seca	81 - 83	547 HF	2066	
XT	550	82 - 83	2037	2037	
XZ	550	82 - 82	547 HF*	2063	
XZ	550	83 - 84	550 HF*	2063	
XZ	550 RJ, RK	82 - 83	550 HF	2063	
XZ	550 S	83 - 84	550 HF*	2063	
YFM	550 FGPW Grizzly Left	09 - 16	850 SI	852 SI	
YFM	550 FGPW Grizzly Right	09 - 16	849 SI	851 SI	
	560 TMAX	20 - 20	198 MS*	169 MS	
	560 TMAX Tech Max	20 - 20	198 MS*	169 MS	
DT	600 N	85 - 85	575 HF	2034	



**RECOMMENDED**

1xx - 2xx = Scooter Pads  
 5xx - 9xx = Street, Off Road & Racing Pads  
 2xxx = Brake Shoes



YAMAHA					
FJ	600	84 - 85	555 HF*	555 HF	
FZ	600	86 - 87	555 HF*	555 HF	
FZ	600 S, SC	86 - 89	555 HF*	570 HF	
FZ6	600	04 - 08	691 HS*	657 LS	
FZ6	600 Fazer	04 - 08	691 HS*	657 LS	
FZ6	600 Fazer S2	07 - 09	634 HS*	657 LS	
FZ6	600 Fazer S2 ABS	07 - 09	634 HS*	657 LS	
FZ6	600 S2	07 - 09	634 HS*	657 LS	
FZ6	600 S2 ABS	07 - 09	634 HS*	657 LS	
FZ6R	600	09 - 14	691 HS*	614 LS	
FZR	600	89 - 89	555 HF*	555 HF	
FZR	600 R	90 - 91	645 HS*	555 LS	
FZR	600 R	92 - 95	665 HS*	555 LS	
FZS	600 Fazer	98 - 03	634 HS*	570 LS	
FZS	600 S Fazer	01 - 03	634 HS*	570 LS	
SRX	600	86 - 87	570 HF*	570 HF	
SRX	600	88 - 89	590 HF	570 HF	
SRX	600	90 - 99	613 HS	570 LS	
TT	600	85 - 88	575 HF	2034	
TT	600	89 - 89	596 HF	2034	
TT	600	90 - 92	580 HF	2034	
TT	600 E,S	96 - 01	671 HF	675 HF	
TT	600 K,L	83 - 84	2036	2034	
TT	600 R	93 - 95	671 HF	632 HF	
TT	600 R	98 - 07	671 HF	675 HF	
XJ	600	83 - 91	555 HF*	555 HF	
XJ	600 N	91 - 97	663 HS	570 LS	
XJ	600 N	98 - 03	691 HS*	570 LS	
XJ	600 S Diversion	91 - 97	663 HS	570 LS	
XJ	600 S Diversion	98 - 03	691 HS*	570 LS	
XJ6	600 Diversion	09 - 15	691 HS*	614 LS	
XJ6-F	600	09 - 12	691 HS*	614 LS	
XJ6-F	600	13 - 15	691 HS*	657 LS	
XJ6-N	600	09 - 12	691 HS*	614 LS	
XJ6-N	600	13 - 15	691 HS*	657 LS	
XJ6-S	600	09 - 12	691 HS*	614 LS	
XJ6-S	600	13 - 15	691 HS*	657 LS	
XT	600	83 - 86	550 HF	2037	
XT	600 E	90 - 03	650 HS	575 LS	
XT	600 K	91 - 94	650 HS	575 LS	
XT	600 Tenere	83 - 84	550 HF	2037	
XT	600 Z	86 - 88	596 HF	2037	
XT	600 Z, Tenere	87 - 90	596 HF	575 HF	
YFM	600 4x4 Grizzly	98 - 01	592 SI*	2066	
YX	600 Radian	87 - 90	555 HF*	2063	
YZF	600 R Thunder Cat	96 - 03	634 HS*	555 LS	
YZF	600 R6	99 - 02	634 HS*	728 LS	
YZF	600 R6	03 - 16	634 HS*	657 LS	
YZF	600 R6	17 - 24	634 HS*	834 LS	
TX	650	72 - 73	504 HF		
XJ	650	80 - 82	507 HF*	2065	
XJ	650	83 - 83	550 HF	2065	
XJ	650 G, H, SH Left	80 - 83	545 HF	2065	
XJ	650 G, H, SH Right	80 - 83	528 HF		
XJ	650 RJ Seca	81 - 83	507 HF*	2065	
XJ	650 Turbo	81 - 82	550 HF*	2065	
XS	650	75 - 77	504 HF*	2064	
XS	650	77 - 79		2064	
XS	650	78 - 85	507 HF*	507 HF	
XS	650	80 - 82	545 HF	507 HF	
XS	650 SE	80 - 82	507 HF	507 HF	
XS	650 SJ, SK	82 - 82	507 HF*	2064	
XS	650 SK, Heritage	83 - 83	507 HF*	507 HF	
XVS	650 A Drag Star Classic	98 - 06	663 HS	2065	
XVS	650 Drag Star	97 - 06	663 HS	2065	
	660 Rhino Left	05 - 08	611 SI	816 SI	
	660 Rhino Right	05 - 08	638 SI		
MT-03	660	06 - 13	691 HS*	675 LS	
SZR	660	96 - 01	566 HF	519 HF	
XT	660 R	04 - 11	674 HS	675 LS	
XT	660 X	04 - 13	706 HS	675 LS	
XT	660 Z Tenere	08 - 15	671 HS*	675 LS	

\* = 2 sets required / 2 jeux pour l'Avant.

Full compound selection, see under "Brake pad 1:1 Drawings" / Sélection complète de composés, voir "1:1 Schémas Plaquettes de frein".

**RECOMMENDED**1xx - 2xx = Scooter Pads  
5xx - 9xx = Street, Off Road & Racing Pads  
2xxx = Brake Shoes

YAMAHA					
XT	660 Z Tenere ABS	11	- 15	671 HS*	675 LS
XTZ	660 Tenere	91	- 98	650 HS	575 LS
YFM	660 FWP 4x4 Grizzly	02	- 08	592 SI*	799 SI
YFM	660 RN Raptor	01	- 09	592 SI*	592 SI
	700 Tracer 7	21	- 24	634 HS*	657 LS
	700 Tracer 7 GT	21	- 24	634 HS*	657 LS
FZ	700	87	- 88	555 HF*	555 HF
FZX	700 Fazer	87	- 88	555 HF	555 HF
MT-07	700	14	- 24	634 HS*	657 LS
MT-07	700 Moto Cage	15	- 17	634 HS*	657 LS
MT-07	700 SP	18	- 18	634 HS*	657 LS
MT-07	700 Tracer	16	- 20	634 HS*	657 LS
MT-07	700 Tracer GT	19	- 19	634 HS*	657 LS
XJ	700	86	- 89	555 HF	2065
XJ	700 Maxim	85	- 89	555 HF	555 HF
XSR	700	16	- 24	634 HS*	657 LS
XSR	700 XTribute	19	- 22	634 HS*	657 LS
XTZ	700 Tenere	19	- 24	671 HS*	675 LS
XTZ	700 Tenere Explore	19	- 24	671 HS*	675 LS
XTZ	700 Tenere Extreme	19	- 24	671 HS*	675 LS
XTZ	700 Tenere World Raid	19	- 24	671 HS*	675 LS
XTZ	700 Tenere World Rally	19	- 24	671 HS*	675 LS
XV	700 L, LC	84	- 87	555 HF*	2065
XV	700 Virago	87	- 87	555 HF	2065
YFM	700 FGPW Grizzly Left	07	- 17	850 SI	852 SI
YFM	700 FGPW Grizzly Right	07	- 17	849 SI	851 SI
YFM	700 R Raptor Left	06	- 08	611 SI	816 SI
YFM	700 R Raptor Right	06	- 08	638 SI	
YFM	700 Raptor Left	09	- 12	611 SI	816 SI
YFM	700 Raptor Right	09	- 12	638 SI	
YFM	700 Raptor Left	13	- 14	611 SI	709 SI
YFM	700 Raptor Right	13	- 14	638 SI	
YXC	700 Viking VI Left	15	- 16	971 PSI	973 PSI
YXC	700 Viking VI Right	15	- 16	972 PSI	974 PSI
YXC	700 Viking VI EPS Left	15	- 21	971 PSI	973 PSI
YXC	700 Viking VI EPS Right	15	- 21	972 PSI	974 PSI
YXC	700 Viking VI EPS Special Edition Left	16	- 17	971 PSI	973 PSI
YXC	700 Viking VI EPS Special Edition Right	16	- 17	972 PSI	974 PSI
YXE	700 Wolverine Left	16	- 18	971 PSI	973 PSI
YXE	700 Wolverine Right	16	- 18	972 PSI	974 PSI
YXE	700 Wolverine EPS Left	17	- 17	971 PSI	973 PSI
YXE	700 Wolverine EPS Right	17	- 17	972 PSI	974 PSI
YXE	700 Wolverine R-Spec Left	16	- 16	971 PSI	973 PSI
YXE	700 Wolverine R-Spec Right	16	- 16	972 PSI	974 PSI
YXE	700 Wolverine R-Spec EPS Left	16	- 18	971 PSI	973 PSI
YXE	700 Wolverine R-Spec EPS Right	16	- 18	972 PSI	974 PSI
YXE	700 Wolverine R-Spec EPS SE Left	16	- 16	971 PSI	973 PSI
YXE	700 Wolverine R-Spec EPS SE Right	16	- 16	972 PSI	974 PSI
YXE	700 Wolverine R-Spec EPS Special Edition Left	17	- 17	971 PSI	973 PSI
YXE	700 Wolverine R-Spec EPS Special Edition Right	17	- 17	972 PSI	974 PSI
YXM	700 Viking Left	14	- 20	971 PSI	973 PSI
YXM	700 Viking Right	14	- 20	972 PSI	974 PSI
YXM	700 Viking EPS Left	14	- 21	971 PSI	973 PSI
YXM	700 Viking EPS Right	14	- 21	972 PSI	974 PSI
YXM	700 Viking EPS SE Left	14	- 17	971 PSI	973 PSI
YXM	700 Viking EPS SE Right	14	- 17	972 PSI	974 PSI
YXM	700 Viking EPS Special E Left	19	- 19	971 PSI	973 PSI
YXM	700 Viking EPS Special E Right	19	- 19	972 PSI	974 PSI
YXM	700 Viking EPS Special Edition Left	16	- 16	971 PSI	973 PSI
YXM	700 Viking EPS Special Edition Right	16	- 16	972 PSI	974 PSI
YXR	700 Rhino Left	08	- 14	638 SI	638 SI
YXR	700 Rhino Right	08	- 14	611 SI	611 SI
YZF	700 R7	22	- 24	634 HS*	657 LS
	750 Maxim	81	- 81	547 HF	555 HF
FZ	750	85	- 86	555 HF*	555 HF
FZ	750 Genesis	86	- 86	555 HF*	570 HF

**RECOMMENDED**1xx - 2xx = Scooter Pads  
5xx - 9xx = Street, Off Road & Racing Pads  
2xxx = Brake Shoes

YAMAHA					
FZ	750 Genesis	87	- 88	555 HF*	555 HF
FZ	750 Genesis	89	- 92	590 HS*	555 LS
FZR	750 R	89	- 92	624 HS*	555 LS
FZR	750 R Genesis	87	- 88	613 HF*	555 HF
FZX	750 Fazer	86	- 90	555 HF*	555 HF
TX	750	73	- 74	504 HF*	2065
TX	750 A	73	- 76	504 HF*	555 HF
VF	750 Virago	88	- 88	555 HF	2065
XJ	750	83	- 87	555 HF*	555 HF
XJ	750 E	81	- 83	507 HF	2065
XJ	750 Maxim	82	- 82	550 HF*	2065
XJ	750 Seca	81	- 83	547 HF*	2065
XS	750	77	- 80	507 HF*	507 HF
XS	750 H, J, K	81	- 82	545 HF	507 HF
XS	750 SE Left	79	- 80	545 HF	507 HF
XS	750 SE Right	79	- 80	528 HF	
XTZ	750 Super Tenere Left	89	- 95	611 HF	633 HF
XTZ	750 Super Tenere Right	89	- 95	638 HF	
XV	750	89	- 92	555 HS	2065
XV	750 MK	83	- 83	528 HF	2063
XV	750 SE	81	- 83	545 HF	2063
YZF	750 R, SP	93	- 97	683 HS*	555 LS
YZF	750 R7 OW02	99	- 02	634 HS*	733 LS
YZF	750 R7 OW02 Race kit	99	- 01	729 HS*	
	800 Fazer 8	10	- 15	634 HS*	657 LS
FZ8	800	10	- 14	634 HS*	657 LS
MXT	850 Niken	18	- 24	634 HS*	991 LS
MXT	850 Niken GT	19	- 24	634 HS*	991 LS
TDM	850	91	- 95	590 HS*	555 LS
TDM	850	96	- 01	645 HS*	555 LS
TRX	850	95	- 00	613 HS*	555 LS
TRX	850 (Italy)	95	- 99	706 HS*	555 LS
XS	850	80	- 80	507 HF*	507 HF
XS	850 Left	81	- 81	545 HF	507 HF
XS	850 Right	81	- 81	528 HF	
YXE	850 Wolverine X2 Left	19	- 19	971 PSI	973 PSI
YXE	850 Wolverine X2 Right	19	- 19	972 PSI	974 PSI
YXE	850 Wolverine X2 EPS Left	20	- 20	971 PSI	973 PSI
YXE	850 Wolverine X2 EPS Right	20	- 20	972 PSI	974 PSI
YXE	850 Wolverine X2 R-Spec Left	19	- 20	971 PSI	973 PSI
YXE	850 Wolverine X2 R-Spec Right	19	- 20	972 PSI	974 PSI
YXE	850 Wolverine X2 XTR Left	20	- 20	971 PSI	973 PSI
YXE	850 Wolverine X2 XTR Right	20	- 20	972 PSI	974 PSI
YXF	850 Wolverine X4 Left	18	- 20	971 PSI	973 PSI
YXF	850 Wolverine X4 Right	18	- 20	972 PSI	974 PSI
YXF	850 Wolverine X4 SE Left	19	- 19	971 PSI	973 PSI
YXF	850 Wolverine X4 SE Right	19	- 19	972 PSI	974 PSI
YXF	850 Wolverine X4 Special Left	19	- 19	971 PSI	973 PSI
YXF	850 Wolverine X4 Special Right	19	- 19	972 PSI	974 PSI
YXF	850 Wolverine X4 Special Edition Left	18	- 18	971 PSI	973 PSI
YXF	850 Wolverine X4 Special Edition Right	18	- 18	972 PSI	974 PSI
YXF	850 Wolverine X4 XTR Left	20	- 20	971 PSI	973 PSI
YXF	850 Wolverine X4 XTR Right	20	- 20	972 PSI	974 PSI
	900 Tracer 9	15	- 24	634 HS*	657 LS
	900 Tracer 9 GT	18	- 24	634 HS*	657 LS
MT-09	900	14	- 24	634 HS*	657 LS
MT-09	900 SP	18	- 23	634 HS*	657 LS
MT-09	900 SP	24	- 24	841 HS*	657 LS
MT-09	900 Sport Tracker	15	- 16	634 HS*	657 LS
MT-09	900 Street Rally	14	- 16	634 HS*	657 LS
TDM	900	02	- 14	634 HS*	769 LS
XJ	900	83	- 93	555 HF*	555 HF
XJ	900 F	85	- 93	555 HF*	555 HF
XJ	900 S, Diversion	94	- 03	663 HS*	555 LS
XSR	900	16	- 24	634 HS*	657 LS
XSR	900 Abarth	17	- 22	634 HS*	657 LS
XSR	900 GP	24	- 24	634 HS*	657 LS
XV	920	81	- 82	507 HF	
XV	920 J	82	- 82	547 HF	2065
XV	920 K, MK, Virago	83	- 83	545 HF	550 HF

\* = 2 sets required / 2 jeux pour l'Avant.

Full compound selection, see under "Brake pad 1:1 Drawings" / Sélection complète de composants, voir "1:1 Schémas Plaquettes de frein".





**RECOMMENDED**

1xx - 2xx = Scooter Pads  
 5xx - 9xx = Street, Off Road & Racing Pads  
 2xxx = Brake Shoes



**YAMAHA**

XV	920 Virago	81 - 81	547 HF*	555 HF
SCR	950 Scrambler	17 - 19	663 HS	769 LS
XV	950 Bolt	14 - 18	663 HS	769 LS
XV	950 Bolt C-Spec	15 - 18	663 HS	769 LS
XV	950 Bolt Racer	17 - 18	663 HS	769 LS
XV	950 Bolt R-Spec	14 - 21		769 LS
XV	950 Bolt R-Spec	14 - 22	663 HS	
XV	950 R	19 - 20	663 HS	769 LS
XVS	950 A Midnight Star	09 - 13	663 HS	769 LS
	1000 Wolverine RMAX 4	21 - 21	979 PSI*	980 PSI*
	1000 Wolverine RMAX 4 LE	21 - 21	979 PSI*	980 PSI*
	1000 Wolverine RMAX 4 SE	21 - 21	979 PSI*	980 PSI*
FJ	1000 L, LC	84 - 84	555 HF	555 HF
FZ1	1000 Fazer	06 - 16	634 HS*	657 LS
FZR	1000	94 - 95	683 HS*	555 LS
FZR	1000 EX UP	90 - 91	645 HS*	555 LS
FZR	1000 EX UP	92 - 93	665 HS*	555 LS
FZR	1000 Genesis	87 - 89	613 HF*	555 HF
FZS	1000 Fazer	01 - 05	634 HS*	770 LS
GTS	1000	93 - 99	682 HF	555 HF
MT-10	1000	16 - 24	634 HS*	657 LS
MT-10	1000 SP	17 - 24	634 HS*	657 LS
MT-10	1000 Tourer Ed.	17 - 19	634 HS*	657 LS
XV	1000 L, C	84 - 85	555 HF*	555 HF
XV	1000 SE	83 - 85	547 HF*	2065
XV	1000 TR1	81 - 88	507 HF*	2065
XV	1000 Virago	86 - 88	555 HF*	2065
YXE	1000	21 - 21	979 PSI*	980 PSI*
YZX	1000 EPS	16 - 20	979 PSI*	980 PSI*
YZX	1000 EPS SE	17 - 19	979 PSI*	980 PSI*
YZX	1000 EPS Special	20 - 20	979 PSI*	980 PSI*
YZX	1000 EPS Special Edition	16 - 17	979 PSI*	980 PSI*
YZX	1000 EPS SS	17 - 20	979 PSI*	980 PSI*
YZX	1000 SS Special	20 - 20	979 PSI*	980 PSI*
YZX	1000 SS XTR	20 - 20	979 PSI*	980 PSI*
YZF	1000 R Thunder Ace	96 - 99	634 HS*	555 LS
YZF	1000 R1	98 - 01	634 HS*	733 LS
YZF	1000 R1	02 - 03	634 HS*	728 LS
YZF	1000 R1	04 - 06	634 HS*	657 LS
YZF	1000 R1	15 - 24	634 HS*	834 LS
YZF	1000 R1 (4-pad)	07 - 14	839 HS*	657 LS
YZF	1000 R1 (4-pad) ABS	12 - 14	839 HS*	657 LS
YZF	1000 R1 SP	06 - 06	634 HS*	657 LS
YZF	1000 R1M	15 - 24	634 HS*	834 LS
YZF	1000 R1S	16 - 16	634 HS*	834 LS
	1100 SE, Maxim	81 - 81	547 HF	
BT	1100 Bulldog	02 - 06	634 HS*	555 LS
FJ	1100	83 - 85	555 HF*	555 HF
XJ	1100	81 - 81	547 HF*	528 HF
XS	1100 E,F,G,H	78 - 81	507 HF*	507 HF
XS	1100 LH Midnight	81 - 81	547 HF*	528 HF
XS	1100 SF, SG, SH, LG Left	79 - 81	545 HF	507 HF
XS	1100 SF, SG, SH, LG Right	79 - 81	528 HF	
XV	1100 Virago	86 - 93	555 HF*	2065
XV	1100 Virago	94 - 98	663 HS*	2065
XV	1100 Virago	99 - 99	691 HS*	555 LS
XVS	1100 A Drag Star Classic	00 - 06	691 HS*	555 LS
XVS	1100 Drag Star	99 - 06	691 HS*	555 LS
FJ	1200	86 - 87	555 HF*	555 HF
FJ	1200	88 - 90	613 HF*	555 HF
FJ	1200 ABS	91 - 93	613 HS*	555 LS
V-MAX	1200	85 - 89	555 HF*	555 HF
V-MAX	1200	90 - 92	555 HS*	555 LS
V-MAX	1200	93 - 03	645 HS*	555 LS
XJR	1200	94 - 98	613 HS*	555 LS
XJR	1200 (Italy)	95 - 98	706 HS*	555 LS
XJR	1200 SP	97 - 98	613 HS*	555 LS
XT	1200 Z Super Tenere	14 - 19	634 HS*	769 LS
XT	1200 ZE Super Tenere	14 - 19	634 HS*	769 LS
XT	1200 ZE Super Tenere Raid Ed.	18 - 19	634 HS*	769 LS
XTZ	1200 Super Tenere	10 - 13	634 HS*	769 LS
XV	1200	84 - 87	555 HF*	555 HF



**RECOMMENDED**

1xx - 2xx = Scooter Pads  
 5xx - 9xx = Street, Off Road & Racing Pads  
 2xxx = Brake Shoes



**YAMAHA**

XV	1200 Venture Royale	85 - 85	555 HF*	555 HF
XV	1200 Z12T	84 - 87	555 HF*	555 HF
XVT	1200 T, Vent. Royale	84 - 85	555 HF*	555 HF
FJR	1300	01 - 03	634 HS*	769 LS
FJR	1300 A	13 - 20	740 HS*	769 LS
FJR	1300 ABS	03 - 05	634 HS*	769 LS
FJR	1300 ABS	06 - 12	740 HS*	769 LS
FJR	1300 AE	16 - 19	740 HS*	769 LS
FJR	1300 AS	13 - 19	740 HS*	769 LS
XJR	1300	99 - 01	634 HS*	555 LS
XJR	1300	02 - 18	634 HS*	770 LS
XJR	1300 Racer	15 - 19	634 HS*	770 LS
XJR	1300 SP	01 - 01	634 HS*	555 LS
XVS	1300 A Midnight Star	07 - 11	691 HS*	769 LS
XVS	1300 Custom	14 - 16	691 HS	769 LS
XVS	1300 Stryker	11 - 14	663 HS	769 LS
XVZ	1300 A Royal Star	96 - 07	613 HS*	590 LS
XVZ	1300 AT Royal Star Tour Classic	97 - 07	613 HS*	590 LS
XVZ	1300 Royal Star Boulevard	99 - 01	613 HS*	590 LS
XVZ	1300 TF Royal Star Venture	99 - 01	663 HS*	590 LS
XVZ	1300 Venture Royale	86 - 89	613 HF*	590 HF
XVZ	1300 Venture Royale	90 - 95	613 HS*	590 LS
XV	1600 A Wild Star	99 - 07	663 HS*	590 LS
MT-01	1700	05 - 06	634 HS*	654 LS
MT-01	1700	07 - 16	839 HS*	654 LS
VMX	1700 V-Max	09 - 18	839 HS*	769 LS
XV	1700 PC Road Star Warrior	03 - 07	634 HS*	769 LS
XV	1700 Road Star Warrior	02 - 02	634 HS*	590 LS
XV	1900 A	11 - 11	740 HS*	769 LS
XV	1900 A Midnight Star	06 - 10	634 HS*	769 LS

**ZANELLA**

	50 Racing Moped	92 - 92	519 HF	
RZA	125	92 - 92	519 HF	
TZ4	125 Patagonia (ARG)	92 - 92	608 HF	

**ZERO**

DS	ZF11.4	13 - 13	694 HS	790 LS
DS	ZF11.4	14 - 14	694 HS	675 LS
DS	ZF12.5	15 - 15	674 HS	675 LS
DS	ZF13.0	16 - 17	674 HS	675 LS
DS	ZF17.3	24 - 24	706 HS*	671 LS
DS	ZF6.0	10 - 12	708 HF	544 HF
DS	ZF8.5	13 - 13	694 HS	790 LS
DS	ZF8.5	14 - 14	694 HS	675 LS
DS	ZF9.0	10 - 12	708 HF	544 HF
DS	ZF9.4	15 - 15	674 HS	675 LS
DS	ZF9.8	16 - 17	674 HS	675 LS
DSR	ZF13.0	16 - 17	674 HS	675 LS
DSR/X	ZF17.3	23 - 23	706 HS*	671 LS
DSRBF	ZF14.4	19 - 21	706 HS	675 LS
FX	ZF2.8	13 - 13	694 HS	790 LS
FX	ZF2.8	14 - 14	694 HS	675 LS
FX	ZF2.8	15 - 15	671 HS	675 LS
FX	ZF3.3	16 - 17	674 HS	675 LS
FX	ZF5.7	13 - 13	694 HS	790 LS
FX	ZF5.7	14 - 14	694 HS	675 LS
FX	ZF5.7	15 - 15	671 HS	675 LS
FX	ZF6.5	16 - 17	674 HS	675 LS
FXE	ZF7.2	21 - 22	674 HS	675 LS
FXS	ZF3.3	16 - 17	674 HS	675 LS
FXS	ZF3.6	16 - 22	674 HS	675 LS
FXS	ZF6.5	16 - 17	674 HS	675 LS
MX		10 - 12	708 HF	544 HF
MX	ZF2.8	13 - 13	694 RSI	790 RSI
MX	ZF5.7	13 - 13	694 RSI	790 RSI
S	ZF11.4	13 - 13	694 HS	790 LS
S	ZF11.4	14 - 14	694 HS	675 LS
S	ZF12.5	15 - 15	674 HS	675 LS
S	ZF13.0	16 - 17	674 HS	675 LS
S	ZF14.4	24 - 24	706 HS*	675 LS
S	ZF6.0	10 - 12	708 HF	544 HF

\* = 2 sets required / 2 jeux pour l'Avant.

Full compound selection, see under "Brake pad 1:1 Drawings" / Sélection complète de composés, voir "1:1 Schémas Plaquettes de frein".



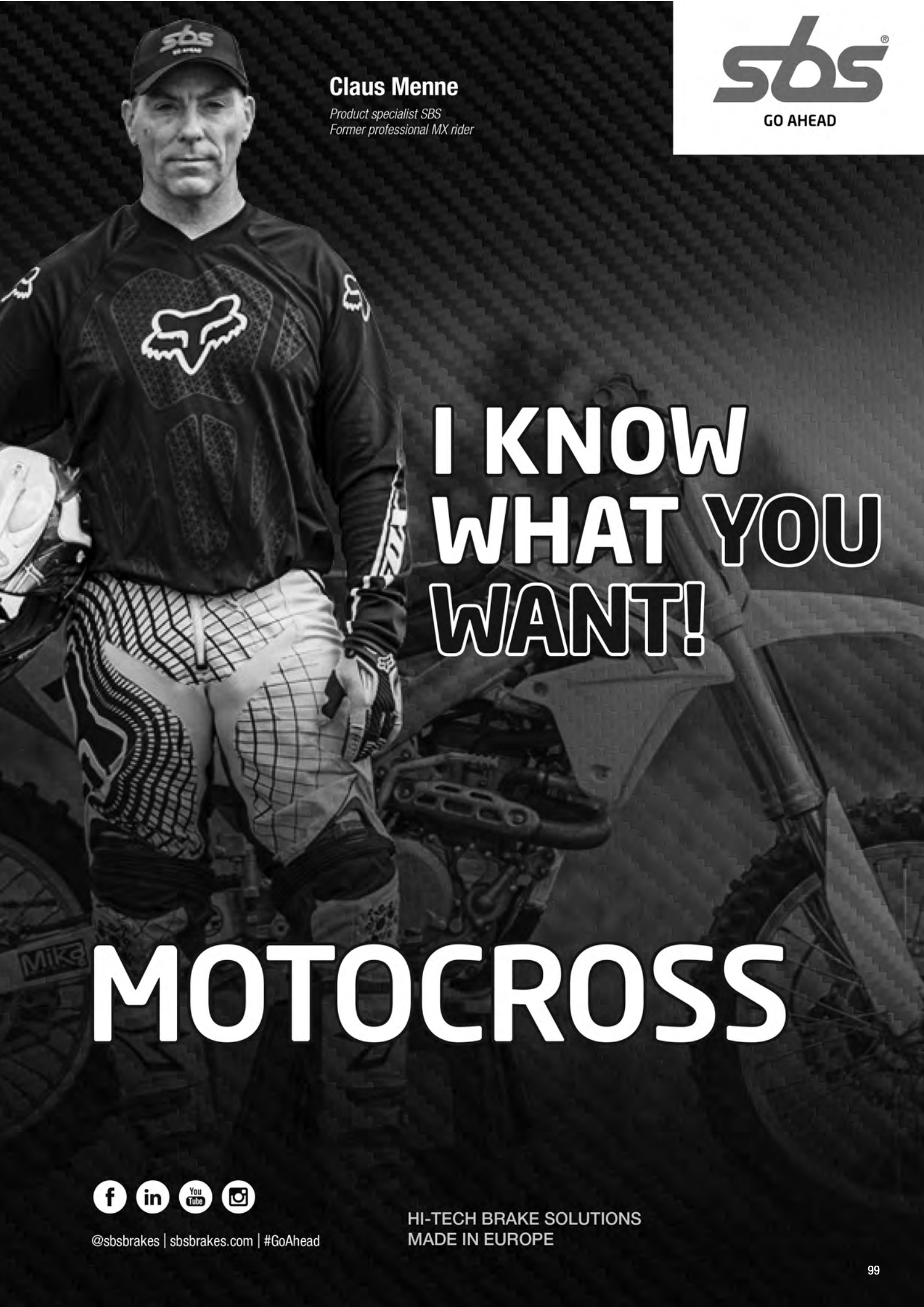

**Claus Menne**

*Product specialist SBS  
Former professional MX rider*

**sbs**<sup>®</sup>

**GO AHEAD**

**I KNOW  
WHAT YOU  
WANT!**

**MOTOCROSS**



@sbsbrakes | sbsbrakes.com | #GoAhead

HI-TECH BRAKE SOLUTIONS  
MADE IN EUROPE



## COMPOUND CHOICE

## COMPOUND CHOICE



BETA			COMPOUND CHOICE			COMPOUND CHOICE			
			RSI	SI	CS	RSI	SI	CS	
450 RX	24 - 24	694	△	△	△	790	△	△	△
<b>FANTIC</b>									
XX 125	20 - 21	840	△	△	△	790	△	△	△
XX 125	22 - 24	965	△	△		790	△	△	△
XX 250	22 - 24	965	△	△		790	△	△	△
XXF 250	22 - 24	965	△	△		790	△	△	△
XXF 450	22 - 24	965	△	△		790	△	△	△
<b>GASGAS</b>									
MC E 5	21 - 24	794	△	△		794	△	△	
MC 50	21 - 24	794	△	△		794	△	△	
MC 65	21 - 22	783	△	△	△	783	△	△	△
MC 65	23 - 24	791	△	△	△	791	△	△	△
MC 85	21 - 24	671	△	△	△	791	△	△	△
MC 125	03 - 13	694	△	△	△	604	△	△	△
MC 125	21 - 24	671	△	△	△	791	△	△	△
MC 250	97 - 99	671	△	△	△	675	△	△	△
MC 250	00 - 13	694	△	△	△	604	△	△	△
MC 250	21 - 24	671	△	△	△	791	△	△	△
MC 250 F	21 - 24	671	△	△	△	791	△	△	△
MC 350 F	22 - 24	671	△	△	△	791	△	△	△
MC 450 F	21 - 24	671	△	△	△	791	△	△	△
<b>HONDA</b>									
CR 80 R, RB	92 - 02	584	△	△		604	△	△	△
CR 85 R, R Expert	03 - 12	592	△	△	△	604	△	△	△
CR 125 R	95 - 01	694	△	△	△	604	△	△	△
CR 125 R	02 - 07	694	△	△	△	777	△	△	△
CR 125 RH, RJ, RK	87 - 94	603	△	△		604	△	△	△
CRF 150 R	07 - 24	592	△	△	△	777	△	△	△
CR 250 R	87 - 94	603	△	△		604	△	△	△
CR 250 R	95 - 01	694	△	△	△	604	△	△	△
CR 250 R	02 - 07	694	△	△	△	777	△	△	△
CRF 250 R	04 - 24	694	△	△	△	777	△	△	△
CRF 450 R	02 - 24	694	△	△	△	777	△	△	△
CRF 450 R-S	22 - 24	694	△	△	△	777	△	△	△
CRF 450 RWE	19 - 24	694	△	△	△	777	△	△	△
CR 500 R	87 - 94	603	△	△		604	△	△	△
CR 500 R	95 - 01	694	△	△	△	604	△	△	△
<b>HUSABERG</b>									
FC 400	99 - 02	671	△	△	△	675	△	△	△
FC 450	03 - 08	671	△	△	△	675	△	△	△
FC 470	01 - 02	671	△	△	△	675	△	△	△
FC 501	99 - 01	671	△	△	△	675	△	△	△
FC 550	01 - 05	671	△	△	△	675	△	△	△
FC 600	99 - 01	671	△	△	△	675	△	△	△
<b>HUSQVARNA</b>									
EE 5	19 - 24	794	△	△		794	△	△	
TC 50	17 - 24	794	△	△		794	△	△	
TC 50 Mini	22 - 24	794	△	△		794	△	△	
CR 65	12 - 13	783	△	△	△	872	△	△	△
TC 65	17 - 22	783	△	△	△	783	△	△	△
TC 65	23 - 24	791	△	△	△	791	△	△	△
TC 85	14 - 20	885	△	△	△	872	△	△	△
TC 85	21 - 24	671	△	△	△	791	△	△	△
CR 125	05 - 13	671	△	△	△	791	△	△	△
TC 125	14 - 24	671	△	△	△	791	△	△	△
CR 250	96 - 04	671	△	△	△	675	△	△	△
CR 250	05 - 05	671	△	△	△	791	△	△	△
FC 250	14 - 24	671	△	△	△	791	△	△	△
TC 250	02 - 03	671	△	△	△	675	△	△	△
TC 250	04 - 24	671	△	△	△	791	△	△	△
TC 300	14 - 15	671	△	△	△	791	△	△	△
FC 350	14 - 24	671	△	△	△	791	△	△	△
TC 449	11 - 13	671	△	△	△	791	△	△	△
FC 450	14 - 24	671	△	△	△	791	△	△	△
TC 450	02 - 03	671	△	△	△	675	△	△	△
TC 450	04 - 10	671	△	△	△	791	△	△	△
TC 510	02 - 03	671	△	△	△	675	△	△	△

△ = Available quality / Qualité disponible.

To select compound for off-road front/rear - see page 23-25 / Pour sélectionner vos plaquettes off-road avant/arrière - voir page 23-25.





## COMPOUND CHOICE

## COMPOUND CHOICE



HUSQVARNA				RSI	SI	CS		RSI	SI	CS
TC	510	04 - 10	671	△	△	△	791	△	△	△
TC	570	01 - 13	671	△	△	△	675	△	△	△
TC	610	96 - 13	671	△	△	△	675	△	△	△
<b>KAWASAKI</b>										
KX	65	00 - 24	752	△	△	△	536	△	△	
KX	80	88 - 96	544	△	△	△	592	△	△	△
KX	80	97 - 00	726	△	△	△	592	△	△	△
KX	85	01 - 24	726	△	△	△	592	△	△	△
KX	85 II	01 - 24	726	△	△	△	592	△	△	△
KX	100	88 - 96	544	△	△	△	592	△	△	△
KX	100	97 - 21	726	△	△	△	592	△	△	△
KX	112	22 - 24	726	△	△	△	592	△	△	△
KX	125	86 - 86	546	△	△		586	△	△	
KX	125	89 - 93	611	△	△		632	△	△	
KX	125	94 - 94	694	△	△	△	632	△	△	
KX	125	95 - 08	694	△	△	△	604	△	△	△
KX	250	86 - 86	546	△	△		586	△	△	
KX	250	89 - 93	611	△	△		632	△	△	
KX	250	94 - 94	694	△	△	△	632	△	△	
KX	250	95 - 08	694	△	△	△	604	△	△	△
KX	250	19 - 24	694	△	△	△	790	△	△	△
KX	250 F	04 - 18	694	△	△	△	790	△	△	△
KX	450	19 - 23	694	△	△	△	790	△	△	△
KX	450	24 - 24	671	△	△	△	790	△	△	△
KX	450 F	06 - 18	694	△	△	△	790	△	△	△
KX	500	86 - 86	546	△	△		586	△	△	
KX	500	89 - 93	611	△	△		632	△	△	
KX	500	94 - 95	694	△	△	△	632	△	△	
KX	500	96 - 04	694	△	△	△	604	△	△	△
<b>KOVE</b>										
MX	250	24 - 24	694	△	△	△	777	△	△	△
MX	450	24 - 24	694	△	△	△	777	△	△	△
<b>KTM</b>										
SX-E	5	19 - 24	794	△	△		794	△	△	
SX	50	09 - 24	794	△	△		794	△	△	
SX	50 Mini	09 - 24	794	△	△		794	△	△	
SX	60	99 - 99	559	△	△	△	-			
SX	65	00 - 01	559	△	△	△	574	△	△	△
SX	65	02 - 03	783	△	△	△	574	△	△	△
SX	65	04 - 08	783	△	△	△	794	△	△	
SX	65	09 - 22	783	△	△	△	783	△	△	△
SX	65	23 - 24	791	△	△	△	791	△	△	△
SX	85 (17/14)	04 - 10	783	△	△	△	783	△	△	△
SX	85 (17/14)	11 - 11	783	△	△	△	872	△	△	△
SX	85 (17/14)	12 - 20	885	△	△	△	872	△	△	△
SX	85 (17/14)	21 - 24	671	△	△	△	791	△	△	△
SX	85 (19/16)	13 - 20	885	△	△	△	872	△	△	△
SX	85 (19/16)	21 - 24	671	△	△	△	791	△	△	△
SX	125	96 - 03	671	△	△	△	675	△	△	△
SX	125	04 - 24	671	△	△	△	791	△	△	△
SXS	125	01 - 02	671	△	△	△	675	△	△	△
SX	144	07 - 08	671	△	△	△	791	△	△	△
SX	150	09 - 23	671	△	△	△	791	△	△	△
SX	200	03 - 04	671	△	△	△	791	△	△	△
SX	250	96 - 02	671	△	△	△	675	△	△	△
SX	250	03 - 24	671	△	△	△	791	△	△	△
SX-F	250	06 - 24	671	△	△	△	791	△	△	△
SX	300	23 - 24	671	△	△	△	791	△	△	△
SX-F	350	11 - 24	671	△	△	△	791	△	△	△
SX	360	96 - 97	671	△	△	△	675	△	△	△
SX	380	98 - 02	671	△	△	△	675	△	△	△
SX	400	00 - 02	671	△	△	△	675	△	△	△
SX-F	450	03 - 24	671	△	△	△	791	△	△	△
SX	505	07 - 09	671	△	△	△	791	△	△	△
SX-F	505	07 - 08	671	△	△	△	791	△	△	△
SX-F	520	00 - 02	671	△	△	△	675	△	△	△
SX-F	525	03 - 03	671	△	△	△	675	△	△	△
SX-F	525	04 - 06	671	△	△	△	791	△	△	△
SXS	540	01 - 02	671	△	△	△	675	△	△	△

Applications  
Motocross

△ = Available quality / Qualité disponible.

To select compound for off-road front/rear - see page 23-25 / Pour sélectionner vos plaquettes off-road avant/arrière - voir page 23-25.



## COMPOUND CHOICE



## COMPOUND CHOICE



			COMPOUND CHOICE				COMPOUND CHOICE			
			RSI	SI	CS					
<b>KTM</b>										
SX	620	95 - 99	671	△	△	△	675	△	△	△
<b>STARK</b>										
	Varg	23 - 24	671	△	△	△	791	△	△	△
<b>SUZUKI</b>										
RM	65	03 - 06	752	△	△	△	536	△	△	
RM	80	96 - 01	702	△	△	△	544	△	△	△
RM	85	02 - 04	702	△	△	△	544	△	△	△
RM	85	05 - 24	726	△	△	△	820	△	△	△
RM	100	03 - 03	726	△	△	△	592	△	△	△
RM	125	88 - 88	611	△	△		584	△	△	
RM	125	89 - 90	611	△	△		632	△	△	
RM	125	91 - 95	611	△	△		648	△	△	
RM	125	96 - 09	694	△	△	△	604	△	△	△
RM	250	87 - 88	611	△	△		584	△	△	
RM	250	89 - 90	611	△	△		632	△	△	
RM	250	91 - 95	611	△	△		648	△	△	
RM	250	96 - 09	694	△	△	△	604	△	△	△
RMX	250	89 - 95	611	△	△		648	△	△	
RMX	250	96 - 98	694	△	△	△	648	△	△	
RM-Z	250	04 - 24	694	△	△	△	790	△	△	△
RM-Z	450	05 - 24	694	△	△	△	790	△	△	△
RM	500	88 - 89	611	△	△		592	△	△	△
<b>TM</b>										
	80 Cross	96 - 00	671	△	△	△	675	△	△	△
	80 Junior	96 - 00	544	△	△	△	592	△	△	△
MX	85	01 - 12	671	△	△	△	604	△	△	△
MX	85	13 - 24	777	△	△	△	777	△	△	△
MX	125	96 - 00	671	△	△	△	675	△	△	△
MX	125	01 - 04	671	△	△	△	604	△	△	△
MX	125	05 - 24	671	△	△	△	790	△	△	△
MX	144	08 - 24	671	△	△	△	790	△	△	△
	250 E	95 - 00	671	△	△	△	675	△	△	△
MX	250	01 - 04	671	△	△	△	604	△	△	△
MX	250	05 - 24	671	△	△	△	790	△	△	△
MX	250 F	01 - 04	671	△	△	△	604	△	△	△
MX	250 F	05 - 24	671	△	△	△	790	△	△	△
MX	300	98 - 00	671	△	△	△	675	△	△	△
MX	300	01 - 04	671	△	△	△	604	△	△	△
MX	300	05 - 24	671	△	△	△	790	△	△	△
	320	96 - 97	671	△	△	△	675	△	△	△
	400 F	00 - 00	671	△	△	△	675	△	△	△
	400 F	01 - 01	671	△	△	△	604	△	△	△
MX	450 F	02 - 04	671	△	△	△	604	△	△	△
MX	450 F	05 - 24	671	△	△	△	790	△	△	△
MX	530 F	01 - 04	671	△	△	△	604	△	△	△
MX	530 F	05 - 24	671	△	△	△	790	△	△	△
<b>TRIUMPH</b>										
TF	250 X	24 - 24	671	△	△	△	791	△	△	△
<b>YAMAHA</b>										
YZ	65	19 - 24	589	△	△	△	592	△	△	△
YZ	80	93 - 01	589	△	△	△	592	△	△	△
YZ	85	02 - 24	589	△	△	△	592	△	△	△
YZ	125	88 - 88	580	△	△		575	△	△	
YZ	125	89 - 89	611	△	△		584	△	△	
YZ	125	90 - 95	611	△	△		632	△	△	
YZ	125	96 - 97	611	△	△		648	△	△	
YZ	125	98 - 02	694	△	△	△	604	△	△	△
YZ	125	03 - 07	694	△	△	△	790	△	△	△
YZ	125	08 - 21	840	△	△	△	790	△	△	△
YZ	125	22 - 24	965	△	△		790	△	△	△
YZ	250	88 - 88	580	△	△		575	△	△	
YZ	250	89 - 89	611	△	△		584	△	△	
YZ	250	98 - 02	694	△	△	△	604	△	△	△
YZ	250	03 - 07	694	△	△	△	790	△	△	△
YZ	250	08 - 21	840	△	△	△	790	△	△	△
YZ	250	22 - 24	965	△	△		790	△	△	△
YZ	250 A	90 - 90	611	△	△		632	△	△	

△ = Available quality / Qualité disponible.

To select compound for off-road front/rear - see page 23-25 / Pour sélectionner vos plaquettes off-road avant/arrière - voir page 23-25.

**COMPOUND CHOICE****COMPOUND CHOICE**

YAMAHA					RSI	SI	CS		RSI	SI	CS
YZ	250 B1-J1	91 - 97	611	△	△			648	△	△	
YZ	250 F	01 - 02	694	△	△	△		604	△	△	△
YZ	250 F	03 - 06	694	△	△	△		790	△	△	△
YZ	250 F	07 - 20	840	△	△	△		790	△	△	△
YZ	250 F	21 - 24	965	△	△			790	△	△	△
YZ	250 WRA,WRB	90 - 91	611	△	△			632	△	△	
YZ	400 F	98 - 98	694	△	△	△		648	△	△	
YZ	400 F	99 - 99	694	△	△	△		604	△	△	△
YZ	426 F	00 - 02	694	△	△	△		604	△	△	△
YZ	450 F	03 - 07	694	△	△	△		790	△	△	△
YZ	450 F	08 - 19	840	△	△	△		790	△	△	△
YZ	450 F	20 - 24	965	△	△			790	△	△	△

Applications  
Motocross

△ = Available quality / Qualité disponible.

To select compound for off-road front/rear - see page 23-25 / Pour sélectionner vos plaquettes off-road avant/arrière - voir page 23-25.

# NEW! Get the brake feel you want!

# sbs<sup>®</sup>

GO AHEAD

Find the right brake pad compound for you and  
your bike with the new Compound Selector at  
[sbsbrakes.com](http://sbsbrakes.com)

Find the right compound for you and  
your bike

Click Start Now, answer 2-3 questions and get the answer right away

START NOW



@sbsbrakes | [sbsbrakes.com](http://sbsbrakes.com)

HI-TECH BRAKE SOLUTIONS  
MADE IN EUROPE





**Allan Østli**

*Racing Manager SBS  
Winner Ducati Challenge*

**sbs**<sup>®</sup>

**GO AHEAD**

**I KNOW  
WHAT YOU  
WANT!**

**ROAD RACING**



@sbsbrakes | sbsbrakes.com | #GoAhead

HI-TECH BRAKE SOLUTIONS  
MADE IN EUROPE



APRILIA				COMPOUND CHOICE				COMPOUND CHOICE		
				DS-1	DS-2	DC	RST		RQ	LS
RS	660	20 - 22	900*	△	△	△	△	730	△	△
RS	660 Extrem	23 - 23	900*	△	△	△	△	730	△	△
RS	660 Trofeo	22 - 22	900*	△	△	△	△	730	△	△
RSV4	1000 ,ABS	09 - 13	841*	△	△	△	△	730	△	△
RSV4	1000 Factory	09 - 11	841*	△	△	△	△	730	△	△
RSV4-R	1000 ,ABS APRC	10 - 10	841*	△	△	△	△	730	△	△
RSV4-RF	1000	15 - 20	901*	△	△	△	△	730	△	△
RSV4-RR	1000	15 - 20	901*	△	△	△	△	730	△	△

BIMOTA				COMPOUND CHOICE				COMPOUND CHOICE		
				DS-1	DS-2	DC	RST		RQ	LS
BB3	1000	14 - 18	901*	△	△	△	△	730	△	△
DB5	1000	05 - 11	762*	△		△	△	730	△	△
DB5	1000 S	07 - 11	762*	△		△	△	730	△	△
DB7	1098	08 - 08	762*	△		△	△	730	△	△
DB7	1099	09 - 09	901*	△	△	△	△	519	△	△
3D	1100 Tesi	07 - 11	762*	△		△	△	730	△	△
DB8	1198	10 - 14	901*	△	△	△	△	730	△	△

BMW				COMPOUND CHOICE				COMPOUND CHOICE		
				DS-1	DS-2	DC	RST		RQ	LS
F	900 R	20 - 24	900*	△	△	△	△	675	△	△
M	1000 RR	21 - 24	985*	△	△	△	△	984	△	△
S	1000 RR (Brembo cal.)	09 - 18	870*	△	△	△	△	675	△	△
S	1000 RR (Hayes cal.)	19 - 21	960*	△	△	△	△	675	△	△
S	1000 RR (Nissin cal.)	21 - 24	985*	△	△	△	△	675	△	△
S	1000 RR HP4	12 - 14	901*	△	△	△	△	675	△	△
	1200 HP2 Sport	08 - 10	901*	△	△	△	△	671	△	△

COLOVE				COMPOUND CHOICE				COMPOUND CHOICE		
				DS-1	DS-2	DC	RST		RQ	LS
	322 321RR	23 - 23	900	△	△	△	△	926		

DUCATI				COMPOUND CHOICE				COMPOUND CHOICE		
				DS-1	DS-2	DC	RST		RQ	LS
	848	08 - 10	706*	△	△	△	△	730	△	△
	848 EVO	11 - 12	841*	△	△	△	△	730	△	△
	899 Panigale	14 - 15	900*	△	△	△	△	730	△	△
	955 Panigale V2	20 - 24	900*	△	△	△	△	730	△	△
	959 Panigale	16 - 20	900*	△	△	△	△	730	△	△
	959 Panigale Corse	18 - 20	900*	△	△	△	△	730	△	△
	996 S	01 - 01	706	△	△	△	△	519	△	△
	998 Superleggera V4	20 - 24	841*	△	△	△	△	730	△	△
	1000 Panigale V4 R	19 - 24	841*	△	△	△	△	730	△	△
	1098 R	08 - 10	841*	△	△	△	△	730	△	△
	1098 R Bayliss LE	09 - 10	841*	△	△	△	△	730	△	△
	1103 Panigale V4	18 - 24	841*	△	△	△	△	730	△	△
	1103 Panigale V4 SP	21 - 21	841*	△	△	△	△	730	△	△
	1103 Panigale V4 Speciale	18 - 19	841*	△	△	△	△	730	△	△
	1103 Panigale V4S	18 - 24	841*	△	△	△	△	730	△	△
	1103 Panigale V4S Corse	19 - 19	841*	△	△	△	△	730	△	△
	1198	09 - 13	841*	△	△	△	△	730	△	△
	1198 S	09 - 12	841*	△	△	△	△	730	△	△
	1198 SP	11 - 12	841*	△	△	△	△	730	△	△
	1199 Panigale	12 - 14	841*	△	△	△	△	730	△	△
	1199 Panigale R	13 - 15	841*	△	△	△	△	730	△	△
	1199 Panigale S	12 - 14	841*	△	△	△	△	730	△	△
	1199 Superleggera	14 - 14	841*	△	△	△	△	730	△	△
	1299 Panigale	15 - 17	841*	△	△	△	△	730	△	△
	1299 Panigale R	15 - 17	841*	△	△	△	△	730	△	△
	1299 Panigale R Final Edition	17 - 20	841*	△	△	△	△	730	△	△
	1299 Panigale S	15 - 17	841*	△	△	△	△	730	△	△
	1299 Panigale S Anniversario	17 - 17	841*	△	△	△	△	730	△	△
	1299 Superleggera	17 - 17	841*	△	△	△	△	730	△	△

EBR				COMPOUND CHOICE				COMPOUND CHOICE		
				DS-1	DS-2	DC	RST		RQ	LS
	1190 RS	12 - 15	856	△			△	857		△

HARLEY DAVIDSON				COMPOUND CHOICE				COMPOUND CHOICE		
				DS-1	DS-2	DC	RST		RQ	LS
	XR 1200	08 - 10	860*	△	△			808		△

HONDA				COMPOUND CHOICE				COMPOUND CHOICE		
				DS-1	DS-2	DC	RST		RQ	LS
	CBR 250 R (Nissin cal)	11 - 13	627			△	△	881	△	△
	CBR 250 RR	17 - 21	700	△	△	△	△	881	△	△
	NSF 250 R	11 - 21	782			△	△	618	△	△
	CBR 500 R	13 - 21	700	△	△	△	△	881	△	△

\* = 2 sets required / 2 jeux pour l'Avant.

△ = Available quality / Qualité disponible.

To select compound for racing front/rear - see page 19-22 / Pour sélectionner vos plaquettes racing avant/arrière - voir page 19-22.



COMPOUND CHOICE

COMPOUND CHOICE



HONDA				DS-1	DS-2	DC	RST		RQ	LS
CBR	500 R	22 - 24	994					881	△	△
CBR	600 RR	18 - 24	947*	△	△	△	△	834	△	△
CBR	650 F	14 - 20	627*					881	△	△
CBR	650 F ABS	14 - 20	700*	△	△	△	△	881	△	△
CBR	1000 RR Fireblade	06 - 16	809*	△	△	△	△	834	△	△
CBR	1000 RR Fireblade	17 - 22	947*	△	△	△	△	834	△	△
CBR	1000 RR SP	14 - 22	901*	△	△	△	△	834	△	△
CBR	1000 RR SP2	17 - 19	901*	△	△	△	△	834	△	△
CBR	1000 RR-R Fireblade	20 - 23	985*	△	△	△	△	730	△	△
CBR	1000 RR-R Fireblade	24 - 24	841*	△	△	△	△	730	△	△
CBR	1000 RR-R SP Fireblade	20 - 21	901*	△	△	△	△	730	△	△
CBR	1000 RR-R SP Fireblade	22 - 24	841*	△	△	△	△	730	△	△
RC213V-S	1000	16 - 18	901*	△	△	△	△	730	△	△
<b>KAWASAKI</b>										
EX	250 R Ninja	18 - 20	955	△	△	△	△	638	△	△
ZX-25R	250	20 - 23	806	△	△	△	△	657	△	△
EX	300 R Ninja, ABS	13 - 17	638	△		△	△	638	△	△
EX	400 Ninja	18 - 23	955*	△	△	△	△	638	△	△
EX	400 Ninja KRT	18 - 18	638*	△		△	△	638	△	△
ZX-4R	400	23 - 24	806*	△	△	△	△	657	△	△
ZX-4R	400 SE	23 - 24	806*	△	△	△	△	657	△	△
ZX-4RR	400	23 - 24	806*	△	△	△	△	657	△	△
ZX-6R	600 Ninja	07 - 17	838*	△	△	△	△	687	△	△
ZX-6RR	600 Ninja	03 - 06	788*	△		△	△	687	△	△
ZX-6R	636 Ninja	13 - 18	894*			△	△	834	△	△
ZX-6R	636 Ninja ABS	13 - 24	894*			△	△	834	△	△
ZX-6R	636 Ninja KRT ABS	13 - 24	894*			△	△	834	△	△
ZX-6R	636 Ninja Upgrade DS	13 - 24	860*	△	△			834	△	△
ZX	1000 H2 Carbon Ninja	17 - 20	841*	△	△	△	△	730	△	△
ZX	1000 H2 Ninja	15 - 21	841*	△	△	△	△	730	△	△
ZX	1000 H2R Ninja	15 - 24	841*	△	△	△	△	730	△	△
ZX-10R	1000 Ninja	08 - 10	806*	△	△	△	△	687	△	△
ZX-10R	1000 Ninja	11 - 15	806*	△	△	△	△	834	△	△
ZX-10R	1000 Ninja	16 - 24	841*	△	△	△	△	834	△	△
ZX-10R	1000 Ninja KRT	16 - 18	841*	△	△	△	△	834	△	△
ZX-10R	1000 Ninja SE	18 - 22	841*	△	△	△	△	834	△	△
ZX-10RR	1000 Ninja	17 - 24	841*	△	△	△	△	834	△	△
<b>KOVE</b>										
	322 321RR	23 - 23	900	△	△	△	△	926		
<b>KTM</b>										
RC	250	14 - 15	877			△	△	675	△	△
RC	250 Upgrade DS	14 - 15	634	△	△	△	△	675	△	△
RC4R	250	20 - 20	706	△	△	△	△	675	△	△
RC	390	14 - 23	877			△	△	675	△	△
RC	390 Upgrade DS	14 - 23	634	△	△	△	△	675	△	△
	690 Duke R	14 - 17	841	△	△	△	△	675	△	△
RC8	890 C	22 - 22	841*	△	△	△	△	730	△	△
RC8	1190	08 - 11	841*	△	△	△	△	730	△	△
RC8	1190 R	09 - 15	841*	△	△	△	△	730	△	△
RC8	1190 R Track	11 - 15	841*	△	△	△	△	730	△	△
<b>MORIWAKI</b>										
MD	250	09 - 09	782			△	△	618	△	
<b>MV AGUSTA</b>										
F3	675	11 - 12	706*	△	△	△	△	763	△	△
F3	675	13 - 14	706*	△	△	△	△	730	△	△
F3	675	15 - 20	901*	△	△	△	△	730	△	△
F3	675 RC	16 - 20	901*	△	△	△	△	730	△	△
F3	800	14 - 20	901*	△	△	△	△	763	△	△
F3	800 RC	16 - 20	901*	△	△	△	△	730	△	△
F3	800 RR	21 - 23	841*	△	△	△	△	730	△	△
F4	1000 LH44	18 - 20	841*	△	△	△	△	763	△	△
F4	1000 R	12 - 19	841*	△	△	△	△	763	△	△
F4	1000 RC	15 - 20	841*	△	△	△	△	763	△	△
F4	1000 RR	12 - 20	841*	△	△	△	△	763	△	△
F4	1078 312 RR	08 - 11	841*	△	△	△	△	763	△	△
F4	1078 CC	08 - 11	841*	△	△	△	△	763	△	△

Applications  
Racing

\* = 2 sets required / 2 jeux pour l'Avant.

△ = Available quality / Qualité disponible.

To select compound for racing front/rear - see page 19-22 / Pour sélectionner vos plaquettes racing avant/arrière - voir page 19-22.



OHVALE			COMPOUND CHOICE				COMPOUND CHOICE			
				DS-1	DS-2	DC	RST		RQ	LS
GP-0	110	17 - 23	885				△	872	△	
GP-0	160	17 - 23	885				△	872	△	
GP-0	190	17 - 23	885				△	872	△	
GP-2	190	21 - 24	962				△	548		
GP-0	212	17 - 19	872*				△	872	△	

SUZUKI			COMPOUND CHOICE				COMPOUND CHOICE			
				DS-1	DS-2	DC	RST		RQ	LS
GSX-R	250	17 - 23	627			△	△	881	△	△
GSX-R	600	06 - 10	806*	△	△	△	△	833	△	△
GSX-R	600	11 - 24	841*	△	△	△	△	834	△	△
SV	650 S ABS	07 - 18	705				△	657	△	△
GSX-R	750	06 - 10	806*	△	△	△	△	833	△	△
GSX-R	750	11 - 23	841*	△	△	△	△	834	△	△
GSX-R	1000	09 - 11	806*	△	△	△	△	834	△	△
GSX-R	1000	12 - 24	841*	△	△	△	△	834	△	△
GSX-R	1000 R	17 - 24	841*	△	△	△	△	834	△	△

TRIUMPH			COMPOUND CHOICE				COMPOUND CHOICE			
				DS-1	DS-2	DC	RST		RQ	LS
675	Daytona R Triple	11 - 12	901*	△	△	△	△	614	△	△
675	Daytona R Triple	13 - 18	901*	△	△	△	△	675	△	△
675	Daytona Triple	09 - 12	864*			△	△	614	△	△
675	Daytona Triple	13 - 18	864*			△	△	675	△	△
765	Daytona Moto2	20 - 22	901*	△	△	△	△	675	△	△

YAMAHA			COMPOUND CHOICE				COMPOUND CHOICE			
				DS-1	DS-2	DC	RST		RQ	LS
YZF	250 R25	15 - 20	931	△	△	△	△	932	△	
YZF	321 R3	15 - 24	931	△	△	△	△	932	△	
YZF	600 R6	03 - 16	634*	△	△	△	△	657	△	△
YZF	600 R6	17 - 24	634*	△	△	△	△	834	△	△
YZF	600 R6 Quick change / Front wheel	17 - 24	966*	△	△			834	△	△
YZF	700 R7	22 - 24	634*	△	△	△	△	657	△	△
YZF	1000 R1	15 - 24	634*	△	△	△	△	834	△	△
YZF	1000 R1 (4-pad)	07 - 14	839*	△		△	△	657	△	△
YZF	1000 R1 (4-pad) ABS	12 - 14	839*	△		△	△	657	△	△
YZF	1000 R1M	15 - 24	634*	△	△	△	△	834	△	△
YZF	1000 R1S	16 - 16	634*	△	△	△	△	834	△	△

Applications Racing

\* = 2 sets required / 2 jeux pour l'Avant.

△ = Available quality / Qualité disponible.

To select compound for racing front/rear - see page 19-22 / Pour sélectionner vos plaquettes racing avant/arrière - voir page 19-22.



# CALIPERS



@sbsbrakes | sbsbrakes.com | #GoAhead

HI-TECH BRAKE SOLUTIONS  
MADE IN EUROPE

**ACCOSSATO**

AGPZ01, 108 mm CNC Monoblock, 4 Piston/4 Pad	805
AGPZ02, 108 mm Forged Monoblock, 4 Piston/4 Pad	805
AGPZ03, 108 mm Forged Monoblock, 4 Piston/4 Pad	805
AGPZ04, 108 mm Forged Monoblock, 4 Piston/4 Pad	805
AGPZ05, 100 mm CNC Monoblock, 4 Piston/2 Pad	845
AGPZ06, 60 mm CNC Moto 3, 2 Piston/2 Pad	805
AGPZ07, 100 mm Forged Monoblock, 4 Piston/2 Pad	845

**A.P. RACING CALIPERS**

6 Piston 3366/3367 Series	660
6 Piston 4466/4477 Series	707
CP-2696-36E0/38E0	523
CP-3369-2E0/3E0	599
CP-3385-2E0/3E0	599
CP-3386-2E0/3E0	599
CP-3485-8S0/9S0	661
CP-3548	718
CP-3569-2S0/3S0	599
CP-3569-4S0/5S0	661
CP-3586-4S0/5S0	661
CP-3696-2E0	523
CP-3697-2E0	523
CP-3769-2S0/3S0	599
CP-4226-2S0/3S0	719
CP-4484-2S0/3S0	720
CP-4488 Two Pad Radial 4 Piston Monoblock	785
CP-4638-2E0	523
CP-6688 Four Pad Radial 4 Piston Monoblock	805

**BERINGER**

2 Piston Classic Billet Caliper	506
4 Piston Caliper	631
6 Piston Caliper	771
6 Piston Endurance Caliper	779

**BRAKING**

Front Cross	694
Front Harley Davidson	676
Rear cross (1 piston)	777
Rear cross (2 piston)	604
Street, Supermotard	706

**BREMBO RACING CALIPERS**

100 mm Motard Radial XA78910, P4 30/34	706
100 mm Radial 220A16810, P4 30/34	706
100 mm Radial 220A80310, P4 30/34	706
100 mm Radial Caliper .484, 220B47310, P4 32	841
100 mm Radial GP4 RX 220B01020 P4 32 (disc min. Th. 4.0 mm)	901
100 mm Radial GP4 RX 220B01020 P4 32 (disc min. Th. 4.5 mm)	841
100 mm Radial Monoblock 220988530, P4 34	841
100 mm Radial Monoblock XA7G210/11, P4 32/36	711
100 mm Radial Monoblock XA7G240/41, P4 32/36	711
108 mm Motard Radial XA69510, P4 30/34	706
108 mm Radial 220A01610, P4 30/34	706
108 mm Radial 220A80210, P4 30/34	706
108 mm Radial Caliper .484, 220B47310, P4 32	841
108 mm Radial GP4 RX 220B01020 P4 32 (disc min. Th. 4.0 mm)	901
108 mm Radial GP4 RX 220B01020 P4 32 (disc min. Th. 4.5 mm)	841
108 mm Radial Monoblock 220A39710, P4 34	841
108N, P2 38	506
130 mm Radial GP4 RX 220B01020 P4 32 (disc min. Th. 4.0 mm)	901
130 mm Radial GP4 RX 220B01020 P4 32 (disc min. Th. 4.5 mm)	841
Billet 20.4756.52/62, racing	566
Billet P2.24 X20.60.01, racing	732
F08	506
Floating Motocross Caliper 22.5930.62	671
Goldline 20.5161.42/51, road	519
Goldline 20.6951.50, road	730
Goldline 4 pad 20.7850.11/21, road	762
Goldline single pin 20.5165.55/65, road	566
Goldline two pin 20.6800, road	706
GP X10.48.13/14, racing	695

**BREMBO RACING CALIPERS**

Monoblock X101740/41, P4 32/36	711
Motard Axial XA32950, P4 34	762
Moto3/SBK XA88810/11, P2 34	887
Moto3/SBK XA88820/21, P2 34	887
Motocross Caliper 22.2180.20	675
Off Road 122A99021, P2 24	671
Off Road XQ21361, P2 28	671
Off Road XQ21390, PF 26	791
Racing rear X206001, P2 24	759
Racing rear X206101, P4 24 (24 mm disc height)	942
Racing rear X206101, P4 24 (30 mm disc height)	941
Racing rear X206121, P4 24 (24 mm disc height)	942
Racing rear X206121, P4 24 (30 mm disc height)	941
Racing rear X988870, P2 34 (24 mm disc height)	942
Racing rear X988870, P2 34 (30 mm disc height)	941
Racing rear XA1J040, P2 30 (24 mm disc height)	942
Racing rear XA1J040, P2 30 (30 mm disc height)	941
Radial 220A16820, P4 30/34	706
Radial GP4 RX 220B01010	841
Radial Monoblock X973760/61, P4 32/36	711
Radial Monoblock X99C460/61, P4 34	805
Radial Monoblock XA8Y310/11	845
Radial Monoblock XA93310/11	711
Radial XA3B830/31, P4 32/36	711
Radial XA3B860/61, P4 32/36	711
SBK Racing DX XB0.B1.31, P4 30/34	889
SBK Racing DX XB0.B1.31, P4 30/34 (for Radiators X93.12.50)	909
SBK Racing SX XB0.B1.30, P4 30/34	889
SBK Racing SX XB0.B1.30, P4 30/34 (for Radiators X93.12.50)	909
Supersport 120A44110, P2 34	730

**GALESPEED**

2 Piston Axial Rear Caliper, GSRCA34AF	730
2 Piston Axial Rear Caliper, GSRCA34AT	730
2 Piston Radial Front Caliper, GSFCAR34F(Right)/GSFCAL34F(Left)	887
2 Piston Radial Front Caliper, GSFCAR34T(Right)/GSFCAL34T(Left)	887
2 Piston Radial Rear Caliper, GSRCA30F (30 mm Piston)	730
2 Piston Radial Rear Caliper, GSRCA30T (30 mm Piston)	730
2 Piston Radial Rear Caliper, GSRCA34F (34 mm Piston)	730
2 Piston Radial Rear Caliper, GSRCA34T (34 mm Piston)	730
4 Piston Axial Front Caliper, GSFCAR3430AF(Right)/GSFCAL3430AF(Left)	695
4 Piston Axial Front Caliper, GSFCAR3430AT(Right)/GSFCAL3430AT(Left)	695
4 Piston Radial Front Caliper, GSFCAR3430F(Right)/GSFCAL3430F(Left)	695
4 Piston Radial Front Caliper, GSFCAR3430T(Right)/GSFCAL3430T(Left)	695

**GMA**

2 Piston Caliper, large Model A	512
2 Piston Caliper, small Model B	560
4 Piston front Model F	559

**HARRISON/BILLET CALIPERS**

4 Piston Billet	737
Big-6	737
Mini-6	656

**HEL**

4 Piston Billet Caliper	809
-------------------------	-----

**HHI**

4 Piston Caliper	678
6 Piston Caliper	676

**ISR CALIPERS**

2 Piston (22-023/026)	504
2 Piston (22-027/028/029)	519
2 Piston (22-030/033)	523
2 Piston (22-036)	655
4 Piston (22-025)	519
4 Piston (22-043)	655
6 Piston Racing Caliper, large	656
6 Piston Racing Caliper, small	655

**J.JUAN**

Big Brake Kit X3	959
Fixed 2p radial caliper 82 mm	962

**JAYBRAKE**

2 Piston Caliper ADC/ADCS	560
2 Piston Dual Series Caliper	559
4 Piston Caliper A4 P/L	686
4 Piston J-Four Caliper	686
4 Piston Quad Series Caliper	559

**MOTO-MASTER**

Supermoto Racing Caliper	631
--------------------------	-----

**MOTOR FACTORY**

4 Piston Caliper front/rear	678
-----------------------------	-----

**NISSIN**

3 Piston Racing Rear Caliper	766
4 Piston Caliper	624
4 Piston Racing Caliper (1)	711
4 Piston Racing Caliper (2)	825
4 Piston Racing Caliper (510-C00-91N/510-C10-91N)	950
6 Piston Racing Caliper	729
6 Piston Racing Radial Monobloc Caliper (Z0901)	865

**PERFORMANCE MACHINE**

112 X 6B	729
112 X 6QC	729
112 X 6RSB	683
112 X 6SSB	683
124 X 4HR	662
125 X 2	559
125 X 4R	678
125 X 4RSPH	678
125 X 4S	559
125 X 4SL	559
125 X 6	658
125 X 6QC	683
137 X 4	662
137 X 4B	678
137 X 6	658
162 X 2	509
4 Piston Vintage Caliper	678

**PFM**

6 Piston Racing Caliper	707
-------------------------	-----

**PVM**

4 Pad Caliper	805
---------------	-----

**REBUFFINI**

Kalipso	676
Kerio	676
RR108	676

**REVTECH**

Wilwood Caliper front/rear	566
----------------------------	-----

**SJP**

2 Piston Caliper (30-375)	559
4 Piston Caliper (30-370)	559

# NEW! Get the brake feel you want!

# sbs<sup>®</sup>

GO AHEAD

Find the right brake pad compound for you and  
your bike with the new Compound Selector at  
[sbsbrakes.com](http://sbsbrakes.com)

Find the right compound for you and  
your bike

Click Start Now, answer 2-3 questions and get the answer right away

START NOW



@sbsbrakes | [sbsbrakes.com](http://sbsbrakes.com)

HI-TECH BRAKE SOLUTIONS  
MADE IN EUROPE



# BRAKE PADS

1:1 DRAWINGS, COMPOUNDS, FITMENTS

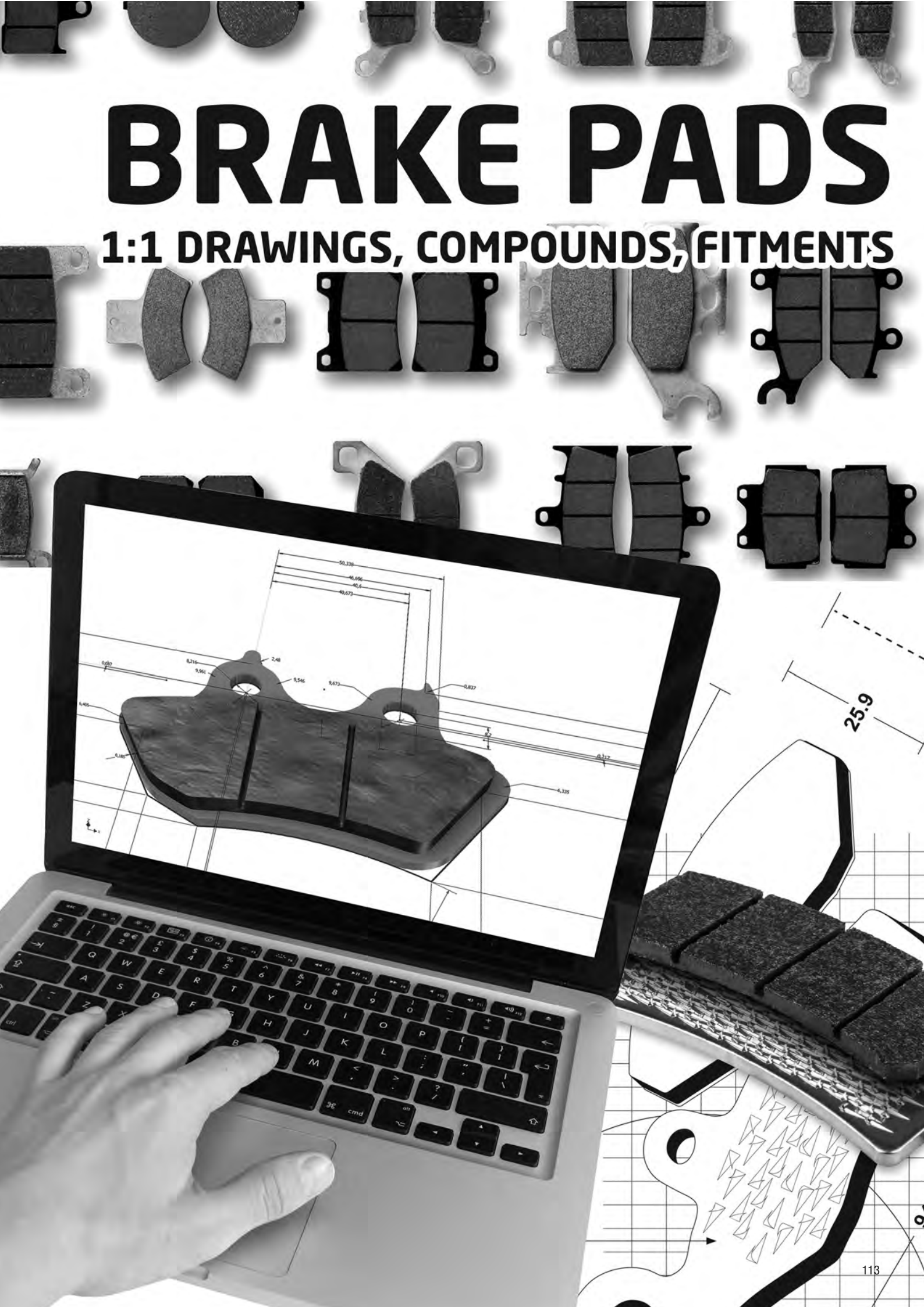

## Applications

### SBS 100

#### Recommended compound



DAELIM			
50 Delfino	99 - 99	HF	
50 E-Five	03 - 08	HF	
50 History, S-Five	01 - 01	HF	HF
50 Message II	02 - 02	HF	
50 Tapo	99 - 04	HF	
50 Vivo	99 - 99	HF	
SE 50 Cordi	06 - 12	HF	
100 Delfino	99 - 04	HF	
125 Altino	02 - 04	CT	
125 DLX, Otello DLX	01 - 02	CT	CT
125 History	01 - 06	CT	CT
125 Message II	00 - 00	CT	
125 Otello	99 - 00	CT	
125 Otello	08 - 08		CT
125 S2	06 - 08		CT
125 S2 FI	07 - 15		CT
NS 125 II	00 - 00		CT
SL 125 U3 FI	07 - 09		CT



DAELIM			
250 S2	06 - 10		CT
HONDA			
CRM 50	88 - 92	HF	
MB 50 S	80 - 82	HF	
MBX 50	80 - 82	HF	
MRX 50	88 - 92	HF	
SP 50	91 - 91	HF	
CB 80	80 - 81	HF	
PEUGEOT			
50 Vivacity	08 - 14	HF	
SACHS			
50 MadAss 4T	05 - 09		HF
125 MadAss	09 - 09		HF

### SBS 101

#### Recommended compound



AEON			
50 Aero	06 - 06	HF	
50 Regal	06 - 06	HF	
50 Torch	06 - 09	HF	
90 Regal	06 - 06	HF	
100 Pulsar	06 - 06	HF	
110 Aero	06 - 06	HF	
110 Pulsar	06 - 06	HF	
125 Co-In	14 - 14	CT	
125 Elite	13 - 14		CT
125 Urban	11 - 13		CT
150 Pulsar	06 - 06	CT	
250 Elite	11 - 14		CT
350 Urban	11 - 13		CT
APRILIA			
RS-4 50	12 - 19		HF
RS-4 50 Replica	16 - 17		HF
SX 50 Ltd.	07 - 15		CT
BENELLI			
350 Zenzero	12 - 15		CT
CPI			
50 Baby	02 - 02	HF	
50 Hussar	01 - 02	HF	
50 Mars	01 - 02	HF	
50 Popcorn	01 - 02	HF	
FANTIC			
50 Regolarna Casa	08 - 09		HF
50 Supersei Motard	08 - 09		HF
GARELLI			
125 Raider	02 - 02		CT
HYOSUNG			
50 Avanti	99 - 02	HF	
50 Rush	97 - 01	HF	
50 Sense	98 - 07	HF	
50 Super Cab	95 - 98	HF	
50 Super Cab Plus	98 - 98	HF	
SB 50	00 - 03	HF	
SB 50 P	00 - 03	HF	
SD 50	00 - 06	HF	



HYOSUNG			
SF 50	99 - 06	HF	
100 Cab	98 - 01	HF	
EZ 100	00 - 05	HF	
110 Midas Plus	98 - 04	HF	
FX 110 110	02 - 04	HF	
KR 110 Master	04 - 05	HF	
ITALJET			
100 Millennium 2T	01 - 01	HF	
125 Millennium	00 - 03	CT	
150 Millennium	00 - 03	CT	
KEEWAY			
50 Flash	07 - 12	HF	
50 Hurricane	06 - 16	HF	
90 Hurricane	06 - 09	HF	
MAICO			
50 Cruiser	99 - 99	HF	
50 Thunderbike I	99 - 99	HF	
50 Thunderbike II	99 - 99	HF	
C-1 50 Hard Enduro	99 - 99	HF	
R-1 50 Superbike	99 - 99	HF	
X-1 50 SuperCross	99 - 99	HF	
MZ			
50 (MUZ) Moskito SX	00 - 02	HF	
PETERSON			
50 Hurricane	95 - 95	HF	
SR 50 Racing	95 - 95	HF	
80 Hurricane	95 - 95	HF	
SR 80 Racing	95 - 95	HF	
PGO			
50 Big Max	03 - 17	HF	
50 Comet	91 - 92	HF	
50 Galaxy	91 - 97	HF	
50 Road 66	95 - 95	HF	
PS 50	93 - 93	HF	
90 Galaxy	92 - 94	HF	
PIAGGIO VESPA			
50 New Liberty S	16 - 19	HF	



PIAGGIO VESPA			
50 Typhoon	06 - 14	HF	
NRG 50 Power DD	06 - 16	HF	
NRG 50 Purejet	06 - 07	HF	
QUADRO			
350 3	16 - 16		MS
350 4	16 - 16		MS
D 350	11 - 15		CT
RIEJU			
RS2 50 NKD	06 - 10		HF
RS3 50	12 - 17		HF
SULA			
50 Thunder Bird	99 - 99	HF	
100 Thunder Bird	99 - 99	HF	
125 Thunder Bird	99 - 99	CT	
SUZUKI			
AE 50 R/L	88 - 93	HF	
AH 50 Adress	92 - 95	HF	
CP 50	85 - 90	HF	
CR 50 DC	87 - 87	HF	
ZZ 50 Scooter	92 - 92	HF	
AH 80 Adress, V, Tune	88 - 91	HF	
AH 100 V Adress	91 - 94	HF	
AN 125	06 - 08	CT	
LIDO 125 Vario Scooter	90 - 93	CT	
UE 125	01 - 03	CT	
UE 150 CT	02 - 03	CT	
TGB			
50 101R	05 - 09	HF	
50 101S	99 - 02	HF	
50 202T	99 - 02	HF	
50 303R	99 - 14	HF	
50 309 Racing	05 - 05	HF	
50 507	05 - 05	HF	
50 Akros	99 - 04	HF	
50 Bull&t RS/RR	11 - 17		HF
50 Bullet	09 - 09	HF	HF
50 Bunny	97 - 00	HF	
50 Double X	05 - 05	HF	
50 Ergon	96 - 00	HF	

STREET  
AMERICAN  
SCOOTER

HF • HS • LS  
H.HF • H.CT • H.HS • H.LS  
HF • CT • MS

RACING  
OFF ROAD  
ATV

RST • DC • DCC • DS-1 • DS-2 • RQ  
SI • RSI • CS  
ATS • SI • RSI • PSI

Drawings 1:1

Available compounds

HF • CT

SBS 100

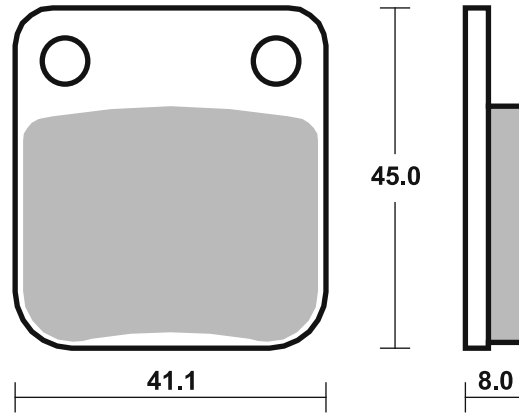

Available compounds

HF • CT • MS

SBS 101

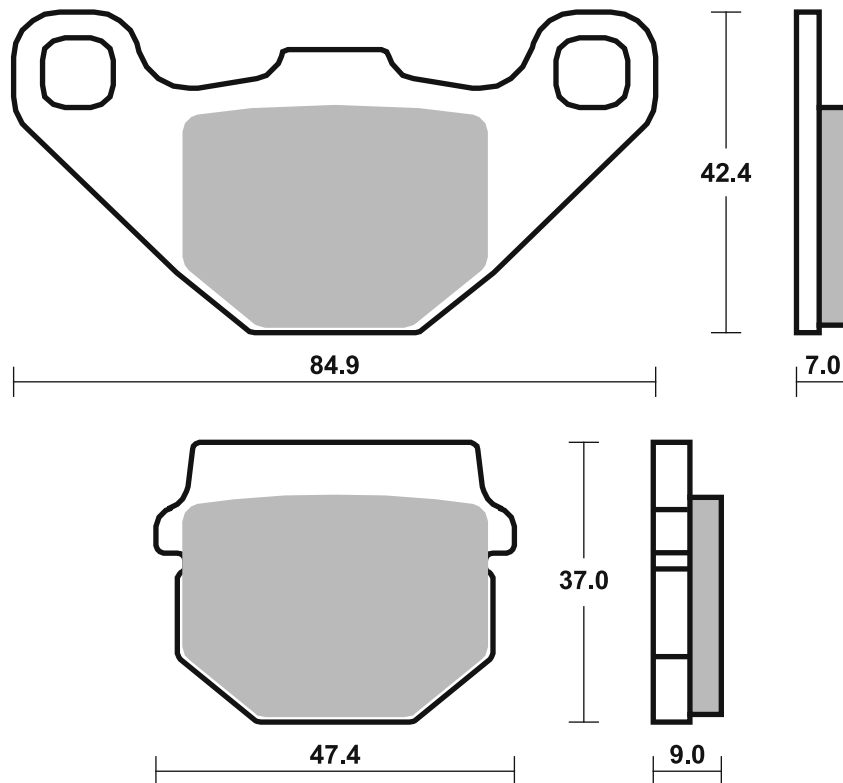

## Applications

### SBS 101

### Recommended compound



<b>TGB</b>			
50 Hawk	09 - 14	<b>HF</b>	
50 Hiw's	99 - 99	<b>HF</b>	
50 Hook	10 - 12	<b>HF</b>	
50 J409	00 - 03	<b>HF</b>	
50 Tapo RS	11 - 12	<b>HF</b>	
50 Trigger	99 - 03	<b>HF</b>	
<b>R</b>			<b>HF</b>
50 X	06 - 14		
90 101S	99 - 02	<b>HF</b>	
90 202T	99 - 02	<b>HF</b>	
90 Akros	99 - 99	<b>HF</b>	
90 Ergon	99 - 02	<b>HF</b>	
90 Hiw's	99 - 99	<b>HF</b>	
90 Trigger	99 - 02	<b>HF</b>	
125 101S	99 - 03	<b>CT</b>	
125 202T	99 - 99	<b>CT</b>	
125 303R	99 - 08	<b>CT</b>	
125 309 RS	00 - 00	<b>HF</b>	
125 Bull&t RS/RR	11 - 14		<b>HF</b>
125 Hook	10 - 10	<b>HF</b>	
<b>UVM</b>			
50 BeThere	99 - 99	<b>HF</b>	
50 Bingo	99 - 99	<b>HF</b>	
125 BeThere	99 - 99	<b>CT</b>	
125 Bingo	99 - 99	<b>CT</b>	
125 Paragon	99 - 99	<b>CT</b>	

### SBS 102

### Recommended compound



<b>ADLY</b>			
50 Panther	01 - 09	<b>HF</b>	
50 Silver Fox	06 - 09	<b>HF</b>	
50 Super Sonic	00 - 05	<b>HF</b>	
50 Thunderbike	97 - 09	<b>HF</b>	
<b>RS</b>			<b>HF</b>
50 Super Sonic	06 - 08	<b>HF</b>	
100 Panther	01 - 06	<b>HF</b>	
100 Silver Fox	06 - 06	<b>HF</b>	
100 Super Sonic	01 - 05	<b>HF</b>	
100 Thunderbike	01 - 04	<b>HF</b>	<b>HF</b>
125 Super Sonic	01 - 05	<b>CT</b>	
125 Thunderbike	01 - 04	<b>CT</b>	<b>CT</b>
<b>EASY RIDER</b>			
50 Easy Rider	99 - 99	<b>HF</b>	
<b>GILERA</b>			
50 Eaglet	97 - 99		<b>HF</b>
<b>KREIDLER</b>			
25 Florett XL	99 - 06	<b>HF</b>	
50 Florett	99 - 06	<b>HF</b>	
<b>MALAGUTI</b>			
125 Blog	10 - 10		<b>CT</b>
125 Monte	20 - 20		<b>CT</b>
160 Blog	10 - 11		<b>CT</b>
<b>PEUGEOT</b>			
50 Buxy (Hengtong cal.)	94 - 97	<b>HF</b>	
50 Kisbee	10 - 14	<b>HF</b>	
50 Kisbee RS	11 - 17	<b>HF</b>	



<b>PEUGEOT</b>			
50 Speedake			
(Hengtong cal.)	94 - 01	<b>HF</b>	
50 Speedfight LC,			
(Hengtong cal.)	96 - 15	<b>HF</b>	
50 Squab			
(Hengtong cal.)	94 - 04	<b>HF</b>	
50 Trekker Offroad	99 - 01	<b>HF</b>	
50 Vivacity			
(Hengtong cal.)	05 - 07	<b>HF</b>	
100 Vivacity			
(Hengtong cal.)	05 - 07	<b>HF</b>	
<b>SIAM</b>			
50 Mat	97 - 97	<b>HF</b>	
100 Mat	97 - 97	<b>HF</b>	
<b>SMC</b>			
50 Easy Rider	97 - 97	<b>HF</b>	
<b>SUZUKI</b>			
AJ 50 Sepia	92 - 96	<b>HF</b>	
AH 80 Scooter	92 - 94	<b>HF</b>	



STREET  
AMERICAN  
SCOOTER

HF • HS • LS  
H.HF • H.CT • H.HS • H.LS  
HF • CT • MS

RACING  
OFF ROAD  
ATV

RST • DC • DCC • DS-1 • DS-2 • RQ  
SI • RSI • CS  
ATS • SI • RSI • PSI

Available compounds

HF • CT • MS

SBS 101

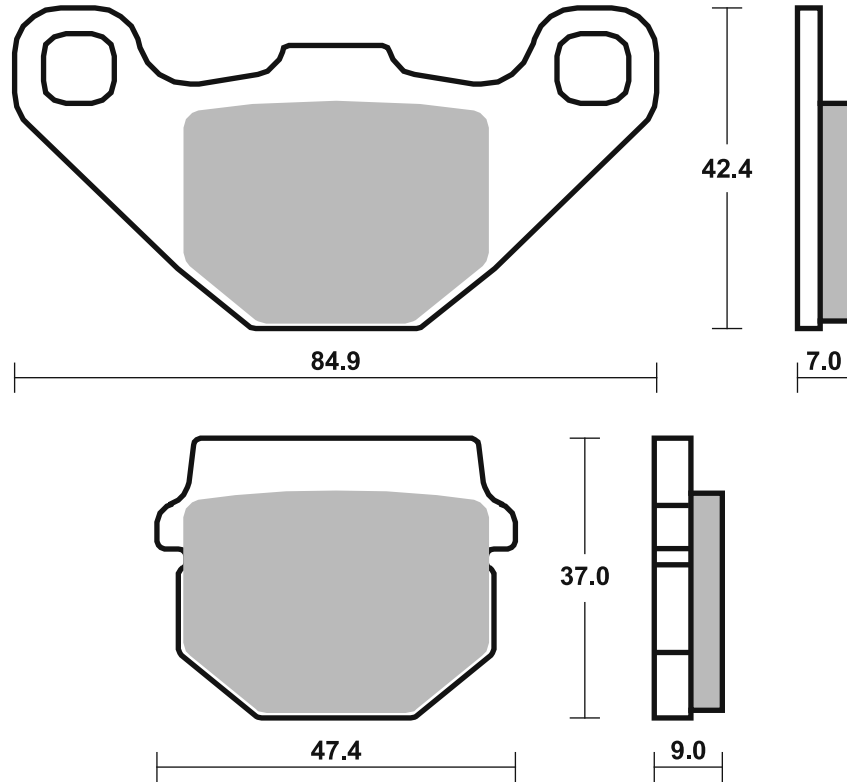

Available compounds

HF • CT

SBS 102

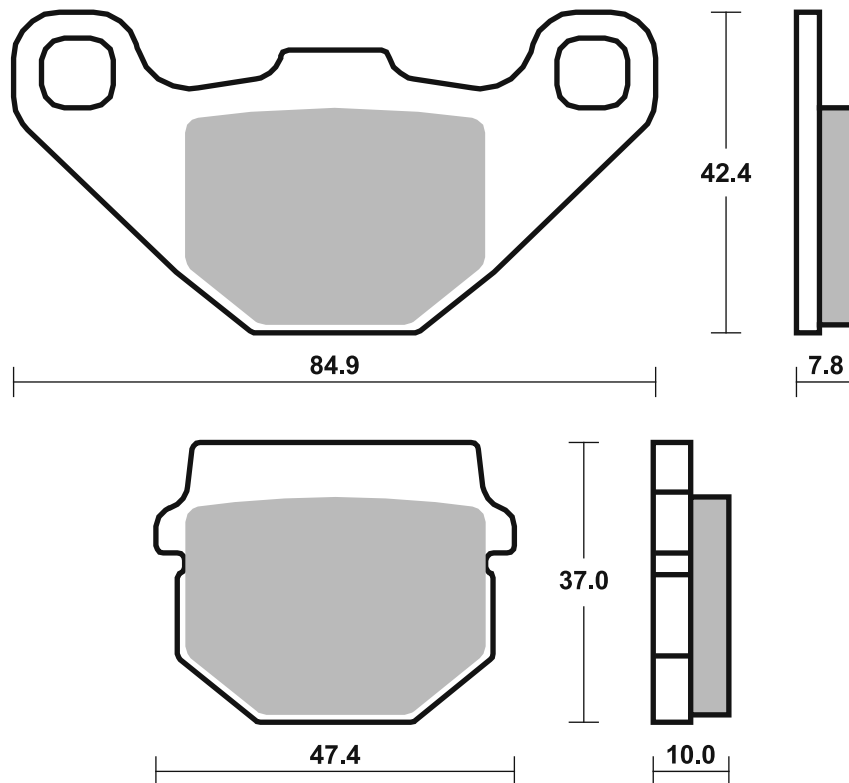

## Applications

### SBS 103

#### Recommended compound



<b>CAGIVA</b>			
50 Mito	99 - 06	<b>HF</b>	
125 Stella	97 - 08	<b>CT</b>	
<b>DAELIM</b>			
110 City Ace	03 - 07	<b>HF</b>	
<b>GARELLI</b>			
125 Joker 2	02 - 02	<b>CT</b>	
150 Joker 2	02 - 02	<b>CT</b>	
<b>HONDA</b>			
MBX 50 S	83 - 85	<b>HF</b>	
NS 50 F, Aero	88 - 91	<b>HF</b>	
NS-1 50	91 - 94	<b>HF</b>	
NSR 50	89 - 90	<b>HF</b>	
NSR 75 FI	88 - 00	<b>HF</b>	
NSR 80 R	87 - 92	<b>HF</b>	



<b>HYOSUNG</b>			
125 Boomer	03 - 03	<b>CT</b>	
125 Exceed	02 - 06	<b>CT</b>	
150 Exceed	02 - 04	<b>CT</b>	
<b>KYMCO</b>			
100 Spike	02 - 06	<b>HF</b>	
110 Spike	03 - 06	<b>HF</b>	
125 Jetix	08 - 15	<b>CT</b>	
125 Spike	02 - 06	<b>CT</b>	
<b>MZ</b>			
125 Mantizz S	07 - 07	<b>CT</b>	
<b>SYM</b>			
125 Wolf Legend	02 - 05	<b>CT</b>	

### SBS 104

#### Recommended compound



<b>HONDA</b>			
NH 100 Lead	00 - 08	<b>HF</b>	
NHX 110	10 - 12	<b>CT</b>	
NES 125 @	01 - 06	<b>CT</b>	
NES 150 @	01 - 06	<b>CT</b>	
CH 250 Spacy, Freeway Fusion	88 - 93	<b>MS</b>	
<b>PGO</b>			
50 T-Rex 3 (TR3-50)	02 - 16	<b>HF</b>	
<b>SUZUKI</b>			
250 Sky Wave Type II	98 - 01	<b>MS</b>	
AN 250 Burgman	98 - 03	<b>MS</b>	
AN 400 Burgman	99 - 00	<b>MS</b>	

### SBS 105

#### Recommended compound



<b>APRILIA</b>			
RS 50	06 - 11	<b>HF</b>	
RX 50	06 - 14	<b>HF</b>	
<b>BARIGO</b>			
Scooter electric	97 - 97	<b>HF</b>	
<b>BETA</b>			
50 Eikon	99 - 03	<b>HF</b>	<b>HF</b>
50 Techno	96 - 96	<b>HF</b>	<b>HF</b>
50 Tempo	92 - 96	<b>HF</b>	
RR 50 Enduro	99 - 09	<b>HF</b>	
RR 50 Pro Race	98 - 98	<b>HF</b>	
RR 50 Standard	99 - 08	<b>HF</b>	
RR 50 Supermotard	99 - 07	<b>HF</b>	
RR 50 Supermotard	04 - 07	<b>HF</b>	<b>HF</b>
125 Eikon	99 - 03	<b>CT</b>	<b>CT</b>
150 Eikon	99 - 03	<b>CT</b>	<b>CT</b>
250 Eikon	99 - 10	<b>CT</b>	<b>CT</b>



<b>BULTACO</b>			
50 Astro	01 - 06	<b>HF</b>	
50 Lobito	99 - 06	<b>HF</b>	
<b>CAGIVA</b>			
50 Corsa	98 - 98	<b>HF</b>	
50 Mantis	99 - 99	<b>HF</b>	
50 Mito	99 - 06	<b>HF</b>	<b>HF</b>
50 Progress	98 - 99	<b>HF</b>	
<b>CPI</b>			
50 Supermoto, Supercross	03 - 09	<b>HF</b>	<b>HF</b>
<b>DERBI</b>			
50 Atlantis	99 - 08	<b>HF</b>	
50 Atlantis 4T	04 - 10	<b>HF</b>	
50 Atlantis Bullet	04 - 05	<b>HF</b>	
50 Atlantis H2O	01 - 01	<b>HF</b>	



<b>DERBI</b>			
50 Atlantis H2O Wave	01 - 01	<b>HF</b>	
50 Atlantis Wave	01 - 02	<b>HF</b>	
50 Aventura	96 - 96	<b>HF</b>	
50 Black Devil	04 - 04	<b>HF</b>	
50 DRD Pro corse	06 - 08	<b>HF</b>	
50 DRD Racing R	05 - 10	<b>HF</b>	
50 DRD Racing R Ltd.	05 - 05	<b>HF</b>	
50 DRD Racing SM	05 - 05	<b>HF</b>	
50 DRD Racing SM Ltd.	05 - 05	<b>HF</b>	
50 Fenix	94 - 07	<b>HF</b>	<b>HF</b>
50 Furax	96 - 98	<b>HF</b>	<b>HF</b>
50 Hunter	97 - 99	<b>HF</b>	
50 Manhattan	99 - 99	<b>HF</b>	
50 Predator LC	99 - 02	<b>HF</b>	<b>HF</b>
50 Predator O2	00 - 02	<b>HF</b>	<b>HF</b>
50 Rambla	06 - 06	<b>HF</b>	<b>HF</b>
50 Savannah	91 - 97	<b>HF</b>	
50 Senda L	99 - 01	<b>HF</b>	<b>HF</b>

STREET  
AMERICAN  
SCOOTER

HF • HS • LS  
H.HF • H.CT • H.HS • H.LS  
HF • CT • MS

RACING  
OFF ROAD  
ATV

RST • DC • DCC • DS-1 • DS-2 • RQ  
SI • RSI • CS  
ATS • SI • RSI • PSI

Drawings 1:1

Available compounds

HF • CT

SBS 103

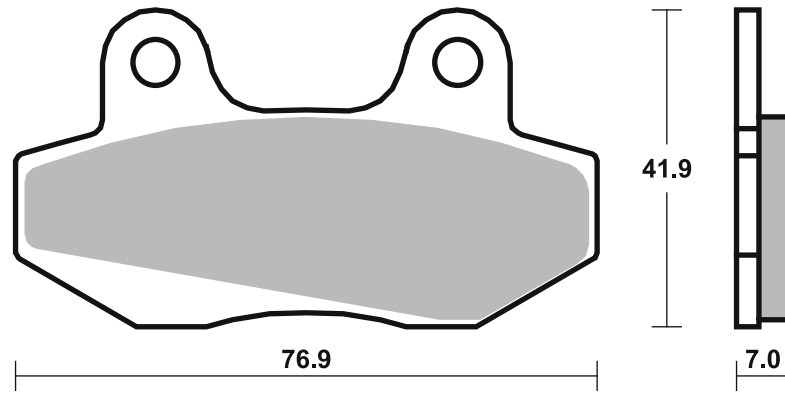

Available compounds

HF • CT • MS

SBS 104

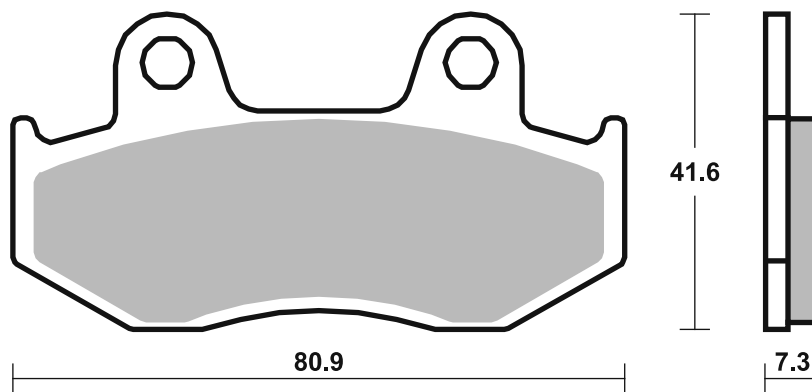

Available compounds

HF • CT

SBS 105

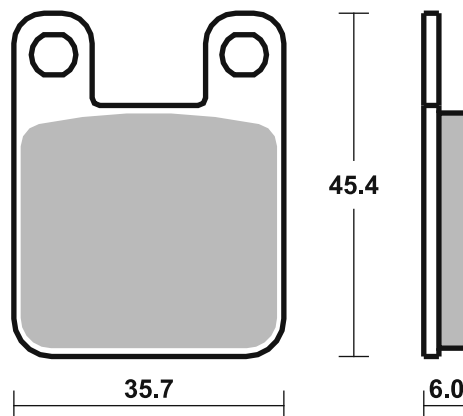

If required with springs -  
see SBS 188



<b>DERBI</b>			
50 Senda R DRD	03 - 04	HF	
50 Senda R, X-Treme	94 - 04	HF	HF
50 Senda SM DRD	03 - 04	HF	HF
50 Senda SM DRD			
Black Edition	03 - 04	HF	
50 Senda SM, X-Treme	99 - 06	HF	HF
50 Stinger	96 - 96	HF	
50 Vamos FL	95 - 99	HF	
50 Vamos L	95 - 95	HF	
50 Vamos R (A.J.P. cal.)	95 - 95	HF	
50 Variant Sport-R	01 - 13	HF	
50 X-Race R	05 - 09	HF	HF
50 X-Treme R	05 - 05	HF	HF
GP 50	01 - 01	HF	
GP1 50	01 - 03	HF	HF
GP1 50	05 - 05	HF	
GPR 50 R	98 - 03	HF	
GPX1 50	06 - 06	HF	HF
ST 50 Paddock	96 - 99	HF	
100 Atlantis 4T	04 - 06	HF	
100 Atlantis O2/H2O	01 - 01	HF	
125 Predator	99 - 99	CT	

<b>FACTORY</b>			
RP 50 Desert	04 - 04	HF	
SM 50 Chrono	04 - 04	HF	
SP 50 Chrono	04 - 04	HF	
YR 50 Desert	04 - 04	HF	

<b>FANTIC</b>			
50 Trial .5 .7 .9	89 - 91	HF	HF

<b>GARELLI</b>			
50 Xo	12 - 12	HF	
GSP 50	12 - 12	HF	

<b>GILERA</b>			
50 H@k	99 - 02	HF	HF
50 Zulu	01 - 03	HF	HF
GSM 50 Supermotard	01 - 13	HF	HF
RCR 50	04 - 13	HF	HF
SMT 50	04 - 13	HF	HF
125 GSM	00 - 00	CT	CT
SC 125	06 - 07	CT	CT

<b>HERO ENVOY</b>			
50	99 - 99	HF	

<b>HRD</b>			
50 Sonic 2 Supermotard	00 - 02	HF	
50 Sonic 2 Trail	00 - 02	HF	

<b>HUSQVARNA</b>			
50 Racing	98 - 98	HF	
SM 50	02 - 02	HF	HF
WR 50	02 - 02	HF	HF
WRS 50	98 - 98	HF	

<b>ITALJET</b>			
50 Dragster	99 - 06	HF	HF
50 Formula Air	99 - 00	HF	
50 Formula L.C.	98 - 00	HF	HF
50 Torpedo	98 - 99	HF	
50 Torpedo 4T	01 - 03	HF	
125 Dragster	99 - 03	CT	CT
125 Formula L.C.	99 - 03	CT	CT
125 Jupiter	02 - 03	CT	CT
125 Torpedo	99 - 06	CT	
125 Twin	98 - 01	CT	CT
150 Jupiter	02 - 03	CT	CT



<b>ITALJET</b>			
150 Torpedo 4T	01 - 01	CT	
180 Dragster	99 - 03	CT	CT

<b>MACAL</b>			
AM5/6 50 Trophy	99 - 99	HF	
AM5/6 50 Trophy H2O	99 - 99	HF	

<b>MALAGUTI</b>			
50 Fifty	04 - 04	HF	
NKD 50	04 - 09	HF	
XSM 50	03 - 14	HF	
XTM 50	03 - 11	HF	HF

<b>MBK</b>			
50 X-Limit	04 - 16	HF	HF
50 X-Power	04 - 13	HF	

<b>MINARELLI</b>			
MR 80	96 - 96	HF	

<b>MOTORHISPANIA</b>			
MH 50 Furia 6v	99 - 99	HF	HF
MH 50 Furia Max	06 - 10	HF	HF
MH 50 Urban Bike	06 - 10	HF	
RX 50 Racing	00 - 05	HF	HF
RYZ 50 Enduro	05 - 13	HF	HF
RYZ 50 Supermotard	05 - 10	HF	HF

<b>PEUGEOT</b>			
50 Blaster	09 - 12	HF	
50 Blaster Furios	11 - 12	HF	HF
50 Blaster RS12	09 - 12	HF	
50 Buxy (A.J.P. cal.)	94 - 97	HF	
50 Elyseo	02 - 05	HF	HF
50 Elyseo (A.J.P. cal.)	99 - 01	HF	
50 Elystar	03 - 05	HF	
50 Jet C-Tech	09 - 09	HF	HF
50 Jet-Force	03 - 10	HF	HF
50 Looxor	02 - 06	HF	
50 Ludix	04 - 08	HF	
50 Speedake (A.J.P. cal)	94 - 01	HF	
50 Speedfight 2 A/C	01 - 08	HF	
50 Speedfight 2 L/C	01 - 08	HF	HF
50 Speedfight 2 X-Race,			
Furious, 206 WRC	01 - 02	HF	HF
50 Speedfight			
LBD/LBDP	00 - 00	HF	HF
50 Speedfight LC,			
(A.J.P. cal.)	96 - 15	HF	
50 Speedfight Lemans	11 - 11	HF	HF
50 Squab (A.J.P. cal.)	94 - 04	HF	
50 TKR Furious	05 - 10	HF	
50 TKR WRC	05 - 10	HF	
50 Trekker Metal-X	01 - 08	HF	
50 Trekker Road	99 - 00	HF	
50 Trekker Streetboard	00 - 02	HF	
50 Trekker Urban Black	00 - 00	HF	
50 Vivacity (A.J.P. cal.)	99 - 07	HF	
XP 6 50 Enduro	06 - 12	HF	HF
XP 6 50 Supermotard	06 - 12	HF	HF
XP 6 50 Trail	04 - 05	HF	HF
XP S-6 50 Enduro	02 - 05	HF	HF
XP S-6 50 Supermotard	04 - 05	HF	
XR 6 50 Race Spec	02 - 07	HF	
XR 7 50	08 - 10	HF	
100 Elyseo	02 - 05	HF	HF
100 Elyseo (A.J.P. cal.)	99 - 01	HF	
100 Looxor	02 - 07	HF	HF
100 Speedfight	00 - 07	HF	HF
100 Speedfight 2, X-Race	01 - 07	HF	HF



<b>PEUGEOT</b>			
100 Trekker Road	99 - 04	HF	
100 Vivacity (A.J.P. cal.)	99 - 07	HF	
125 Elyseo (A.J.P. cal.)	99 - 99	CT	
125 Ludix	04 - 05	CT	
125 Satelis	04 - 05	CT	

<b>PIAGGIO VESPA</b>			
50 Diesis	02 - 05	HF	
100 Diesis	02 - 03	HF	

<b>RIEJU</b>			
50 First, H2O	97 - 99	HF	
50 Racing Spec. Edition	01 - 01	HF	HF
50 Spike Racing	02 - 06	HF	HF
50 Spike Racing	02 - 06	HF	HF
50 Tango	08 - 12	HF	HF
50 Windy	97 - 97	HF	
MRX 50 , Racing	02 - 09	HF	HF
MRX 50 Pro	05 - 09	HF	HF
NKD 50	04 - 07	HF	
RRX 50	08 - 08	HF	HF
RRX 50 Spike	08 - 08	HF	HF
RS1 50 , Castrol	01 - 03	HF	
RS1 50 Evolution	96 - 00	HF	HF
RS3 50 Pro	12 - 17	HF	HF
SMX 50	02 - 09	HF	HF
SMX 50	02 - 09	HF	HF
SMX 50 Pro	08 - 09	HF	HF

<b>ROXON</b>			
50 Duel SM	06 - 06	HF	HF
50 Duel TT	06 - 06	HF	HF

<b>SHERCO</b>			
50 Supermotard, Enduro	02 - 06		HF

<b>SIMSON</b>			
125 Star	99 - 99	CT	

<b>SUZUKI</b>			
AY 50 , Katana	96 - 08	HF	
AY 50 W	00 - 04	HF	HF
AY 50 WR	00 - 05	HF	HF
RMX 50	00 - 02	HF	HF
SMX 50 Super Motard	00 - 02	HF	HF
UF 50 Estilete	00 - 02	HF	
UX 50 W Zillion	99 - 02	HF	

<b>TOMOS</b>			
50 Hip Hop	06 - 08	HF	
50 Racing	06 - 08	HF	
50 Street Soul	06 - 08	HF	
50 Youngst'r	06 - 08	HF	
SE 50	05 - 06	HF	HF

<b>YAMAHA</b>			
DT 50 R	04 - 08	HF	
TZR 50	03 - 04	HF	HF



STREET  
AMERICAN  
SCOOTER

HF • HS • LS  
H.HF • H.CT • H.HS • H.LS  
HF • CT • MS

RACING  
OFF ROAD  
ATV

RST • DC • DCC • DS-1 • DS-2 • RQ  
SI • RSI • CS  
ATS • SI • RSI • PSI

Available compounds

HF • CT

SBS 105

If required with springs -  
see SBS 188

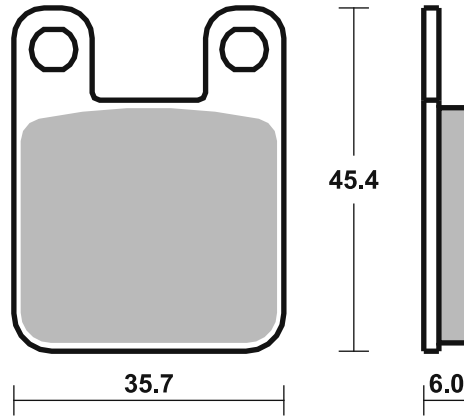

## Applications

### SBS 106

#### Recommended compound



<b>APRILIA</b>			
AF1	50 AE	86 - 96	<b>HF</b>
AF1	50 Europa, Futura	90 - 92	<b>HF</b>
MX	50	03 - 10	<b>HF</b>
RS	50	96 - 99	<b>HF</b>
RS	50 , Replica	00 - 05	<b>HF</b>
RX	50	90 - 05	<b>HF</b>
RX	50 Racing	04 - 06	<b>HF</b>
	125 Leonardo	96 - 96	<b>CT</b>
<b>CAGIVA</b>			
	50 Blues	89 - 89	<b>HF</b>
	50 Cocis	88 - 88	<b>HF</b>
<b>KYMCO</b>			
B	125 Freeway	93 - 95	<b>CT</b>

### SBS 107

#### Recommended compound



<b>GARELLI</b>			
	Xo Electric	12 - 12	<b>HF</b>
	125 Xo	12 - 12	<b>CT</b>
	150 Xo	12 - 12	<b>CT</b>
	200 Xo	12 - 12	<b>CT</b>
<b>MALAGUTI</b>			
	125 Centro ie	08 - 11	<b>CT</b>
	160 Centro ie	08 - 11	<b>CT</b>
<b>MBK</b>			
	125 Flame R/F	95 - 03	<b>CT</b>
	150 Vertex	97 - 97	<b>CT</b>
<b>YAMAHA</b>			
	50 Cygnus	96 - 01	<b>HF</b>
DT	50 R	89 - 97	<b>HF</b>
TDR	50	90 - 92	<b>HF</b>
TZM	50 R	94 - 97	<b>HF</b>



<b>YAMAHA</b>			
TZR	50	90 - 92	<b>HF</b>
	105 Crypton	98 - 04	<b>HF</b>
DT	125 R	96 - 07	<b>CT</b>
XC	125 Cygnus F	00 - 08	<b>CT</b>
XC	125 F	00 - 08	<b>CT</b>
XC	125 TR Cygnus, R	96 - 98	<b>CT</b>
XC	150 Fly One R	98 - 02	<b>CT</b>

### SBS 108

#### Recommended compound



<b>APRILIA</b>			
	125 Leonardo		
	(Grimeca cal.)	99 - 06	<b>CT</b>
	125 Scarabeo,		
	Scarabeo GT	99 - 03	<b>CT</b>
	125 Sportcity		
	(Grimeca cal.)	04 - 12	<b>CT</b>
	150 Leonardo		
	(Grimeca cal.)	99 - 05	<b>CT</b>
	150 Scarabeo	99 - 04	<b>CT</b>
	200 Scarabeo,		
	Scarabeo GT	02 - 03	<b>CT</b>
	200 Sportcity	04 - 08	<b>CT</b>
	250 Leonardo		
	(Grimeca cal.)	99 - 05	<b>MS</b>
	250 Sportcity	06 - 08	<b>MS</b>
	300 Leonardo		
	(Grimeca cal.)	05 - 06	<b>MS</b>
	400 Scarabeo ie	07 - 08	<b>MS</b>



<b>APRILIA</b>			
	500 Atlantic	02 - 05	<b>MS</b>
	500 Scarabeo	03 - 06	<b>MS</b>
	500 Scarabeo Classic	10 - 11	<b>MS</b>
	500 Scarabeo ie	07 - 11	<b>MS</b>
<b>CAGIVA</b>			
	50 Blues	89 - 89	<b>HF</b>
<b>DERBI</b>			
	125 Rambla	08 - 14	<b>CT</b>
	300 Rambla	08 - 12	<b>MS</b>
<b>GILERA</b>			
	125 Cougar	99 - 02	<b>CT</b>
<b>MALAGUTI</b>			
	125 Runner	87 - 87	<b>CT</b>
	125 Sport City Cube	08 - 08	<b>CT</b>



<b>MALAGUTI</b>			
	200 Sport City Cube	08 - 08	<b>CT</b>
	250 Sport City Cube	08 - 08	<b>MS</b>
	300 Sport City Cube	08 - 08	<b>MS</b>
GT	500 Spidermax	04 - 10	<b>MS</b>
RS	500 Spidermax	09 - 11	<b>MS</b>
<b>SIMSON</b>			
	125 Schikra	99 - 99	<b>CT</b>

STREET  
AMERICAN  
SCOOTER

HF • HS • LS  
H.HF • H.CT • H.HS • H.LS  
HF • CT • MS

RACING  
OFF ROAD  
ATV

RST • DC • DCC • DS-1 • DS-2 • RQ  
SI • RSI • CS  
ATS • SI • RSI • PSI

Available compounds

HF • CT

SBS 106

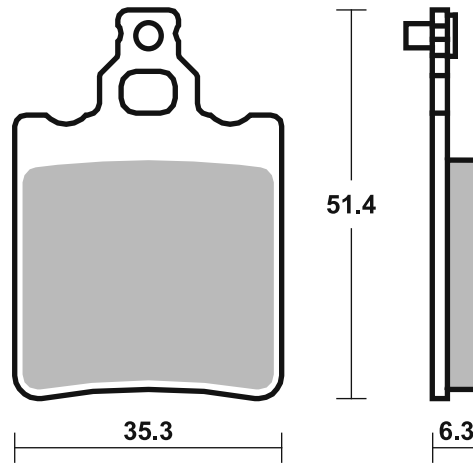

Available compounds

HF • CT

SBS 107

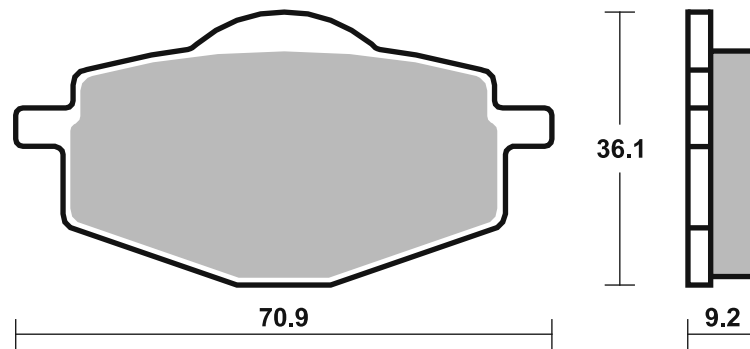

Available compounds

HF • CT • MS

SBS 108

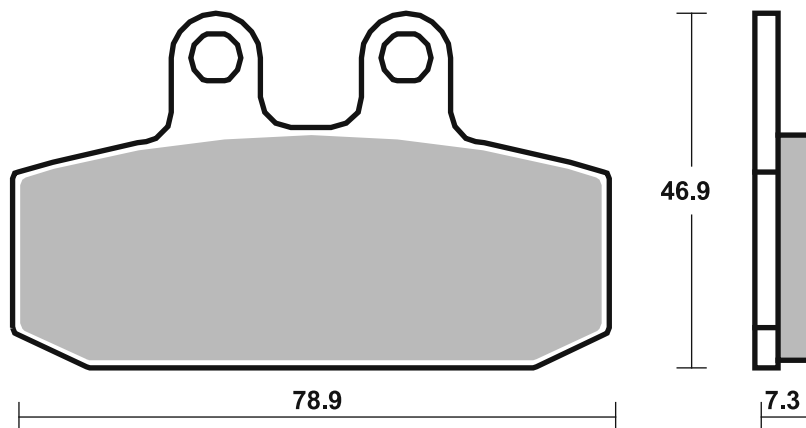

## Applications

### SBS 109

#### Recommended compound



<b>APRILIA</b>			
	50 Red Rose	90 - 94	<b>HF</b>
AF1	50 AE	86 - 96	<b>HF</b>
AF1	50 Europa, Futura	90 - 92	<b>HF</b>
<b>BENELLI</b>			
	50 Chrono	92 - 93	<b>HF</b>
<b>KTM</b>			
GO	50	94 - 97	<b>HF</b>
<b>MALAGUTI</b>			
	50 Centro	93 - 96	<b>HF</b>
F-12	50 Phantom L.C.	94 - 98	<b>HF</b>
F-15	50 Fire Fox L.C.	96 - 08	<b>HF</b>
<b>YAMAHA</b>			
DT	50 R	98 - 03	<b>HF</b>

### SBS 110

#### Recommended compound



<b>HONDA</b>			
NH	50 Lead	86 - 93	<b>HF</b>
NH	80 Lead Scooter	86 - 95	<b>HF</b>
<b>KYMCO</b>			
	50 Manboy	95 - 00	<b>HF</b>
	50 Zap (Disc Brake version)	95 - 00	<b>HF</b>
SP	90 Yup	95 - 99	<b>HF</b>
<b>SYM</b>			
	50 Bullet	93 - 93	<b>HF</b>
	50 Cinderella	01 - 00	<b>HF</b>
	50 Mio	05 - 16	<b>HF</b>
DD	50	02 - 12	<b>HF</b>
	100 Cinderella	01 - 01	<b>HF</b>
	100 Mio	05 - 16	<b>HF</b>

### SBS 111

#### Recommended compound



<b>ADLY</b>			
	25 Silver Fox	00 - 05	<b>HF</b>
	50 Cat	01 - 08	<b>HF</b>
	50 Cosy	01 - 08	<b>HF</b>
	50 Fox	00 - 09	<b>HF</b>
	50 Fox Plus	01 - 09	<b>HF</b>
	50 Jet	96 - 99	<b>HF</b>
	50 Pista, Pista Twin Light	96 - 99	<b>HF</b>
	50 Silver Fox	00 - 05	<b>HF</b>
RT	50 Road Tracer	02 - 06	<b>HF</b>
	70 Fox Plus	01 - 05	<b>HF</b>
	70 Pista, Pista Twin Light	01 - 05	<b>HF</b>
	80 Cosy	01 - 06	<b>HF</b>
RT	90 Road Tracer	02 - 06	<b>HF</b>
	100 Cat	01 - 10	<b>HF</b>
	100 Jet	96 - 99	<b>HF</b>
	100 Silver Fox	01 - 05	<b>HF</b>



<b>ADLY</b>			
RT	100 Road Tracer	02 - 06	<b>HF</b>
	125 Cat	01 - 04	<b>CT</b>
<b>BS VILLA</b>			
AX	50	93 - 93	<b>HF</b>
GZ	50	93 - 93	<b>HF</b>
<b>CAGIVA</b>			
	50 City	08 - 08	<b>HF</b>
<b>FANTIC</b>			
	50 Big Wheel	93 - 93	<b>HF</b>
	50 Grinta	95 - 96	<b>HF</b>
	50 Leader	95 - 95	<b>HF</b>
	50 Pony SR	93 - 95	<b>HF</b>
	50 Queenie	95 - 96	<b>HF</b>



<b>GARELLI</b>			
	50 Starter	02 - 02	<b>HF</b>
CPR	50	02 - 02	<b>HF</b>
FX	50	02 - 06	<b>HF</b>
PMX	50 Rally	00 - 00	<b>HF</b>
SR	50 Pony	95 - 02	<b>HF</b>
<b>ITALJET</b>			
	50 Bazooka	93 - 02	<b>HF</b>
	50 Cruise	95 - 97	<b>HF</b>
	50 Pista 2	92 - 97	<b>HF</b>
	50 Scoop	93 - 97	<b>HF</b>
	50 Yankee 8	94 - 02	<b>HF HF</b>
<b>LEM</b>			
	50 Flash	94 - 98	<b>HF</b>
<b>MBK</b>			
	50 Target	92 - 95	<b>HF</b>



STREET  
AMERICAN  
SCOOTER

HF • HS • LS  
H.HF • H.CT • H.HS • H.LS  
HF • CT • MS

RACING  
OFF ROAD  
ATV

RST • DC • DCC • DS-1 • DS-2 • RQ  
SI • RSI • CS  
ATS • SI • RSI • PSI

Available compounds

HF

SBS 109

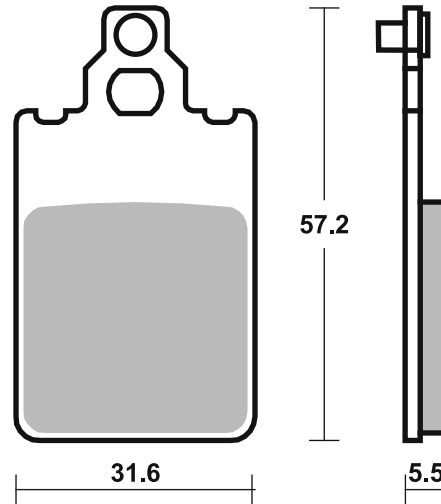

Available compounds

HF • CT

SBS 110

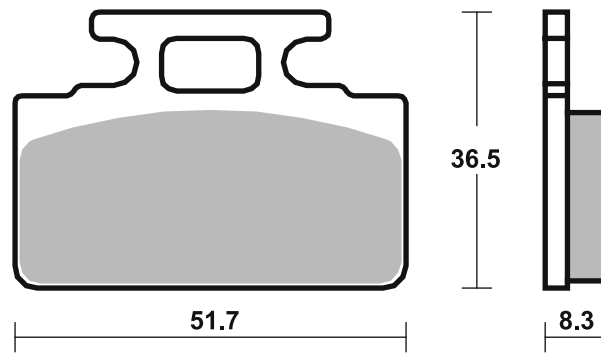

Available compounds

HF • CT

SBS 111

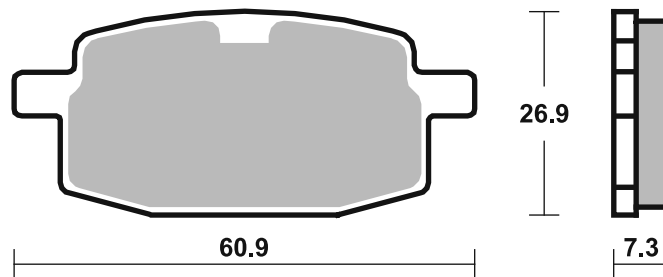



STREET  
AMERICAN  
SCOOTER

HF • HS • LS  
H.HF • H.CT • H.HS • H.LS  
HF • CT • MS

RACING  
OFF ROAD  
ATV

RST • DC • DCC • DS-1 • DS-2 • RQ  
SI • RSI • CS  
ATS • SI • RSI • PSI

Available compounds

HF • CT

SBS 111

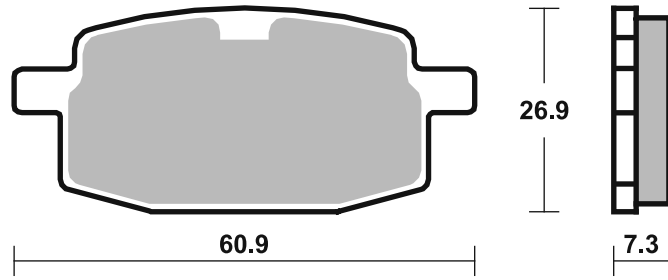

Available compounds

HF • CT

SBS 112

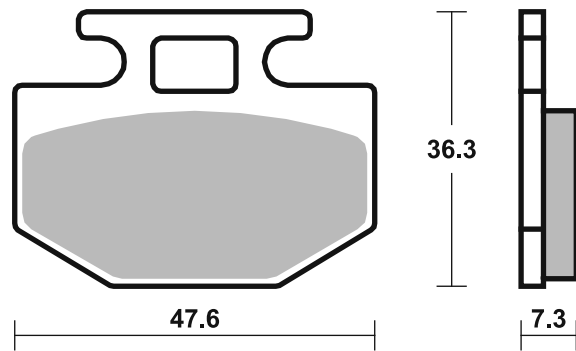





STREET  
AMERICAN  
SCOOTER

HF • HS • LS  
H.HF • H.CT • H.HS • H.LS  
HF • CT • MS

RACING  
OFF ROAD  
ATV

RST • DC • DCC • DS-1 • DS-2 • RQ  
SI • RSI • CS  
ATS • SI • RSI • PSI

Available compounds

HF • CT

SBS 113

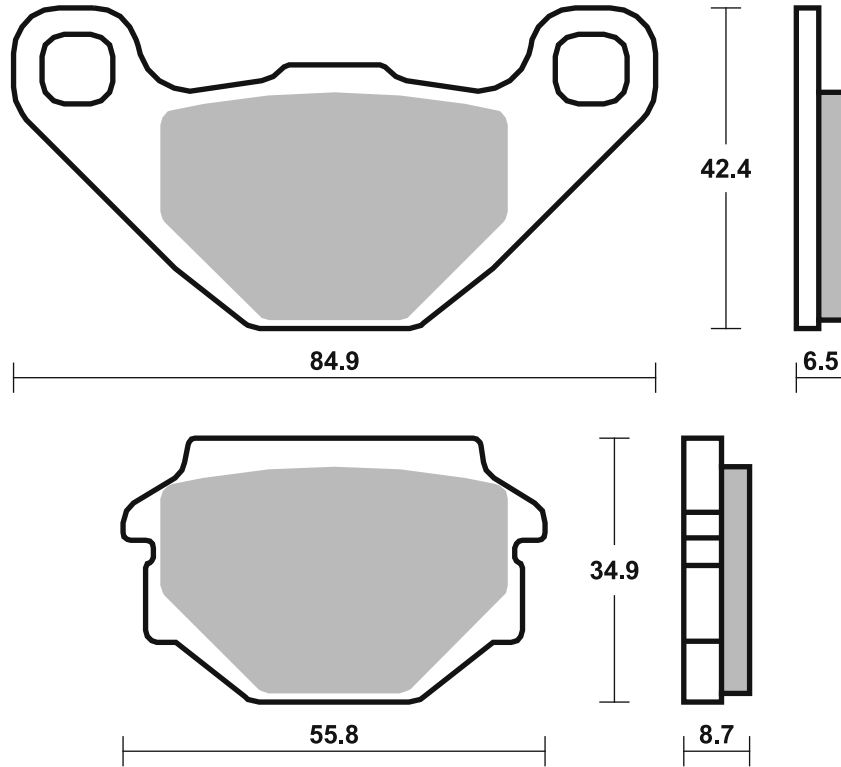

Available compounds

HF • CT

SBS 114

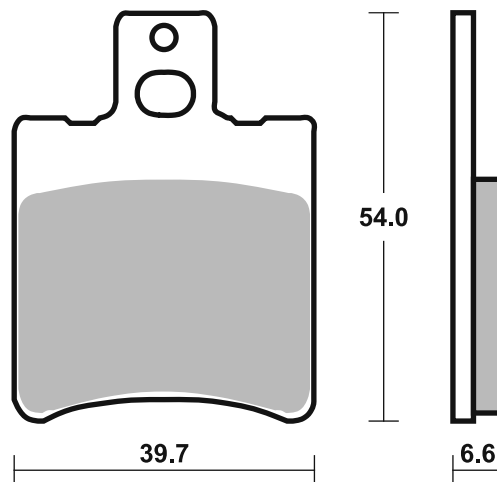



STREET  
AMERICAN  
SCOOTER

HF • HS • LS  
H.HF • H.CT • H.HS • H.LS  
HF • CT • MS

RACING  
OFF ROAD  
ATV

RST • DC • DCC • DS-1 • DS-2 • RQ  
SI • RSI • CS  
ATS • SI • RSI • PSI

Available compounds

HF • CT

SBS 115

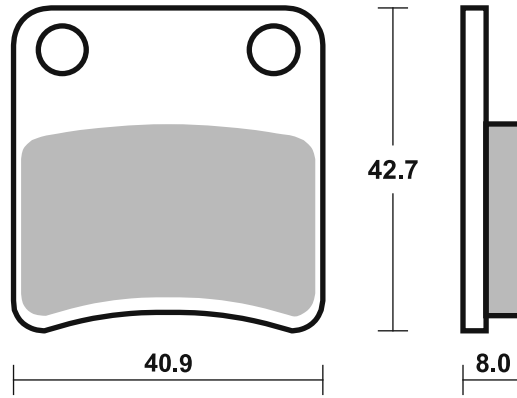

Available compounds

HF • CT

SBS 116

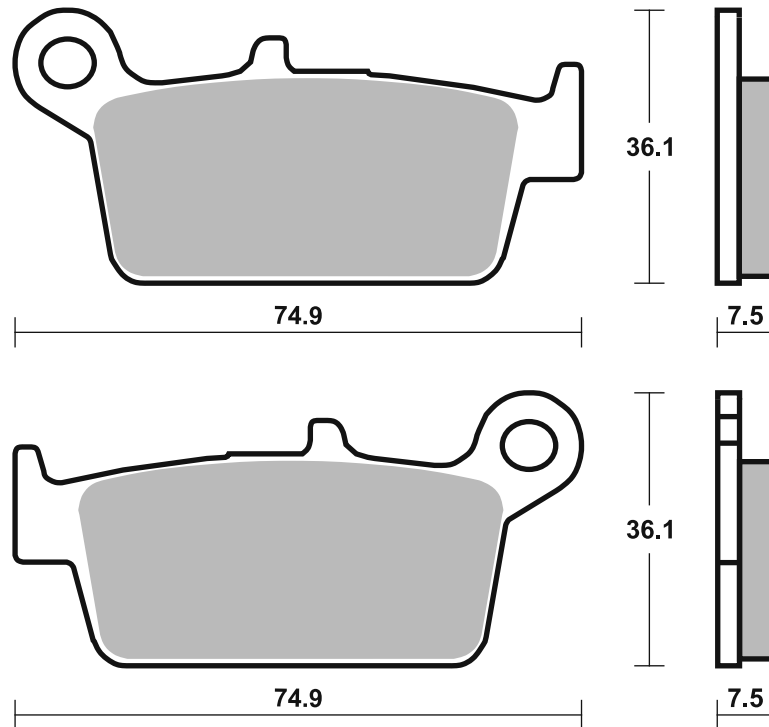



STREET  
AMERICAN  
SCOOTER

HF • HS • LS  
H.HF • H.CT • H.HS • H.LS  
HF • CT • MS

RACING  
OFF ROAD  
ATV

RST • DC • DCC • DS-1 • DS-2 • RQ  
SI • RSI • CS  
ATS • SI • RSI • PSI

Available compounds

HF • CT

SBS 117

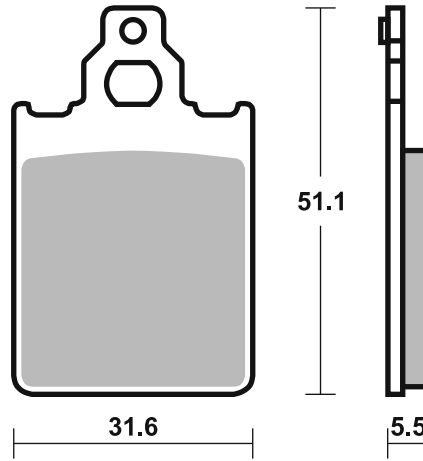

Available compounds

HF

SBS 118

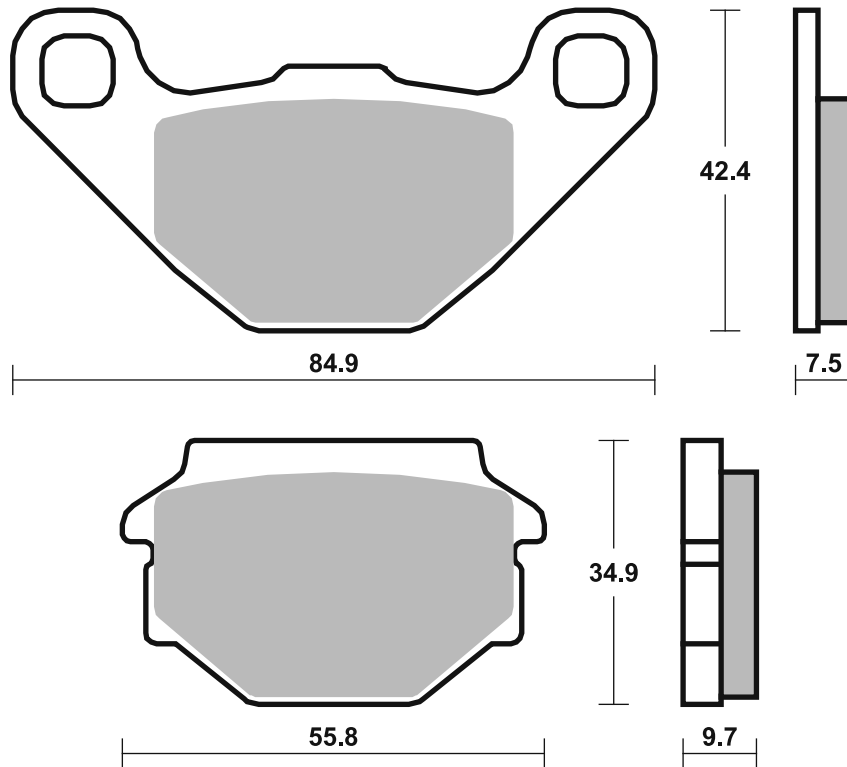



## Applications

### SBS 119

### Recommended compound



<b>AEON</b>			
125 Oz	14 - 14	<b>CT</b>	
125 Urban	14 - 14	<b>CT</b>	
400 Elite	14 - 15	<b>MS</b>	
<b>DAELIM</b>			
QL 125 Steezer	17 - 19	<b>CT</b>	
S 125 to VIN SDC007440	17 - 19	<b>CT</b>	
SV 125 S3	11 - 15	<b>CT</b>	
<b>HONDA</b>			
NS-1 75	92 - 00	<b>HF</b>	
NSR 80 R	93 - 95	<b>HF</b>	
NF 100 Supra	97 - 99	<b>HF</b>	
<b>ITALJET</b>			
50 Rollercraft	08 - 12	<b>HF</b>	
125 Torpedo	08 - 11	<b>CT</b>	
150 Torpedo	08 - 12	<b>CT</b>	
<b>KEEWAY</b>			
100 Partner	06 - 10	<b>HF</b>	
110 Partner	06 - 07	<b>HF</b>	
125 Speed	06 - 12	<b>CT</b>	
150 Speed	06 - 09	<b>CT</b>	
<b>KYMCO</b>			
50 B&W	04 - 06	<b>HF</b>	
50 Dink, Dink Sport, B&W	99 - 02	<b>HF</b>	
50 K-Pipe	12 - 13	<b>HF</b>	
50 New Dink	08 - 13	<b>HF</b>	



<b>KYMCO</b>			
50 Spacer	99 - 06	<b>HF</b>	
50 Super-9 A/C	02 - 07	<b>HF</b>	
50 Super-9 L/C	02 - 07	<b>HF</b>	
50 Yager	01 - 07	<b>HF</b>	
100 Cobra Racer	99 - 03	<b>HF</b>	
125 Agility 16+	14 - 16	<b>CT</b>	
125 B&W, Dink Sport	99 - 06	<b>CT</b>	<b>CT</b>
125 Cruiser	99 - 99	<b>CT</b>	
125 Dink	96 - 09	<b>CT</b>	<b>CT</b>
125 Grand Dink	02 - 07	<b>CT</b>	<b>CT</b>
125 Movie	99 - 08	<b>CT</b>	
125 Movie XL	01 - 09	<b>CT</b>	
125 New Dink	08 - 10	<b>CT</b>	<b>CT</b>
125 Quannon	08 - 12	<b>CT</b>	<b>CT</b>
125 Spacer	99 - 03	<b>CT</b>	<b>CT</b>
125 Techno GT	06 - 10	<b>CT</b>	
125 Yager	01 - 07	<b>CT</b>	<b>CT</b>
125 Yager GT	09 - 09	<b>CT</b>	
150 B&W	01 - 05	<b>CT</b>	<b>CT</b>
150 Dink	99 - 04	<b>CT</b>	<b>CT</b>
150 Grand Dink	02 - 11	<b>CT</b>	<b>CT</b>
150 Movie XL	01 - 09	<b>CT</b>	
150 Quannon	10 - 14	<b>CT</b>	<b>CT</b>
150 Spacer	99 - 04	<b>CT</b>	<b>CT</b>
150 Yager	01 - 05	<b>CT</b>	<b>CT</b>
150 Zing	99 - 13	<b>CT</b>	
200 Agility 16+	14 - 17	<b>CT</b>	
200 Agility R16	11 - 15	<b>CT</b>	
200 Dink	04 - 12	<b>CT</b>	<b>CT</b>
200 i New Dink	08 - 12	<b>CT</b>	<b>CT</b>
200 Like i	10 - 16	<b>CT</b>	<b>CT</b>



<b>KYMCO</b>			
200 Yager	04 - 13	<b>CT</b>	<b>CT</b>
250 B&W, Dink Sport	01 - 06	<b>MS</b>	<b>MS</b>
250 People	03 - 12	<b>MS</b>	
250 Yup	03 - 05	<b>MS</b>	<b>MS</b>
300 People Si	08 - 10	<b>CT</b>	
<b>SYM</b>			
RS 125	05 - 06		<b>CT</b>
RS 150	05 - 06		<b>CT</b>

### SBS 120

### Recommended compound



<b>APRILIA</b>			
MX 50	03 - 10	<b>HF</b>	
RS 50 , Replica	00 - 05	<b>HF</b>	
RX 50	90 - 05	<b>HF</b>	
RX 50 Racing	04 - 06	<b>HF</b>	
ETX 125	92 - 99	<b>CT</b>	
<b>BENELLI</b>			
400 Velvet Dusk	03 - 04	<b>CT</b>	
<b>BETA</b>			
RR 50 Enduro Alu	04 - 07	<b>HF</b>	
RR 50 Supermotard Alu	04 - 05	<b>HF</b>	
<b>CPI</b>			
50 GTR	02 - 02	<b>HF</b>	
50 GTS	02 - 03	<b>HF</b>	
125 GTR, GTS	02 - 03	<b>CT</b>	
200 GTR, GTS	02 - 03	<b>CT</b>	
<b>FACTORY</b>			
RP 50 Desert	04 - 04	<b>HF</b>	
SM 50 Chrono	04 - 04	<b>HF</b>	
SP 50 Chrono	04 - 04	<b>HF</b>	
YR 50 Desert	04 - 04	<b>HF</b>	
<b>GILERA</b>			
50 DNA	01 - 07	<b>HF</b>	
125 DNA	01 - 03	<b>CT</b>	
FX 125 Runner (Grimeca cal.)	00 - 05	<b>CT</b>	



<b>GILERA</b>			
FX 125 Runner SP (Grimeca cal.)	00 - 03	<b>CT</b>	
VX 125 Runner 4T (Grimeca cal.)	01 - 12	<b>CT</b>	
175 Mad Mud	02 - 02	<b>CT</b>	
180 DNA	01 - 03	<b>CT</b>	
FXR 180 Runner	98 - 99	<b>CT</b>	
FXR 180 Runner (Grimeca cal.)	00 - 03	<b>CT</b>	
FXR 180 Runner SP (Grimeca cal.)	00 - 00	<b>CT</b>	
VXR 180 Runner 4T (Grimeca cal.)	01 - 08	<b>CT</b>	
FX 200 Runner SP	98 - 01	<b>CT</b>	
VXR 200 Runner 4T (Grimeca cal.)	01 - 09	<b>CT</b>	
<b>MALAGUTI</b>			
XSM 50	03 - 14	<b>HF</b>	
XSM 50	19 - 23	<b>HF</b>	
XTM 50	19 - 23	<b>HF</b>	
R 125 Madison	99 - 09	<b>CT</b>	
150 Madison	99 - 03	<b>CT</b>	
180 Madison	02 - 02	<b>CT</b>	
S 200 Madison	03 - 06	<b>CT</b>	
<b>PIAGGIO VESPA</b>			
GTX 125 SuperHexagon (Grimeca cal.) (11" wheels)	00 - 00	<b>CT</b>	
LX 125 Hexagon	99 - 00	<b>CT</b>	
LX4 125 Hexagon	99 - 07	<b>CT</b>	
GTX 180 SuperHexagon (Grimeca cal.) (11" wheels)	00 - 00	<b>CT</b>	
LXT 180 Hexagon	99 - 00	<b>CT</b>	
GT 250 Hexagon	99 - 03	<b>MS</b>	
GTX 250 Super Hexagon	01 - 02	<b>MS</b>	
<b>RIEJU</b>			
RS1 50 , Castrol	01 - 03	<b>HF</b>	



<b>PIAGGIO VESPA</b>			
LX 125 Skipper, ST	99 - 04	<b>CT</b>	
LX4 125 Hexagon	99 - 07	<b>CT</b>	
GTX 180 SuperHexagon (Grimeca cal.) (11" wheels)	00 - 00	<b>CT</b>	
LXT 180 Hexagon	99 - 00	<b>CT</b>	
GT 250 Hexagon	99 - 03	<b>MS</b>	
GTX 250 Super Hexagon	01 - 02	<b>MS</b>	
<b>RIEJU</b>			
RS1 50 , Castrol	01 - 03	<b>HF</b>	

STREET  
AMERICAN  
SCOOTER

HF • HS • LS  
H.HF • H.CT • H.HS • H.LS  
HF • CT • MS

RACING  
OFF ROAD  
ATV

RST • DC • DCC • DS-1 • DS-2 • RQ  
SI • RSI • CS  
ATS • SI • RSI • PSI

Drawings 1:1

Available compounds

HF • CT • MS

SBS 119

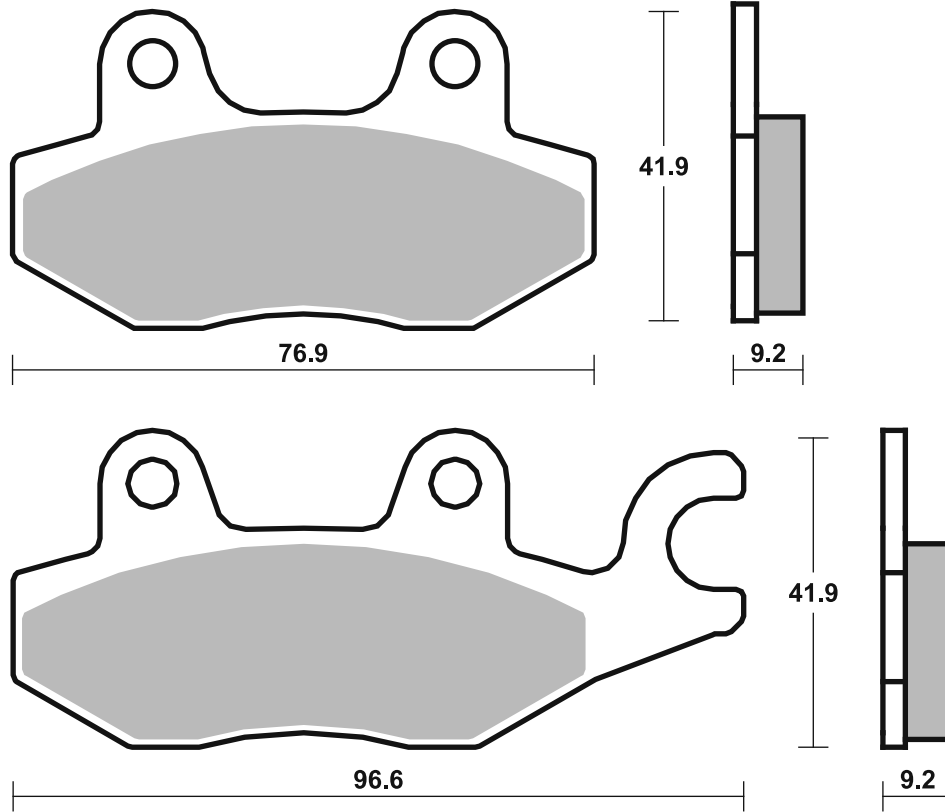

Available compounds

HF • CT • MS

SBS 120

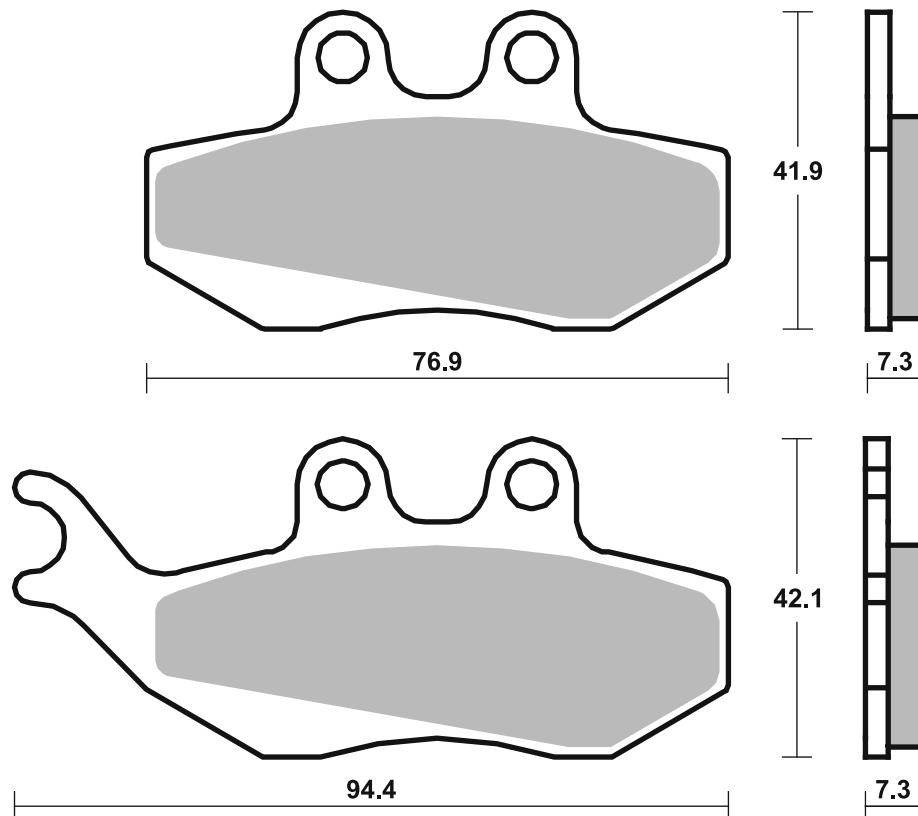

Dimensions in mm / Dimensions en mm  
1" = 25.4 mm, 1 mm = 0.04"

## Applications

### SBS 121

### Recommended compound



<b>DAELIM</b>			
	50 Besbi	07 - 07	<b>HF</b>

<b>ENDRESS</b>			
EMR	50	95 - 95	<b>HF</b>

<b>HONDA</b>			
CRM	50	88 - 96	<b>HF</b>
NH	50 Lead	94 - 94	<b>HF</b>
	75 Yupy	90 - 95	<b>HF</b>
NS-1	75	92 - 00	<b>HF</b>
NSR	80 R	87 - 95	<b>HF</b>
NH	90 Yupy	90 - 94	<b>HF</b>
NS	150	92 - 95	<b>HF</b>

<b>ITALJET</b>			
	125 Amarcord	08 - 16	<b>HF</b>

<b>KYMCO</b>			
	50 Cobra Cross	01 - 06	<b>HF</b>
	50 Cobra Exclusive	01 - 04	<b>HF</b>
	50 Cobra Racer	01 - 04	<b>HF</b>
	50 Easy	01 - 01	<b>HF</b>
	50 Filly LX	01 - 01	<b>HF</b>
	50 Heroism	95 - 96	<b>HF</b>
	50 Scout	95 - 00	<b>HF</b>
	50 Topboy on/off road	96 - 05	<b>HF</b>
	50 Topboy Racer/Cross	01 - 05	<b>HF</b>
	50 Yup	01 - 01	<b>HF</b>
CX	50 Curio Super	94 - 97	<b>HF</b>
DD	50 Sniper	94 - 96	<b>HF</b>
K12	50	95 - 00	<b>HF</b>



<b>KYMCO</b>			
KB	50	95 - 00	<b>HF</b>
ZX	50 Fever	96 - 01	<b>HF</b>
	100 Topboy on/off road	99 - 00	<b>HF</b>
KB	100	99 - 00	<b>HF</b>
	150 Freeway	95 - 00	<b>HF</b>

<b>PEUGEOT</b>			
SV	50 Geo	93 - 99	<b>HF</b>
SV	50 L	93 - 93	<b>HF</b>
SV	80 Geo	93 - 98	<b>HF</b>
SV	125 C Executive	96 - 98	<b>HF</b>
SV	125 Executive	94 - 95	<b>HF</b>
SV	125 Geo	93 - 98	<b>HF</b>

### SBS 122

### Recommended compound



<b>SUZUKI</b>			
AN	50	95 - 95	<b>HF</b>
TR	50 Street Magic	97 - 00	<b>HF</b>
AH	100 V Adress	95 - 96	<b>HF</b>
UG	110 Hokuto	00 - 02	<b>HF</b>
UK	110 Adress	15 - 19	<b>HF</b>
	125 Vecstar	94 - 97	<b>CT</b>
AH	125 V Adress	95 - 95	<b>HF</b>
AN	125 R	94 - 05	<b>CT</b>
UC	125 Epicuro	99 - 02	<b>CT</b>
AN	150	98 - 01	<b>CT</b>
UC	150 Epicuro	99 - 02	<b>CT</b>
	250 Vecstar	94 - 94	<b>CT</b>

STREET  
AMERICAN  
SCOOTER

HF • HS • LS  
H.HF • H.CT • H.HS • H.LS  
HF • CT • MS

RACING  
OFF ROAD  
ATV

RST • DC • DCC • DS-1 • DS-2 • RQ  
SI • RSI • CS  
ATS • SI • RSI • PSI

Available compounds

HF

SBS 121

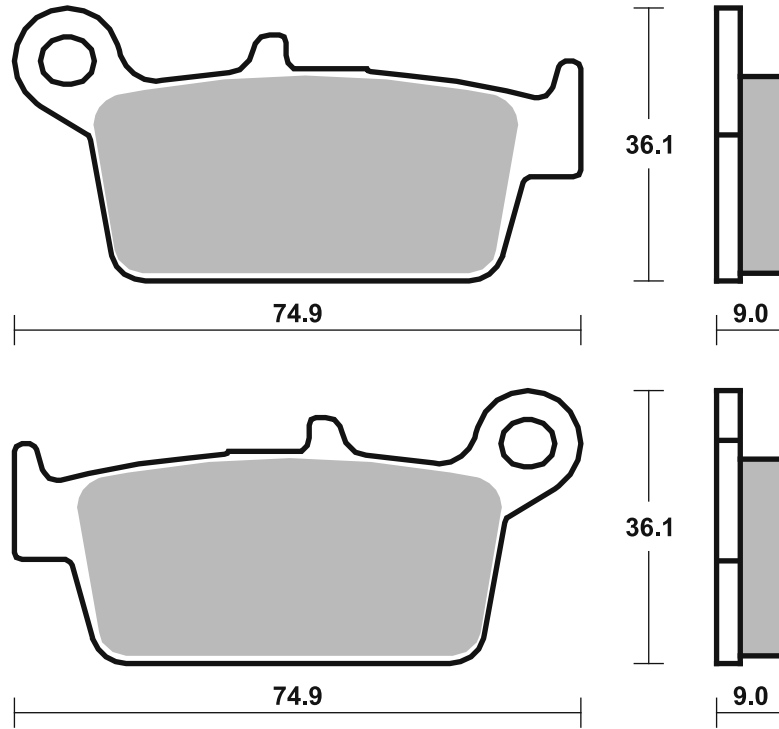

Available compounds

HF • CT

SBS 122

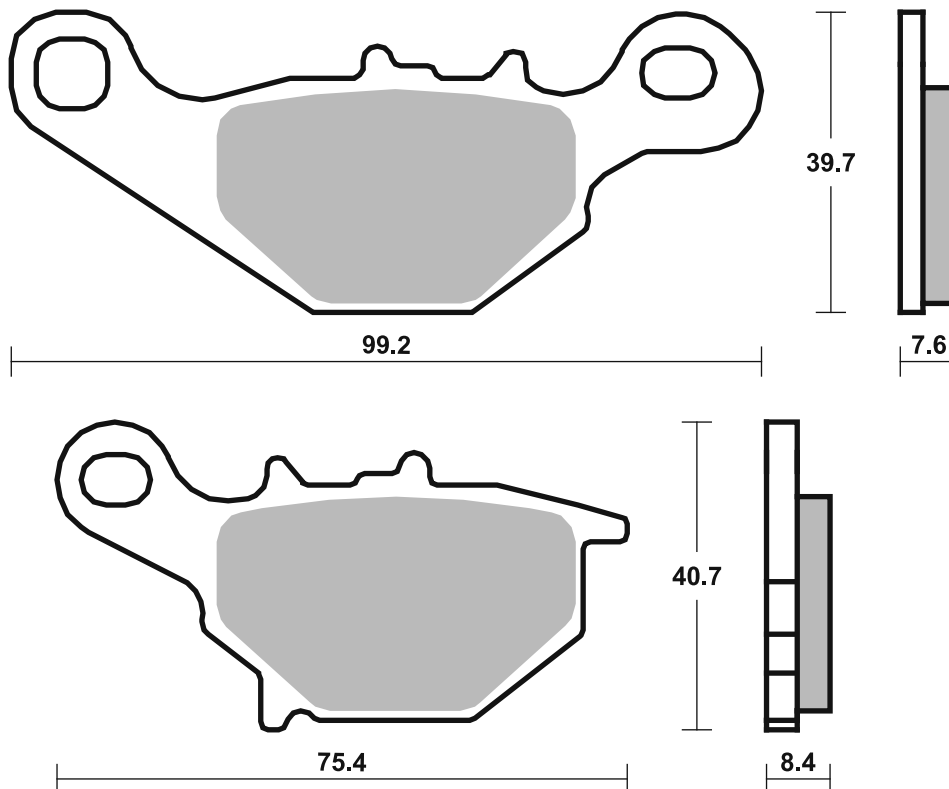



<b>APRILIA</b>			
50 Amico, Scooter	92 - 92	HF	
50 Amico, GL, GLE	93 - 98	HF	
50 Business	97 - 98	HF	
50 Classic	96 - 99	HF	
50 Club	97 - 99	HF	
50 Gulliver	96 - 00	HF	
50 McGulliver	00 - 00	HF	
50 Rally	95 - 01	HF	
50 Scarabeo Ditech	02 - 06	HF	
50 Scarabeo Street	00 - 06	HF	
50 Scarabeo,			
2nd series	94 - 99	HF	
50 Sonic, GP	99 - 09	HF	
50 Younger	97 - 97	HF	
AC 50 Rally	95 - 02	HF	
LC 50 Rally	96 - 01	HF	HF
SR 50 Ditech	01 - 06	HF	
SR 50 Racing	00 - 04	HF	
SR 50 Replica			
(Liquid Cooled)	96 - 96	HF	
SR 50 Stealth, Racing	97 - 00	HF	HF
SR 50 Street	05 - 12	HF	
125 Leonardo	96 - 96	CT	
<b>ATALA</b>			
25 Carosello	97 - 97	HF	
50 Carosello	97 - 01	HF	
50 Hacker	95 - 00	HF	
125 Hacker	98 - 98	CT	
<b>BENELLI</b>			
50 Chrono	94 - 94	HF	
50 Nemo, Quadra	94 - 94	HF	
50 Pepe	99 - 11	HF	
491 50 GT, Sport	98 - 99	HF	
491 50 Naked	99 - 02	HF	
491 50 Racing	99 - 04	HF	HF
491 50 RR, -GP	00 - 02	HF	HF
491 50 ST	01 - 02	HF	
491 50 Superbike	99 - 04	HF	HF
K2 50 Air	98 - 01	HF	HF
K2 50 LC	99 - 01	HF	HF
K2 50 Namur	99 - 99	HF	HF
100 Naked	02 - 03	HF	
K2 100 Biposto	99 - 01	HF	
LX 100 Pepe	02 - 06	HF	
125 Adiva	00 - 05	CT	
125 Velvet,			
Velvet Touring	99 - 99	CT	
150 Adiva	00 - 05	CT	
150 Velvet,			
Velvet Touring	00 - 12	CT	
250 Velvet,			
Velvet Touring	99 - 08	CT	
400 Velvet Dusk	03 - 04		CT
<b>BETA</b>			
50 Ark AirCooled	99 - 12	HF	
50 Ark K Series	97 - 05	HF	HF
50 Ark LC	99 - 12	HF	HF
50 Chrono 13	94 - 99	HF	
50 Eikon	04 - 07	HF	
50 Quadra	95 - 96	HF	
50 Tempo	99 - 99	HF	
50 Tempo (13" wheels)	00 - 02	HF	
50 Tempo (16" wheels)	00 - 02	HF	
125 Eikon	04 - 06	CT	
150 Eikon	04 - 04	CT	



<b>CPI</b>			
50 GTR	03 - 09		HF
<b>DERBI</b>			
50 Vamos R			
(Brema cal.)	95 - 95	HF	
<b>GARELLI</b>			
50 Flo'	00 - 02	HF	
125 Panther	02 - 02		CT
150 Panther	02 - 02		CT
250 Panther	02 - 02		CT
<b>GENERIC</b>			
50 Toxic	07 - 16		HF
50 Trigger SM	06 - 14		HF
50 Trigger SM			
Competition	08 - 14		HF
50 Trigger X	06 - 14		HF
50 Trigger X			
Competition	08 - 12		HF
<b>GILERA</b>			
50 Eaglet	97 - 99		HF
50 Ice	02 - 05		HF
50 Stalker	97 - 01		HF
DT 50 Stalker	01 - 05		HF
NRG 50	94 - 95		HF
70 Runner Malossi	98 - 98		HF
200 Stalker	97 - 01		CT
<b>HERCULES</b>			
50 Gipsy, Splinter,			
Reggae	95 - 95		HF
<b>HONDA</b>			
50 Formula	94 - 98		HF
50 Sky Classic	00 - 03		HF
50 Sky Vetro	00 - 02		HF
SFX 50 Sport	96 - 04		HF
SGX 50 Sky DX	97 - 03		HF
SH 50 Fifty, Scoopy	00 - 03		HF
SH 50 T	97 - 97		HF
SXR 50	98 - 00		HF
SZX 50 X8R-S	98 - 04		HF
SZX 50 X8R-X	98 - 01		HF
<b>HYOSUNG</b>			
125 Boomer	03 - 03		CT
125 Exceed	02 - 06		CT
125 Grand Prix	98 - 04		CT
125 Hyper	99 - 09		CT
GPS 125 D	00 - 03		CT
150 Exceed	02 - 04		CT
150 Grand Prix	98 - 01		CT
<b>ITALJET</b>			
50 Formula	94 - 00		HF
80 Formula	94 - 97		HF
125 Formula	94 - 03		CT
<b>KEEWAY</b>			
125 Arn	06 - 08		CT
150 Arn	06 - 08		CT
<b>MACAL</b>			
50 Flash	99 - 99		HF
<b>MALAGUTI</b>			
50 Ciak	00 - 09		HF
50 Ciak Twin Disk	02 - 09		HF



<b>MALAGUTI</b>			
50 Yesterday	97 - 02		HF
EL 50 Crosser	97 - 00		HF
F-10 50 Jet-Line	94 - 98		HF
F-10 50 Timemachine	03 - 09		HF
F-10 50 WAP	02 - 09		HF
F-12 50 Phantom A.C.	99 - 03		HF
F-12 50 Phantom Digit	02 - 10		HF
F-12 50 Phantom L.C. dd	99 - 09		HF
F-12 50 Racing Life	03 - 09		HF
F-12 50 Tyre Track	03 - 09		HF
F-15 50 Mechatronic	03 - 08		HF
SL 50 Centro	96 - 00		HF
100 Ciak	00 - 01		HF
F-12 100 Phantom A.C.	00 - 03		HF
F-12 100 Phantom Twin Disk	02 - 03		HF
125 Ciak, Ciak Master	02 - 06		CT
F-18 125 , Warrior	00 - 02		CT
150 Ciak, Ciak Master	02 - 08		CT
F-18 150	00 - 03		CT
<b>MBK</b>			
50 Booster 12"	03 - 10		HF
50 Booster Naked	04 - 16		HF
50 Booster Spirit	00 - 16		HF
50 Flipper	99 - 04		HF
50 Mach G	02 - 03		HF
100 Nitro	00 - 03		HF
YN 100 Ovetto	00 - 02		HF
125 Doodo	01 - 05		CT
150 Doodo	01 - 01		CT
<b>MOTRON</b>			
50 Spike	97 - 98		HF
50 Sting	95 - 98		HF
50 Syncro	97 - 98		HF
50 Thunder	95 - 98		HF
<b>PEUGEOT</b>			
50 Buxy (Brema cal.)	94 - 97		HF
50 Speedake			
(Brema cal.)	94 - 01		HF
50 Speedflight LC,			
(Brema cal.)	96 - 15		HF
50 Zenith Luxe	94 - 00		HF
<b>PROTOS</b>			
50 Ellisse Scooter car	98 - 98		HF
<b>QUADRO</b>			
D 350	11 - 15		CT
<b>SIAM</b>			
50 Falcon	97 - 97		HF
50 Scross	97 - 97		HF
<b>SUZUKI</b>			
AY 50 W	00 - 04		HF
AY 50 WR	00 - 05		HF
<b>TOMOS</b>			
50 Revival	02 - 04		HF
50 Streetmate	03 - 05		HF
<b>YAMAHA</b>			
50 Jog R/RR	02 - 18		HF
50 Neo's 4	09 - 19		HF
50 Why	99 - 07		HF
BW 50 Bump	97 - 02		HF
BW 50 Next Generation	96 - 07		HF
BW 50 Sports Spec R	02 - 06		HF



STREET  
AMERICAN  
SCOOTER

HF • HS • LS  
H.HF • H.CT • H.HS • H.LS  
HF • CT • MS

RACING  
OFF ROAD  
ATV

RST • DC • DCC • DS-1 • DS-2 • RQ  
SI • RSI • CS  
ATS • SI • RSI • PSI

Available compounds

**HF • CT**

**SBS 123**

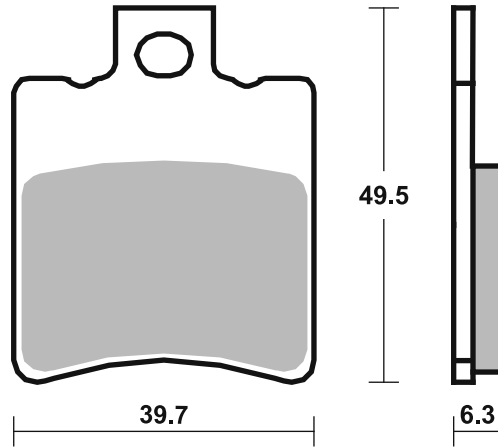



STREET  
AMERICAN  
SCOOTER

HF • HS • LS  
H.HF • H.CT • H.HS • H.LS  
HF • CT • MS

RACING  
OFF ROAD  
ATV

RST • DC • DCC • DS-1 • DS-2 • RQ  
SI • RSI • CS  
ATS • SI • RSI • PSI

Available compounds

HF • CT

SBS 123

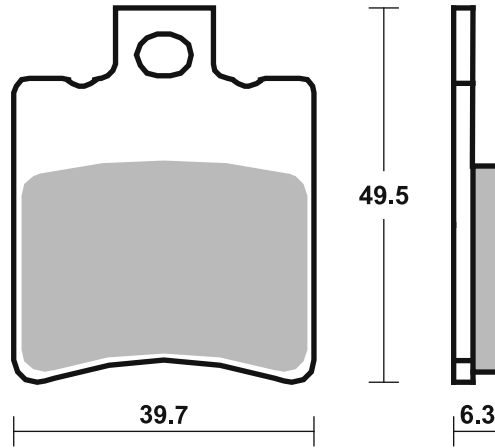

Available compounds

HF • CT

SBS 124

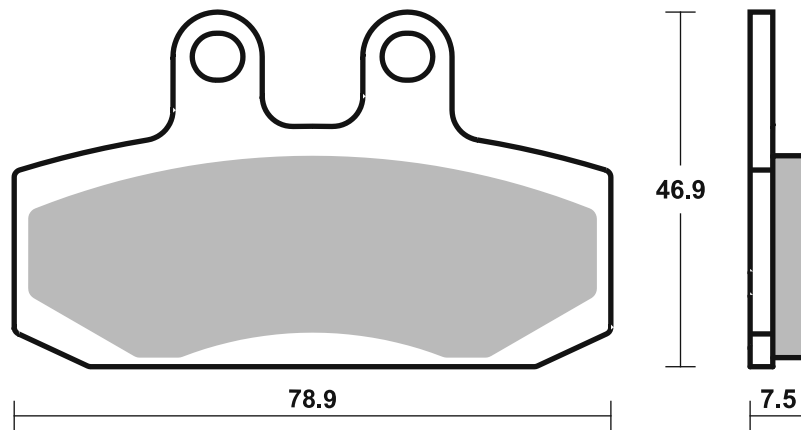

Available compounds

HF • CT • MS

SBS 125

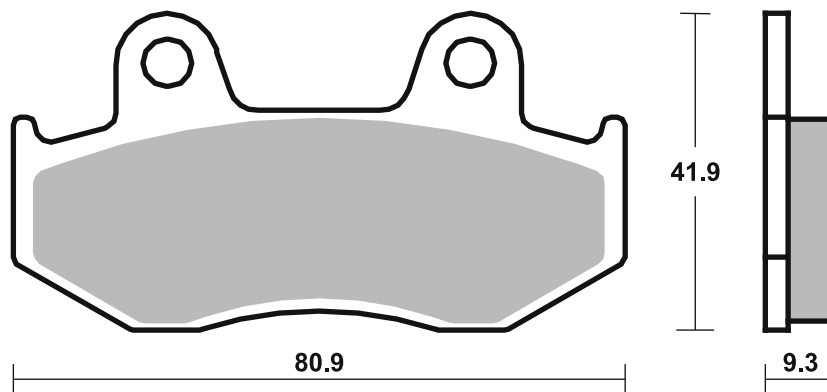



STREET  
AMERICAN  
SCOOTER

HF • HS • LS  
H.HF • H.CT • H.HS • H.LS  
HF • CT • MS

RACING  
OFF ROAD  
ATV

RST • DC • DCC • DS-1 • DS-2 • RQ  
SI • RSI • CS  
ATS • SI • RSI • PSI

Available compounds

HF • CT

SBS 126

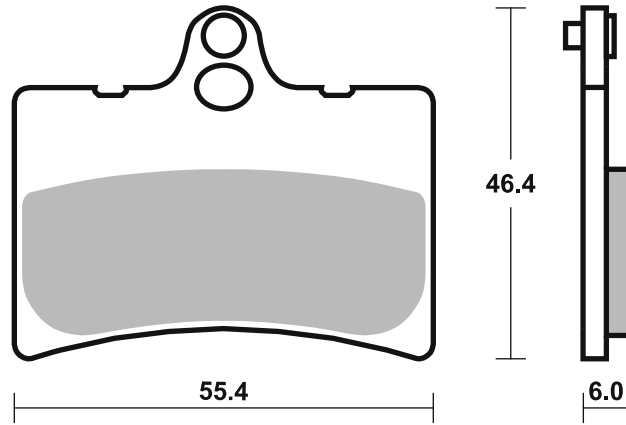

Available compounds

HF • CT

SBS 127

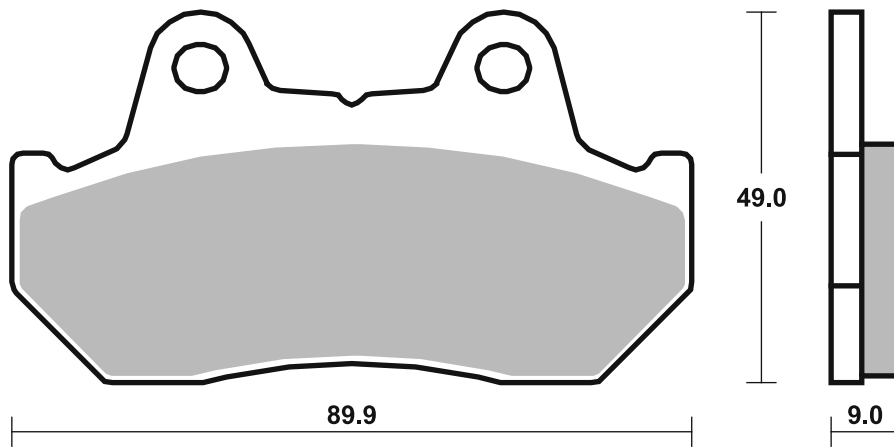

Available compounds

HF • CT • MS

SBS 128

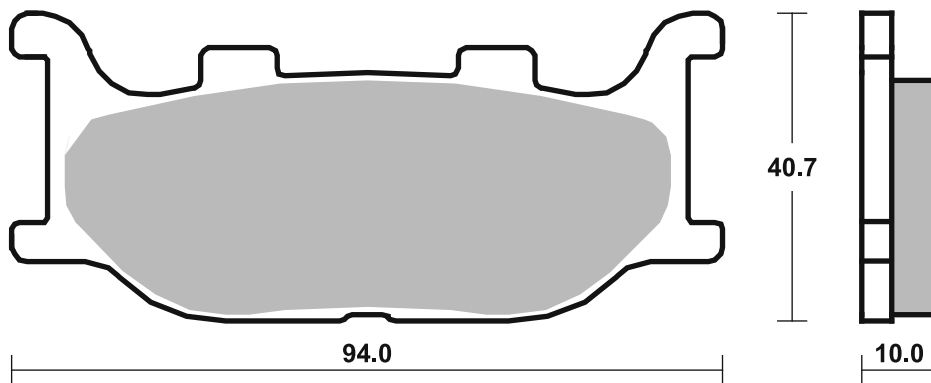





STREET  
AMERICAN  
SCOOTER

HF • HS • LS  
H.HF • H.CT • H.HS • H.LS  
HF • CT • MS

RACING  
OFF ROAD  
ATV

RST • DC • DCC • DS-1 • DS-2 • RQ  
SI • RSI • CS  
ATS • SI • RSI • PSI

Available compounds

HF • CT

SBS 129

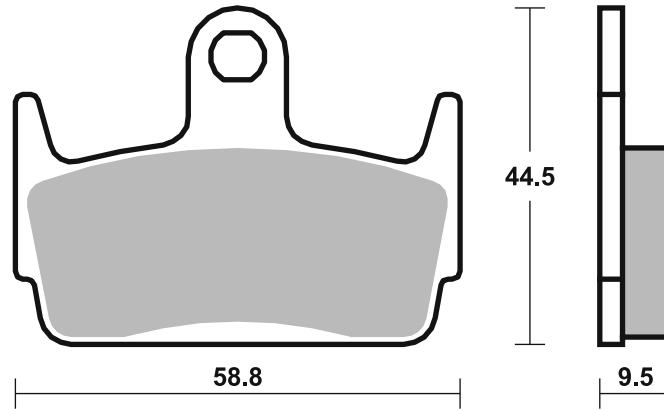

Available compounds

HF • CT

SBS 130

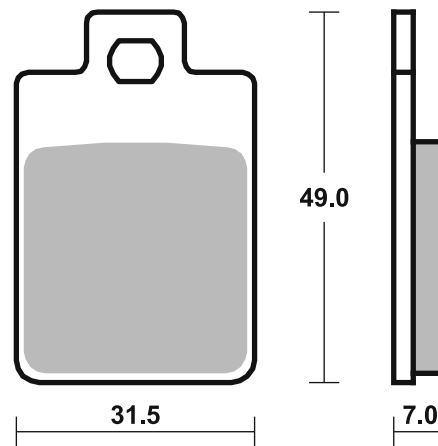

Available compounds

HF

SBS 131

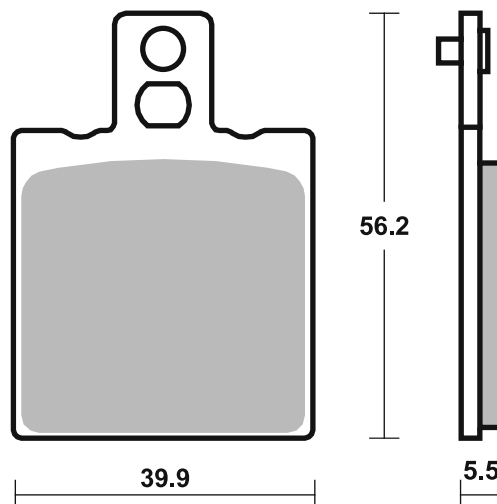



STREET  
AMERICAN  
SCOOTER

HF • HS • LS  
H.HF • H.CT • H.HS • H.LS  
HF • CT • MS

RACING  
OFF ROAD  
ATV

RST • DC • DCC • DS-1 • DS-2 • RQ  
SI • RSI • CS  
ATS • SI • RSI • PSI

Available compounds

HF • CT

SBS 132

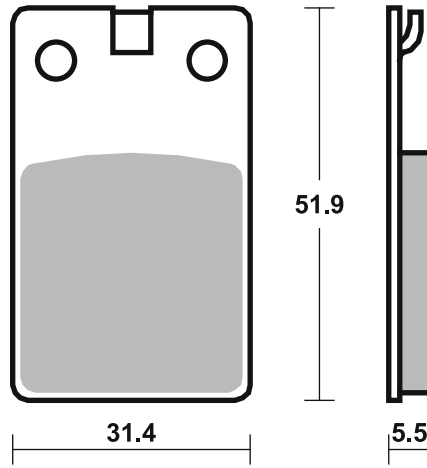

Available compounds

HF • CT

SBS 133

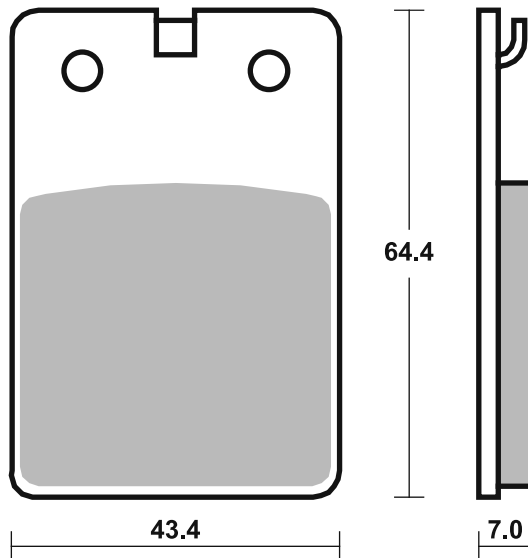

## Applications

### SBS 134 Recommended compound



<b>BENELLI</b>			
	125 Caffenero	08 - 11	<b>CT</b>
	250 Caffenero	08 - 14	<b>MS</b>
<b>DAYTONA</b>			
DY	125 RS Efi	17 - 21	<b>CT</b>
<b>KYMCO</b>			
S	250 People	06 - 08	<b>MS</b>
<b>PIAGGIO VESPA</b>			
	300 Beverly hpe	22 - 22	<b>MS</b>
<b>SUZUKI</b>			
UH	125 Burgman	15 - 19	<b>CT</b>
UH	200 Burgman	14 - 18	<b>CT</b>
AN	400 Burgman	07 - 24	<b>MS</b>
<b>YAMAHA</b>			
TZM	50 R	94 - 97	<b>HF</b>
TZR	50	90 - 02	<b>HF</b>

### SBS 135 Recommended compound



<b>PEUGEOT</b>			
	125 Django Allure	14 - 16	<b>CT</b>
	125 Django Evasion	14 - 16	<b>CT</b>
	125 Django Sport	14 - 16	<b>CT</b>
	125 Pulsion Active	19 - 22	<b>CT</b>
	125 Pulsion Allure	19 - 22	<b>CT</b>
	125 Pulsion RS	19 - 22	<b>CT</b>
	150 Django Allure	14 - 15	<b>CT</b>
	150 Django Evasion	14 - 15	<b>CT</b>
	150 Django Sport	14 - 15	<b>CT</b>
<b>SUZUKI</b>			
GSX-R	50	87 - 87	<b>HF</b>
OR	50 E	80 - 80	<b>HF</b>
RG	50 GAG	87 - 92	<b>HF</b>
RG	50 Gamma	90 - 96	<b>HF</b>
TV	50 Wolf	89 - 91	<b>HF</b>
ZR	50	81 - 87	<b>HF</b>
<b>SYM</b>			
	125 Husky	96 - 98	<b>CT</b>

Brake Pad 1:1 Drawings,  
Compounds, Fitments



STREET  
AMERICAN  
SCOOTER

HF • HS • LS  
H.HF • H.CT • H.HS • H.LS  
HF • CT • MS

RACING  
OFF ROAD  
ATV

RST • DC • DCC • DS-1 • DS-2 • RQ  
SI • RSI • CS  
ATS • SI • RSI • PSI

Drawings 1:1

Available compounds

HF • CT • MS

SBS 134

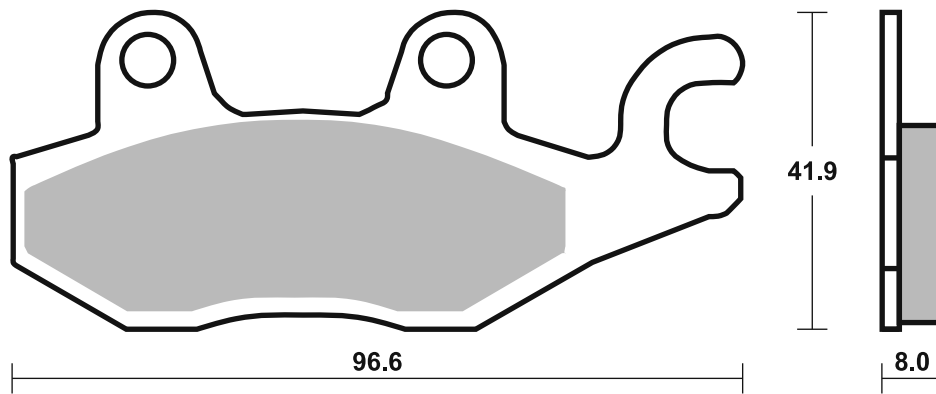
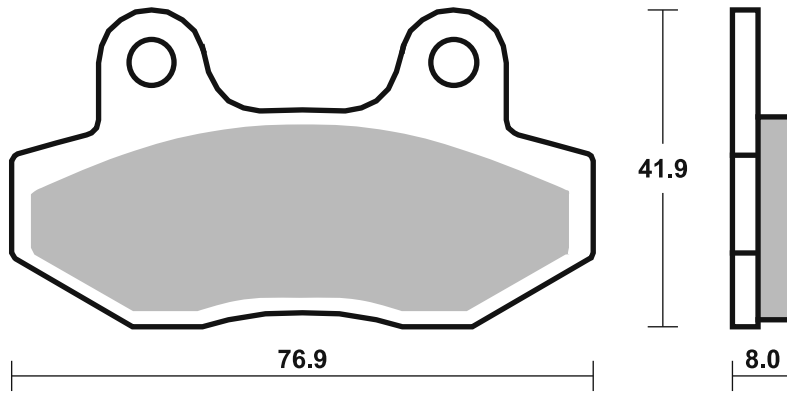

Available compounds

HF • CT

SBS 135

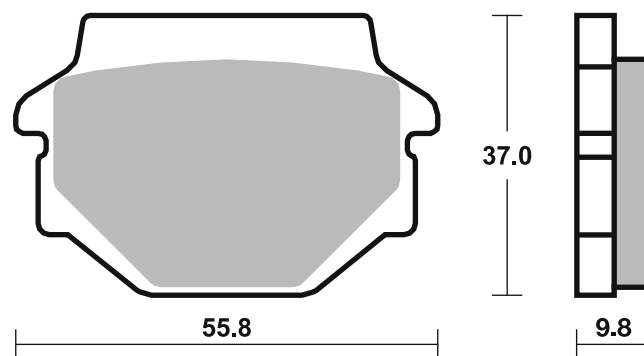
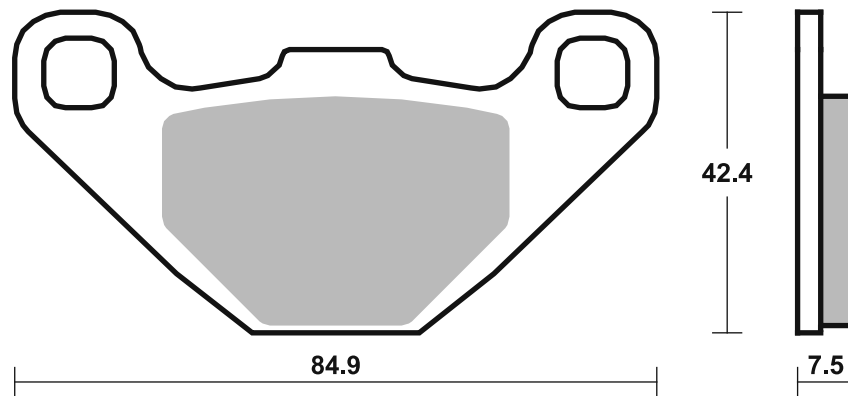



STREET  
AMERICAN  
SCOOTER

HF • HS • LS  
H.HF • H.CT • H.HS • H.LS  
HF • CT • MS

RACING  
OFF ROAD  
ATV

RST • DC • DCC • DS-1 • DS-2 • RQ  
SI • RSI • CS  
ATS • SI • RSI • PSI

Available compounds

HF • CT

SBS 136

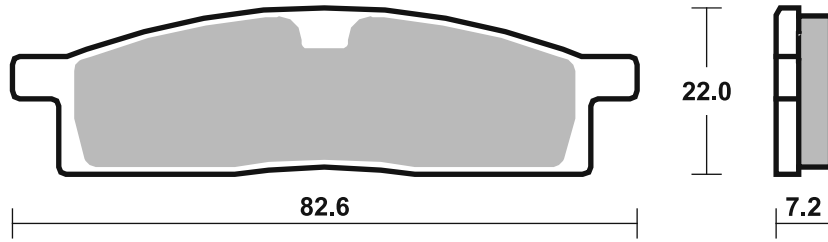

Available compounds

HF • CT

SBS 137

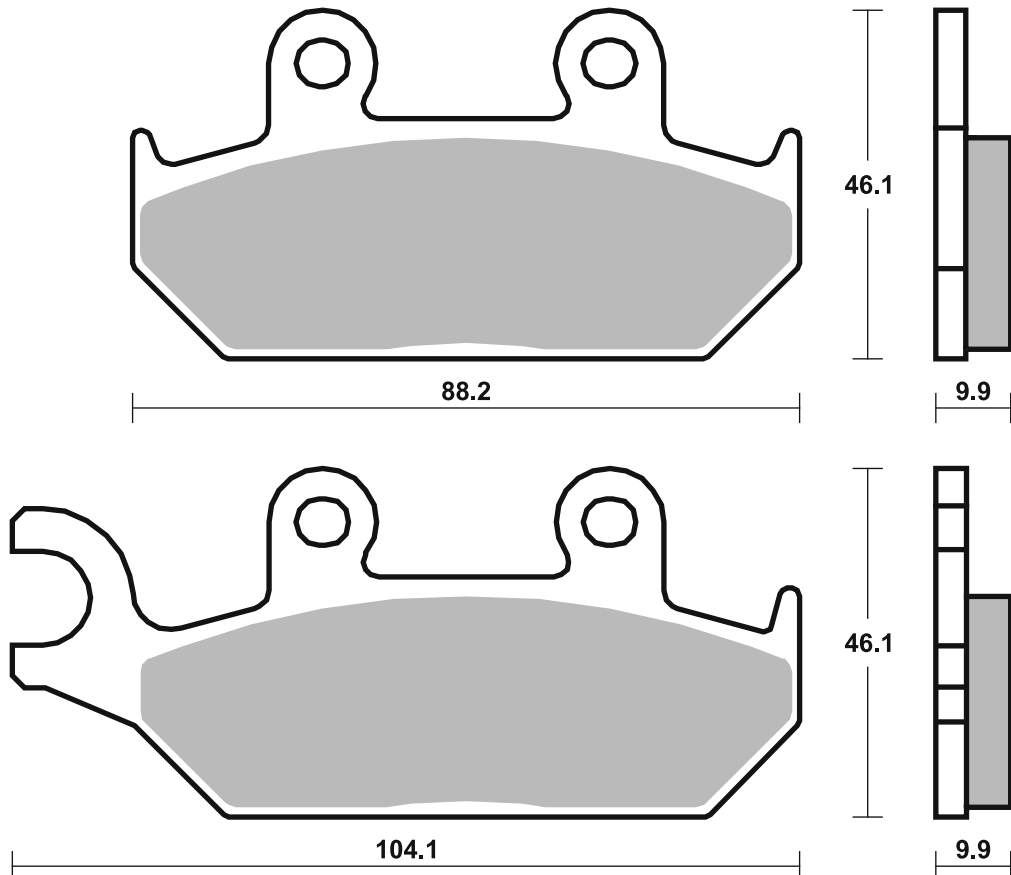



STREET  
AMERICAN  
SCOOTER

HF • HS • LS  
H.HF • H.CT • H.HS • H.LS  
HF • CT • MS

RACING  
OFF ROAD  
ATV

RST • DC • DCC • DS-1 • DS-2 • RQ  
SI • RSI • CS  
ATS • SI • RSI • PSI

Available compounds

HF • CT

SBS 138

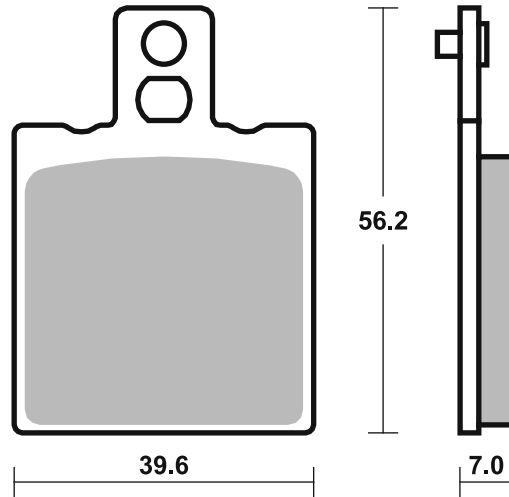

Available compounds

HF

SBS 139

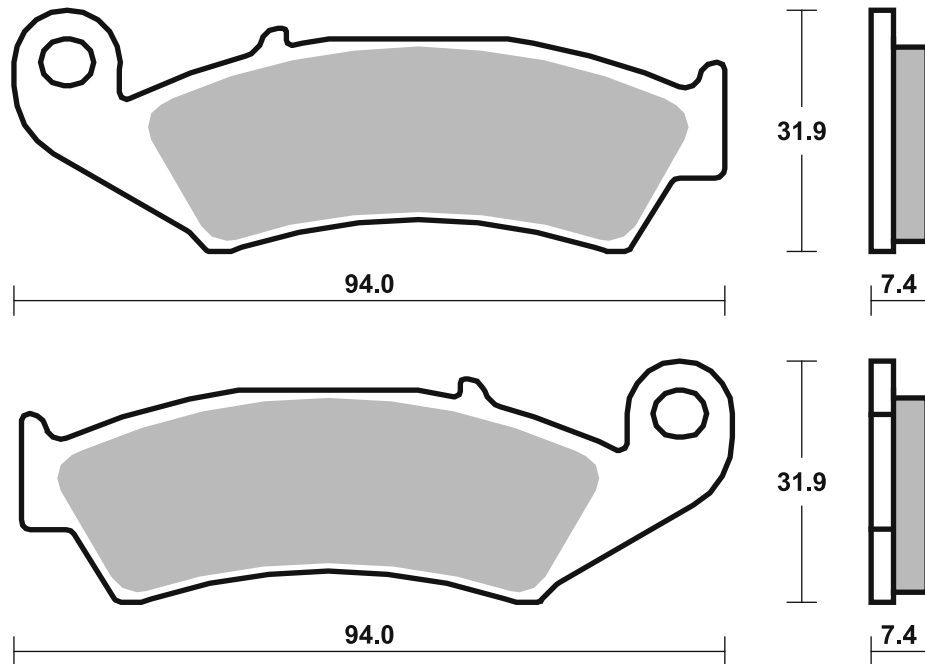



## Applications

### SBS 140

#### Recommended compound



<b>CAGIVA</b>			
	50 City	95 - 97	<b>HF</b>
<b>GARELLI</b>			
KRS	50	02 - 02	<b>HF</b>
PMX	50 Sport	00 - 00	<b>HF</b>
	125 Freeland	02 - 02	<b>CT</b>
	125 T-Rex	00 - 00	<b>CT</b>
	150 Freeland	02 - 02	<b>CT</b>
<b>LAMBRETTA</b>			
V	50 Special	21 - 23	<b>HF</b>
V	50 Special Flex	21 - 23	<b>HF</b>
V	125 Special	21 - 23	<b>CT</b>
V	125 Special Flex	21 - 23	<b>CT</b>
V	200 Special	21 - 23	<b>CT</b>
V	200 Special Flex	21 - 23	<b>CT</b>
<b>PEUGEOT</b>			
	50 Tweet	10 - 13	<b>HF</b>
	50 Tweet Evo	14 - 15	<b>HF</b>
	50 Tweet Evo RS	14 - 17	<b>HF</b>
	50 Tweet RS	10 - 13	<b>HF</b>
	125 Tweet	10 - 13	<b>CT</b>
	125 Tweet Evo	14 - 17	<b>HF</b>
	125 Tweet Evo RS	14 - 16	<b>HF</b>
	125 Tweet RS	10 - 13	<b>CT</b>
LXR	125	10 - 13	<b>CT</b>
	150 Tweet	10 - 13	<b>CT</b>
	150 Tweet RS	10 - 13	<b>CT</b>
LXR	200	10 - 11	<b>CT</b>
<b>PGO</b>			
	i-Dep	09 - 09	<b>HF</b>
	50 Dr. Big	01 - 06	<b>HF</b>
	50 G-Max	06 - 17	<b>HF</b>
	50 Libra	10 - 10	<b>HF</b>
	50 Ligerio	06 - 11	<b>HF</b>
	50 T-Rex	99 - 06	<b>HF</b>



<b>PGO</b>			
PMS	50	99 - 03	<b>HF</b>
PMX	50 Naked	06 - 08	<b>HF</b>
PMX	50 Sport	01 - 08	<b>HF</b>
	100 My Bubu	02 - 05	<b>HF</b>
	110 T-Rex	99 - 07	<b>HF</b>
	125 Charge A, B	02 - 02	<b>CT</b>
	125 Ligerio	06 - 11	<b>CT</b>
	125 My Bubu,		
	Young Bubu	02 - 05	<b>CT</b>
	125 T-Rex (2 stroke)	99 - 16	<b>CT</b>
	125 T-Rex (4 stroke)	99 - 02	<b>CT</b>
	150 TR3	02 - 04	<b>CT</b>
	150 T-Rex	01 - 06	<b>CT</b>
<b>SYM</b>			
	50 Allo	11 - 15	<b>HF</b>
	50 Crox	14 - 15	<b>CT</b>
	50 Fiddle	09 - 14	<b>HF</b>
	50 Fiddle III	16 - 19	<b>CT</b>
	50 Jet 4 Naked	11 - 13	<b>HF</b>
	50 Jet 4 R	11 - 13	<b>HF</b>
	50 Jet Basix	07 - 09	<b>HF</b>
	50 Jet Euro X	05 - 12	<b>HF</b>
	50 Jet Sport X	06 - 14	<b>HF</b>
	50 Jet Sport X SR	06 - 14	<b>HF</b>
	50 Jet, Alpha	95 - 97	<b>HF</b>
	50 Jungle	96 - 02	<b>HF</b>
	50 Mask	00 - 05	<b>HF</b>
	50 Mask LC	00 - 05	<b>HF</b>
	50 Orbit II	12 - 13	<b>HF</b>
	50 Red Devil	97 - 09	<b>HF</b>
	50 Super Fancy	95 - 97	<b>HF</b>
	50 Symphony	09 - 15	<b>HF</b>
	50 Symphony SR	11 - 15	<b>HF</b>
	50 Symphony ST	15 - 15	<b>CT</b>
	50 Symply	08 - 14	<b>HF</b>
	50 X'Pro	13 - 17	<b>HF</b>
	100 Jet	00 - 00	<b>HF</b>



<b>SYM</b>			
	100 Jet Euro X	05 - 05	<b>HF</b>
	100 Jet Sport X	05 - 05	<b>HF</b>
	100 Party	97 - 00	<b>HF</b>
	100 Super Fancy	95 - 00	<b>HF</b>
	110 Star	03 - 03	<b>HF</b>
	125 Allo	11 - 15	<b>CT</b>
	125 Citycom	09 - 14	<b>CT</b>
	125 Crox	14 - 15	<b>CT</b>
	125 Fiddle	09 - 16	<b>CT</b>
	125 Fiddle III	16 - 19	<b>CT</b>
	125 Jet 4	17 - 19	<b>CT</b>
	125 Jet 4	11 - 13	<b>HF</b>
	125 Jet X	24 - 24	<b>CT</b>
	125 Megalo	02 - 05	<b>CT</b>
	125 New Duke	02 - 07	<b>CT</b>
	125 Super Duke	95 - 01	<b>CT</b>
	125 Symphony	09 - 15	<b>CT</b>
	125 Symphony EX	17 - 17	<b>CT</b>
	125 Symphony S	11 - 17	<b>CT</b>
	125 Symphony SR	11 - 17	<b>CT</b>
	125 Symphony ST	15 - 19	<b>CT</b>
	125 Symply	08 - 14	<b>CT</b>
	125 X'Pro	14 - 16	<b>CT</b>
HD	125 Evo DT	10 - 10	<b>CT</b>
HD2	125 Evo	14 - 14	<b>CT</b>
	150 Attila	00 - 03	<b>CT</b>
	150 Crox	14 - 16	<b>CT</b>
	150 Jet 4	11 - 14	<b>HF</b>
	150 Super Duke	96 - 01	<b>CT</b>
	150 Symphony S	11 - 15	<b>CT</b>
	150 Symphony SR	11 - 15	<b>CT</b>
	200 Fiddle II	11 - 13	<b>CT</b>
	200 Fiddle III	16 - 19	<b>CT</b>
	200 Joyride Evo	09 - 15	<b>CT</b>
HD	200 Evo	07 - 13	<b>CT</b>
HD2	200 Evo	14 - 14	<b>CT</b>
	300 Citycom	09 - 15	<b>CT</b>
	300 Citycom S	15 - 17	<b>CT</b>

### SBS 141

#### Recommended compound



<b>BENELLI</b>			
	50 49X (Quattro Nove)	08 - 13	<b>HF</b>
<b>CAGIVA</b>			
	50 Nag	08 - 08	<b>HF</b>
<b>CPI</b>			
	50 Aragon Club	07 - 09	<b>HF</b>
	50 Aragon GP	06 - 09	<b>HF</b>
	50 Aragon SP	07 - 09	<b>HF</b>
	50 Freaky	07 - 07	<b>HF</b>
	50 Hussar	03 - 06	<b>HF</b>
	50 Oliver	03 - 12	<b>HF</b>
	50 Oliver City	03 - 12	<b>HF</b>
	50 Oliver Sport	03 - 12	<b>HF</b>
	50 Popcorn	03 - 06	<b>HF</b>
	125 Aragon GP	07 - 12	<b>CT</b>
<b>GARELLI</b>			
	50 Flexi	12 - 12	<b>HF</b>
	50 Xo	12 - 12	<b>HF</b>
GSP	50	12 - 12	<b>HF</b>
<b>GENERIC</b>			
	50 Ideo	06 - 13	<b>HF</b>



<b>GENERIC</b>			
	50 ROC	08 - 11	<b>HF</b>
	50 Stroke	08 - 12	<b>HF</b>
	50 XOR	06 - 13	<b>HF</b>
	125 Soho	07 - 16	<b>CT</b>
	125 Stroke	08 - 15	<b>CT</b>
	125 XOR	07 - 11	<b>CT</b>
<b>ITALJET</b>			
SX1	50	08 - 10	<b>HF</b>
<b>KEEWAY</b>			
	50 Flash Electric	10 - 12	<b>HF</b>
	50 Focus	06 - 15	<b>HF</b>
	50 Matrix	06 - 15	<b>HF</b>
	50 Matrix Electric	10 - 15	<b>HF</b>
	50 Matrix Racing Sport	10 - 16	<b>HF</b>
F-NKD	50	10 - 11	<b>HF</b>
RY8	50	07 - 16	<b>HF</b>
	125 Focus	06 - 08	<b>CT</b>
	125 Matrix	06 - 08	<b>CT</b>
	125 Matrix Racing Sport	10 - 16	<b>CT</b>
	150 Focus	06 - 09	<b>CT</b>
	150 Matrix	06 - 08	<b>CT</b>
	150 Matrix Racing Sport	10 - 12	<b>CT</b>



<b>KYMCO</b>			
	50 Calypso	97 - 99	<b>HF</b>
	50 Heroism	97 - 99	<b>HF</b>
	125 Calypso	99 - 99	<b>CT</b>
	125 Heroism	95 - 97	<b>CT</b>
	150 Heroism	95 - 97	<b>CT</b>
<b>PEUGEOT</b>			
	e-Vivacity	11 - 15	<b>HF</b>
	50 Vivacity Sportline	11 - 11	<b>HF</b>
SV	80	96 - 98	<b>HF</b>
<b>TGB</b>			
GT	50 Veloce	09 - 12	<b>HF</b>

STREET  
AMERICAN  
SCOOTER

HF • HS • LS  
H.HF • H.CT • H.HS • H.LS  
HF • CT • MS

RACING  
OFF ROAD  
ATV

RST • DC • DCC • DS-1 • DS-2 • RQ  
SI • RSI • CS  
ATS • SI • RSI • PSI

Drawings 1:1

Available compounds

HF • CT

SBS 140

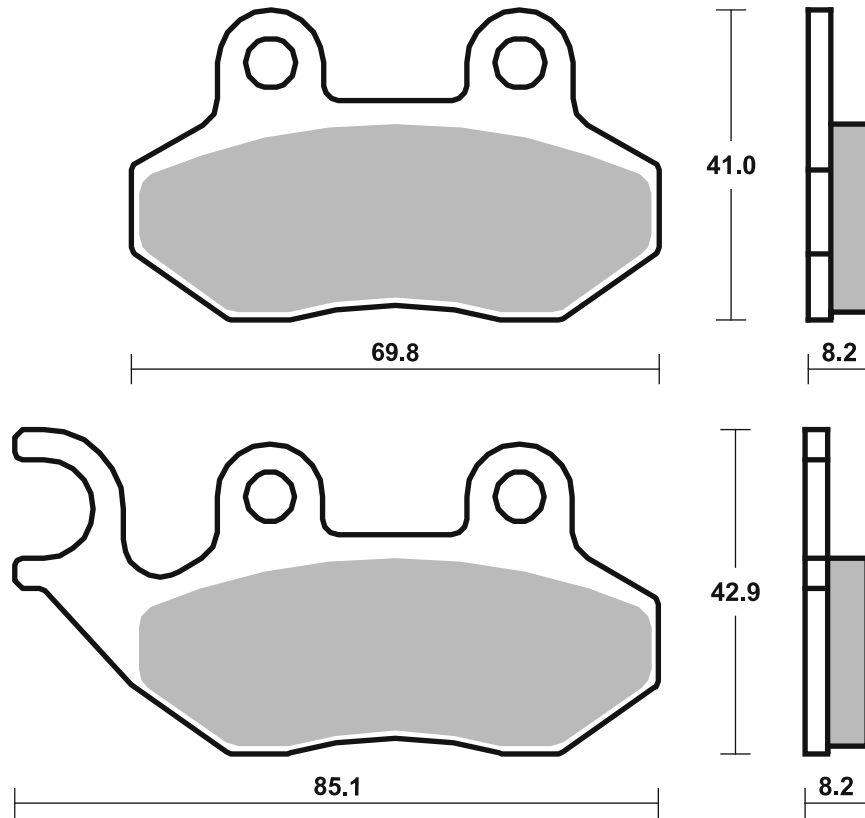

Available compounds

HF • CT

SBS 141

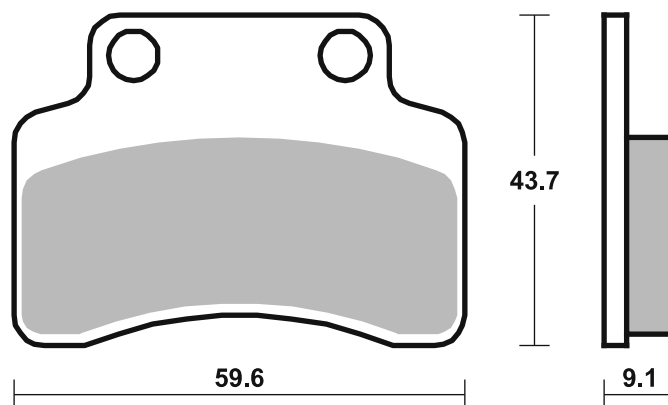

## SBS 142

## Recommended compound



DERBI		
50 Sonar	10 - 11	HF
PIAGGIO VESPA		
50 Zip RST	96 - 97	HF

## SBS 143

## Recommended compound



APRILIA		
50 Area 51	99 - 02	HF HF
50 Compay	09 - 13	HF
50 Habana/Custom	99 - 02	HF
50 Mojito Retro	99 - 03	HF
50 Mojito, Mojito Custom	99 - 12	HF
125 Leonardo	97 - 98	CT
150 Leonardo	97 - 98	CT
BENELLI		
50 Naked	02 - 02	HF
CPI		
125 GTR, GTS	02 - 03	CT
200 GTR, GTS	02 - 03	CT
GILERA		
50 DNA	01 - 07	HF
50 Runner	97 - 05	HF
50 Runner SP, Purejet	98 - 05	HF
50 Storm	94 - 98	HF
50 Typhoon	93 - 95	HF
80 Typhoon	95 - 99	HF
125 DNA	01 - 03	CT
175 Mad Mud	02 - 02	CT
180 DNA	01 - 03	CT
PIAGGIO VESPA		
50 Free		
(Disc Brake version)	97 - 99	HF
50 Storm	94 - 95	HF



PIAGGIO VESPA		
50 Typhoon	94 - 95	HF
50 Typhoon Catalyzed	02 - 08	HF HF
50 Zip Fast Rider	93 - 95	HF
LXV 50	08 - 08	HF
NRG 50 Extreme	01 - 01	HF
NRG 50 mc2	97 - 99	HF
NRG 50 mc3 DD	02 - 05	HF HF
NRG 50 mc3 DT	02 - 05	HF
NRG 50 Power DD	05 - 05	HF HF
NRG 50 Power DD	06 - 16	HF HF
NRG 50 Purejet	05 - 05	HF HF
NRG 50 Purejet	06 - 07	HF HF
NRG.1 50	94 - 95	HF
S 50 College 4T	11 - 14	HF
TPH 50	93 - 95	HF
100 Free 2T	02 - 02	HF
100 Free 4T	02 - 03	HF
125 Hexagon	94 - 95	CT
125 Typhoon Catalyzed	02 - 11	CT CT
LXV 125	08 - 11	CT
SKR 125	94 - 03	CT
150 Hexagon	94 - 97	CT
LX 150	08 - 11	CT
PUCH		
50 Storm (Austria)	78 - 83	HF
50 Typhoon (Austria)	95 - 95	HF

STREET  
AMERICAN  
SCOOTER

HF • HS • LS  
H.HF • H.CT • H.HS • H.LS  
HF • CT • MS

RACING  
OFF ROAD  
ATV

RST • DC • DCC • DS-1 • DS-2 • RQ  
SI • RSI • CS  
ATS • SI • RSI • PSI

Available compounds

HF • CT • MS

SBS 142

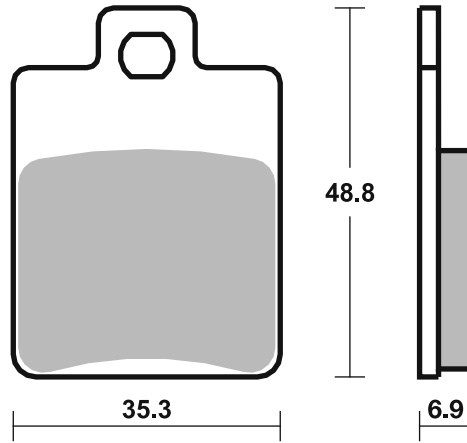

Available compounds

HF • CT

SBS 143

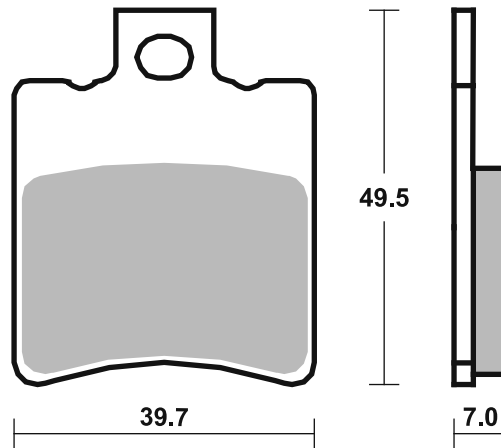

Brake Pad 1:1 Drawings,  
Compounds, Fitments

## Applications

### SBS 144

### Recommended compound



<b>DAELIM</b>			
SC	125 Besbi	08 - 13	<b>CT</b>
<b>HONDA</b>			
CB	50 Replica	99 - 00	<b>HF</b>
SRX	50 Shadow	98 - 99	<b>HF</b>
SRX	90 Shadow	99 - 99	<b>HF</b>
<b>KYMCO</b>			
	50 Cobra Cross	99 - 00	<b>HF</b>
	50 Cobra Racer	99 - 00	<b>HF</b>
	50 Super-9	00 - 01	<b>HF</b>
	50 ZX 12	06 - 06	<b>HF</b>
ZX	50 Super Fever	02 - 06	<b>HF</b>
	90 Manboy	96 - 01	<b>HF</b>
	125 Super-9	00 - 01	<b>CT</b>
	250 Super-9	00 - 05	<b>CT</b>

### SBS 145

### Recommended compound



<b>CPI</b>			
	50 GTS	02 - 03	<b>HF</b>
<b>MBK</b>			
	50 Nitro	97 - 10	<b>HF</b>
	50 Stunt	00 - 10	<b>HF</b>
<b>QUADRO</b>			
	350 3	16 - 16	<b>MS</b>
	350 4	16 - 16	<b>MS</b>
<b>YAMAHA</b>			
	50 Slider	00 - 05	<b>HF</b>
NS	50 Aerox	13 - 19	<b>HF</b>
YQ	50 Aerox	97 - 12	<b>HF</b>

### SBS 146

### Recommended compound



<b>DAELIM</b>			
	125 Otello	08 - 08	<b>CT</b>
	125 S2 FI	07 - 15	<b>CT</b>
QL	125 Steezer	17 - 19	<b>CT</b>
S	125 from VIN SDC007441	17 - 19	<b>CT</b>
S	125 to VIN SDC007440	17 - 19	<b>CT</b>
SL	125 U3 FI	07 - 09	<b>CT</b>
SV	125 S3	11 - 15	<b>CT</b>
S	300	17 - 19	<b>MS</b>
<b>KAWASAKI</b>			
SC	250 Epsilon	02 - 06	<b>MS</b>
<b>SUZUKI</b>			
	250 Sky Wave Type II	98 - 01	<b>MS</b>
AN	250 Burgman	98 - 06	<b>MS</b>



<b>SUZUKI</b>			
AN	400 Burgman	99 - 06	<b>MS</b>
<b>SYM</b>			
	125 GTS	07 - 11	<b>CT</b>
	125 Joymax Sport	16 - 16	<b>CT</b>
	250 GTS	07 - 11	<b>MS</b>
	250 Joymax Sport	16 - 17	<b>MS</b>
	300 Joyride Evo i	10 - 10	<b>MS</b>
GTS	300 Evo i	11 - 15	<b>MS</b>
	500 GT	07 - 04	<b>MS</b>



STREET  
AMERICAN  
SCOOTER

HF • HS • LS  
H.HF • H.CT • H.HS • H.LS  
HF • CT • MS

RACING  
OFF ROAD  
ATV

RST • DC • DCC • DS-1 • DS-2 • RQ  
SI • RSI • CS  
ATS • SI • RSI • PSI

Drawings 1:1

Available compounds

HF • CT

SBS 144

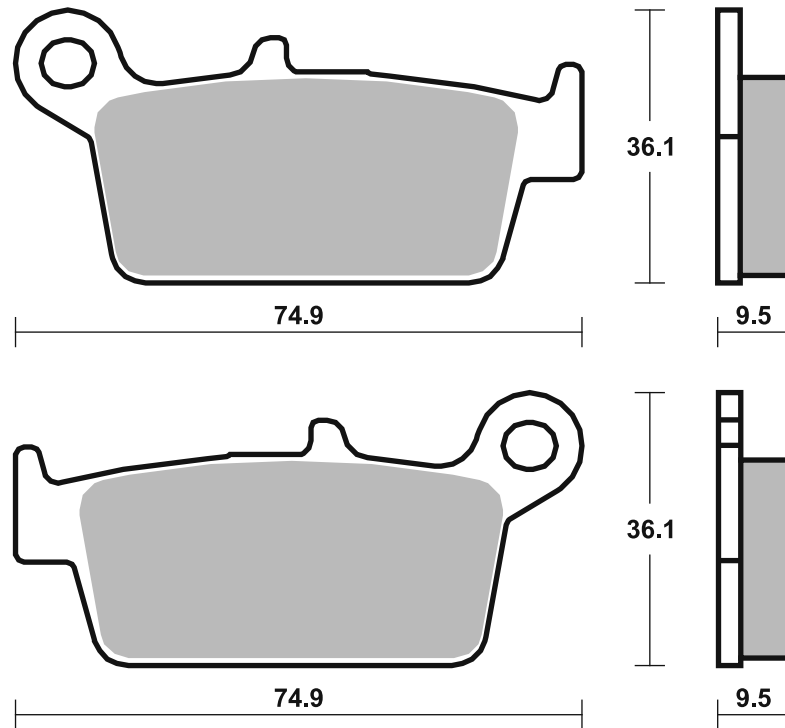

Available compounds

HF • CT • MS

SBS 145

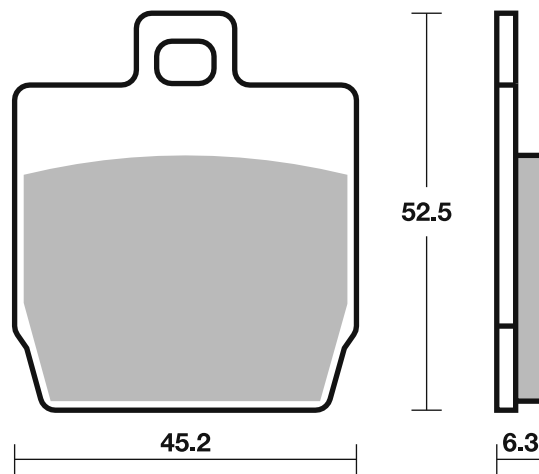

Available compounds

HF • CT • MS

SBS 146

1 set = 4 pcs.

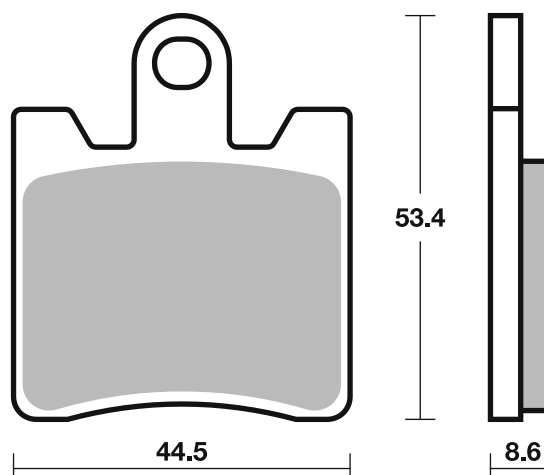

Applications

SBS 147 Recommended compound



HONDA

FES	125 Pantheon	98 - 06	CT
FES	150 Pantheon	99 - 06	CT

SBS 148 Recommended compound



<b>BETA</b>			
RR	50 Enduro	99 - 09	HF
RR	50 Pro Race	98 - 98	HF
RR	50 Standard	99 - 08	HF
RR	50 Supermotard	99 - 03	HF
<b>BULTACO</b>			
	50 Astro	01 - 06	HF
	50 Lobito	99 - 06	HF
<b>DERBI</b>			
	50 Senda R DRD	03 - 04	HF
GPR	50 R	98 - 03	HF
	125 Atmosphere	99 - 99	CT
	180 Predator	99 - 99	CT
<b>GASGAS</b>			
EC	50 Rookie	01 - 04	HF
SM	50 Rookie	01 - 02	HF
<b>GILERA</b>			
FX	125 Runner	97 - 99	CT
FX	150 Runner	97 - 01	CT
FXR	180 Runner	97 - 97	CT
FX	200 Runner	97 - 98	CT
<b>HRD</b>			
	50 Sonic 2 Supermotard	00 - 02	HF
	50 Sonic 2 Trail	00 - 02	HF
<b>HUSQVARNA</b>			
SM	50	02 - 02	HF



<b>HUSQVARNA</b>			
WR	50	02 - 02	HF
<b>ITALJET</b>			
SM	50	02 - 05	HF
<b>MOTORHISPANIA</b>			
RX	50 Racing	00 - 05	HF
<b>PEUGEOT</b>			
XR 6	50 Race Spec	02 - 07	HF
<b>RIEJU</b>			
	50 Racing Spec. Edition	01 - 01	HF
	50 Spike Racing	02 - 06	HF
MRX	50 Pro	05 - 09	HF
SMX	50	02 - 09	HF
<b>SHERCO</b>			
	50 Supermotard, Enduro	02 - 06	HF
<b>SIAMOTO</b>			
	125 BD, KD	02 - 04	CT
<b>TOMOS</b>			
SE	50	05 - 06	HF

Brake Pad 1:1 Drawings,  
Compounds, Fitments

STREET  
AMERICAN  
SCOOTER

HF • HS • LS  
H.HF • H.CT • H.HS • H.LS  
HF • CT • MS

RACING  
OFF ROAD  
ATV

RST • DC • DCC • DS-1 • DS-2 • RQ  
SI • RSI • CS  
ATS • SI • RSI • PSI

Drawings 1:1

Available compounds

HF • CT • MS

SBS 147

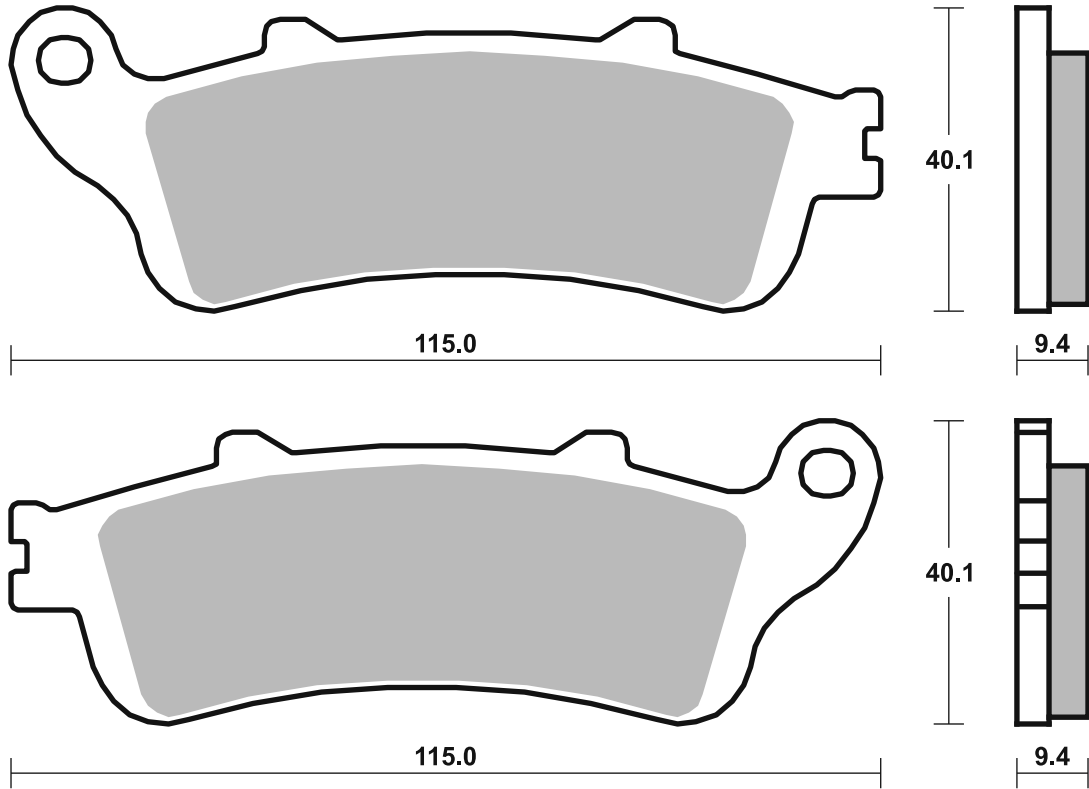

Available compounds

HF • CT

SBS 148

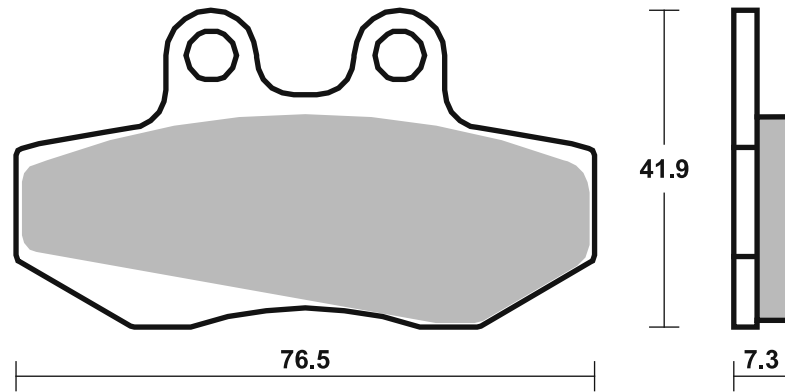

Applications

**SBS 149** Recommended compound



<b>APRILIA</b>			
SR	50 WWW, Netscaper	97 - 99	<b>HF</b>
	125 Leonardo	97 - 98	<b>CT</b>
	150 Leonardo	97 - 98	<b>CT</b>

**SBS 150** Recommended compound



<b>SYM</b>			
	125 Husky	99 - 05	<b>CT</b>
	150 Husky	99 - 02	<b>CT</b>

Brake Pad 1:1 Drawings, Compounds, Fitments

STREET  
AMERICAN  
SCOOTER

HF • HS • LS  
H.HF • H.CT • H.HS • H.LS  
HF • CT • MS

RACING  
OFF ROAD  
ATV

RST • DC • DCC • DS-1 • DS-2 • RQ  
SI • RSI • CS  
ATS • SI • RSI • PSI

Available compounds

HF • CT

SBS 149

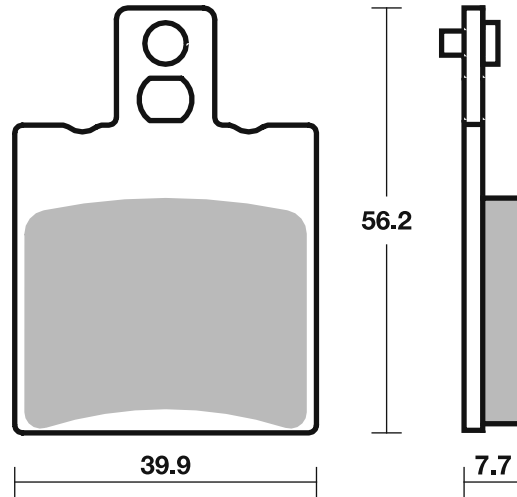

Available compounds

HF • CT

SBS 150

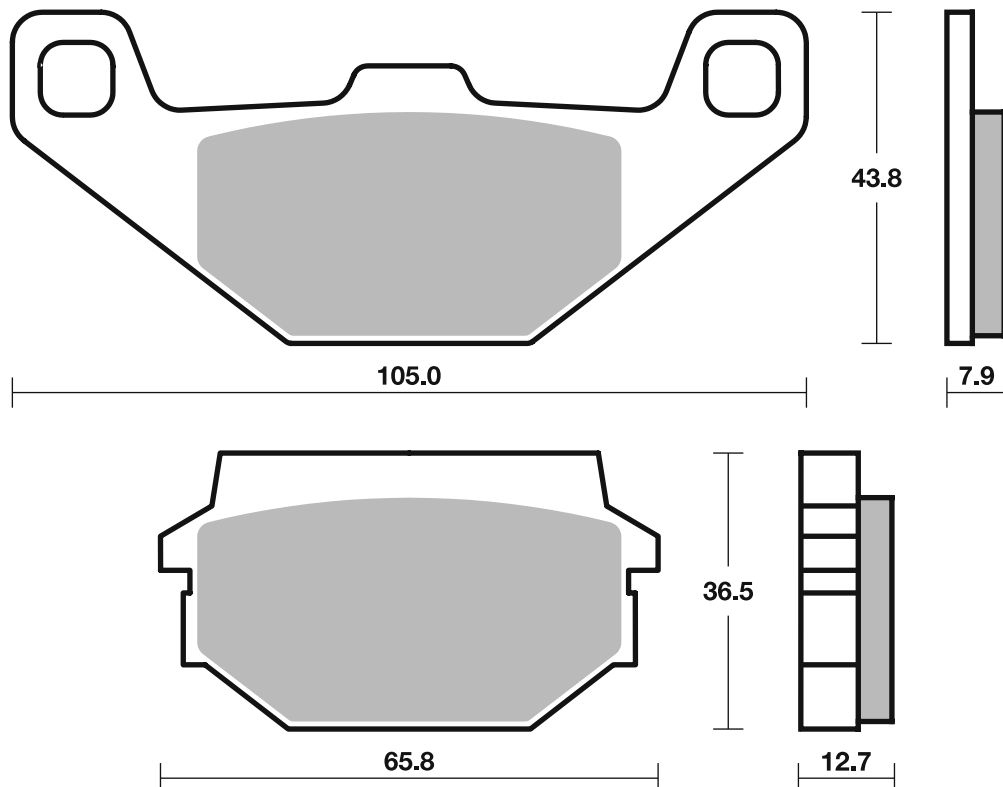

## Applications

### SBS 151

#### Recommended compound



<b>APRILIA</b>			
SRV	850	12 - 19	MS
<b>GILERA</b>			
	500 Nexus	04 - 12	MS
GP	800	08 - 15	MS
<b>ITALJET</b>			
	125 Dragster	20 - 23	CT
	200 Dragster	20 - 23	CT
<b>MBK</b>			
XQ	125 Thunder	01 - 04	CT
YP	125 Skyliner	99 - 12	CT
	150 Skyliner	01 - 03	CT
XQ	150 Thunder	02 - 03	CT
	180 Skyliner	04 - 07	CT
	300 Kilibre	03 - 08	MS MS
<b>PIAGGIO VESPA</b>			
	500 X9 Evolution	04 - 07	MS
	500 X9 Evolution ABS	04 - 07	MS
<b>SUZUKI</b>			
UH	125 Burgman	02 - 06	CT
UH	150 Burgman	04 - 06	CT
<b>YAMAHA</b>			
XQ	125 Maxter	01 - 05	CT
YP	125 Majesty	01 - 11	CT
YP	125 R Majesty	99 - 00	CT
XQ	150 Maxter	01 - 02	CT



<b>YAMAHA</b>			
YP	150 Majesty	01 - 02	CT
YP	180 R Majesty	03 - 06	CT
VP	300 Versity	03 - 04	MS MS
VP	300 Versity	05 - 06	MS

### SBS 152

#### Recommended compound



<b>APRILIA</b>			
	50 Scarabeo Ditech	02 - 06	HF
SR	50 Ditech	01 - 06	HF
SR	50 Racing	00 - 04	HF
SR	50 Street	05 - 12	HF
	125 Atlantic	03 - 14	CT
	125 Scarabeo,		
	Scarabeo GT	99 - 10	CT
	125 Sportcity		
	(Grimeca cal.)	04 - 12	CT
	125 Sportcity		
	(Hengtong cal.)	04 - 12	CT
	150 Scarabeo	99 - 04	CT
	150 Scarabeo,		
	Scarabeo GT	04 - 05	CT
	200 Atlantic	03 - 06	CT
	200 Scarabeo	07 - 09	CT
	200 Scarabeo Class	10 - 12	CT
	200 Scarabeo ie	12 - 12	CT
	200 Scarabeo,		
	Scarabeo GT	02 - 03	CT
	200 Sportcity	04 - 08	CT
	250 Atlantic	07 - 12	MS
	250 Leonardo	99 - 05	MS
	250 Leonardo		
	(Grimeca cal.)	99 - 05	MS
	250 Scarabeo,		
	Scarabeo ie	06 - 11	MS
	250 Sportcity	06 - 08	MS
	300 Scarabeo Special	10 - 11	MS
	400 Scarabeo ie	07 - 08	MS
	500 Atlantic	02 - 05	MS



<b>APRILIA</b>			
	500 Atlantic Sprint	06 - 10	MS
	500 Scarabeo	03 - 06	MS
	500 Scarabeo Classic	10 - 11	MS
	500 Scarabeo ie	07 - 11	MS
<b>BETA</b>			
	50 Eikon	04 - 07	HF
	125 Eikon	04 - 06	CT
	150 Eikon	04 - 04	CT
<b>DERBI</b>			
	125 Rambla	08 - 14	CT
	300 Rambla	08 - 12	MS
<b>KEEWAY</b>			
	125 Cityblade	17 - 19	HF
<b>MALAGUTI</b>			
	125 Phantom Max	04 - 08	CT
	125 Sport City Cube	08 - 08	CT
F-18	125 , Warrior	00 - 02	CT
R	125 Madison	99 - 09	CT
	150 Madison	99 - 03	CT
	180 Madison	02 - 02	CT
	200 Phantom Max	04 - 05	CT
	200 Sport City Cube	08 - 08	CT
S	200 Madison	03 - 06	CT
	250 Madison	99 - 04	MS
	250 Password Special	06 - 08	CT
	250 Phantom Max	05 - 08	CT
	250 Sport City Cube	08 - 08	MS



<b>MALAGUTI</b>			
RS	250 Madison	05 - 11	CT
	300 Sport City Cube	08 - 08	MS
K	400 Madison	02 - 11	MS



STREET  
AMERICAN  
SCOOTER

HF • HS • LS  
H.HF • H.CT • H.HS • H.LS  
HF • CT • MS

RACING  
OFF ROAD  
ATV

RST • DC • DCC • DS-1 • DS-2 • RQ  
SI • RSI • CS  
ATS • SI • RSI • PSI

Available compounds

HF • CT • MS

SBS 151

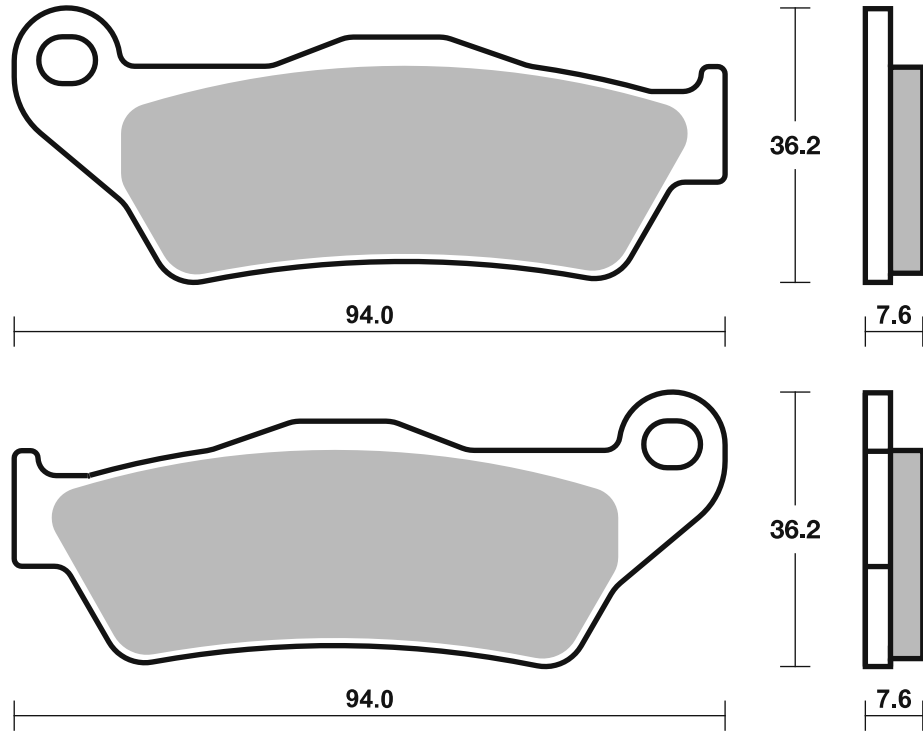

Available compounds

HF • CT • MS

SBS 152

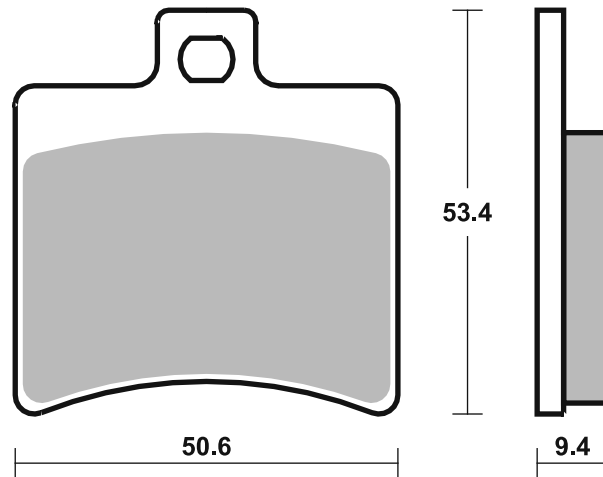

Applications

**SBS 153** Recommended compound



<b>APRILIA</b>			
	50 Scarabeo 4T	04 - 09	<b>HF</b>
	100 Scarabeo	00 - 06	<b>HF</b>
	100 Scarabeo 4T	03 - 11	<b>HF</b>
	100 Scarabeo Net	10 - 14	<b>HF</b>
	125 Habana/Custom	00 - 02	<b>CT</b>
	125 Leonardo	99 - 06	<b>CT CT</b>
	125 Leonardo (Grimeca cal.)	99 - 06	<b>CT</b>
	125 Mojito, Mojito Custom	02 - 12	<b>CT</b>
SR	125	99 - 03	<b>CT</b>
	150 Leonardo	99 - 05	<b>CT CT</b>
	150 Leonardo (Grimeca cal.)	99 - 05	<b>CT</b>
SR	150	00 - 03	<b>CT</b>
	250 Leonardo	99 - 05	<b>MS</b>
	300 Leonardo (Grimeca cal.)	05 - 06	<b>MS</b>

**SBS 154** Recommended compound



<b>KYMCO</b>			
	50 Agility (4T) R16	06 - 15	<b>HF</b>
	50 People	99 - 06	<b>HF</b>
	50 Super-8	08 - 16	<b>HF</b>
	50 Super-9 L/C	02 - 07	<b>HF</b>
	125 Agility 16+	14 - 16	<b>CT</b>
	125 People	01 - 09	<b>CT</b>
	125 People One i	14 - 16	<b>CT</b>
	125 Super-8	08 - 15	<b>CT</b>
	125 Super-9	00 - 01	<b>CT</b>
S	125 People	05 - 08	<b>CT</b>
	150 People	01 - 06	<b>CT</b>
	200 Agility 16+	14 - 17	<b>CT</b>
	200 Agility R16	11 - 15	<b>CT</b>
S	200 People	05 - 07	<b>CT</b>
	250 Super-9	00 - 05	<b>CT</b>
<b>LAVERDA</b>			
	125 Phoenix	01 - 04	<b>CT</b>
	150 Phoenix	01 - 04	<b>CT</b>
	200 Phoenix	01 - 04	<b>CT</b>
<b>SYM</b>			
	125 Joyride	01 - 06	<b>CT</b>
HD	125	04 - 10	<b>CT</b>
	150 Joyride	01 - 06	<b>CT</b>
	200 Joyride	01 - 08	<b>CT</b>
HD	200	04 - 06	<b>CT</b>
	500 GT	07 - 04	<b>MS</b>

Brake Pad 1:1 Drawings,  
Compounds, Fitments

STREET  
AMERICAN  
SCOOTER

HF • HS • LS  
H.HF • H.CT • H.HS • H.LS  
HF • CT • MS

RACING  
OFF ROAD  
ATV

RST • DC • DCC • DS-1 • DS-2 • RQ  
SI • RSI • CS  
ATS • SI • RSI • PSI

Available compounds

HF • CT • MS

SBS 153

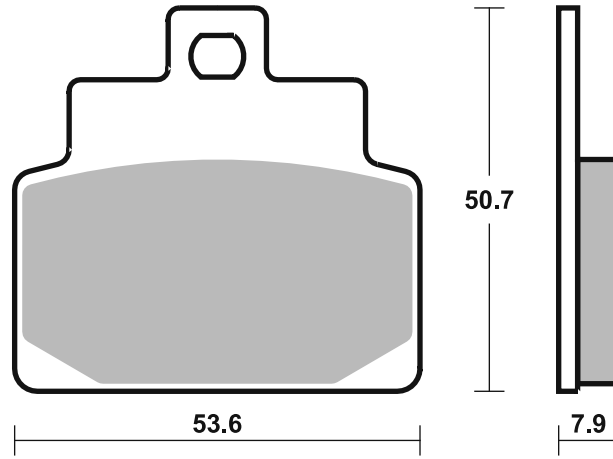

Available compounds

HF • CT • MS

SBS 154

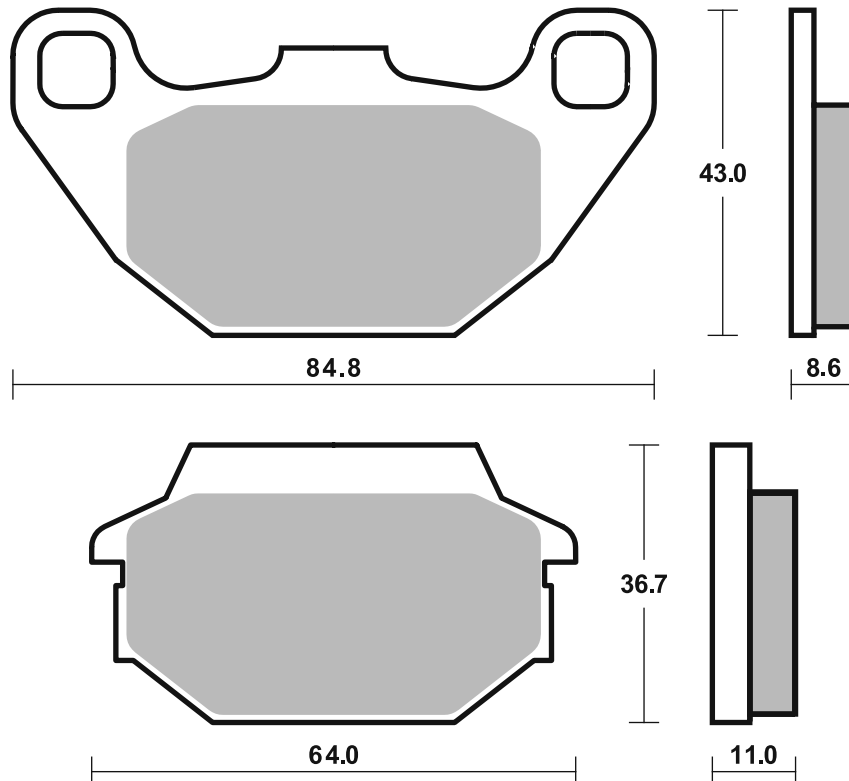

**Applications**

**SBS 155 Recommended compound**



<b>MBK</b>			
250 Skyliner	00 - 02		<b>MS</b>
<b>YAMAHA</b>			
YP 125 XMAX ABS	11 - 16		<b>CT</b>
YP 125 XMAX Business ABS	11 - 13		<b>CT</b>
VP 250 X-City	07 - 09		<b>MS</b>
YP 250 D Majesty DX	98 - 00		<b>MS</b>
YP 250 Majesty DX/ABS	99 - 14		<b>MS</b>
YP 250 XMAX	05 - 13		<b>MS</b>

**SBS 156 Recommended compound**



<b>HONDA</b>			
FES 250 Foresight	98 - 07		<b>MS</b>
NSS 250	00 - 04		<b>MS</b>
NSS 250 Forza	00 - 04		<b>MS</b>
NSS 250 Jazz	01 - 04		<b>MS</b>
FJS 400 Silverwing	06 - 08		<b>MS</b>
FJS 600 Silverwing	01 - 08		<b>MS</b>
<b>PEUGEOT</b>			
125 Looxor	03 - 07		<b>CT</b>

Brake Pad 1:1 Drawings,  
Compounds, Fitments

STREET  
AMERICAN  
SCOOTER

HF • HS • LS  
H.HF • H.CT • H.HS • H.LS  
HF • CT • MS

RACING  
OFF ROAD  
ATV

RST • DC • DCC • DS-1 • DS-2 • RQ  
SI • RSI • CS  
ATS • SI • RSI • PSI

Drawings 1:1

Available compounds

HF • CT • MS

SBS 155

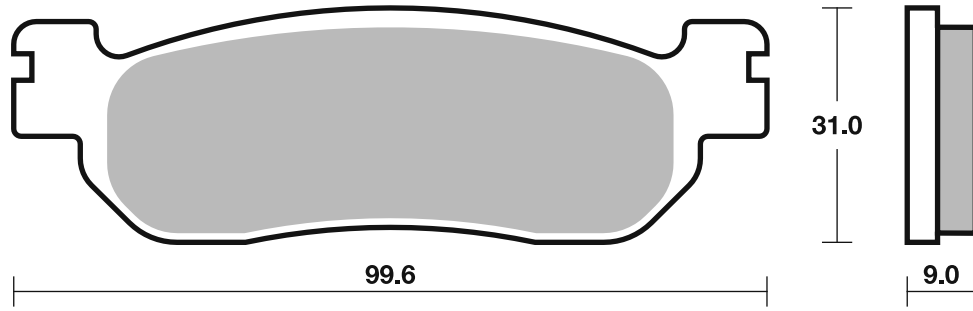

Available compounds

HF • CT • MS

SBS 156

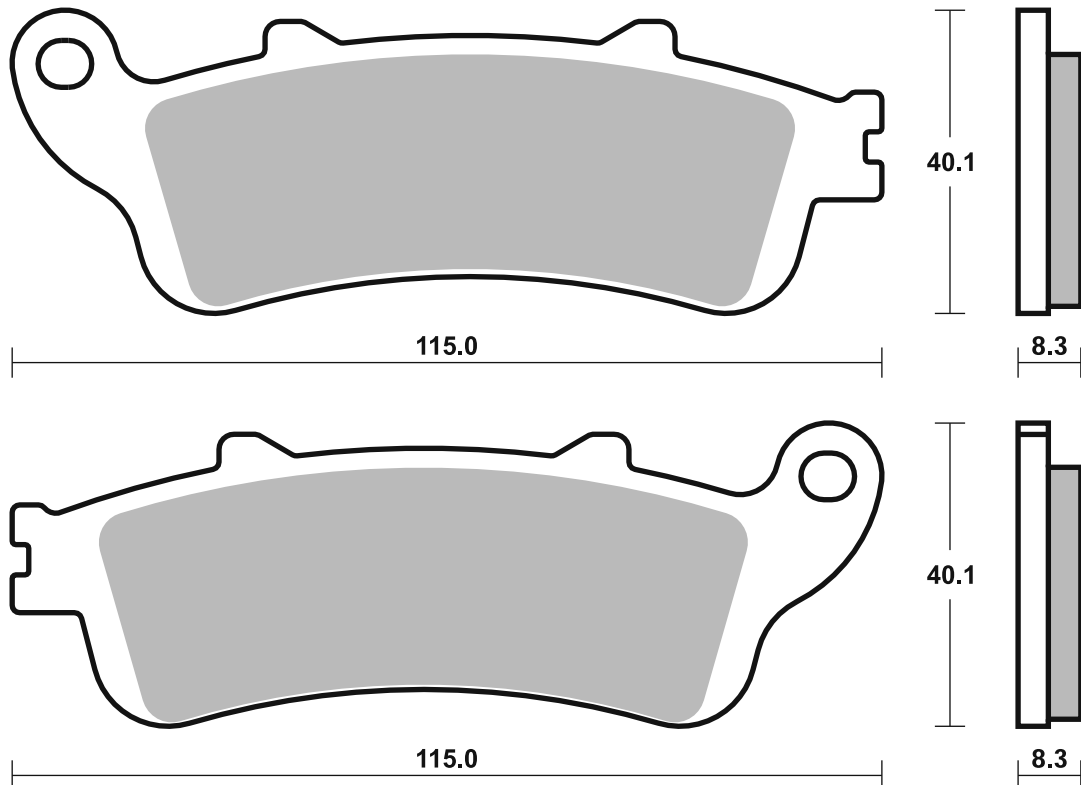





STREET  
AMERICAN  
SCOOTER

HF • HS • LS  
H.HF • H.CT • H.HS • H.LS  
HF • CT • MS

RACING  
OFF ROAD  
ATV

RST • DC • DCC • DS-1 • DS-2 • RQ  
SI • RSI • CS  
ATS • SI • RSI • PSI

Available compounds

HF • CT • MS

SBS 157

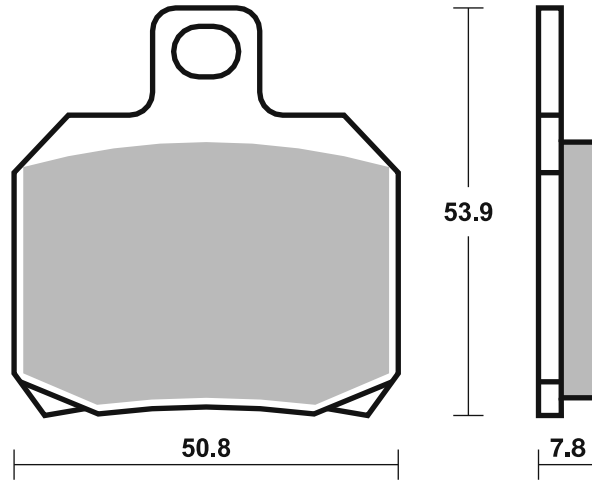

Available compounds

HF • CT • MS

SBS 158

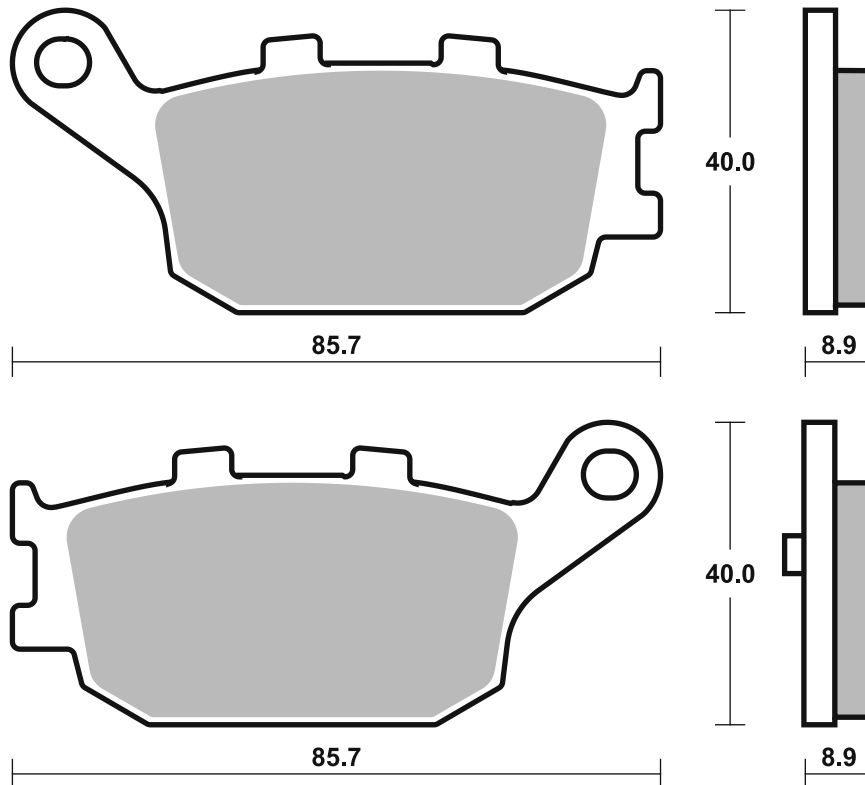

# Applications

## SBS 159

### Recommended compound



<b>APRILIA</b>		
125 Atlantic	03 - 14	CT
125 Scarabeo,		
Scarabeo GT	04 - 10	CT
150 Scarabeo,		
Scarabeo GT	04 - 05	CT
200 Atlantic	03 - 06	CT
200 Scarabeo	07 - 09	CT
200 Scarabeo Class	10 - 12	CT
200 Scarabeo ie	12 - 12	CT
250 Atlantic	07 - 12	MS
250 Scarabeo,		
Scarabeo ie	06 - 11	MS
300 Scarabeo Special	10 - 11	MS
500 Atlantic Sprint	06 - 10	MS

#### KYMCO

125 Dink X	22 - 22	CT
125 New Downtown	16 - 17	CT
125 People GTi	12 - 15	CT
125 X-Town	16 - 17	MS
125 X-Town CT	20 - 20	CT
DT 125 X360	22 - 23	CT
200 People GTi	12 - 15	CT
300 K-XCTi	12 - 15	MS
300 People GTi	12 - 15	MS
300 People S	20 - 20	MS
300 X-Town	16 - 20	MS
300 X-Town CT	20 - 20	MS
350 New Downtown	16 - 17	MS
DT 350 X360	23 - 23	MS



<b>MALAGUTI</b>		
250 Madison	99 - 04	MS
K 400 Madison	02 - 11	MS

#### PIAGGIO VESPA

350 Beverly Sport		
Touring ie	12 - 19	MS

## SBS 160

### Recommended compound



#### HONDA

CN 250 Helix	86 - 87	CT
--------------	---------	----

STREET  
AMERICAN  
SCOOTER

HF • HS • LS  
H.HF • H.CT • H.HS • H.LS  
HF • CT • MS

RACING  
OFF ROAD  
ATV

RST • DC • DCC • DS-1 • DS-2 • RQ  
SI • RSI • CS  
ATS • SI • RSI • PSI

Drawings 1:1

Available compounds

HF • CT • MS

SBS 159

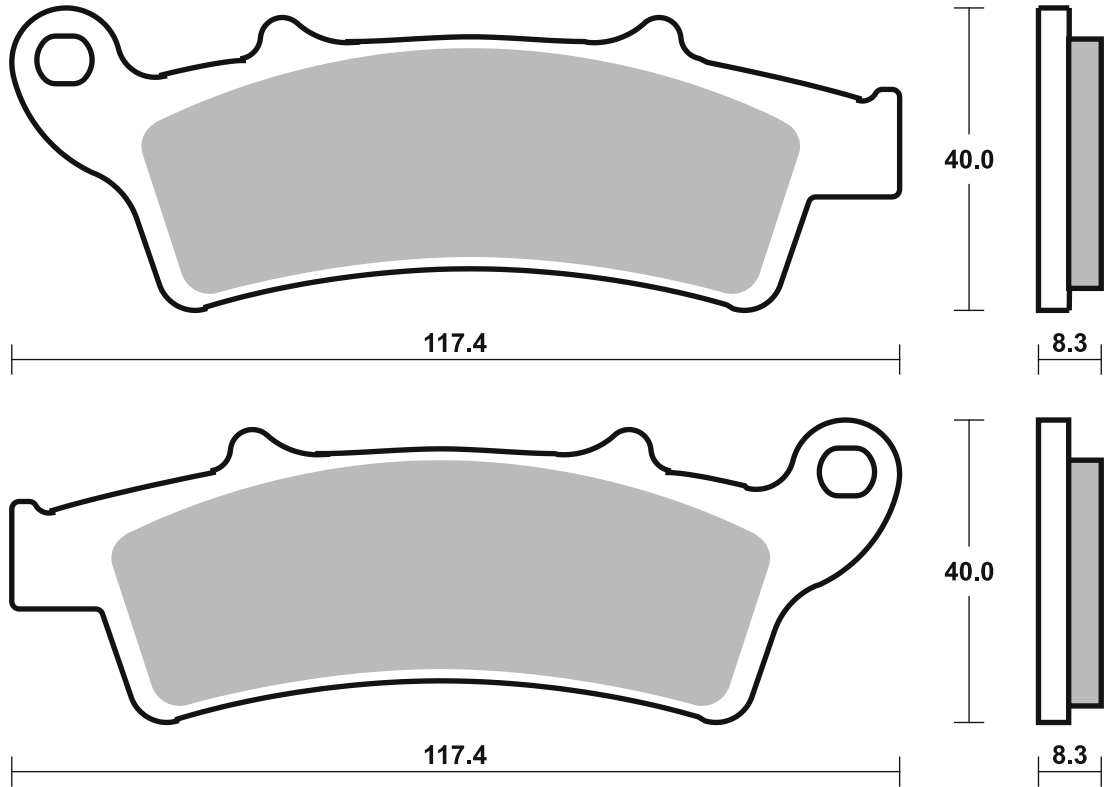

Available compounds

HF • CT

SBS 160

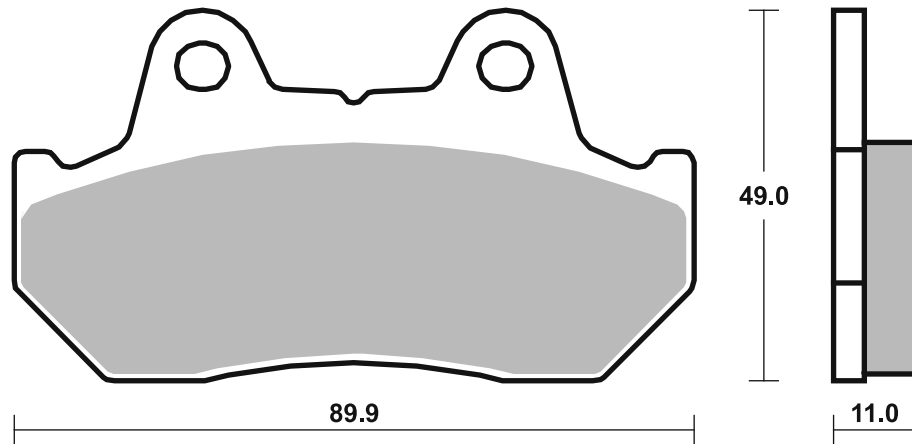

## Applications

### SBS 161

### Recommended compound



<b>HONDA</b>			
FES	125 Pantheon	03 - 06	<b>CT</b>
FES	150 Pantheon	03 - 06	<b>CT</b>
FES	250 Foresight	00 - 07	<b>MS</b>
<b>ZONTES</b>			
	310 M	21 - 22	<b>MS</b>

### SBS 163

### Recommended compound



<b>AEON</b>			
	125 Elite	13 - 14	<b>CT</b>
	125 Urban	11 - 13	<b>CT</b>
	250 Elite	11 - 14	<b>CT</b>
	350 Urban	11 - 13	<b>CT</b>
<b>BENELLI</b>			
	350 Zenzero	12 - 15	<b>CT</b>
<b>DAELIM</b>			
	50 a Four	06 - 12	<b>HF</b>
	125 Delfino	08 - 11	<b>CT</b>
<b>GENERIC</b>			
	125 Zion	08 - 15	<b>CT</b>
<b>KYMCO</b>			
	50 Agility	05 - 08	<b>HF</b>
	50 Agility (4T) R10	06 - 14	<b>HF</b>
	50 Agility (4T) R12	06 - 15	<b>HF</b>
	50 Filly LX	02 - 06	<b>HF</b>
	50 New Sento	11 - 15	<b>HF</b>
	50 Sento	08 - 10	<b>HF</b>
	50 Vitality	04 - 09	<b>HF</b>
	50 Yup SP/AL	02 - 09	<b>HF</b>
RS	50 Agility Naked	10 - 15	<b>HF</b>
	125 Agility	06 - 11	<b>CT</b>
	125 Agility City	11 - 17	<b>CT</b>
	125 Like	11 - 16	<b>CT</b>
	125 Stryker on/off	99 - 06	<b>CT</b>
	125 Vivio	01 - 03	<b>CT</b>
	150 Stryker Off	01 - 06	<b>CT</b>



<b>KYMCO</b>			
	150 Vivio	01 - 02	<b>CT</b>
	300 People Si	08 - 10	<b>CT</b>
<b>MALAGUTI</b>			
	125 Blog	10 - 10	<b>CT</b>
	125 Centro ie	08 - 11	<b>CT</b>
	160 Blog	10 - 11	<b>CT</b>
	160 Centro ie	08 - 11	<b>CT</b>
<b>PGO</b>			
	125 I-Charge Fuel		
	Injection	03 - 08	<b>CT</b>
<b>TGB</b>			
	50 203	05 - 08	<b>HF</b>
	50 Akros tec 5	99 - 04	<b>HF</b>
	50 Apollo	99 - 03	<b>HF</b>
	50 Fire, Sky	03 - 05	<b>HF</b>
	90 Apollo	99 - 02	<b>HF</b>
	250 Dynasty	06 - 06	<b>CT</b>

Brake Pad 1:1 Drawings,  
 Compounds, Fitments

STREET  
AMERICAN  
SCOOTER

HF • HS • LS  
H.HF • H.CT • H.HS • H.LS  
HF • CT • MS

RACING  
OFF ROAD  
ATV

RST • DC • DCC • DS-1 • DS-2 • RQ  
SI • RSI • CS  
ATS • SI • RSI • PSI

Available compounds

HF • CT • MS

SBS 161

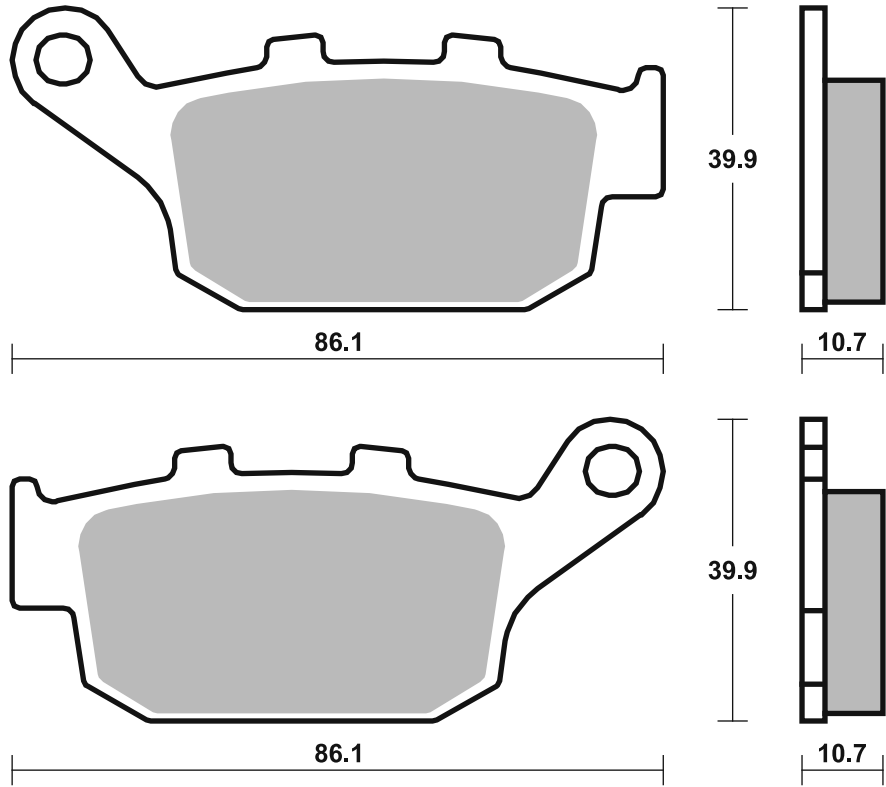

Available compounds

HF • CT

SBS 163

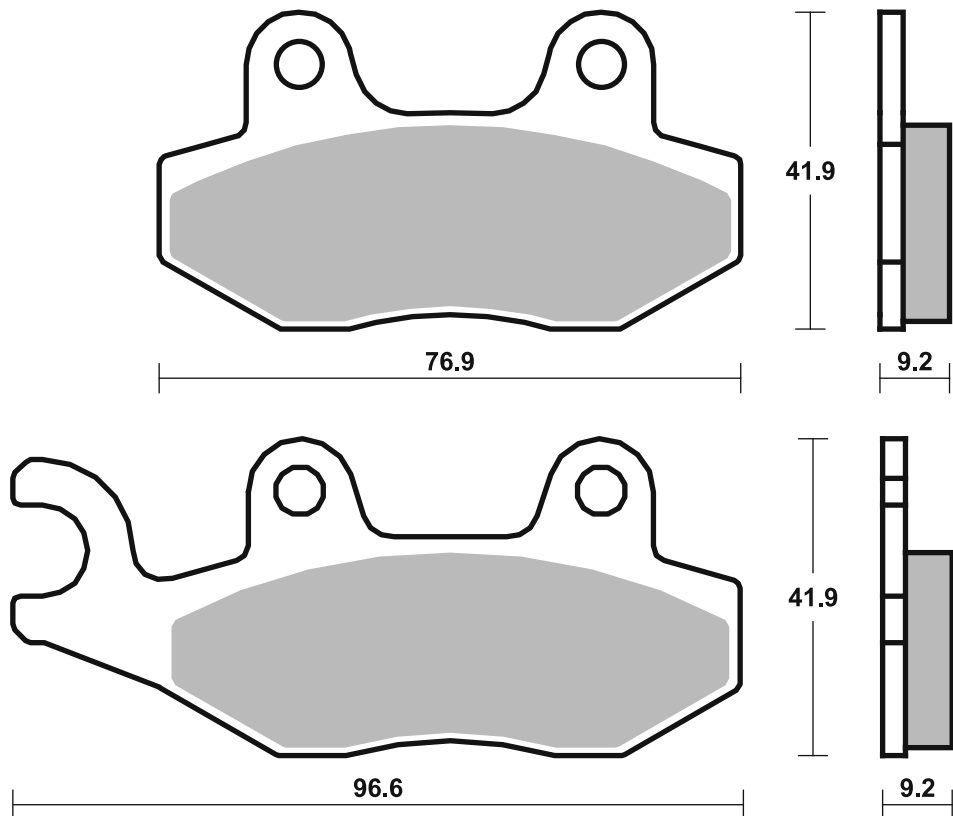





STREET  
AMERICAN  
SCOOTER

HF • HS • LS  
H.HF • H.CT • H.HS • H.LS  
HF • CT • MS

RACING  
OFF ROAD  
ATV

RST • DC • DCC • DS-1 • DS-2 • RQ  
SI • RSI • CS  
ATS • SI • RSI • PSI

Available compounds

HF • CT

SBS 164

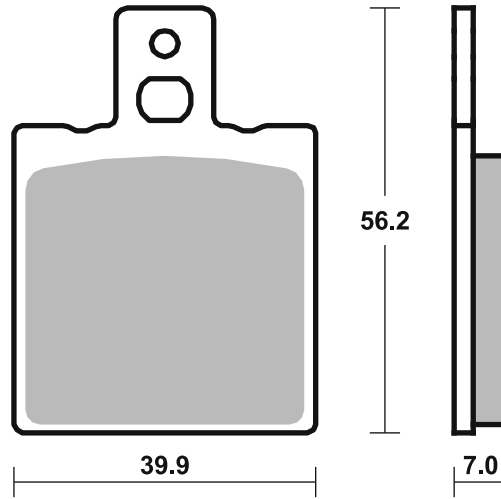

Available compounds

HF • CT

SBS 165

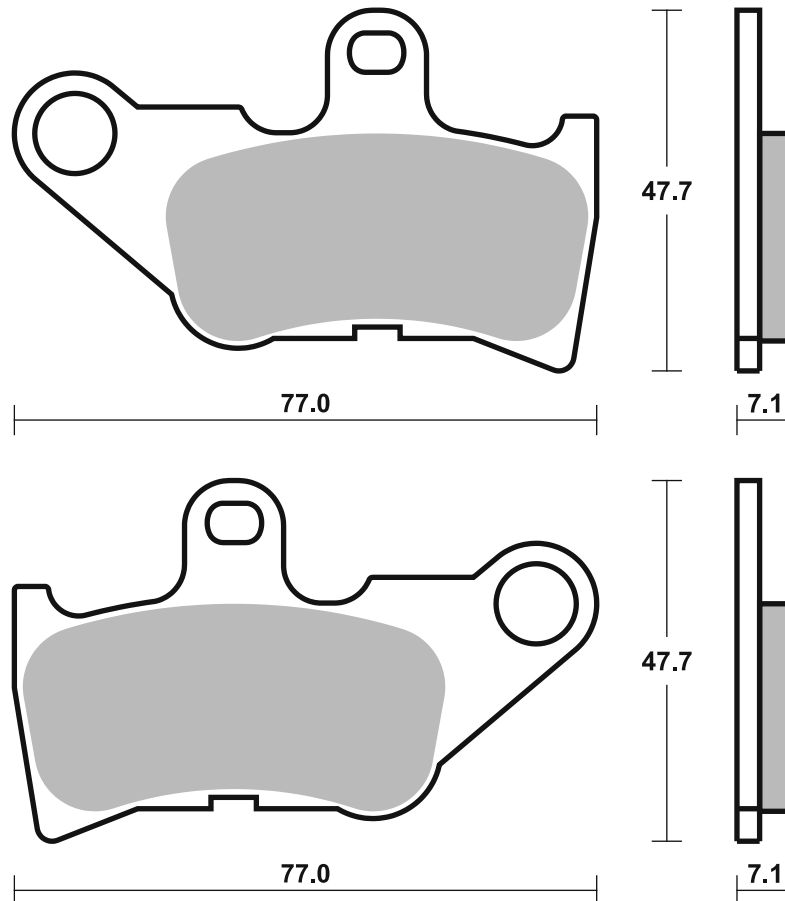

## Applications

### SBS 166

### Recommended compound



<b>BENELLI</b>			
	125 Adiva	00 - 05	<b>CT</b>
	150 Adiva	00 - 05	<b>CT</b>
<b>GILERA</b>			
ST	125 Runner	08 - 11	<b>CT</b>
VX	125 Runner 4T (Grimeca cal.)	01 - 12	<b>CT</b>
VX	125 Runner 4T (Hengtong cal.)	01 - 12	<b>CT</b>
VXR	180 Runner 4T (Grimeca cal.)	01 - 08	<b>CT</b>
VXR	180 Runner 4T (Hengtong cal.)	01 - 08	<b>CT</b>
ST	200 Runner	08 - 11	<b>CT</b>
VXR	200 Runner 4T (Grimeca cal.)	01 - 09	<b>CT</b>
VXR	200 Runner 4T (Hengtong cal.)	01 - 09	<b>CT</b>
<b>PIAGGIO VESPA</b>			
	125 946	14 - 16	<b>CT</b>
GT	125 L	04 - 09	<b>CT</b>
GTS	125	07 - 10	<b>CT</b>
GTS	125 Super	10 - 13	<b>CT</b>
GTS	125 Super i.e.	15 - 16	<b>CT</b>
GTS	125 Supersport	13 - 13	<b>CT</b>
GTS	125 Touring	18 - 19	<b>CT</b>
GTV	125	08 - 09	<b>CT</b>
GTX	125 SuperHexagon (Grimeca cal.) (11" wheels)	00 - 00	<b>CT</b>



<b>PIAGGIO VESPA</b>			
GTX	125 SuperHexagon (Hengtong cal.) (11" wheels)	00 - 00	<b>CT</b>
GTX	125 SuperHexagon (Hengtong cal.) (12" wheels)	01 - 03	<b>CT</b>
GTX	180 SuperHexagon (Grimeca cal.) (11" wheels)	00 - 00	<b>CT</b>
GTX	180 SuperHexagon (Hengtong cal.) (11" wheels)	00 - 00	<b>CT</b>
GTX	180 SuperHexagon (Hengtong cal.) (12" wheels)	01 - 03	<b>CT</b>
GT	200 L	04 - 09	<b>CT</b>
	250 GT 60	06 - 07	<b>MS</b>
GTS	250	06 - 07	<b>MS</b>
GTV	250	08 - 10	<b>MS</b>
GTX	250 Super Hexagon	01 - 02	<b>MS</b>
	300 Sei Giorni	18 - 19	<b>MS</b>
GTS	300 i.e.	12 - 15	<b>MS</b>
GTS	300 Super	09 - 12	<b>MS</b>
GTS	300 Super Notte	19 - 20	<b>MS</b>
GTS	300 Super Sport i.e.	11 - 15	<b>MS</b>
GTS	300 Touring ABS	17 - 17	<b>MS</b>
GTS	300 Touring i.e.	11 - 12	<b>MS</b>
GTS	300 Yacht Club	18 - 18	<b>MS</b>
GTV	300 i.e.	11 - 15	<b>MS</b>

### SBS 167

### Recommended compound



<b>DERBI</b>			
	50 Senda DRD Pro SM	05 - 11	<b>HF</b>
	125 Boulevard	03 - 07	<b>CT</b>
	125 Senda Baja	06 - 12	<b>CT</b>
	150 Boulevard	03 - 09	<b>CT</b>
<b>ITALJET</b>			
	50 Jet-Set	02 - 03	<b>HF</b>
	100 Millennium 2T	01 - 01	<b>HF</b>
	125 Jet-Set	02 - 03	<b>CT</b>
	125 Millennium	00 - 03	<b>CT</b>
	150 Jet-Set	02 - 03	<b>CT</b>
	150 Millennium	00 - 03	<b>CT</b>
<b>PEUGEOT</b>			
	50 Elystar	03 - 05	<b>HF</b>
	125 Elyseo	00 - 07	<b>CT</b>
	125 Elystar	03 - 07	<b>CT</b>
	125 Geopolis	06 - 09	<b>CT</b>
	125 Jet-Force Compressor	03 - 04	<b>CT</b>
	125 Looxor	03 - 07	<b>CT</b>
	125 Satelis	04 - 16	<b>CT</b>
	125 Satelis ABS	04 - 08	<b>CT</b>
RS	125 Geopolis	10 - 13	<b>CT</b>
	150 Elyseo	00 - 04	<b>CT</b>
	150 Elystar	03 - 04	<b>CT</b>
	250 Geopolis (AJP cal.)	06 - 11	<b>CT</b>
	400 Geopolis (AJP cal.)	07 - 12	<b>CT</b>
	600 Satelis ABS	04 - 12	<b>CT</b>



<b>RIEJU</b>			
RS2	50 Matrix	03 - 09	<b>HF</b>
<b>SHERCO</b>			
SE	50 Enduro	07 - 07	<b>HF</b>
SM	50 Supermotard	07 - 13	<b>HF</b>
<b>YAMAHA</b>			
DT	50 R	04 - 08	<b>HF</b>
DT	50 X Supermotard	04 - 08	<b>HF</b>

STREET  
AMERICAN  
SCOOTER

HF • HS • LS  
H.HF • H.CT • H.HS • H.LS  
HF • CT • MS

RACING  
OFF ROAD  
ATV

RST • DC • DCC • DS-1 • DS-2 • RQ  
SI • RSI • CS  
ATS • SI • RSI • PSI

Drawings 1:1

Available compounds

HF • CT • MS

SBS 166

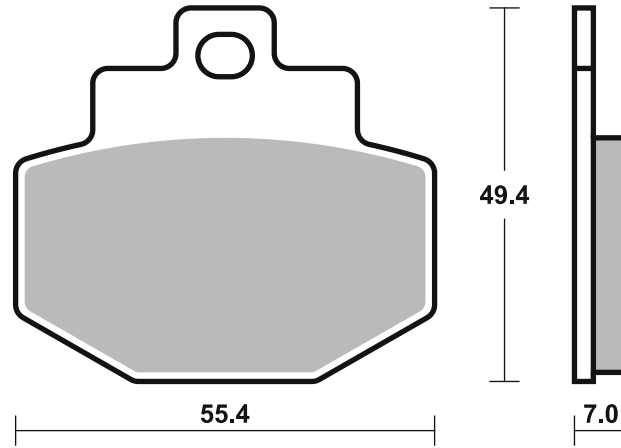

Available compounds

HF • CT

SBS 167

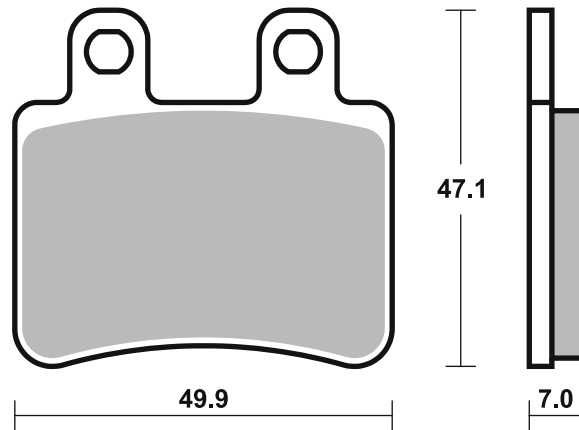

## Applications

### SBS 168

### Recommended compound



<b>APRILIA</b>			
50 Tuono	04 - 07	<b>HF</b>	
<b>BETA</b>			
RR 50 Enduro	10 - 18	<b>HF</b>	
RR 50 Supermotard	08 - 13	<b>HF</b>	
<b>DERBI</b>			
50 Black Devil	04 - 04	<b>HF</b>	
50 DRD Racing R	05 - 10	<b>HF</b>	
50 DRD Racing R Ltd.	05 - 05	<b>HF</b>	
50 DRD Racing SM	05 - 05	<b>HF</b>	
50 DRD Racing SM Ltd.	05 - 05	<b>HF</b>	
50 Senda SM DRD			
Black Edition	03 - 04	<b>HF</b>	
125 Senda Baja	06 - 12	<b>HF</b>	
<b>FANTIC</b>			
50 Regolarna Casa	08 - 09	<b>HF</b>	
50 Supersei Motard	08 - 09	<b>HF</b>	
<b>GASGAS</b>			
EC 50 Rookie	05 - 05	<b>HF</b>	
<b>GENERIC</b>			
50 Toxic	07 - 16	<b>HF</b>	
50 Trigger SM	06 - 14	<b>HF</b>	
50 Trigger SM			
Competition	08 - 14	<b>HF</b>	
50 Trigger X	06 - 14	<b>HF</b>	
50 Trigger X			
Competition	08 - 12	<b>HF</b>	



<b>MALAGUTI</b>			
50 Fifty	04 - 04	<b>HF</b>	
NKD 50	04 - 09	<b>HF</b>	
125 Phantom Max	04 - 08	<b>CT</b>	
200 Phantom Max	04 - 05	<b>CT</b>	
250 Password	06 - 08	<b>CT</b>	
250 Phantom Max	05 - 08	<b>CT</b>	
RS 250 Madison	05 - 11	<b>CT</b>	
<b>MBK</b>			
50 X-Power	04 - 13	<b>HF</b>	
<b>MOTORHISPANIA</b>			
MH 50 Urban Bike	06 - 10	<b>HF</b>	
<b>PEUGEOT</b>			
XP S-6 50 Supermotard	04 - 05	<b>HF</b>	
125 Elyseo	00 - 07	<b>CT</b>	
125 Elystar	03 - 07	<b>CT</b>	
125 Jet-Force			
Compressor	03 - 04	<b>CT</b>	
125 Satelis	06 - 16	<b>CT</b>	
150 Elyseo	00 - 04	<b>CT</b>	
150 Elystar	03 - 04	<b>CT</b>	
250 Geopolis (AJP cal.)	06 - 11	<b>CT</b>	
400 Geopolis (AJP cal.)	07 - 12	<b>CT</b>	
<b>PIAGGIO VESPA</b>			
BV 200	05 - 05	<b>CT</b>	
<b>SHERCO</b>			
SE 50 Enduro	07 - 07	<b>HF</b>	



<b>SHERCO</b>			
SM 50 Supermotard	07 - 13	<b>HF</b>	
<b>YAMAHA</b>			
DT 50 X Supermotard	04 - 08	<b>HF</b>	
TZR 50	03 - 04	<b>HF</b>	

### SBS 169

### Recommended compound



<b>YAMAHA</b>			
XP 500 TMAX	01 - 03	<b>MS</b>	
XP 530 TMAX	12 - 19	<b>MS</b>	
XP 530 TMAX DX	17 - 19	<b>MS</b>	
XP 530 TMAX Iron Max	15 - 19	<b>MS</b>	
XP 530 TMAX SX	17 - 19	<b>MS</b>	
560 TMAX	20 - 20	<b>MS</b>	
560 TMAX Tech Max	20 - 20	<b>MS</b>	

STREET  
AMERICAN  
SCOOTER

HF • HS • LS  
H.HF • H.CT • H.HS • H.LS  
HF • CT • MS

RACING  
OFF ROAD  
ATV

RST • DC • DCC • DS-1 • DS-2 • RQ  
SI • RSI • CS  
ATS • SI • RSI • PSI

Drawings 1:1

Available compounds

HF • CT

SBS 168

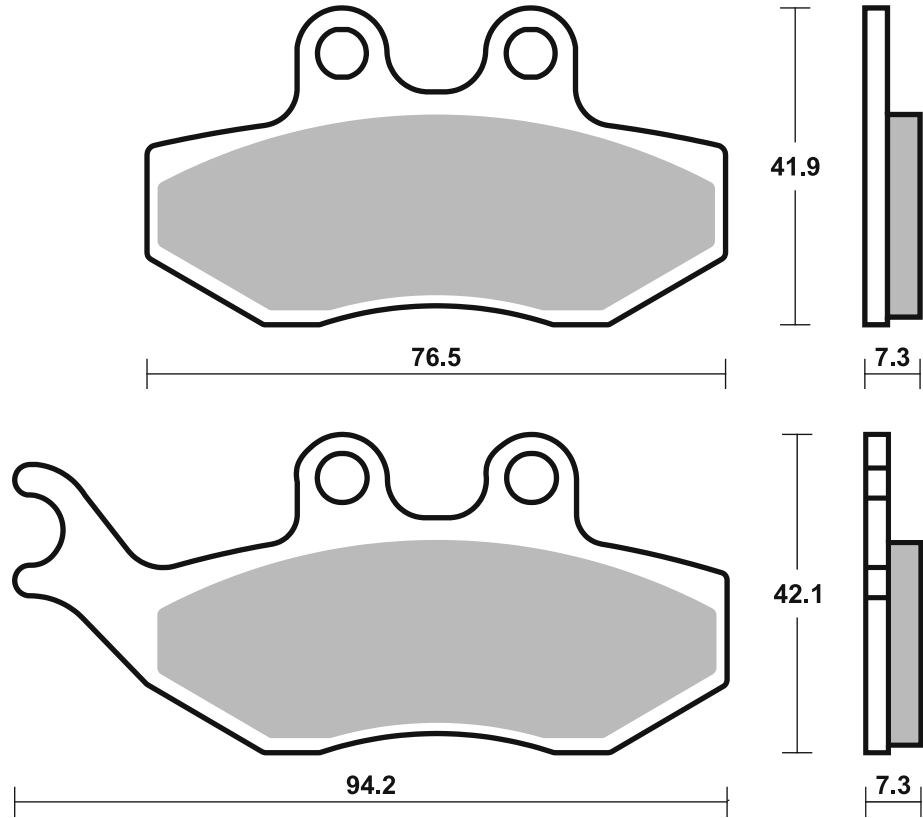

Available compounds

HF • CT • MS

SBS 169

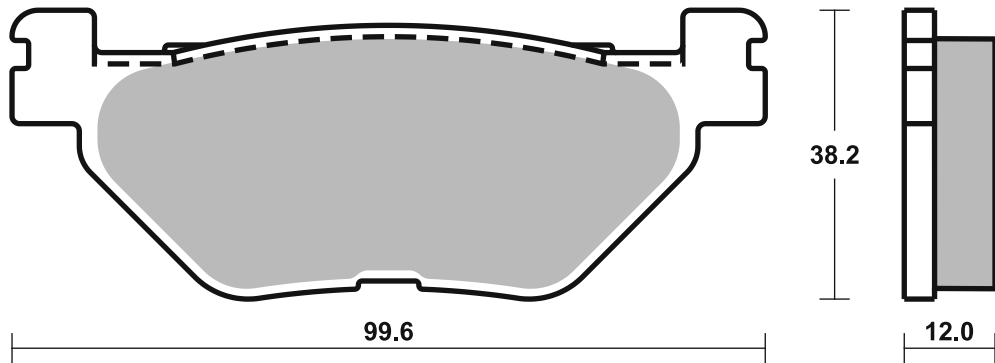

**Applications****SBS 170****Recommended compound**

YAMAHA			
YP	400 Majesty	04 - 04	MS
XP	500 TMAX	01 - 03	MS

**SBS 171****Recommended compound**

KYMCO			
	250 Grand Dink	01 - 10	MS
SYM			
	125 Voyager	05 - 05	CT
	250 Joymax	07 - 10	MS
	250 Voyager	05 - 05	MS
RV	250 Efi	10 - 10	MS
	300 Joymax Evo	10 - 12	MS
	300 Joymax Sport	16 - 17	MS
GTS	300	09 - 13	MS

**SBS 172****Recommended compound**

KYMCO			
	250 Grand Dink	01 - 10	MS

Brake Pad 1:1 Drawings, Compounds, Fitments



STREET  
AMERICAN  
SCOOTER

HF • HS • LS  
H.HF • H.CT • H.HS • H.LS  
HF • CT • MS

RACING  
OFF ROAD  
ATV

RST • DC • DCC • DS-1 • DS-2 • RQ  
SI • RSI • CS  
ATS • SI • RSI • PSI

Drawings 1:1

Available compounds

HF • CT • MS

SBS 170

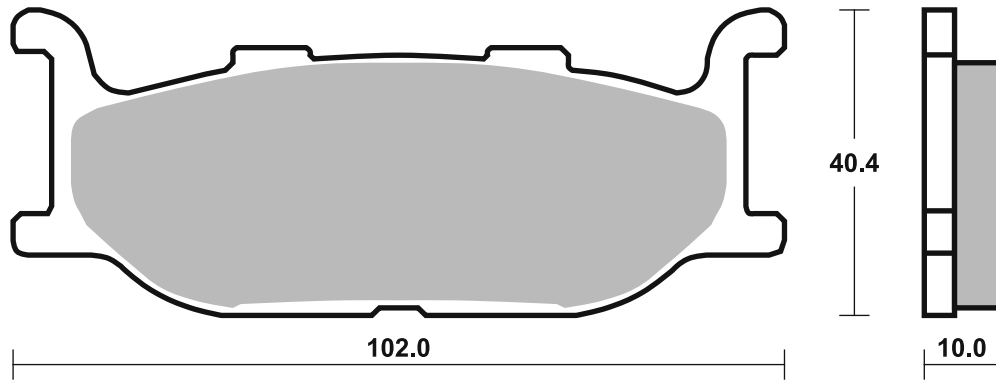

Available compounds

HF • CT • MS

SBS 171

1 set = 4 pcs.

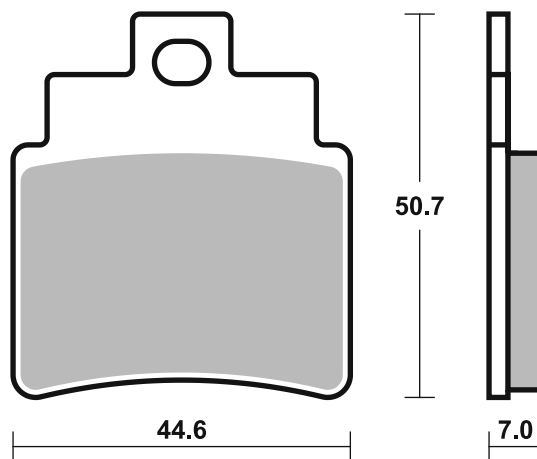

Available compounds

HF • CT • MS

SBS 172

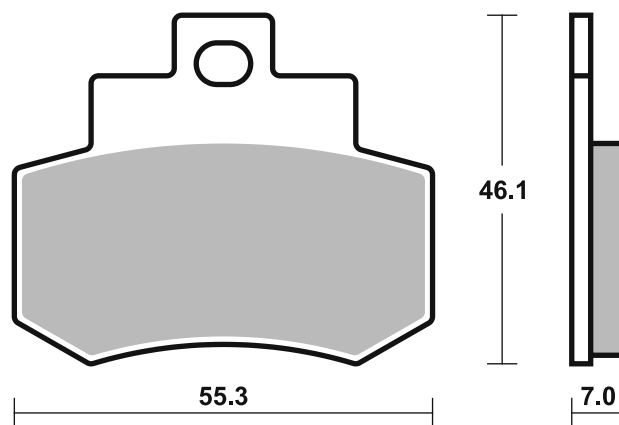



STREET  
AMERICAN  
SCOOTER

HF • HS • LS  
H.HF • H.CT • H.HS • H.LS  
HF • CT • MS

RACING  
OFF ROAD  
ATV

RST • DC • DCC • DS-1 • DS-2 • RQ  
SI • RSI • CS  
ATS • SI • RSI • PSI

Available compounds

HF

SBS 173

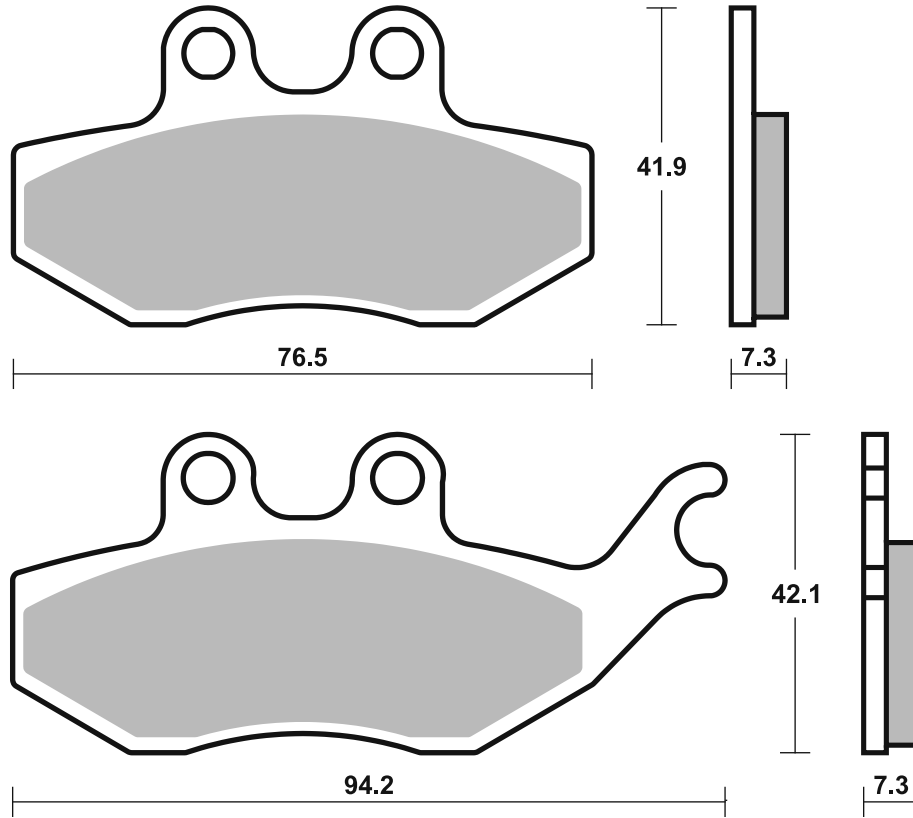

Available compounds

HF • CT • MS

SBS 174

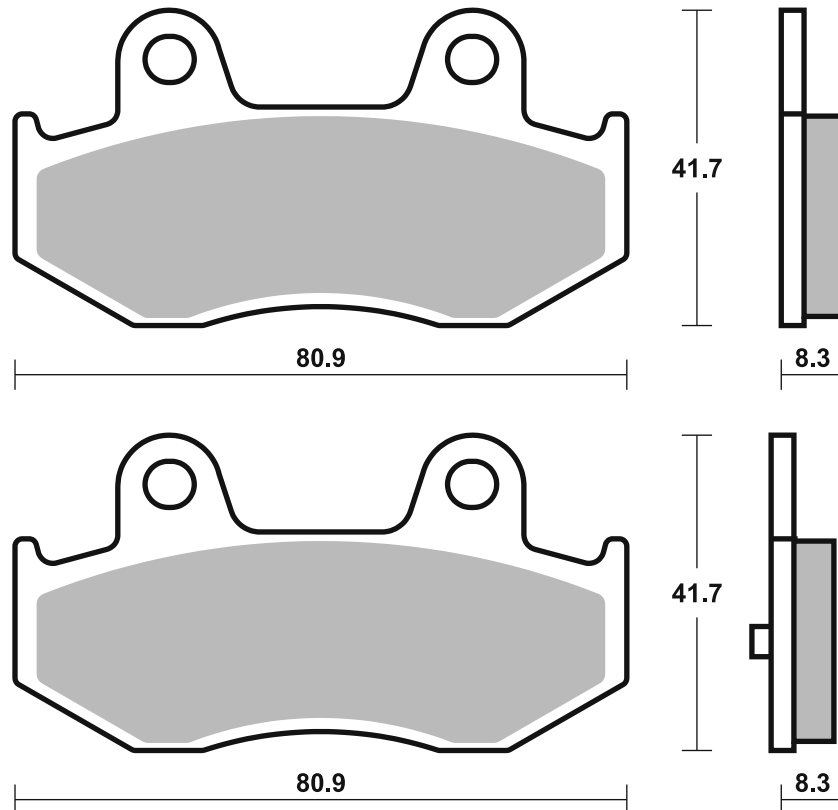



STREET  
AMERICAN  
SCOOTER

HF • HS • LS  
H.HF • H.CT • H.HS • H.LS  
HF • CT • MS

RACING  
OFF ROAD  
ATV

RST • DC • DCC • DS-1 • DS-2 • RQ  
SI • RSI • CS  
ATS • SI • RSI • PSI

Drawings 1:1

Available compounds

HF • CT • MS

SBS 175

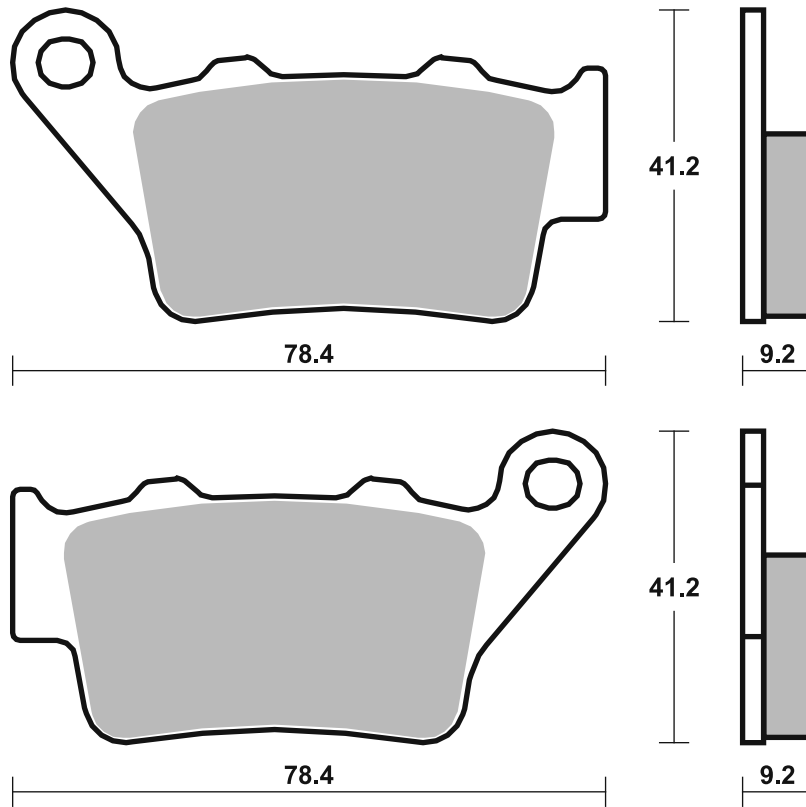

Available compounds

HF • CT • MS

SBS 176

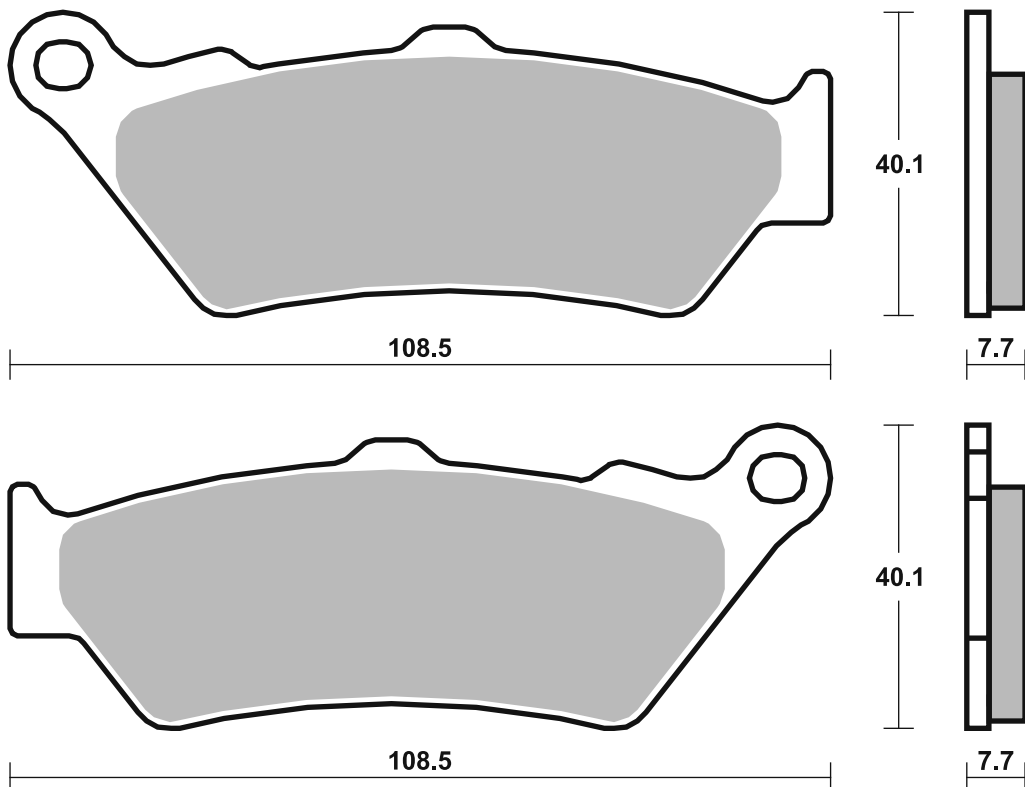



APRILIA			
	50 Sport City One	08 - 12	HF
	125 Sportcity (Hengtong cal.)	04 - 12	CT
SR	125 Max	12 - 17	CT CT
SR	125 Sport City One	12 - 12	CT
SR	300 Max	12 - 19	MS MS
SRV	850	12 - 19	MS

DERBI			
	50 Boulevard	09 - 13	HF

GILERA			
	50 Runner PJ	06 - 11	HF
	50 Runner SP	06 - 12	HF
	125 Nexus	07 - 12	CT CT

FX	125 Runner (Hengtong cal.)	00 - 05	CT
----	-------------------------------	---------	----

FX	125 Runner SP (Hengtong cal.)	00 - 03	CT
----	----------------------------------	---------	----

ST	125 Runner	08 - 13	CT
----	------------	---------	----

VX	125 Runner 4T (Hengtong cal.)	01 - 12	CT
----	----------------------------------	---------	----

FXR	180 Runner (Hengtong cal.)	00 - 03	CT
-----	-------------------------------	---------	----

FXR	180 Runner SP (Hengtong cal.)	00 - 00	CT
-----	----------------------------------	---------	----

VXR	180 Runner	01 - 08	CT
-----	------------	---------	----

VXR	180 Runner 4T (Hengtong cal.)	01 - 08	CT
-----	----------------------------------	---------	----

ST	200 Runner	08 - 11	CT
----	------------	---------	----

VXR	200 Runner 4T (Hengtong cal.)	01 - 09	CT
-----	----------------------------------	---------	----

	250 Nexus	07 - 08	MS MS
--	-----------	---------	-------

GP	800	08 - 15	MS
----	-----	---------	----

PEUGEOT			
	50 CityStar	14 - 16	HF
	125 Active	13 - 13	CT
	125 CityStar	11 - 15	CT
	125 Geopolis	06 - 09	CT
RS	125 Geopolis	10 - 13	CT
	200 CityStar	13 - 16	CT
	250 Satelis	06 - 11	MS MS

PIAGGIO VESPA			
	50 Fly	05 - 17	HF
	50 Primavera	14 - 17	HF
	50 Sprint	15 - 17	HF
TPH	50 2T	11 - 17	HF



PIAGGIO VESPA			
	100 Fly	07 - 15	HF
	100 Zip	07 - 10	HF
	125 946	14 - 16	CT
	125 Beverly	02 - 09	CT CT
	125 Carnaby	08 - 11	CT CT
	125 Fly	05 - 13	CT
	125 Primavera	14 - 16	CT
	125 Primavera 70	16 - 16	CT
	125 Sprint	16 - 17	CT
	125 Sprint S	17 - 17	CT
	125 Sprint Sport	17 - 17	CT
	125 X10 Executive	13 - 15	MS
	125 X7	08 - 12	CT
	125 X8	04 - 10	CT
	125 X9	04 - 11	CT
	125 X9 Evolution	06 - 11	CT
	125 Xevo	08 - 13	CT
GT	125 L	04 - 09	CT
GTS	125	07 - 10	CT
GTS	125 Super	10 - 13	CT
GTS	125 Super i.e.	15 - 16	CT
GTS	125 Supersport	13 - 13	CT
GTS	125 Touring	18 - 19	CT
GTV	125	08 - 09	CT
GTX	125 SuperHexagon (Hengtong cal.) (11" wheels)	00 - 00	CT
GTX	125 SuperHexagon (Hengtong cal.) (12" wheels)	01 - 03	CT
	150 Fly	06 - 07	CT
	150 Primavera	14 - 17	CT
	150 X8 Street	06 - 08	CT
GTX	180 SuperHexagon (Hengtong cal.) (11" wheels)	00 - 00	CT
GTX	180 SuperHexagon (Hengtong cal.) (12" wheels)	01 - 03	CT
	200 Beverly	02 - 03	CT CT
	200 Carnaby	08 - 12	CT CT
	200 X8	04 - 05	CT CT
BV	200	02 - 05	CT CT
BV	200	05 - 05	CT
GT	200 L	04 - 09	CT
	250 Beverly	07 - 08	MS MS
	250 GT 60	06 - 07	MS
	250 X7	08 - 09	MS
	250 X8	06 - 09	MS



PIAGGIO VESPA			
	250 X9	05 - 10	MS
	250 Xevo	08 - 11	MS
BV	250	06 - 06	MS MS
GTS	250	06 - 07	MS
GTV	250	08 - 10	MS
	300 Beverly hpe	22 - 22	MS
	300 Beverly i.e.	11 - 19	MS
	300 Beverly Tourer	07 - 08	MS MS
	300 Carnaby Cruiser	10 - 13	MS MS
	300 Sei Giorni	18 - 19	MS
	300 X7 Evo i.e.	11 - 13	MS
GTS	300 i.e.	12 - 15	MS
GTS	300 Super	09 - 12	MS
GTS	300 Super Notte	19 - 20	MS
GTS	300 Super Sport i.e.	11 - 15	MS
GTS	300 Touring ABS	17 - 17	MS
GTS	300 Touring i.e.	11 - 12	MS
GTS	300 Yacht Club	18 - 18	MS
GTV	300 i.e.	11 - 15	MS
	350 Beverly S	14 - 19	MS
	350 Beverly Sport Touring ie ABS	12 - 19	MS
	350 X10 Executive	13 - 16	MS
BV	350	12 - 17	MS
	400 Beverly hpe S	22 - 22	MS
	400 MP3 iE	07 - 10	MS
	400 MP3 LT iE	09 - 10	MS
	400 MP3 LT Touring	11 - 12	MS
	400 MP3 Touring	11 - 12	MS
	400 X8	07 - 08	MS MS
	400 Xevo	08 - 11	MS MS
	500 MP3	10 - 10	MS
	500 MP3 LT Touring Business	11 - 13	MS
	500 MP3 LT Touring Business ABS	14 - 15	MS
	500 MP3 LT Touring Sport	11 - 13	MS
	500 MP3 LT Touring Sport ABS	14 - 15	MS
	500 MP3 Touring Business	11 - 12	MS
	500 MP3 Touring Sport	11 - 12	MS
	500 X10 Executive	13 - 15	MS



LAVERDA			
	125 Phoenix	01 - 04	CT
	150 Phoenix	01 - 04	CT
	200 Phoenix	01 - 04	CT

SYM			
RS	50	05 - 09	HF
RS21	50	02 - 09	HF
	125 Euro MX	03 - 04	CT
	125 Joyride	01 - 09	CT
	125 Joyride Evo	10 - 12	CT
	125 Joyride S	16 - 17	CT
RS	125	05 - 06	CT
RS21	125 , R	02 - 02	CT



SYM			
VS	125	09 - 13	CT
	150 Euro MX	03 - 06	CT
	150 Husky ADV	22 - 22	CT
	150 Joyride	01 - 06	CT
RS	150	05 - 06	CT
	200 Joyride	01 - 08	CT
	200 Joyride S	16 - 17	CT
	300 Joyride	22 - 22	CT



STREET  
AMERICAN  
SCOOTER

HF • HS • LS  
H.HF • H.CT • H.HS • H.LS  
HF • CT • MS

RACING  
OFF ROAD  
ATV

RST • DC • DCC • DS-1 • DS-2 • RQ  
SI • RSI • CS  
ATS • SI • RSI • PSI

Drawings 1:1

Available compounds

HF • CT • MS

SBS 177

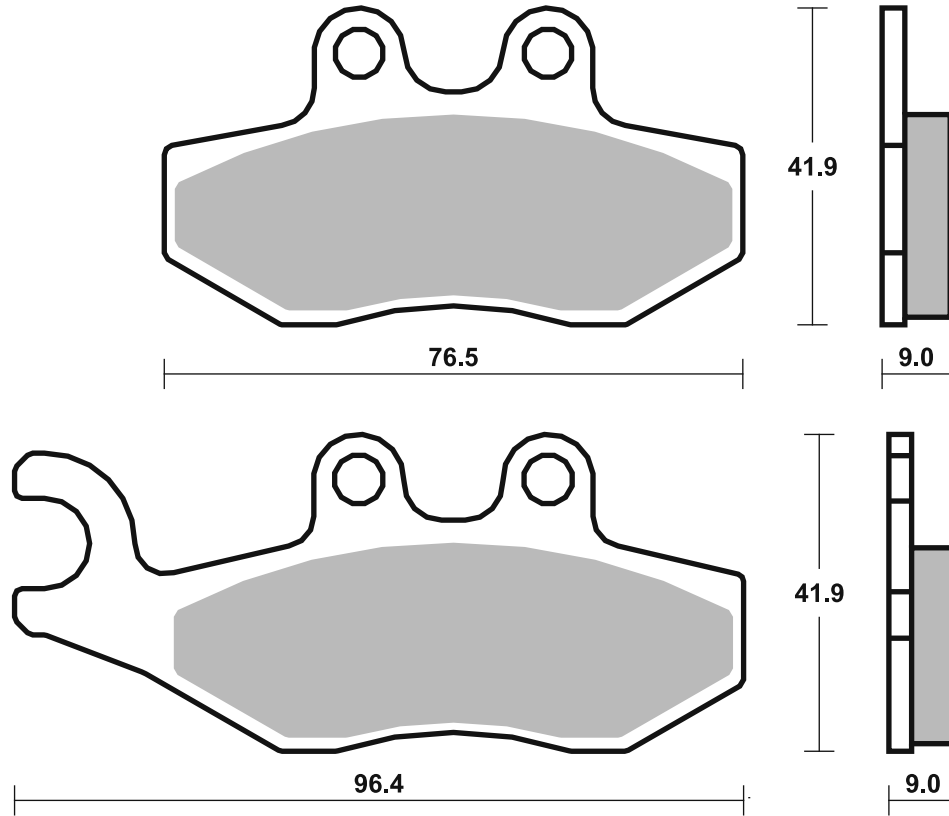

Available compounds

HF • CT

SBS 178

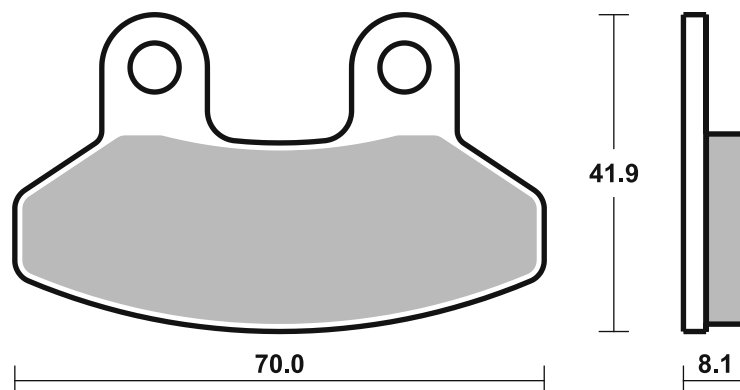

Dimensions in mm / Dimensions en mm  
1" = 25.4 mm, 1 mm = 0.04"

Brake Pad 1:1 Drawings,  
Compounds, Fitments

**SBS 179**

**Recommended compound**



**APRILIA**

500 Atlantic          02 - 05   **MS**

**SBS 180**

**Recommended compound**



**HONDA**

ANF 125 i Innova          07 - 11   **CT**  
ANF 125 Innova          03 - 06   **CT**

**MALAGUTI**

GP 125 Spectre          21 - 23   **CT**

**RIEJU**

RS2 50 NKD          06 - 10   **HF**

STREET  
AMERICAN  
SCOOTER

HF • HS • LS  
H.HF • H.CT • H.HS • H.LS  
HF • CT • MS

RACING  
OFF ROAD  
ATV

RST • DC • DCC • DS-1 • DS-2 • RQ  
SI • RSI • CS  
ATS • SI • RSI • PSI

Drawings 1:1

Available compounds

HF • CT • MS

SBS 179

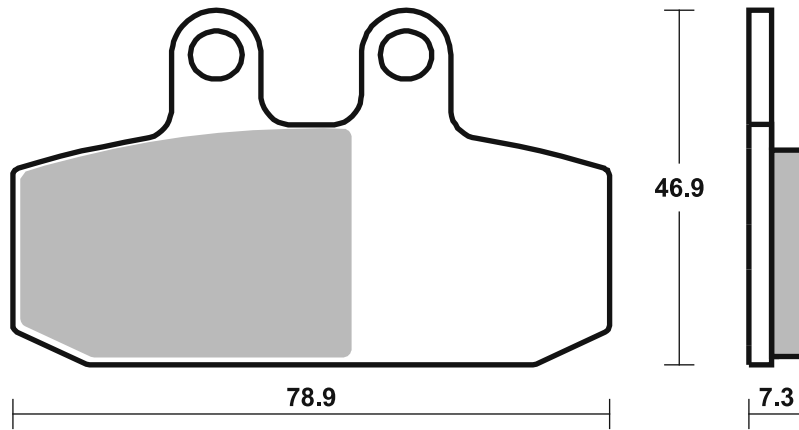
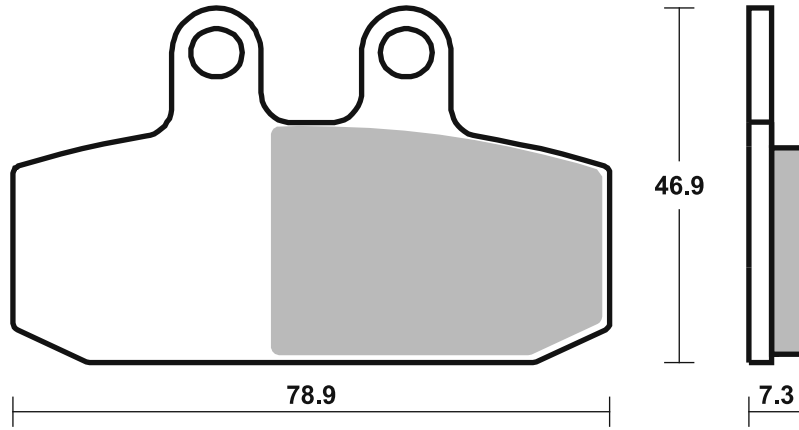

Available compounds

HF • CT

SBS 180

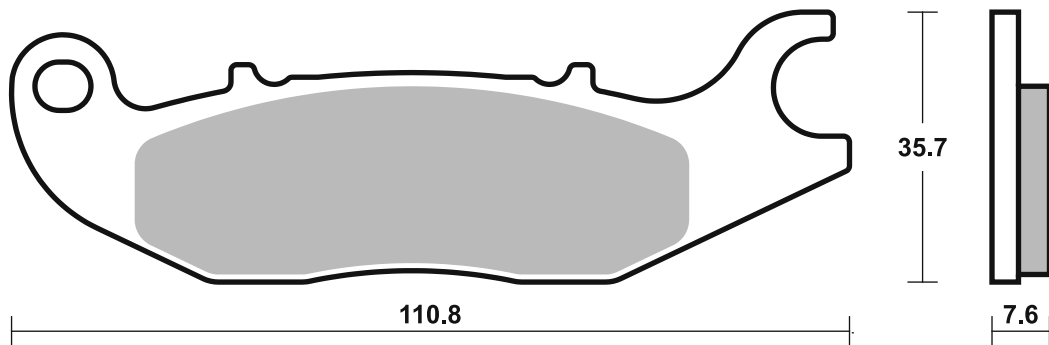
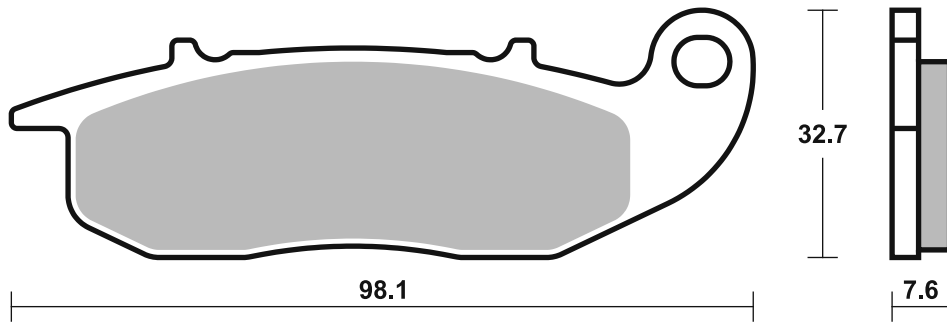

Applications

SBS 181 Recommended compound



YAMAHA			
VP	125 X-City	08 - 13	CT
YP	125 XMAX	10 - 23	CT
YP	125 XMAX ABS	11 - 16	CT
YP	125 XMAX Business ABS	11 - 13	CT
YP	125 XMAX Sport Ed.	11 - 13	CT
VP	250 X-City	07 - 09	MS
YP	250 XMAX	10 - 16	MS
VP	300 Versity	05 - 06	MS
YP	400 R XMAX	13 - 16	MS
YP	400 RA XMAX	14 - 16	MS

SBS 182 Recommended compound



SUZUKI			
AN	400 Burgman	07 - 24	MS
AN	650 A Burgman Executive	04 - 20	MS
AN	650 Burgman	02 - 19	MS
AN	650 Z Burgman Executive	13 - 19	MS

STREET  
AMERICAN  
SCOOTER

HF • HS • LS  
H.HF • H.CT • H.HS • H.LS  
HF • CT • MS

RACING  
OFF ROAD  
ATV

RST • DC • DCC • DS-1 • DS-2 • RQ  
SI • RSI • CS  
ATS • SI • RSI • PSI

Drawings 1:1

Available compounds

HF • CT • MS

SBS 181

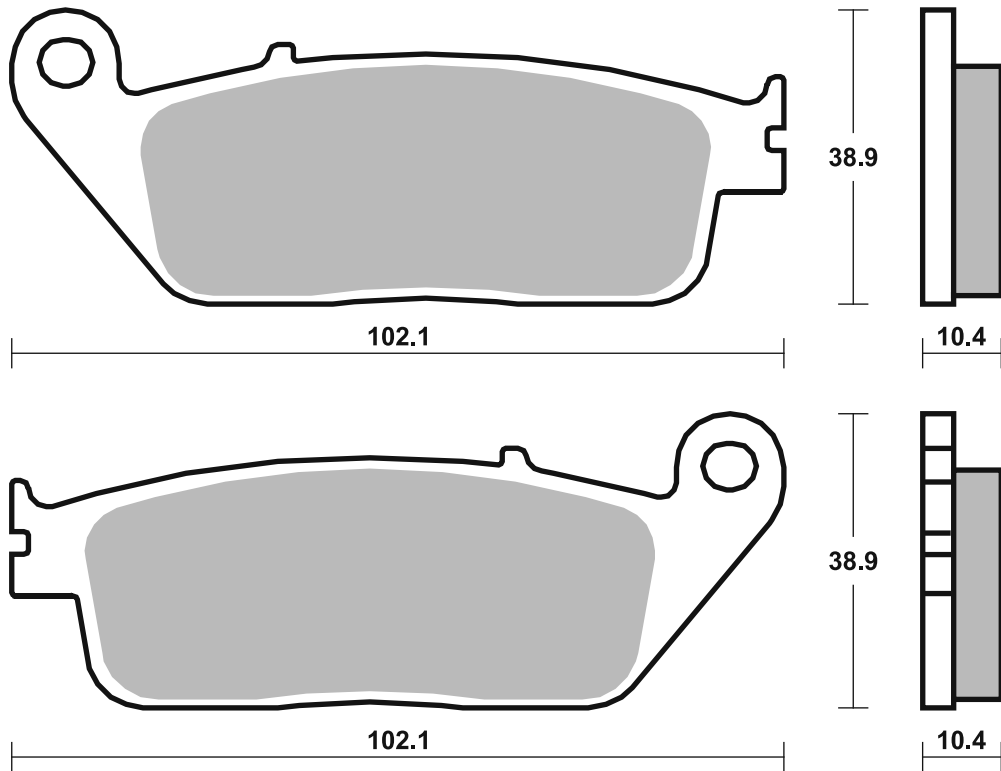

Available compounds

HF • CT • MS

SBS 182

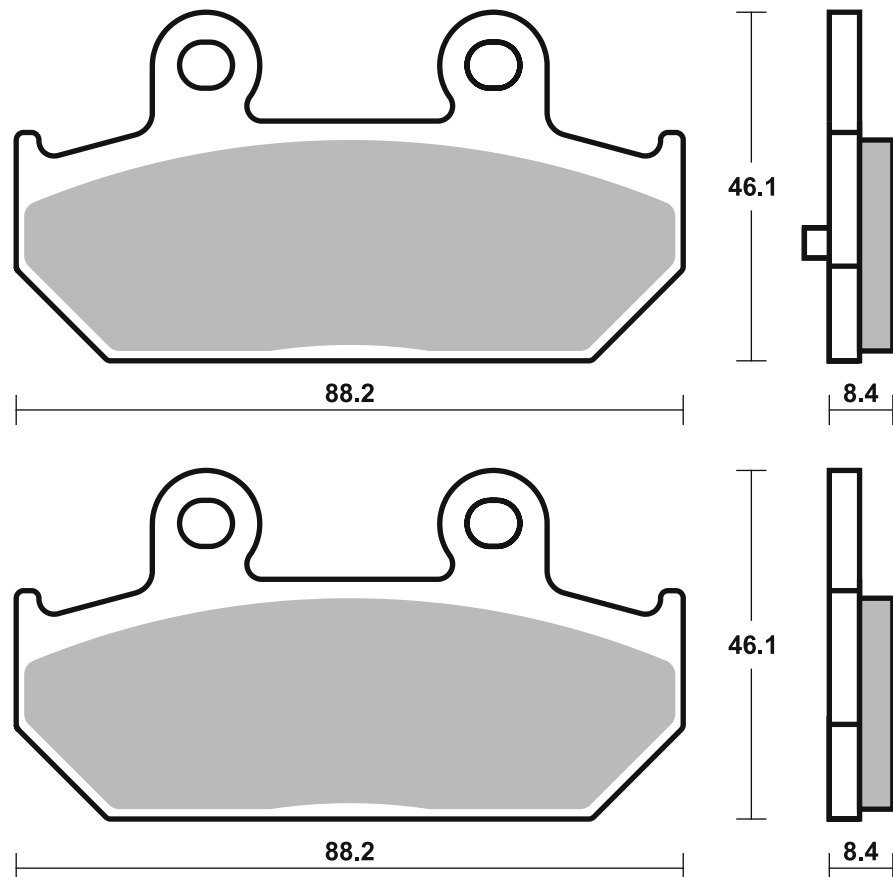

Dimensions in mm / Dimensions en mm  
1" = 25.4 mm, 1 mm = 0.04"

## SBS 183

## Recommended compound



<b>BMW</b>			
C	Evolution	12 - 18	<b>MS MS</b>
C	600 Sport	12 - 15	<b>MS MS</b>
C	650 GT	12 - 21	<b>MS MS</b>
C	650 Sport	16 - 20	<b>MS MS</b>
<b>DAELIM</b>			
	125 S2	06 - 08	<b>CT</b>
	250 S2	06 - 10	<b>CT</b>
<b>HONDA</b>			
NSS	125 Forza	15 - 19	<b>CT</b>
SH	125	13 - 20	<b>CT</b>
SH	125 i Vetro	24 - 24	<b>HF</b>
SH	150	13 - 18	<b>CT</b>
SH	150 i Vetro	24 - 24	<b>HF</b>
CN	250 Helix (Fusion)	93 - 03	<b>MS</b>
NSS	300 Forza	18 - 20	<b>MS</b>
SH	300 i SH30	15 - 18	<b>MS</b>
	350 Forza	21 - 23	<b>MS</b>
ADV	350	22 - 24	<b>MS</b>
SH	350	21 - 22	<b>MS</b>
<b>KAWASAKI</b>			
J	125	15 - 19	<b>CT</b>
J	300	14 - 19	<b>MS</b>
<b>KYMCO</b>			
	50 New G-Dink	12 - 13	<b>HF</b>
	125 Downtown i	10 - 14	<b>CT</b>
	125 K-XCTi	13 - 14	<b>CT</b>
	125 New G-Dink	12 - 14	<b>CT</b>



<b>KYMCO</b>			
	125 Super Dink	10 - 15	<b>CT</b>
	200 Downtown i	10 - 15	<b>CT</b>
	250 Xciting	04 - 09	<b>MS MS</b>
	250 Xciting	06 - 09	<b>MS</b>
	300 Downtown i	10 - 15	<b>MS</b>
	300 New G-Dink	12 - 16	<b>MS</b>
	300 People GTi	10 - 11	<b>MS</b>
	300 Xciting Ri	08 - 14	<b>MS</b>
	500 Xciting	04 - 15	<b>MS</b>
	500 Xciting i Evo ABS	11 - 13	<b>MS</b>
	500 Xciting R ABS	09 - 13	<b>MS</b>
	700 MyRoad, ABS	09 - 15	<b>MS</b>
<b>PEUGEOT</b>			
	125 Satelis ABS	04 - 08	<b>CT</b>
	300 Geopolis GT	14 - 16	<b>MS</b>
	400 Geopolis GT	14 - 15	<b>MS</b>
	400 Geopolis RS	08 - 16	<b>MS</b>
	400 Satelis i	14 - 16	<b>MS</b>
	500 Satelis	07 - 11	<b>MS</b>
	600 Satelis ABS	04 - 12	<b>CT</b>
<b>SUZUKI</b>			
AN	650 A Burgman		
	Executive	04 - 20	<b>MS</b>
AN	650 Burgman	02 - 19	<b>MS</b>
AN	650 Z Burgman		
	Executive	13 - 19	<b>MS</b>
<b>ZONTES</b>			
	310 M	21 - 22	<b>MS</b>

## SBS 184

## Recommended compound



<b>HONDA</b>			
FJS	400 Silverwing	06 - 08	<b>MS</b>
SW-T	400	09 - 13	<b>MS</b>
SW-T	400 ABS	09 - 14	<b>MS</b>
FJS	600 Silverwing	01 - 18	<b>MS</b>
SW-T	600	11 - 13	<b>MS</b>



STREET  
AMERICAN  
SCOOTER

HF • HS • LS  
H.HF • H.CT • H.HS • H.LS  
HF • CT • MS

RACING  
OFF ROAD  
ATV

RST • DC • DCC • DS-1 • DS-2 • RQ  
SI • RSI • CS  
ATS • SI • RSI • PSI

Available compounds

HF • CT • MS

SBS 183

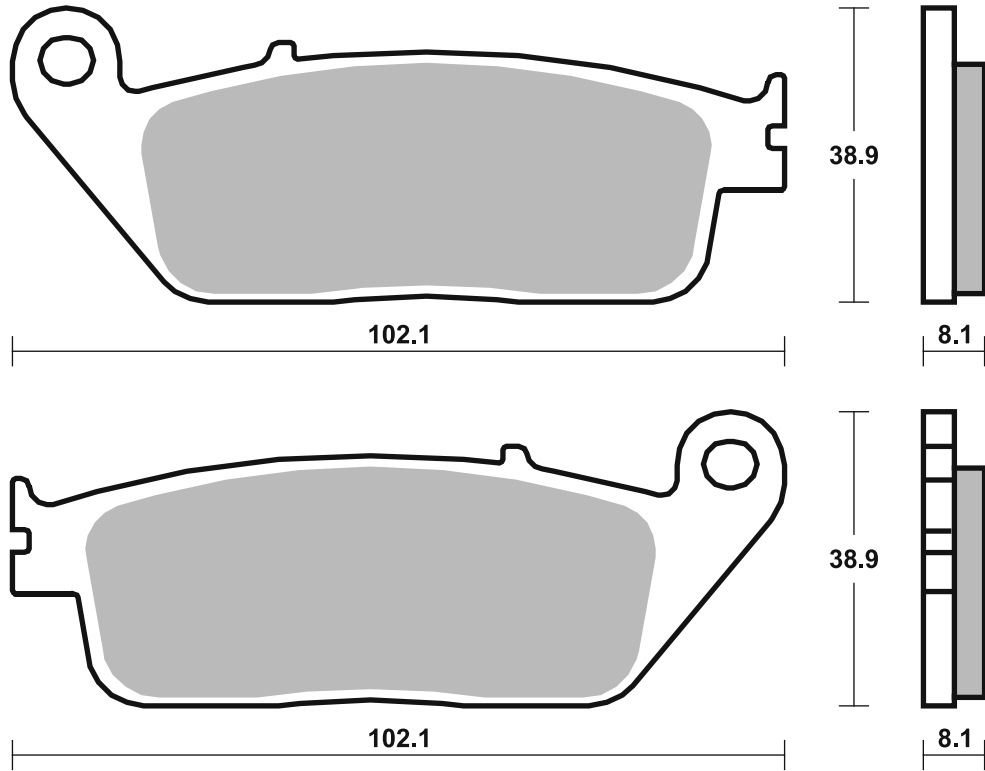

Available compounds

MS

SBS 184

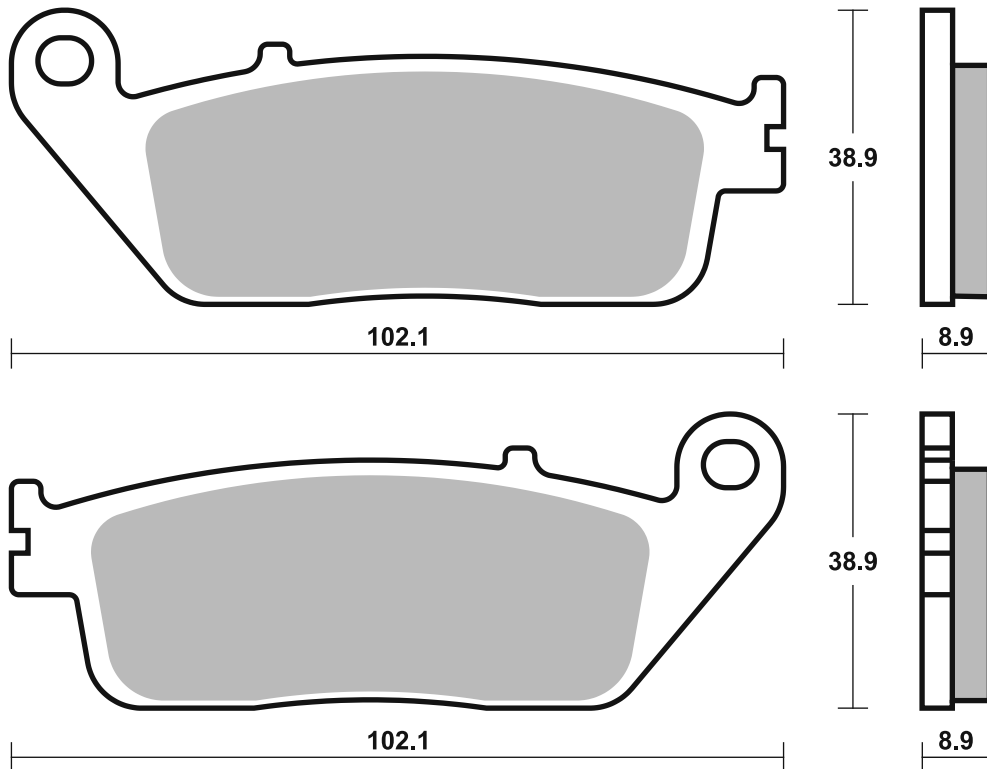

## Applications

### SBS 185

#### Recommended compound



#### YAMAHA

YP	400 Majesty	04 - 13	MS
XP	500 TMAX	04 - 11	MS
XP	500 TMAX Tech Max	11 - 11	MS

### SBS 186

#### Recommended compound



#### APRILIA

RX	50	06 - 14	HF
SX	50	06 - 13	HF

#### MOTORHISPANIA

RYZ	50 Supermotard	05 - 10	HF
-----	----------------	---------	----

STREET  
AMERICAN  
SCOOTER

HF • HS • LS  
H.HF • H.CT • H.HS • H.LS  
HF • CT • MS

RACING  
OFF ROAD  
ATV

RST • DC • DCC • DS-1 • DS-2 • RQ  
SI • RSI • CS  
ATS • SI • RSI • PSI

Available compounds

HF • CT • MS

SBS 185

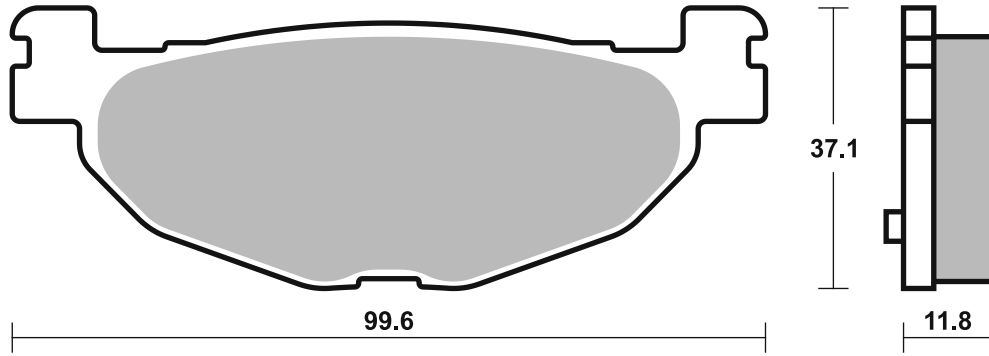

Available compounds

HF

SBS 186

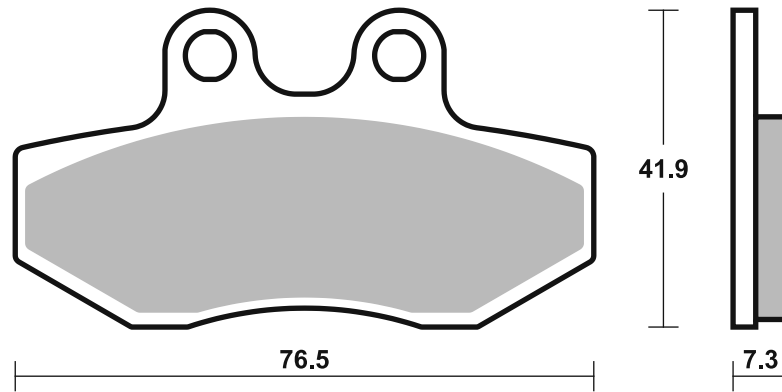

## Applications

### SBS 187

#### Recommended compound



<b>APRILIA</b>			
SR	125 GT	21 - 23	<b>CT</b>
SR	200 GT	21 - 23	<b>CT</b>
<b>PIAGGIO VESPA</b>			
	125 Medley	16 - 19	<b>CT</b>
	125 Medley S	17 - 19	<b>CT</b>
	125 MP3 Efi	08 - 11	<b>CT</b>
	125 MP3 Hybrid	09 - 12	<b>CT</b>
	125 MP3 Yourban	11 - 12	<b>CT</b>
	125 X10 Executive	13 - 15	<b>MS MS</b>
	125 X7	08 - 12	<b>CT</b>
	125 X9	04 - 11	<b>CT</b>
	125 X9 Evolution	06 - 11	<b>CT</b>
	125 Xevo	08 - 13	<b>CT</b>
	150 Medley	16 - 19	<b>CT</b>
	250 MP3 Efi	08 - 09	<b>MS</b>
	250 MP3 LT iE	09 - 09	<b>MS</b>
	250 X7	08 - 09	<b>MS</b>
	250 X9	05 - 10	<b>MS</b>
	250 Xevo	08 - 11	<b>MS</b>
	300 Beverly i.e.	11 - 19	<b>MS</b>
	300 MP3 Hybrid	11 - 12	<b>MS</b>
	300 MP3 Hybrid iE	11 - 19	<b>MS</b>
	300 MP3 iE	10 - 19	<b>MS</b>
	300 MP3 LT	13 - 19	<b>MS</b>
	300 MP3 LT Business	13 - 19	<b>MS</b>
	300 MP3 LT iE ABS	14 - 19	<b>MS</b>
	300 MP3 LT Sport ABS	14 - 19	<b>MS</b>
	300 MP3 LT Touring	11 - 12	<b>MS</b>
	300 MP3 Touring	11 - 12	<b>MS</b>
	300 MP3 Yourban iE	11 - 19	<b>MS</b>



<b>PIAGGIO VESPA</b>			
	300 X7 Evo i.e.	11 - 13	<b>MS</b>
	350 Beverly S	14 - 19	<b>MS</b>
	350 Beverly Sport		
	Touring ie	12 - 19	<b>MS</b>
	350 Beverly Sport		
	Touring ie ABS	12 - 19	<b>MS</b>
	350 X10 Executive	13 - 16	<b>MS MS</b>
BV	350	12 - 17	<b>MS</b>
	400 Beverly hpe S	22 - 22	<b>MS</b>
	400 X8	07 - 08	<b>MS</b>
	400 Xevo	08 - 11	<b>MS</b>
	500 X10 Executive	13 - 15	<b>MS MS</b>

### SBS 188

#### Recommended compound



<b>BETA</b>			
	50 AJP Caliper		
	incl. pin/spring	90 - 19	<b>HF</b>
<b>CAGIVA</b>			
	50 AJP Caliper		
	incl. pin/spring	90 - 19	<b>HF</b>
<b>DERBI</b>			
	50 AJP Caliper		
	incl. pin/spring	90 - 19	<b>HF</b>
<b>GILERA</b>			
	50 AJP Caliper		
	incl. pin/spring	90 - 19	<b>HF</b>
<b>ITALJET</b>			
	50 AJP Caliper		
	incl. pin/spring	90 - 19	<b>HF</b>
<b>MALAGUTI</b>			
	50 AJP Caliper		
	incl. pin/spring	91 - 19	<b>HF</b>
<b>MBK</b>			
	50 AJP Caliper		
	incl. pin/spring	89 - 19	<b>HF</b>
<b>MOTORHISPANIA</b>			
	50 AJP Caliper		
	incl. pin/spring	89 - 19	<b>HF</b>



<b>PEUGEOT</b>			
	50 AJP Caliper		
	incl. pin/spring	89 - 19	<b>HF</b>
<b>PIAGGIO VESPA</b>			
	50 AJP Caliper		
	incl. pin/spring	91 - 19	<b>HF</b>
<b>RIEJU</b>			
	50 AJP Caliper		
	incl. pin/spring	91 - 19	<b>HF</b>
<b>SHERCO</b>			
	50 AJP Caliper		
	incl. pin/spring	91 - 19	<b>HF</b>
<b>SUZUKI</b>			
	50 AJP Caliper		
	incl. pin/spring	91 - 19	<b>HF</b>
<b>YAMAHA</b>			
	50 AJP Caliper		
	incl. pin/spring	91 - 19	<b>HF</b>

STREET  
AMERICAN  
SCOOTER

HF • HS • LS  
H.HF • H.CT • H.HS • H.LS  
HF • CT • MS

RACING  
OFF ROAD  
ATV

RST • DC • DCC • DS-1 • DS-2 • RQ  
SI • RSI • CS  
ATS • SI • RSI • PSI

Drawings 1:1

Available compounds

HF • CT • MS

SBS 187

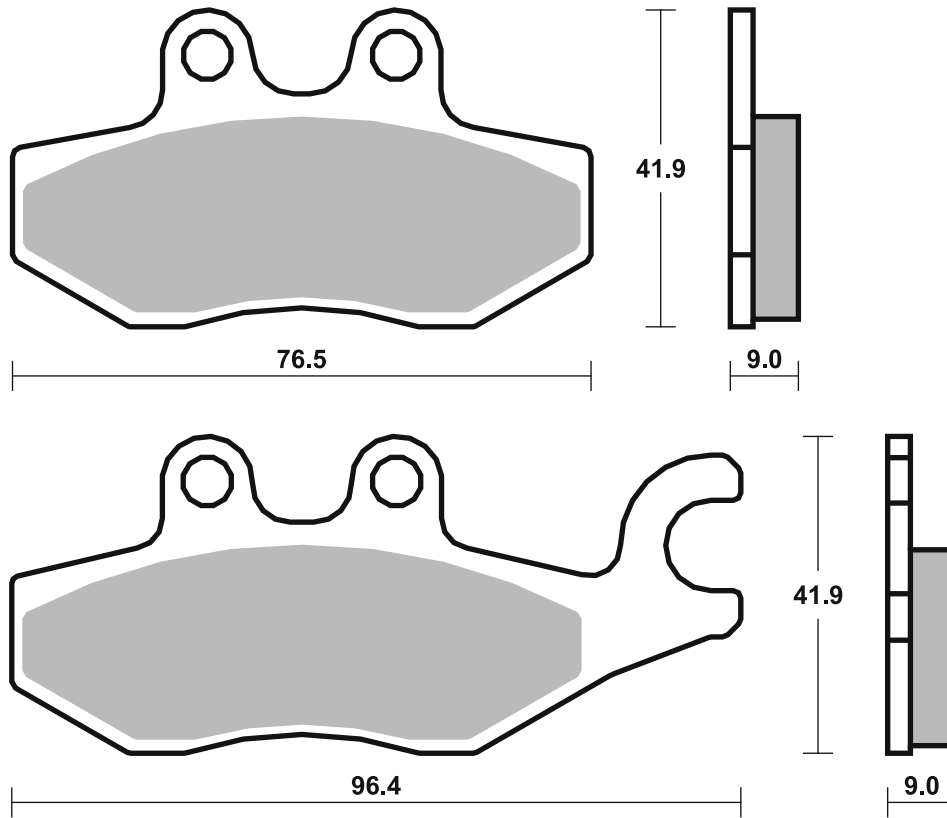

Available compounds

HF

SBS 188

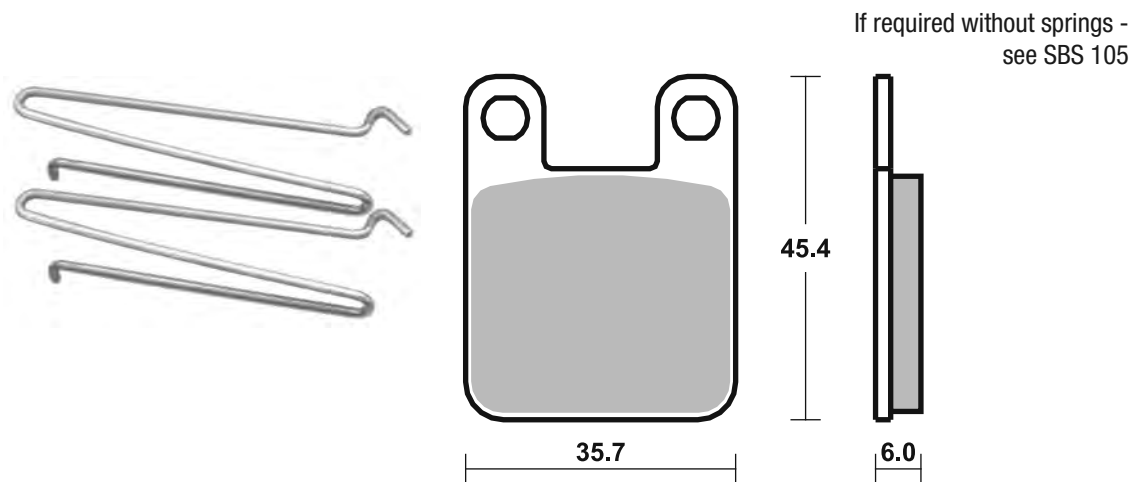



STREET  
AMERICAN  
SCOOTER

HF • HS • LS  
H.HF • H.CT • H.HS • H.LS  
HF • CT • MS

RACING  
OFF ROAD  
ATV

RST • DC • DCC • DS-1 • DS-2 • RQ  
SI • RSI • CS  
ATS • SI • RSI • PSI

Available compounds

MS

SBS 189

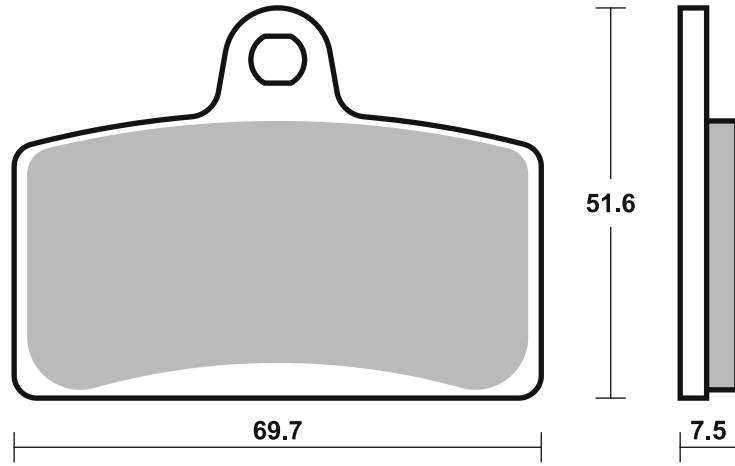

Available compounds

HF • CT • MS

SBS 190

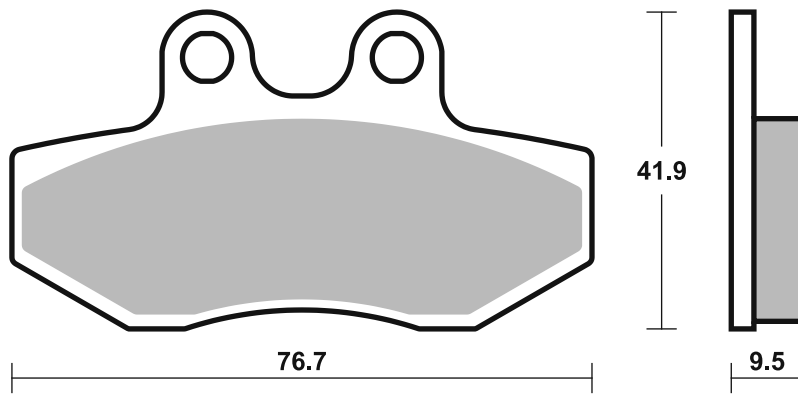

Available compounds

HF • CT • MS

SBS 191

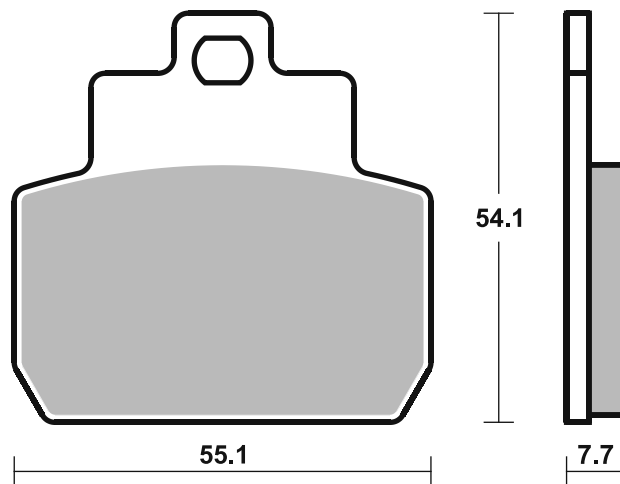



## Applications

### SBS 192

#### Recommended compound



<b>HONDA</b>			
FES	125 S-Wing	07 - 11	<b>CT</b>
SH	125 i	09 - 12	<b>HF</b>
FES	150 S-Wing	07 - 11	<b>CT</b>
SH	150 i	09 - 12	<b>HF</b>
NSS	250	05 - 13	<b>MS</b>
NSS	250 Forza	05 - 13	<b>MS</b>
PS	250	05 - 06	<b>MS</b>
NSS	300 Forza	14 - 17	<b>MS</b>
SH	300 i	07 - 19	<b>MS</b>
SW-T	400	09 - 13	<b>MS</b>
SW-T	400 ABS	09 - 14	<b>MS</b>
FJS	600 Silverwing	09 - 18	<b>MS</b>
SW-T	600	11 - 13	<b>MS</b>
<b>SUZUKI</b>			
UH	125 Burgman	07 - 14	<b>CT</b>
UX	125 SIXteen	08 - 12	<b>CT</b>
UX	150 SIXteen	08 - 16	<b>CT</b>
UH	200	07 - 07	<b>CT</b>
UH	200 Burgman	07 - 13	<b>CT</b>

### SBS 193

#### Recommended compound



<b>HONDA</b>			
FES	125 S-Wing	07 - 11	<b>CT</b>
NSS	125 Forza	15 - 19	<b>CT</b>
SH	125	13 - 20	<b>HF</b>
SH	125 i	09 - 12	<b>HF</b>
SH	125 i Vetro	24 - 24	<b>HF</b>
ADV	150	19 - 21	<b>CT</b>
ADV	150 ABS	20 - 21	<b>CT</b>
FES	150 S-Wing	07 - 11	<b>CT</b>
SH	150	13 - 18	<b>HF</b>
SH	150 i	09 - 12	<b>HF</b>
SH	150 i Vetro	24 - 24	<b>HF</b>
ADV	160	24 - 24	<b>CT</b>
NSS	250	05 - 13	<b>MS</b>
NSS	250 Forza	05 - 13	<b>MS</b>
NSS	300 Forza	14 - 20	<b>MS</b>
SH	300 i	07 - 19	<b>MS</b>
SH	300 i SH30	15 - 18	<b>MS</b>
	350 Forza	21 - 23	<b>MS</b>
ADV	350	22 - 24	<b>MS</b>
SH	350	21 - 22	<b>MS</b>

Brake Pad 1:1 Drawings,  
Compounds, Fitments

STREET  
AMERICAN  
SCOOTER

HF • HS • LS  
H.HF • H.CT • H.HS • H.LS  
HF • CT • MS

RACING  
OFF ROAD  
ATV

RST • DC • DCC • DS-1 • DS-2 • RQ  
SI • RSI • CS  
ATS • SI • RSI • PSI

Drawings 1:1

Available compounds

HF • CT • MS

SBS 192

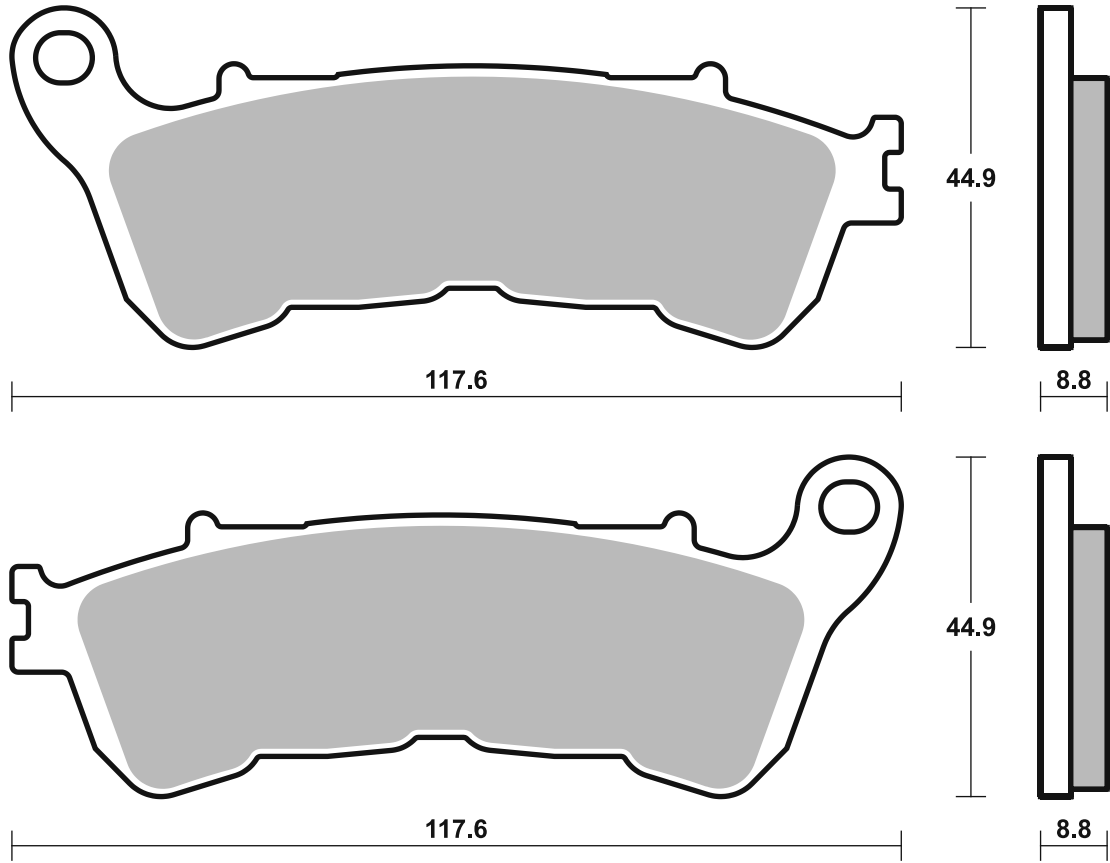

Available compounds

HF • CT • MS

SBS 193

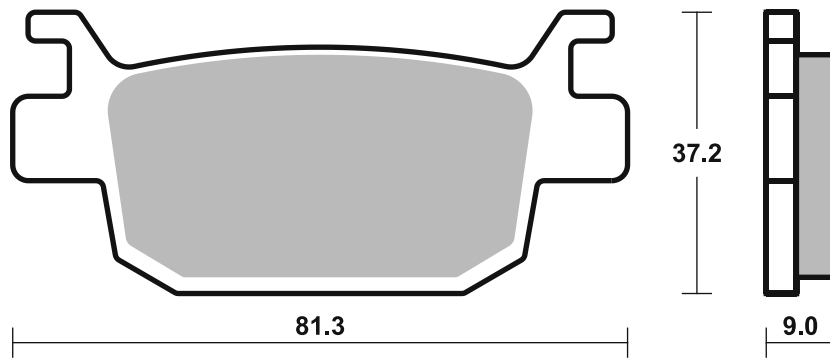

## Applications

### SBS 194 Recommended compound



<b>MBK</b>		
	125 Skycruiser	06 - 14 CT
<b>YAMAHA</b>		
YP	125 XMAX	06 - 09 CT
YP	250 XMAX	05 - 09 MS

### SBS 195 Recommended compound



<b>KYMCO</b>		
	125 K-XCTI	13 - 14 MS
	125 New G-Dink	12 - 14 CT
S	125 People	05 - 08 CT
S	200 People	05 - 07 CT
	250 Xciting	06 - 09 MS
S	250 People	06 - 08 MS
	300 K-XCTI	12 - 15 MS
	300 New G-Dink	12 - 16 MS
	300 People Si	08 - 10 CT
	300 Xciting Ri	08 - 14 MS
	300 X-Town	16 - 20 MS
<b>PEUGEOT</b>		
XP	400	23 - 23 MS
<b>YAMAHA</b>		
YP	400 R XMAX	13 - 16 MS
YP	400 RA XMAX	14 - 16 MS

Brake Pad 1:1 Drawings, Compounds, Fitments

STREET  
AMERICAN  
SCOOTER

HF • HS • LS  
H.HF • H.CT • H.HS • H.LS  
HF • CT • MS

RACING  
OFF ROAD  
ATV

RST • DC • DCC • DS-1 • DS-2 • RQ  
SI • RSI • CS  
ATS • SI • RSI • PSI

Available compounds

HF • CT • MS

SBS 194

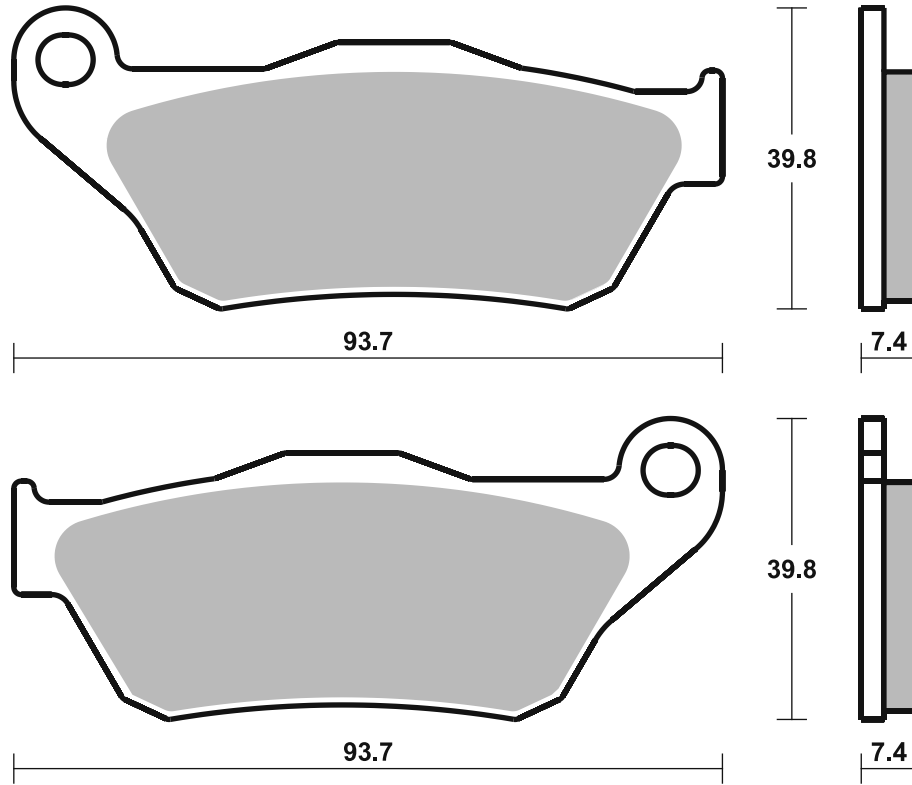

Available compounds

HF • CT • MS

SBS 195

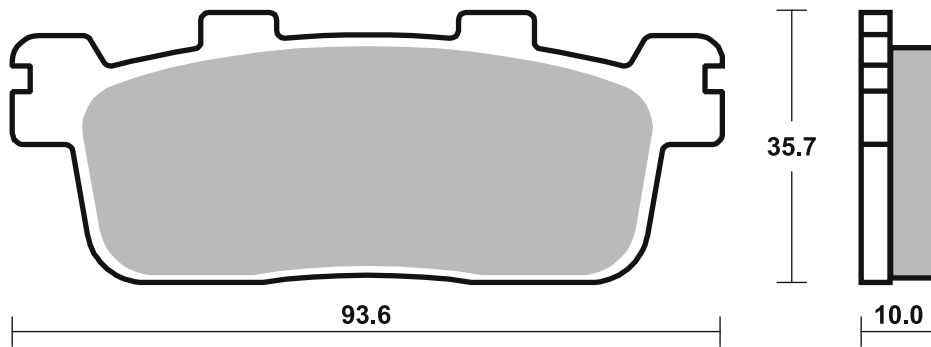

## Applications

### SBS 196 Recommended compound



<b>BENELLI</b>			
	250 Caffenero	08 - 14	<b>MS</b>
<b>SUZUKI</b>			
UH	125 Burgman	07 - 19	<b>CT</b>
UX	125 SIXteen	08 - 12	<b>CT</b>
UX	150 SIXteen	08 - 16	<b>CT</b>
UH	200 Burgman	07 - 18	<b>CT</b>

### SBS 197 Recommended compound



<b>APRILIA</b>			
SX	50 Ltd.	07 - 15	<b>CT</b>
<b>BENELLI</b>			
	125 Caffenero	08 - 11	<b>CT CT</b>
	125 MJ	10 - 10	<b>CT CT</b>
	150 MJ	10 - 10	<b>CT CT</b>
	250 Caffenero	08 - 14	<b>MS</b>
<b>GARELLI</b>			
	200 Xo	12 - 12	<b>CT</b>
<b>KYMCO</b>			
S	250 People	06 - 08	<b>MS</b>
<b>PEUGEOT</b>			
	50 Django Heritage	14 - 16	<b>HF</b>
	125 Django Heritage	14 - 16	<b>CT</b>
	125 Geopolis (Nissin cal.)	07 - 09	<b>CT CT</b>
	125 Vivacity	10 - 16	<b>CT</b>
GT	125 Satelis Sport	11 - 12	<b>CT CT</b>
	150 Django Heritage	14 - 15	<b>CT</b>
	250 Geopolis (Nissin cal.)	06 - 11	<b>MS MS</b>
	300 Geopolis GT	14 - 16	<b>MS</b>
	300 Geopolis Premium (Nissin cal.)	10 - 13	<b>MS MS</b>
	300 Geopolis RS (Nissin cal.)	10 - 14	<b>MS MS</b>
	300 Geostyle (Nissin cal.)	10 - 12	<b>MS MS</b>
	300 Satelis	13 - 16	<b>MS MS</b>
	400 Geopolis (Nissin cal.)	07 - 12	<b>MS MS</b>
	400 Geopolis GT	14 - 15	<b>MS</b>



<b>PEUGEOT</b>			
	400 Geopolis RS	08 - 16	<b>MS</b>
	400 Satelis i	14 - 16	<b>MS</b>
	500 Satelis	07 - 11	<b>MS</b>
<b>PGO</b>			
	125 Libra	10 - 12	<b>CT</b>
	125 X-Hot	10 - 11	<b>CT</b>
<b>SUZUKI</b>			
AN	400 Burgman	07 - 24	<b>MS</b>

STREET  
AMERICAN  
SCOOTER

HF • HS • LS  
H.HF • H.CT • H.HS • H.LS  
HF • CT • MS

RACING  
OFF ROAD  
ATV

RST • DC • DCC • DS-1 • DS-2 • RQ  
SI • RSI • CS  
ATS • SI • RSI • PSI

Drawings 1:1

Available compounds

HF • CT • MS

SBS 196

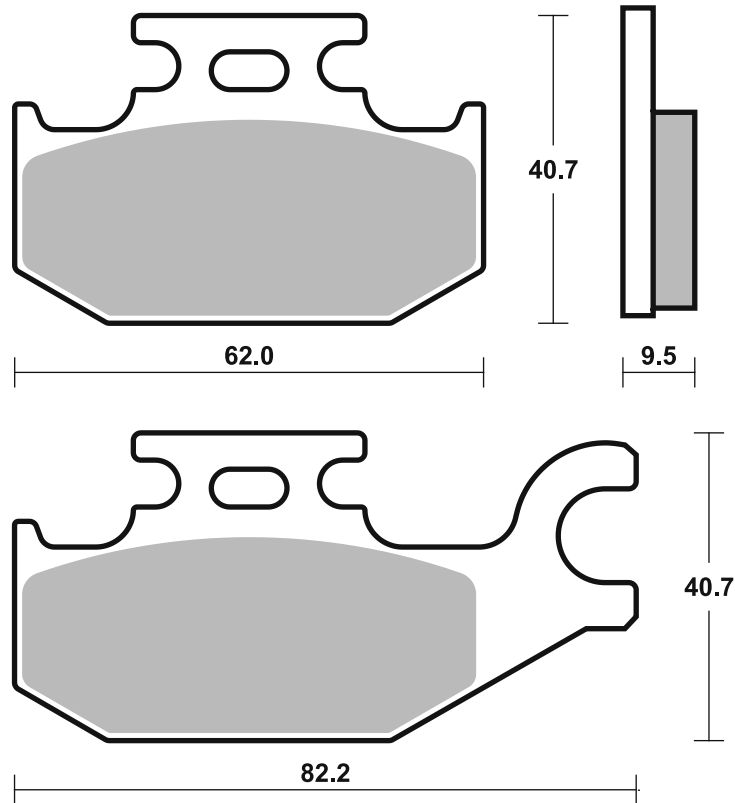

Available compounds

HF • CT • MS

SBS 197

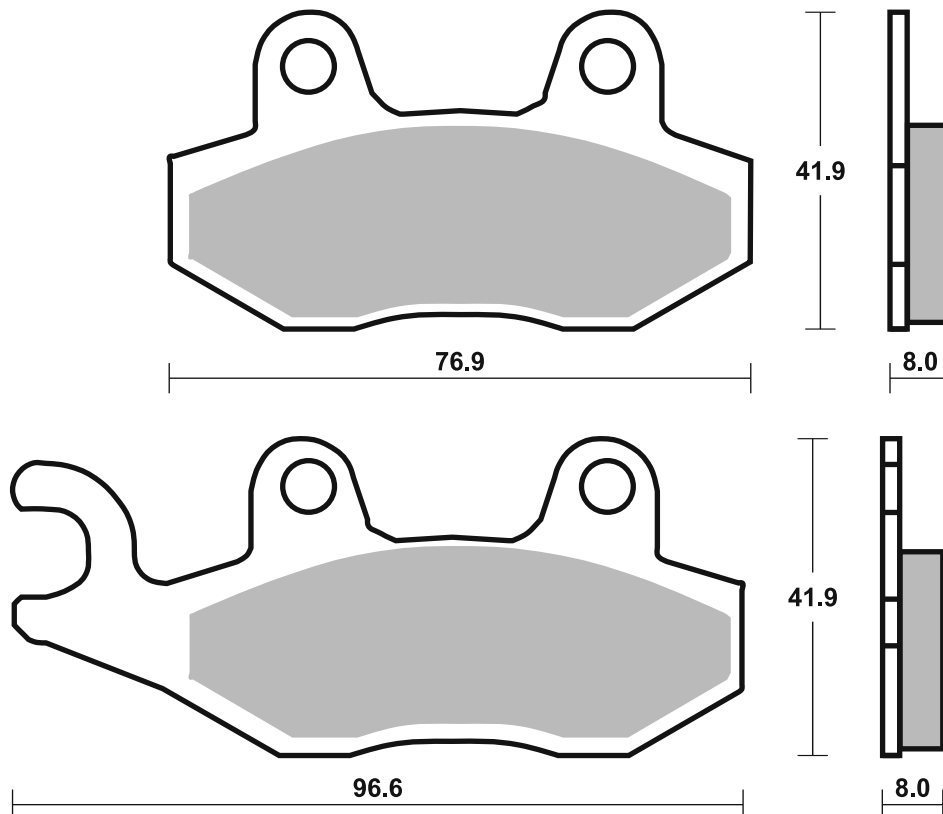

## Applications

### SBS 198

### Recommended compound



#### YAMAHA

XP	500 TMAX	08 - 11	MS
XP	500 TMAX Tech Max	11 - 11	MS
XP	530 TMAX	12 - 19	MS
XP	530 TMAX DX	17 - 19	MS
XP	530 TMAX Iron Max	15 - 19	MS
XP	530 TMAX SX	17 - 19	MS
	560 TMAX	20 - 20	MS
	560 TMAX Tech Max	20 - 20	MS

### SBS 199

### Recommended compound



#### BETA

RR	50 Enduro	10 - 18	HF
RR	50 Supermotard	08 - 13	HF

### SBS 200

### Recommended compound



#### GARELLI

	Xo Electric	12 - 12	HF
	125 Flexi	12 - 12	HF
	125 Xo	12 - 12	CT
	150 Xo	12 - 12	CT

#### ITALJET

	50 Rollercraft	08 - 12	HF
	125 Torpedo	08 - 11	CT
	150 Torpedo	08 - 12	CT

#### KEEWAY

RY8	50	10 - 16	HF
-----	----	---------	----

#### KYMCO

	50 Nexxon	08 - 12	HF	HF
	125 Nexxon	08 - 12	CT	CT



#### KYMCO

	150 Straight	08 - 11	CT	CT
--	--------------	---------	----	----

#### PEUGEOT

	50 Speedfight 3 (AC)	10 - 16	HF
	50 Speedfight 3 (LC)	10 - 16	HF
	50 Speedfight 3 RS (LC)	10 - 16	HF
	50 Speedfight 4 (AC)	15 - 16	HF
	50 Speedfight 4 (LC)	15 - 16	HF

#### SACHS

	50 MadAss	04 - 05	HF
	50 MadAss 4T	05 - 09	HF
	125 MadAss	09 - 09	HF



STREET  
AMERICAN  
SCOOTER

HF • HS • LS  
H.HF • H.CT • H.HS • H.LS  
HF • CT • MS

RACING  
OFF ROAD  
ATV

RST • DC • DCC • DS-1 • DS-2 • RQ  
SI • RSI • CS  
ATS • SI • RSI • PSI

Drawings 1:1

Available compounds

HF • CT • MS

SBS 198

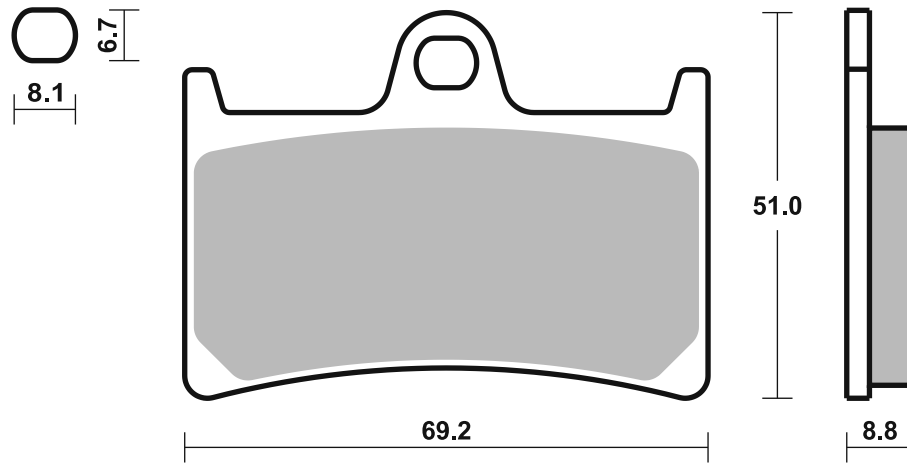

Available compounds

HF • CT

SBS 199

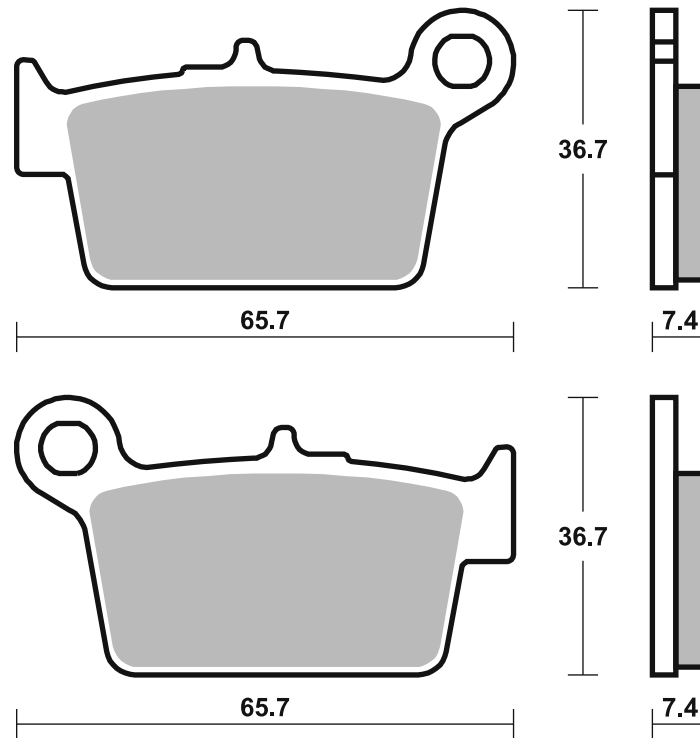

Available compounds

HF • CT

SBS 200

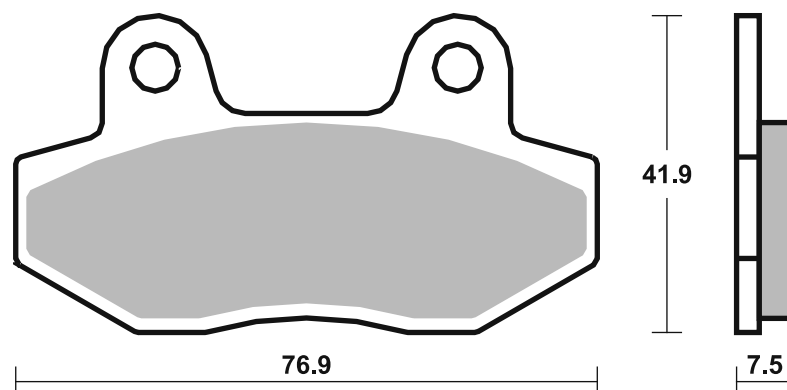

## SBS 201

## Recommended compound



<b>DAELIM</b>			
S	125 from VIN SDC007441	17 - 19	<b>CT</b>
S	300	17 - 19	<b>MS</b>
<b>PEUGEOT</b>			
LXR	125	10 - 13	<b>CT</b>
LXR	200	10 - 11	<b>CT</b>
<b>SYM</b>			
	125 Joymax Sport	16 - 16	<b>CT</b>
	125 Joyride	07 - 09	<b>CT</b>
	125 Joyride Evo	10 - 12	<b>CT</b>
	125 Joyride S	16 - 17	<b>CT</b>
HD	125 Evo DT	10 - 10	<b>CT</b>
HD2	125 Evo	14 - 14	<b>CT</b>
	200 Joyride S	16 - 17	<b>CT</b>
HD	200 Evo	07 - 13	<b>CT</b>
HD2	200 Evo	14 - 14	<b>CT</b>
	250 GTS	07 - 11	<b>MS</b>
	250 Joymax	07 - 10	<b>MS</b>
	250 Joymax Sport	16 - 17	<b>MS</b>
RV	250 Efi	10 - 10	<b>MS</b>
	300 Cruisym	17 - 17	<b>MS</b>
	300 Joymax Evo	10 - 12	<b>MS</b>
	300 Joymax Sport	16 - 17	<b>MS</b>
	300 Joyride Evo i	10 - 10	<b>MS</b>



<b>SYM</b>			
GTS	300	09 - 13	<b>MS</b>
GTS	300 Evo i	11 - 15	<b>MS</b>
<b>TGB</b>			
	125 X-Large	11 - 11	<b>CT</b>
	125 X-Motion	08 - 12	<b>CT</b>
	250 X-Motion	08 - 09	<b>CT</b>
	300 X-Motion	10 - 12	<b>CT</b>

## SBS 202

## Recommended compound



<b>GILERA</b>			
	50 Runner PJ	06 - 11	<b>HF</b>
	50 Runner SP	06 - 12	<b>HF</b>
	50 Runner SP, Purejet	98 - 05	<b>HF</b>
	50 Stalker	97 - 01	<b>HF</b>
DT	50 Stalker	01 - 05	<b>HF</b>
FX	125 Runner		
	(Grimeca cal.)	00 - 05	<b>CT</b>
FX	125 Runner (		
	Hengtong cal.)	00 - 05	<b>CT</b>
FX	125 Runner SP		
	(Grimeca cal.)	00 - 03	<b>CT</b>
FX	125 Runner SP		
	(Hengtong cal.)	00 - 03	<b>CT</b>
ST	125 Runner	12 - 13	<b>CT</b>
FXR	180 Runner		
	(Grimeca cal.)	00 - 03	<b>CT</b>
FXR	180 Runner		
	(Hengtong cal.)	00 - 03	<b>CT</b>
FXR	180 Runner SP		
	(Grimeca cal.)	00 - 00	<b>CT</b>
FXR	180 Runner SP		
	(Hengtong cal.)	00 - 00	<b>CT</b>
	200 Stalker	97 - 01	<b>CT</b>
FX	200 Runner SP	98 - 01	<b>CT</b>
RC	500 Fuoco ie	08 - 17	<b>MS</b>
<b>LAMBRETTA</b>			
V	125 Special	21 - 23	<b>CT</b>
V	125 Special Flex	21 - 23	<b>CT</b>
V	200 Special	21 - 23	<b>CT</b>
V	200 Special Flex	21 - 23	<b>CT</b>
<b>PEUGEOT</b>			
	50 Tweet Evo RS	14 - 17	<b>HF</b>
	50 Tweet RS	10 - 13	<b>HF</b>
	125 Tweet Evo	14 - 17	<b>HF</b>
	125 Tweet Evo RS	14 - 16	<b>HF</b>



<b>PEUGEOT</b>			
	125 Tweet RS	10 - 13	<b>CT</b>
	150 Tweet RS	10 - 13	<b>CT</b>
<b>PIAGGIO VESPA</b>			
	50 Liberty	97 - 14	<b>HF</b>
	50 Liberty 4T	00 - 12	<b>HF</b>
	50 Zip Disco	96 - 99	<b>HF</b>
	50 Zip Fast Rider	96 - 97	<b>HF</b>
	50 Zip RST	98 - 99	<b>HF</b>
	50 Zip Sport Production	96 - 99	<b>HF</b>
ET2	50	97 - 06	<b>HF</b>
ET4	50	00 - 05	<b>HF</b>
LX	50 2T/4T	05 - 12	<b>HF</b>
S	50 2T	07 - 14	<b>HF</b>
S	50 4T	09 - 14	<b>HF</b>
	125 MP3	06 - 07	<b>CT</b>
	125 MP3 Efi	08 - 11	<b>CT</b>
	125 MP3 Hybrid	09 - 12	<b>CT</b>
	125 MP3 Yourban	11 - 12	<b>CT</b>
	125 Sfera	95 - 01	<b>CT</b>
	125 Zip II 4T	00 - 08	<b>CT</b>
ET4	125	96 - 10	<b>CT</b>
LE	125 Liberty	99 - 03	<b>CT</b>
LX	125 4T	05 - 13	<b>CT</b>
PX	125 70	16 - 16	<b>CT</b>
S	125 4T	07 - 10	<b>CT</b>
	150 Liberty	99 - 03	<b>CT</b>
ET4	150	02 - 06	<b>CT</b>
PX	150	02 - 06	<b>CT</b>
	200 Liberty	06 - 13	<b>CT</b>
PX	200	02 - 07	<b>CT</b>
	250 LX 60	06 - 10	<b>MS</b>
	250 MP3	06 - 07	<b>MS</b>
	250 MP3 Efi	08 - 09	<b>MS</b>
	250 MP3 LT iE	09 - 09	<b>MS</b>
	300 MP3 Hybrid	11 - 12	<b>MS</b>
	300 MP3 Hybrid iE	11 - 19	<b>MS</b>



<b>PIAGGIO VESPA</b>			
	300 MP3 iE	10 - 19	<b>MS</b>
	300 MP3 LT	13 - 19	<b>MS</b>
	300 MP3 LT Business	13 - 19	<b>MS</b>
	300 MP3 LT Touring	11 - 12	<b>MS</b>
	300 MP3 Touring	11 - 12	<b>MS</b>
	300 MP3 Yourban iE	11 - 19	<b>MS</b>
	400 MP3 iE	07 - 10	<b>MS</b>
	400 MP3 LT iE	09 - 10	<b>MS</b>
	400 MP3 LT Touring	11 - 12	<b>MS</b>
	400 MP3 Touring	11 - 12	<b>MS</b>
	500 MP3	10 - 10	<b>MS</b>
	500 MP3 LT Touring		
	Business	11 - 13	<b>MS</b>
	500 MP3 LT Touring		
	Sport	11 - 13	<b>MS</b>
	500 MP3 Touring		
	Business	11 - 12	<b>MS</b>
	500 MP3 Touring Sport	11 - 12	<b>MS</b>
<b>SYM</b>			
	50 Fiddle III	16 - 19	<b>CT</b>
	125 Fiddle III	16 - 19	<b>CT</b>
	125 Jet 14	17 - 19	<b>CT</b>
	125 Jet X	24 - 24	<b>CT</b>
	125 Symphony S	11 - 17	<b>CT</b>
	125 Symphony SR	11 - 17	<b>CT</b>
	125 Symphony ST	15 - 19	<b>CT</b>
	150 Symphony S	11 - 15	<b>CT</b>
	150 Symphony SR	11 - 15	<b>CT</b>
	200 Fiddle III	16 - 19	<b>CT</b>

STREET  
AMERICAN  
SCOOTER

HF • HS • LS  
H.HF • H.CT • H.HS • H.LS  
HF • CT • MS

RACING  
OFF ROAD  
ATV

RST • DC • DCC • DS-1 • DS-2 • RQ  
SI • RSI • CS  
ATS • SI • RSI • PSI

Drawings 1:1

Available compounds

HF • CT • MS

SBS 201

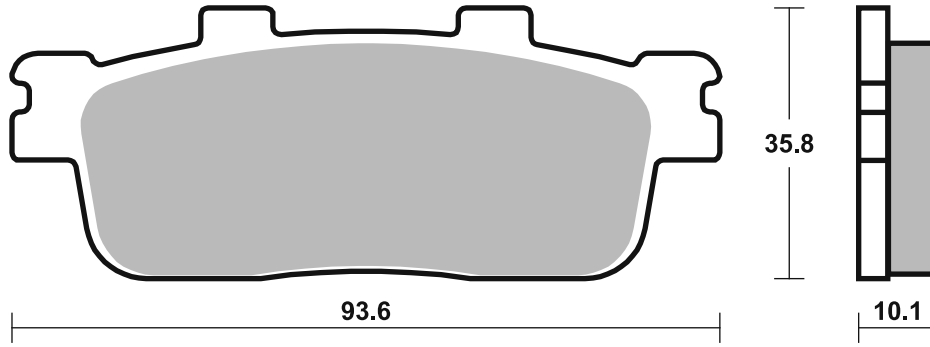

Available compounds

HF • CT • MS

SBS 202

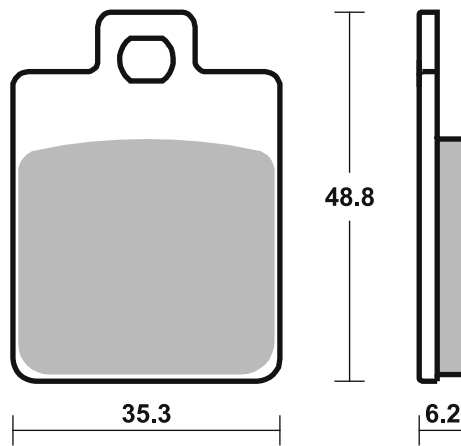



STREET  
AMERICAN  
SCOOTER

HF • HS • LS  
H.HF • H.CT • H.HS • H.LS  
HF • CT • MS

RACING  
OFF ROAD  
ATV

RST • DC • DCC • DS-1 • DS-2 • RQ  
SI • RSI • CS  
ATS • SI • RSI • PSI

Available compounds

HF • CT

SBS 203

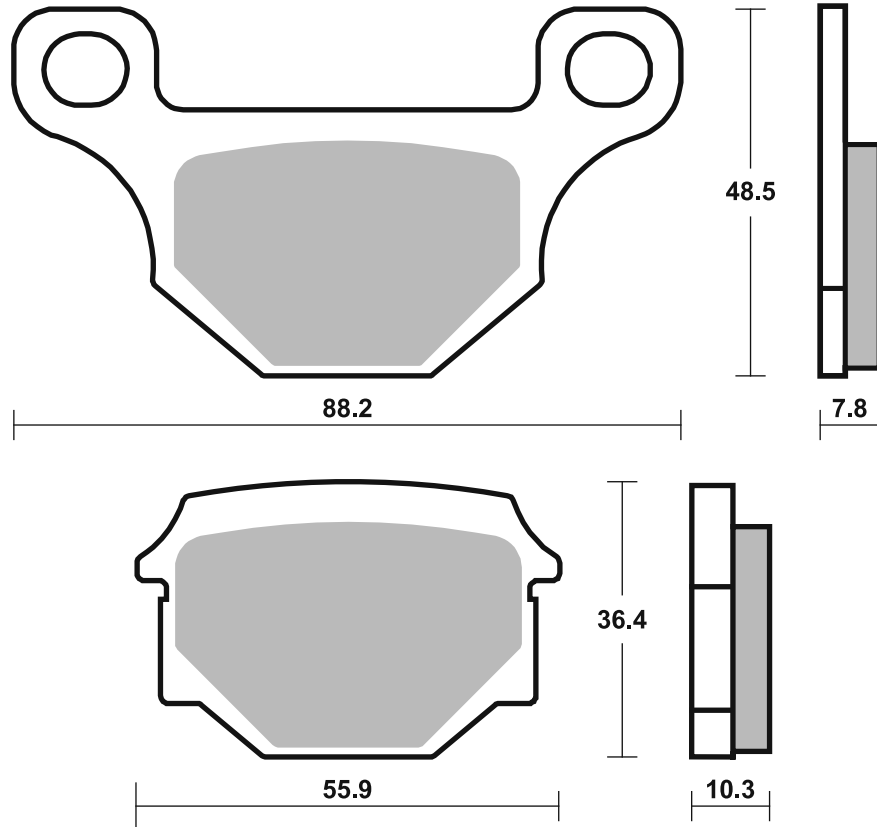

Available compounds

HF • CT • MS

SBS 204

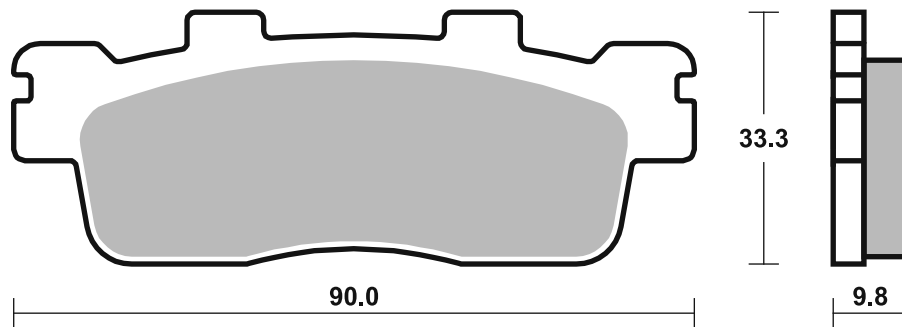



STREET  
AMERICAN  
SCOOTER

HF • HS • LS  
H.HF • H.CT • H.HS • H.LS  
HF • CT • MS

RACING  
OFF ROAD  
ATV

RST • DC • DCC • DS-1 • DS-2 • RQ  
SI • RSI • CS  
ATS • SI • RSI • PSI

Drawings 1:1

Available compounds

HF • CT • MS

SBS 205

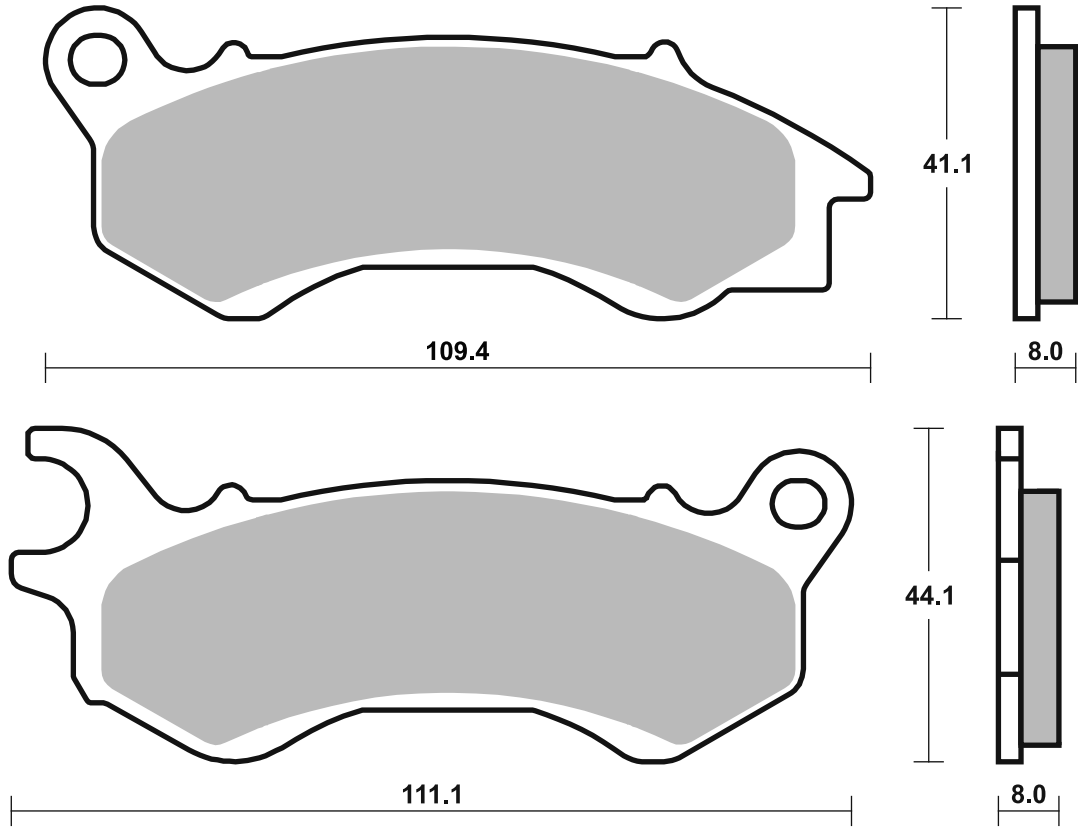

Available compounds

HF • CT

SBS 206

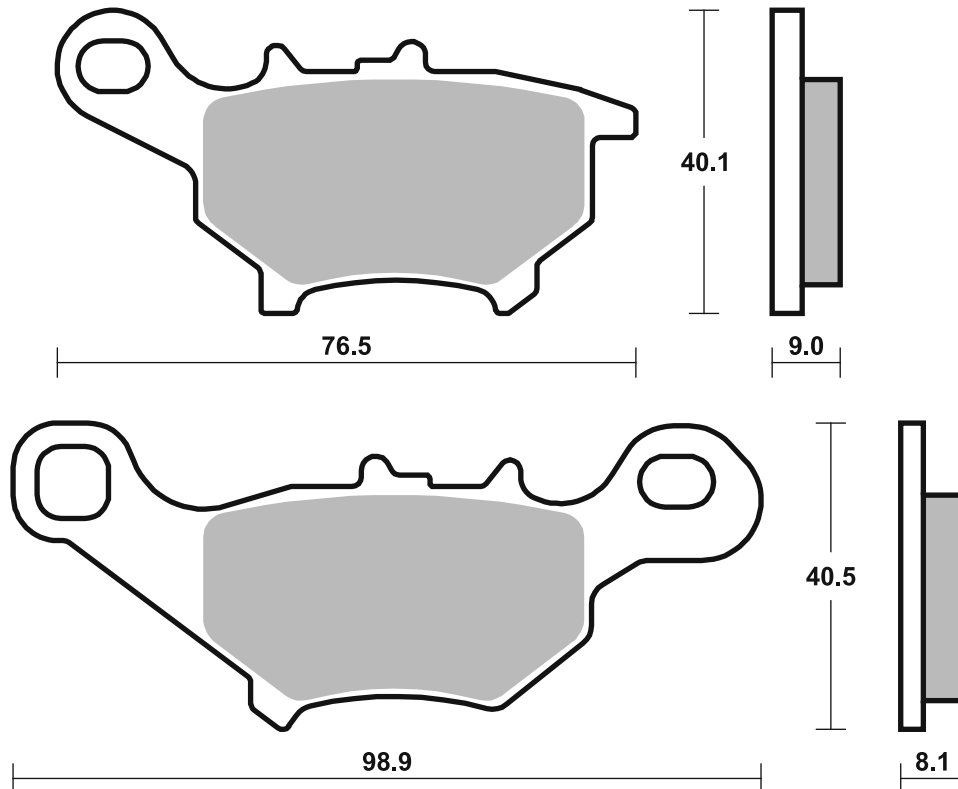



Applications

**SBS 207 Recommended compound**



<b>YAMAHA</b>			
NXC	125 Cygnus	10 - 11	CT

**SBS 208 Recommended compound**



<b>MBK</b>			
YW	125 Z	10 - 10	CT
<b>YAMAHA</b>			
	125 Xenter	12 - 18	CT
BWs	125	10 - 11	CT
YW	125 Z	10 - 11	CT
	150 Xenter	12 - 18	CT

STREET  
AMERICAN  
SCOOTER

HF • HS • LS  
H.HF • H.CT • H.HS • H.LS  
HF • CT • MS

RACING  
OFF ROAD  
ATV

RST • DC • DCC • DS-1 • DS-2 • RQ  
SI • RSI • CS  
ATS • SI • RSI • PSI

Drawings 1:1

Available compounds

HF • CT

SBS 207

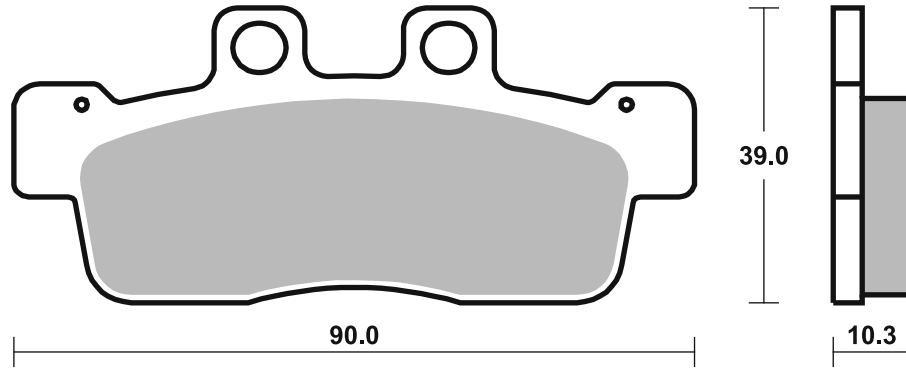

Available compounds

HF • CT

SBS 208

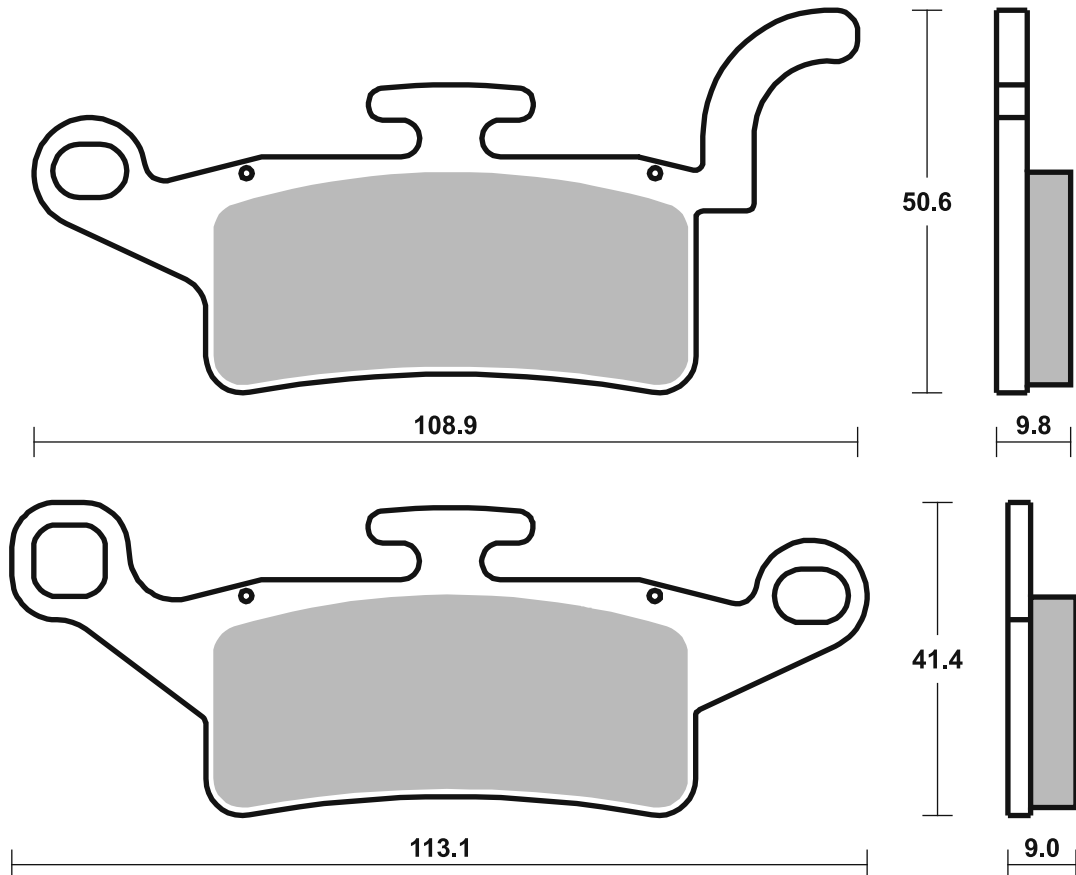

Dimensions in mm / Dimensions en mm  
1" = 25.4 mm, 1 mm = 0.04"

Brake Pad 1:1 Drawings,  
Compounds, Fitments

## Applications

### SBS 209

### Recommended compound



<b>APRILIA</b>			
SRV	850 (Parking Brake)	12 - 19	<b>HF</b>

<b>BMW</b>			
C	Evolution (Parking Brake)	12 - 18	<b>HF</b>
C	600 Sport (Parking Brake)	12 - 15	<b>HF</b>
C	650 GT (Parking Brake)	12 - 15	<b>HF</b>

<b>GILERA</b>			
RC	500 Fuoco ie (Parking Brake)	08 - 17	<b>HF</b>
GP	800 (Parking Brake)	08 - 15	<b>HF</b>

<b>HONDA</b>			
FJS	400 Silverwing (Parking Brake)	06 - 08	<b>HF</b>
FJS	600 Silverwing (Parking Brake)	01 - 18	<b>HF</b>
DN-01	680 (Parking Brake)	08 - 11	<b>HF</b>
ADV	750 X-ADV (Parking Brake)	17 - 24	<b>HF</b>
NC	750 D Integra w/DCT (Parking Brake)	14 - 19	<b>HF</b>

<b>PIAGGIO VESPA</b>			
	125 MP3 (Parking Brake)	06 - 07	<b>HF</b>
	125 MP3 Efi (Parking Brake)	08 - 11	<b>HF</b>
	125 MP3 Hybrid (Parking Brake)	09 - 12	<b>HF</b>



<b>PIAGGIO VESPA</b>			
	125 MP3 Yourban (Parking Brake)	11 - 12	<b>HF</b>
	250 MP3 (Parking Brake)	06 - 07	<b>HF</b>
	250 MP3 Efi (Parking Brake)	08 - 09	<b>HF</b>
	250 MP3 LT iE (Parking Brake)	09 - 09	<b>HF</b>
	300 MP3 Hybrid (Parking Brake)	11 - 12	<b>HF</b>
	300 MP3 Hybrid iE (Parking Brake)	11 - 19	<b>HF</b>
	300 MP3 iE (Parking Brake)	10 - 19	<b>HF</b>
	300 MP3 LT (Parking Brake)	13 - 19	<b>HF</b>
	300 MP3 LT Business (Parking Brake)	13 - 19	<b>HF</b>
	300 MP3 LT iE ABS (Parking Brake)	14 - 19	<b>HF</b>
	300 MP3 LT Sport ABS (Parking Brake)	14 - 19	<b>HF</b>
	300 MP3 LT Touring (Parking Brake)	11 - 12	<b>HF</b>
	300 MP3 Touring (Parking Brake)	11 - 12	<b>HF</b>
	300 MP3 Yourban iE (Parking Brake)	11 - 19	<b>HF</b>
	350 X10 Executive (Parking Brake)	13 - 16	<b>HF</b>
	400 MP3 iE (Parking Brake)	07 - 10	<b>HF</b>



<b>PIAGGIO VESPA</b>			
	400 MP3 LT iE (Parking Brake)	09 - 10	<b>HF</b>
	400 MP3 LT Touring (Parking Brake)	11 - 12	<b>HF</b>
	400 MP3 Touring (Parking Brake)	11 - 12	<b>HF</b>
	500 MP3 (Parking Brake)	10 - 10	<b>HF</b>
	500 MP3 LT Touring Business (Parking Brake)	11 - 13	<b>HF</b>
	500 MP3 LT Touring Business ABS (Parking Brake)	14 - 15	<b>HF</b>
	500 MP3 LT Touring Sport (Parking Brake)	11 - 13	<b>HF</b>
	500 MP3 LT Touring Sport ABS (Parking Brake)	14 - 15	<b>HF</b>
	500 MP3 Touring Business (Parking Brake)	11 - 12	<b>HF</b>
	500 MP3 Touring Sport (Parking Brake)	11 - 12	<b>HF</b>
	500 X10 Executive (Parking Brake)	13 - 15	<b>HF</b>

### SBS 210

### Recommended compound



<b>TGB</b>			
	125 X-Large	11 - 11	<b>CT</b>
	125 X-Motion	08 - 12	<b>CT</b>
	250 X-Motion	08 - 09	<b>MS</b>
	300 X-Motion	10 - 12	<b>MS</b>

STREET  
AMERICAN  
SCOOTER

HF • HS • LS  
H.HF • H.CT • H.HS • H.LS  
HF • CT • MS

RACING  
OFF ROAD  
ATV

RST • DC • DCC • DS-1 • DS-2 • RQ  
SI • RSI • CS  
ATS • SI • RSI • PSI

Drawings 1:1

Available compounds

HF

SBS 209

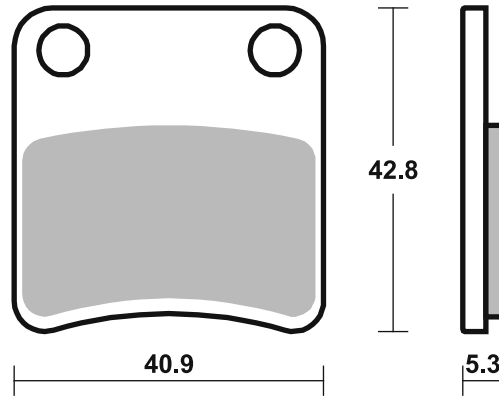

Available compounds

HF • CT • MS

SBS 210

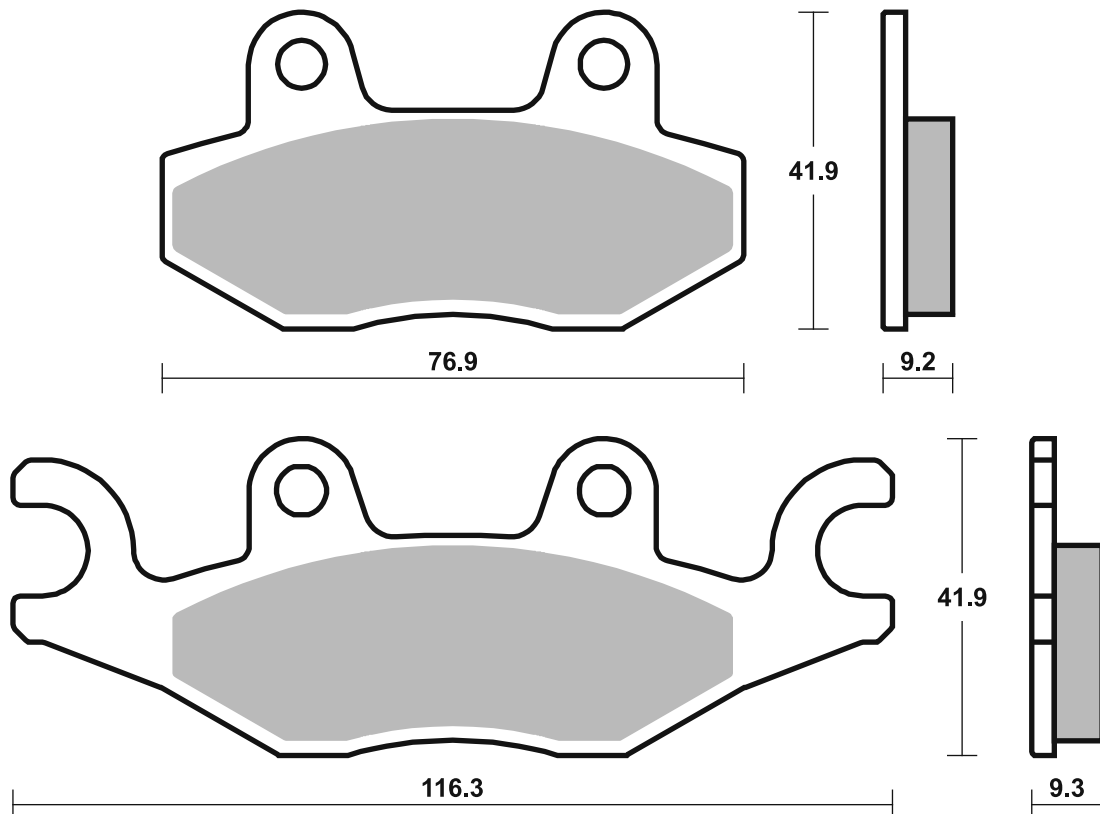

Applications

SBS 211

Recommended compound



<b>ELSTARS</b>			
	125 Blade S	10 - 11	HF HF
<b>GENERIC</b>			
SM	50 Mini Trigger	08 - 09	HF HF
X	50 Mini Trigger	08 - 09	HF HF
<b>ITALJET</b>			
	50 Pit Jet	07 - 09	HF HF
	125 Pit Jet	07 - 09	HF HF
<b>LAMBRETTA</b>			
	50 Pato	08 - 09	HF
<b>LIFAN</b>			
LF	125 Off Road	07 - 07	HF
<b>MOTOM</b>			
	50 Spasso	08 - 09	HF
<b>QUADZILLA</b>			
WK	140	06 - 08	HF
<b>STOMP</b>			
	125 Elite	07 - 09	HF

SBS 212

Recommended compound



<b>KYMCO</b>			
	400 Xciting i	12 - 14	MS
S	400 Xciting i TCS	22 - 23	CT
	500 Xciting	04 - 15	MS
	500 Xciting i Evo ABS	11 - 13	MS
	500 Xciting R ABS	09 - 13	MS
	700 MyRoad, ABS	09 - 15	MS

Brake Pad 1:1 Drawings, Compounds, Fitments

STREET  
AMERICAN  
SCOOTER

HF • HS • LS  
H.HF • H.CT • H.HS • H.LS  
HF • CT • MS

RACING  
OFF ROAD  
ATV

RST • DC • DCC • DS-1 • DS-2 • RQ  
SI • RSI • CS  
ATS • SI • RSI • PSI

Available compounds

HF • CT

SBS 211

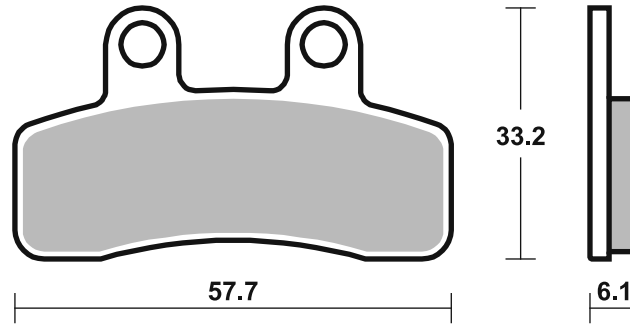

Available compounds

HF • CT • MS

SBS 212

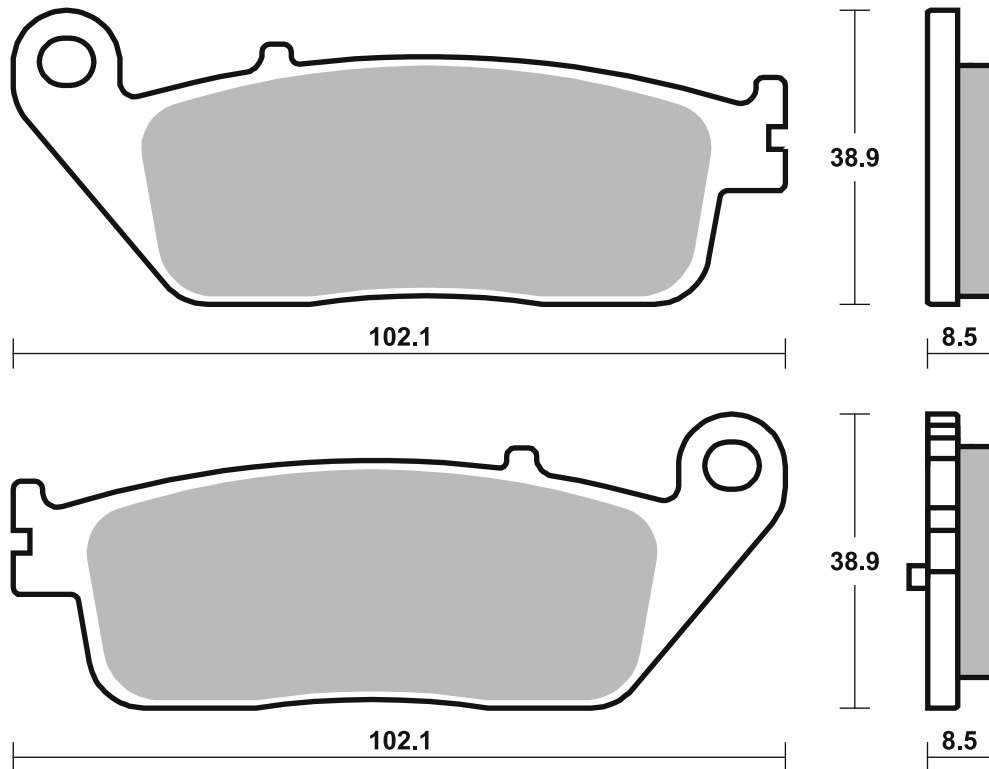

# Applications

## SBS 213 Recommended compound



<b>LIFAN</b>			
LF	125 Off Road	07 - 07	HF
<b>QUADZILLA</b>			
WK	140	06 - 08	HF
<b>STOMP</b>			
	125 Elite	07 - 09	HF

## SBS 214 Recommended compound



<b>KYMCO</b>			
	400 Xciting i	12 - 14	MS
S	400 Xciting i TCS	22 - 23	MS
<b>PEUGEOT</b>			
XP	400	23 - 23	MS

## SBS 215 Recommended compound



<b>AEON</b>			
	400 Elite	14 - 15	MS
<b>SYM</b>			
	300 Cruisym	17 - 17	MS
	400 i Maxsym	11 - 17	MS
	400 Maxsym GT	24 - 24	MS
	465 Maxsym TL	20 - 20	MS
TL	508 Maxsym TCS	22 - 22	MS
	600 i Maxsym	14 - 19	MS
	600 i Maxsym Sport	18 - 19	MS

Brake Pad 1:1 Drawings,  
Compounds, Fitments



STREET  
AMERICAN  
SCOOTER

HF • HS • LS  
H.HF • H.CT • H.HS • H.LS  
HF • CT • MS

RACING  
OFF ROAD  
ATV

RST • DC • DCC • DS-1 • DS-2 • RQ  
SI • RSI • CS  
ATS • SI • RSI • PSI

Drawings 1:1

Available compounds

HF • CT

SBS 213

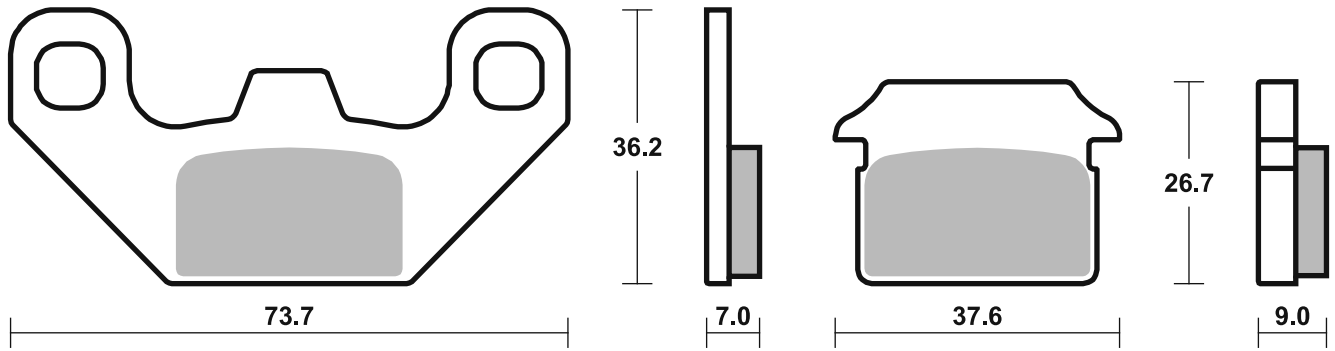

Available compounds

HF • CT • MS

SBS 214

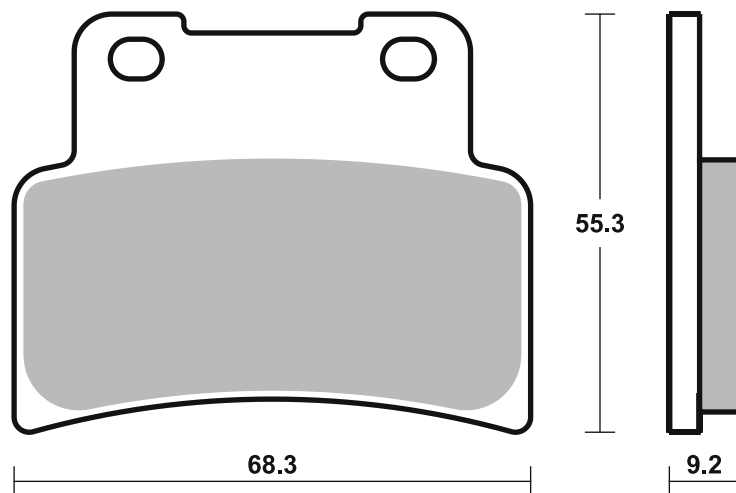

Available compounds

HF • CT • MS

SBS 215

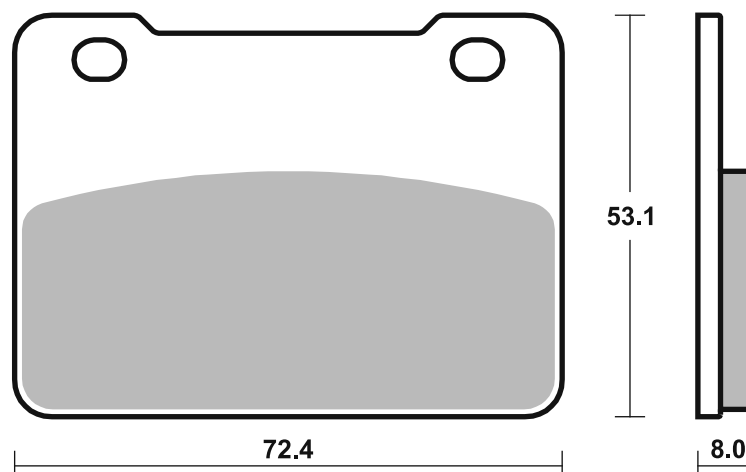



STREET  
AMERICAN  
SCOOTER

HF • HS • LS  
H.HF • H.CT • H.HS • H.LS  
HF • CT • MS

RACING  
OFF ROAD  
ATV

RST • DC • DCC • DS-1 • DS-2 • RQ  
SI • RSI • CS  
ATS • SI • RSI • PSI

Drawings 1:1

Available compounds

HF • CT

SBS 216

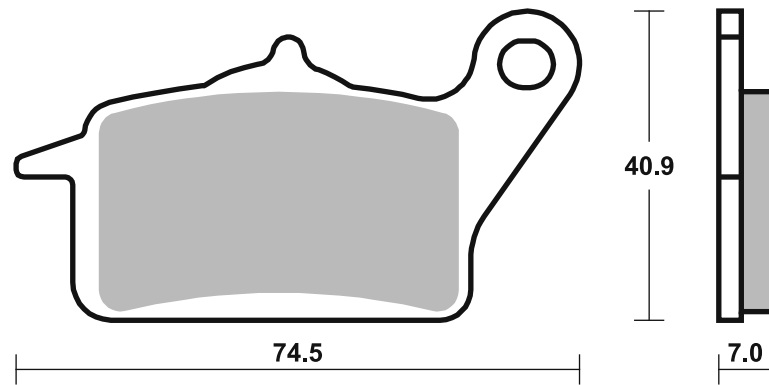
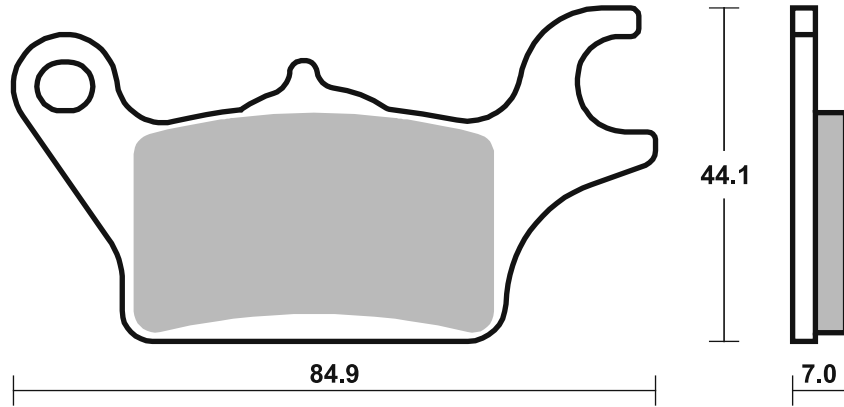

Available compounds

HF • CT

SBS 217

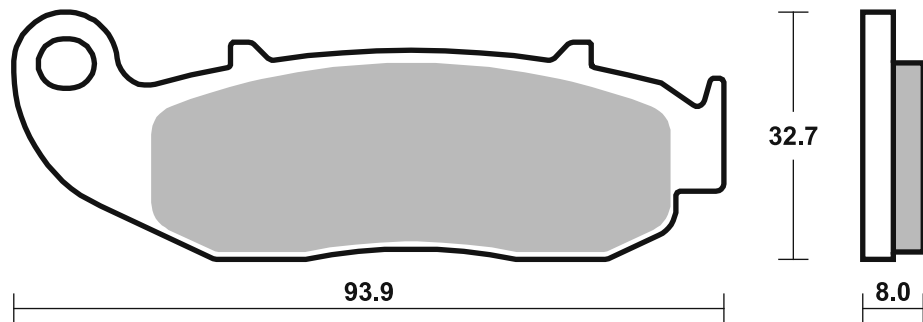
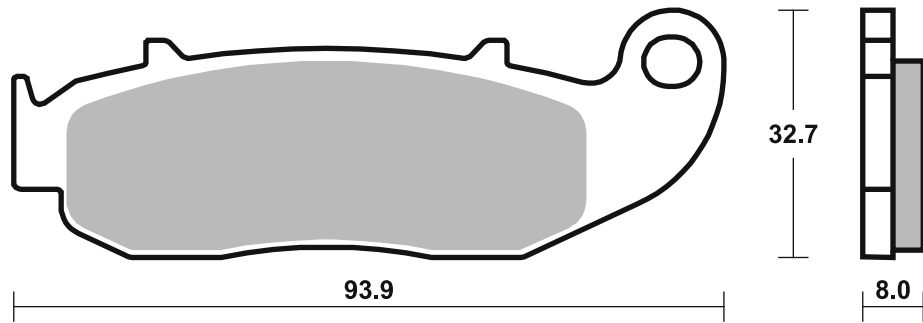

## Applications

### SBS 218 Recommended compound



<b>SYM</b>		
400 i Maxsym	11 - 17	<b>MS</b>
400 Maxsym GT	24 - 24	<b>MS</b>
465 Maxsym TL	20 - 20	<b>MS</b>
TL 508 Maxsym TCS	22 - 22	<b>MS</b>
600 i Maxsym	14 - 19	<b>MS</b>
600 i Maxsym Sport	18 - 19	<b>MS</b>

### SBS 219 Recommended compound



<b>PEUGEOT</b>			
400 Metropolis	15 - 16	<b>MS</b>	<b>MS</b>

STREET  
AMERICAN  
SCOOTER

HF • HS • LS  
H.HF • H.CT • H.HS • H.LS  
HF • CT • MS

RACING  
OFF ROAD  
ATV

RST • DC • DCC • DS-1 • DS-2 • RQ  
SI • RSI • CS  
ATS • SI • RSI • PSI

Drawings 1:1

Available compounds

HF • CT • MS

SBS 218

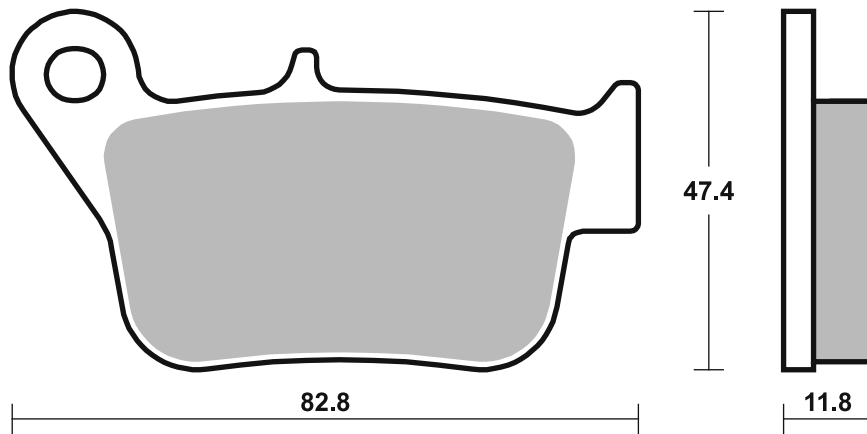
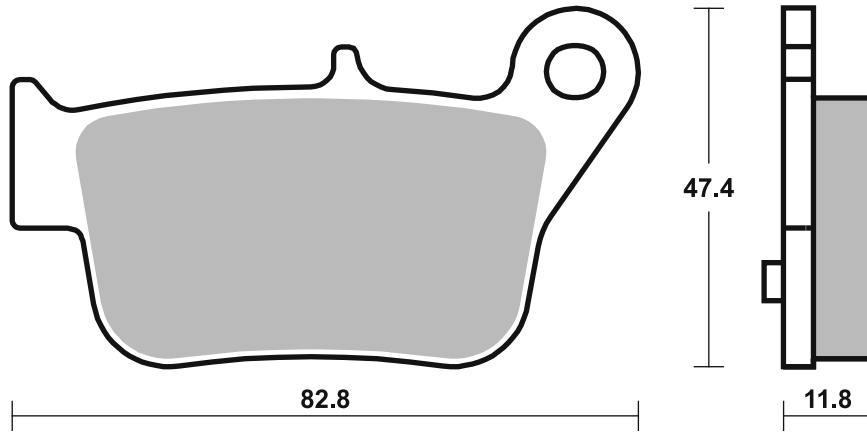

Available compounds

MS

SBS 219

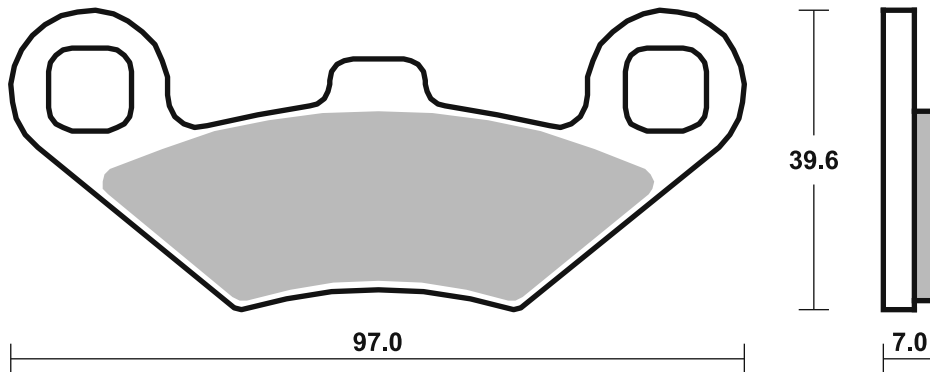



STREET  
AMERICAN  
SCOOTER

HF • HS • LS  
H.HF • H.CT • H.HS • H.LS  
HF • CT • MS

RACING  
OFF ROAD  
ATV

RST • DC • DCC • DS-1 • DS-2 • RQ  
SI • RSI • CS  
ATS • SI • RSI • PSI

Available compounds

HF • CT

SBS 220

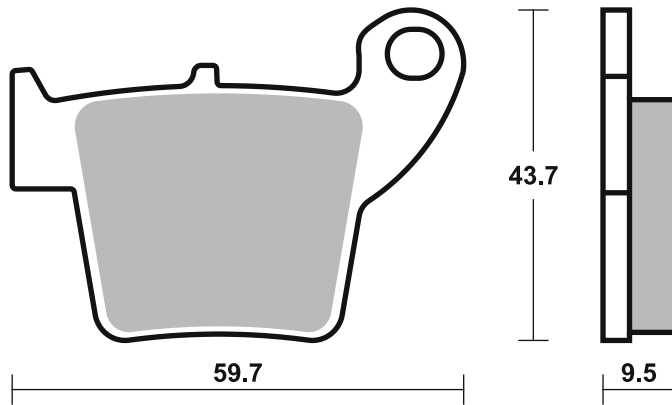
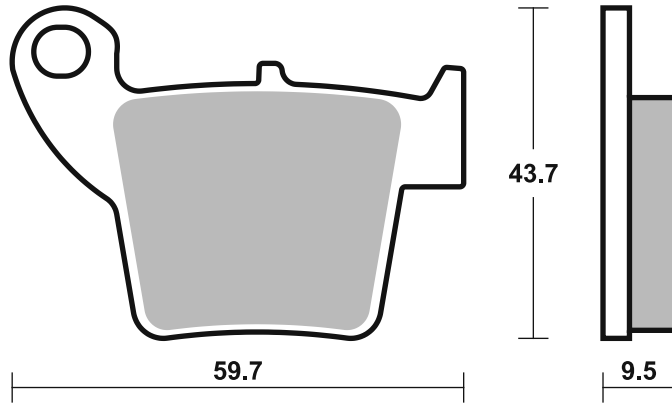

Available compounds

HF • CT • MS

SBS 221

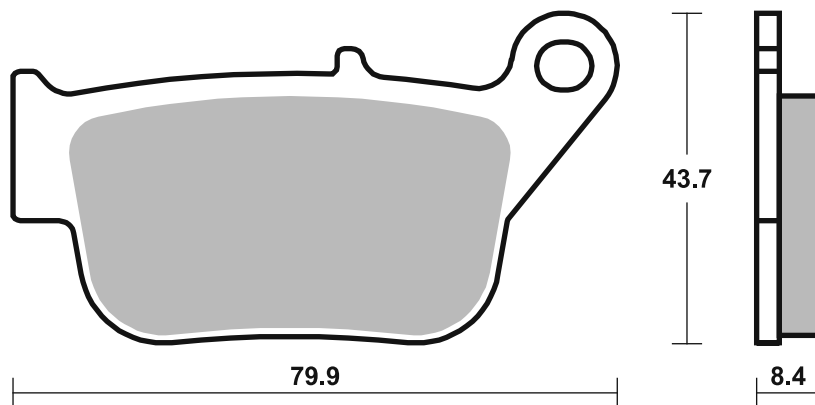
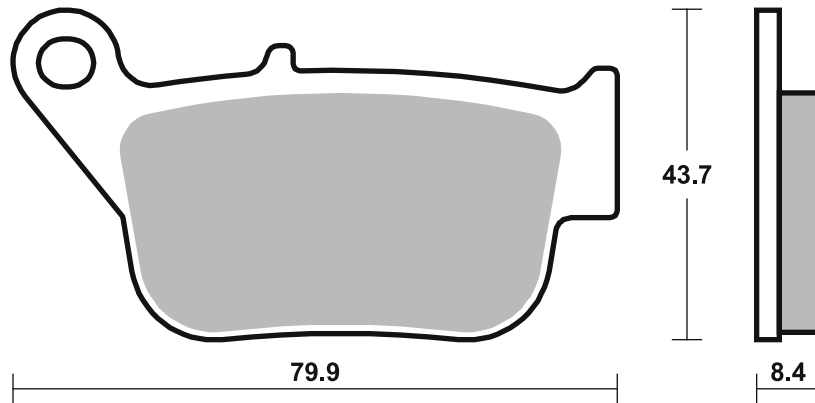

# Applications

## SBS 222 Recommended compound



YAMAHA			
MW	125 Tricity	14 - 19	<b>CT</b>
	300 Tricity	20 - 22	<b>CT</b>

## SBS 223 Recommended compound



SUZUKI			
	125 Address	23 - 24	<b>CT</b>
	125 Avensis	23 - 23	<b>CT</b>
	125 Burgman Street EX	23 - 24	<b>CT</b>

YAMAHA			
MW	125 Tricity	14 - 19	<b>CT</b>
	300 Tricity	20 - 22	<b>CT</b>



STREET  
AMERICAN  
SCOOTER

HF • HS • LS  
H.HF • H.CT • H.HS • H.LS  
HF • CT • MS

RACING  
OFF ROAD  
ATV

RST • DC • DCC • DS-1 • DS-2 • RQ  
SI • RSI • CS  
ATS • SI • RSI • PSI

Available compounds

HF • CT

SBS 222

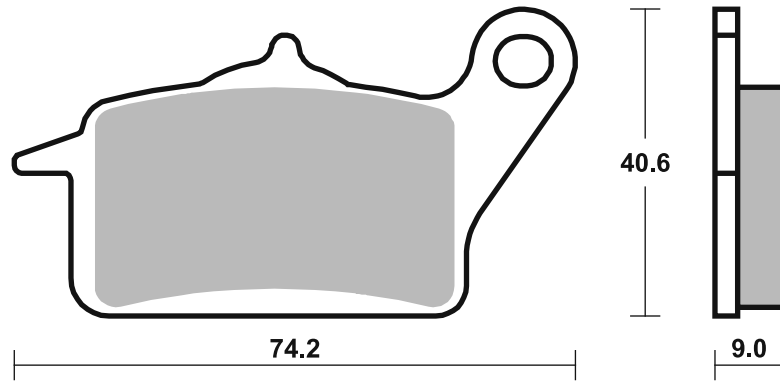
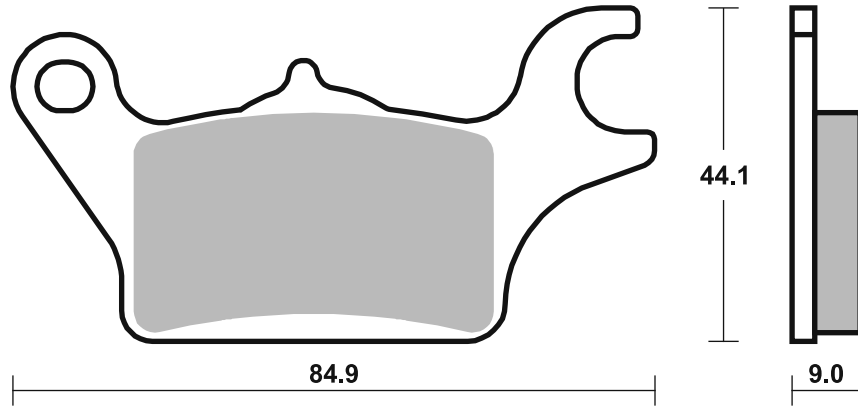

Available compounds

HF • CT

SBS 223

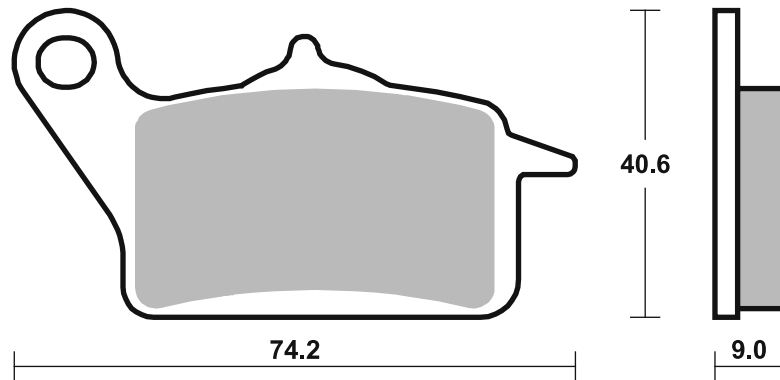
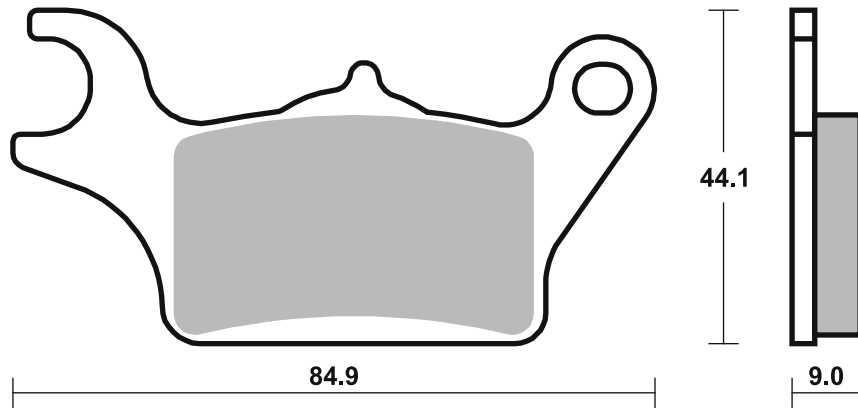



STREET  
AMERICAN  
SCOOTER

HF • HS • LS  
H.HF • H.CT • H.HS • H.LS  
HF • CT • MS

RACING  
OFF ROAD  
ATV

RST • DC • DCC • DS-1 • DS-2 • RQ  
SI • RSI • CS  
ATS • SI • RSI • PSI

Drawings 1:1

Available compounds

HF • CT • MS

SBS 224

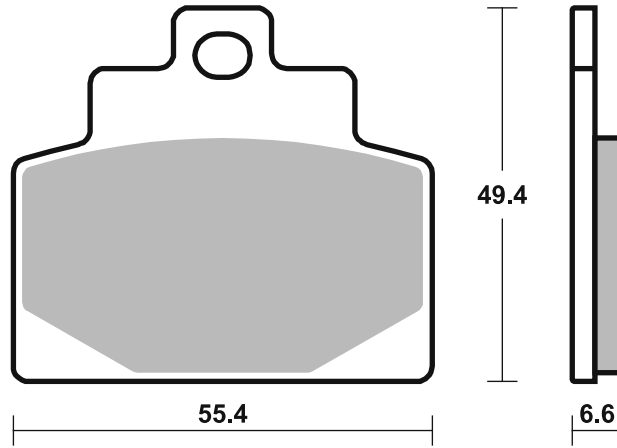

Available compounds

HF • CT

SBS 225

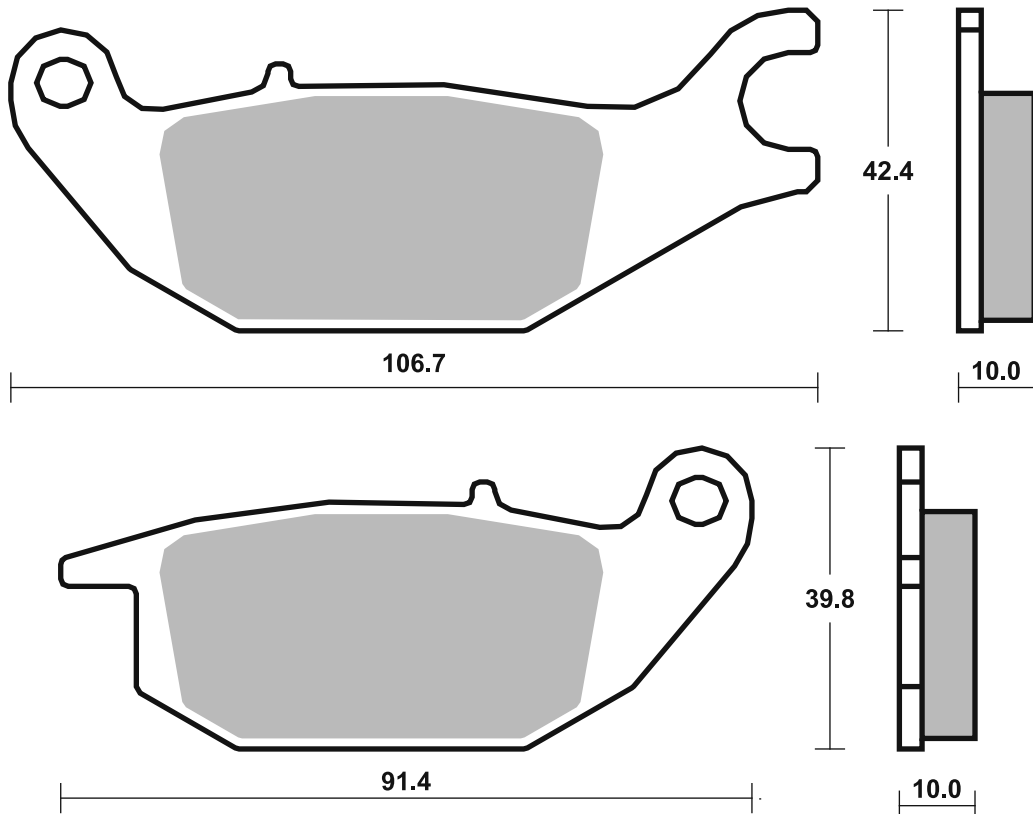



STREET  
AMERICAN  
SCOOTER

HF • HS • LS  
H.HF • H.CT • H.HS • H.LS  
HF • CT • MS

RACING  
OFF ROAD  
ATV

RST • DC • DCC • DS-1 • DS-2 • RQ  
SI • RSI • CS  
ATS • SI • RSI • PSI

Drawings 1:1

Available compounds

HF • CT

SBS 226

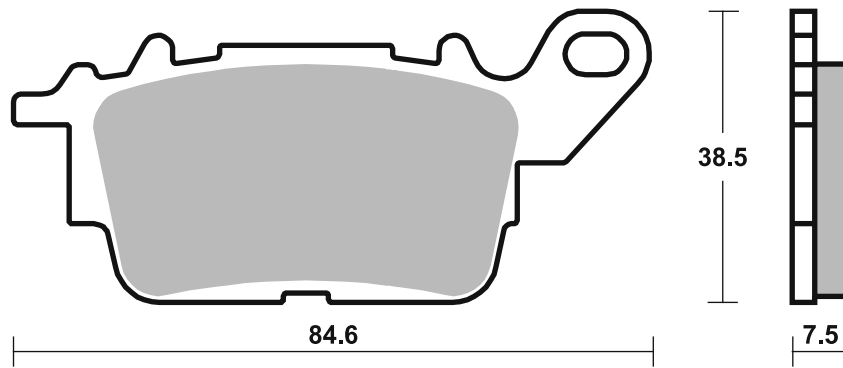
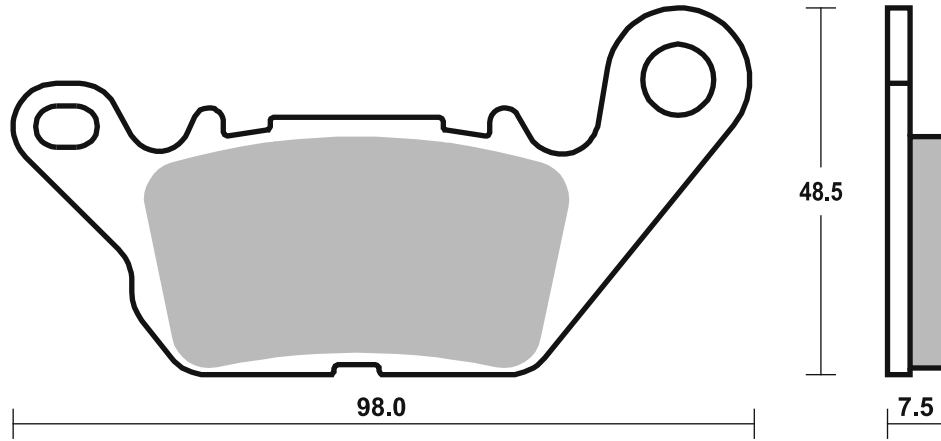

Available compounds

HF • CT

SBS 227

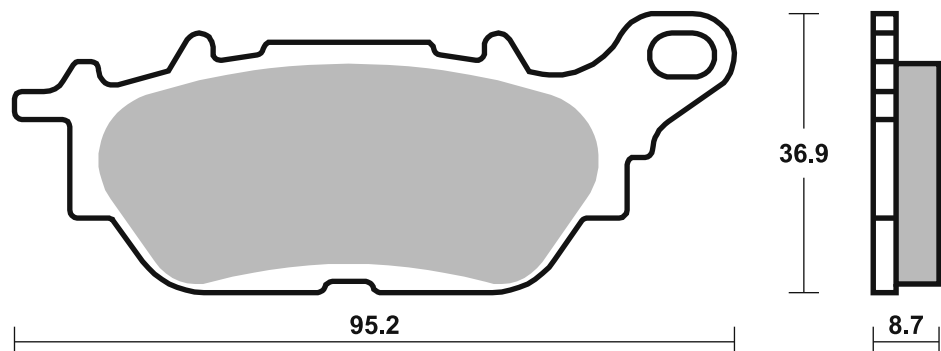
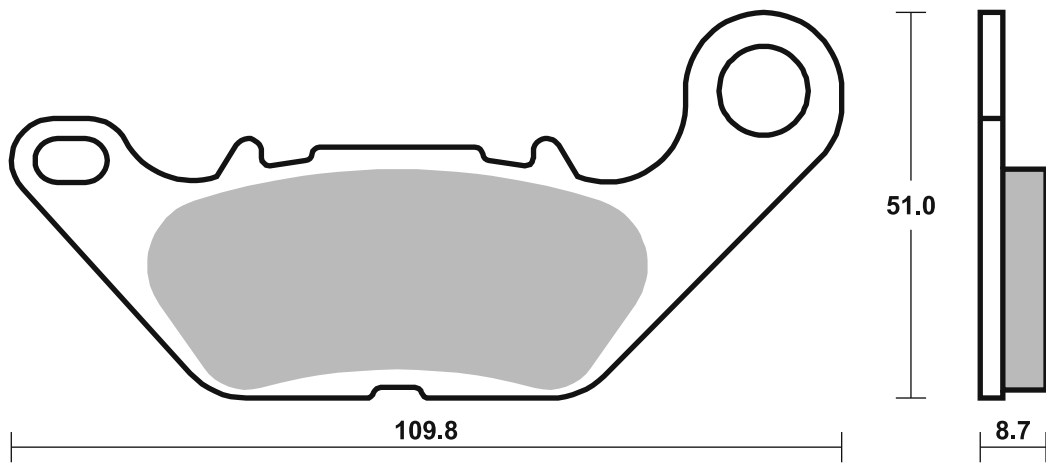

Dimensions in mm / Dimensions en mm  
1" = 25.4 mm, 1 mm = 0.04"

Brake Pad 1:1 Drawings,  
Compounds, Fitments



STREET  
AMERICAN  
SCOOTER

HF • HS • LS  
H.HF • H.CT • H.HS • H.LS  
HF • CT • MS

RACING  
OFF ROAD  
ATV

RST • DC • DCC • DS-1 • DS-2 • RQ  
SI • RSI • CS  
ATS • SI • RSI • PSI

Drawings 1:1

Available compounds

HF • CT

SBS 228

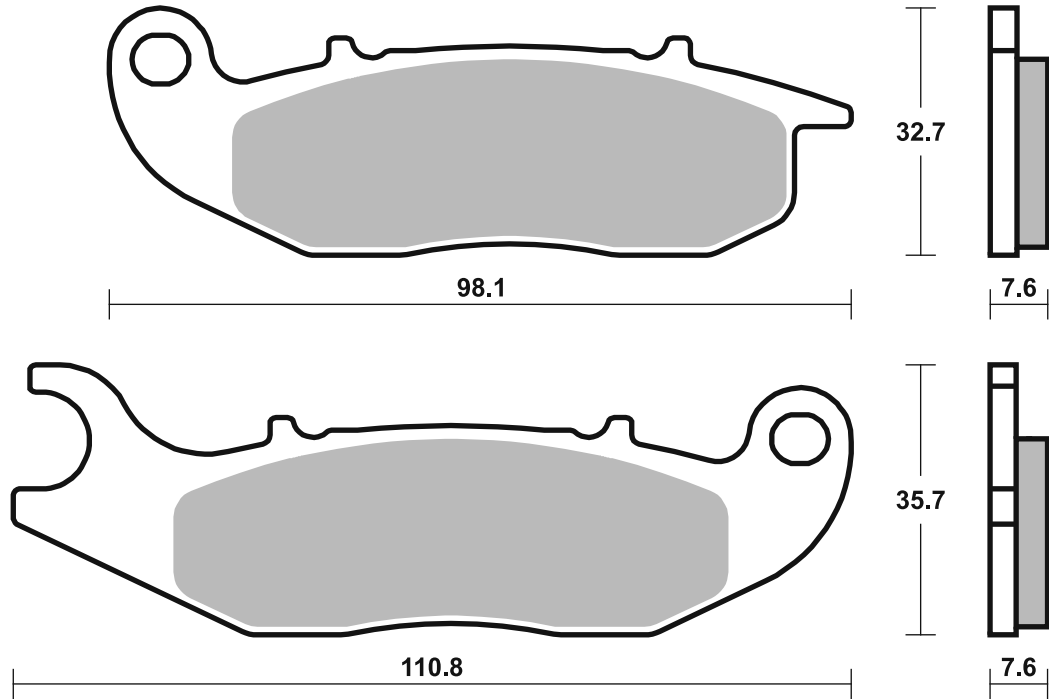

Available compounds

HF • CT

SBS 229

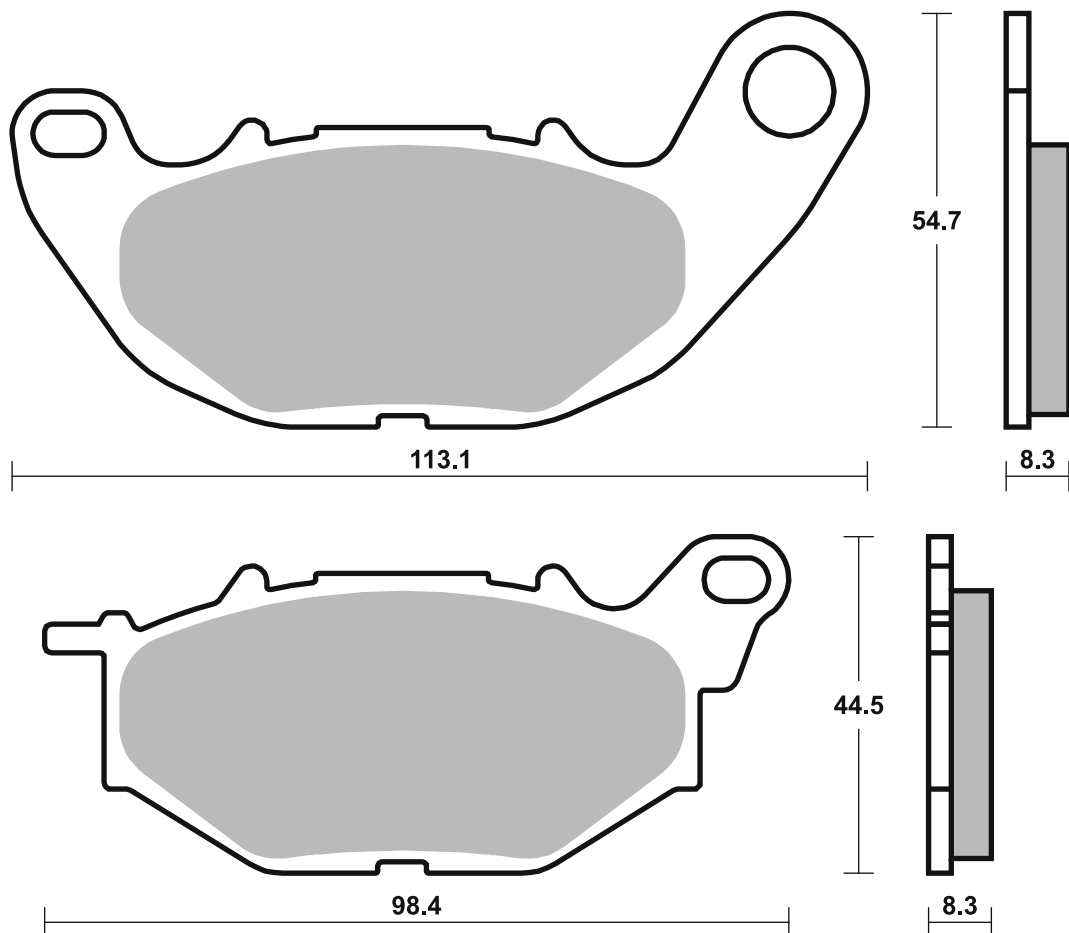

Dimensions in mm / Dimensions en mm  
1" = 25.4 mm, 1 mm = 0.04"

Brake Pad 1:1 Drawings,  
Compounds, Fitments

Applications

**SBS 230** Recommended compound



YAMAHA			
YP	125 RA XMAX ABS	17 - 19	<b>CT</b>
	300 Tricity	20 - 22	<b>CT</b>
YP	300 XMAX	17 - 23	<b>CT</b>

**SBS 231** Recommended compound



BMW			
	CE 04	21 - 24	<b>MS</b>
C	400 GT	19 - 24	<b>MS</b>
C	400 X	18 - 24	<b>MS</b>



STREET  
AMERICAN  
SCOOTER

HF • HS • LS  
H.HF • H.CT • H.HS • H.LS  
HF • CT • MS

RACING  
OFF ROAD  
ATV

RST • DC • DCC • DS-1 • DS-2 • RQ  
SI • RSI • CS  
ATS • SI • RSI • PSI

Drawings 1:1

Available compounds

**HF • CT**

**SBS 230**

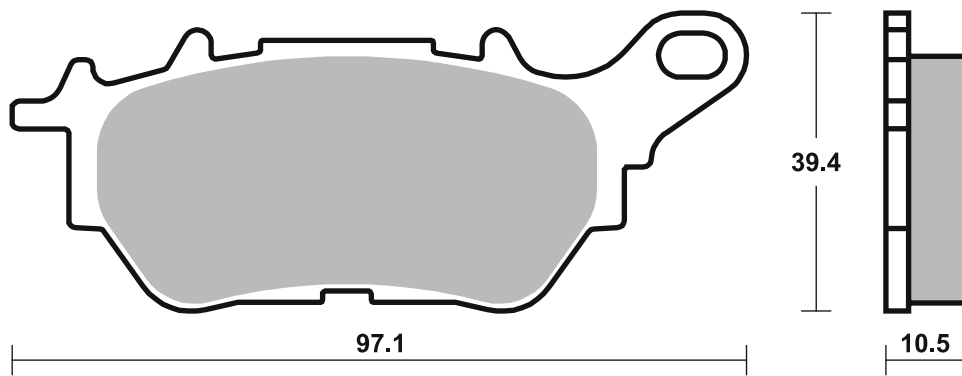
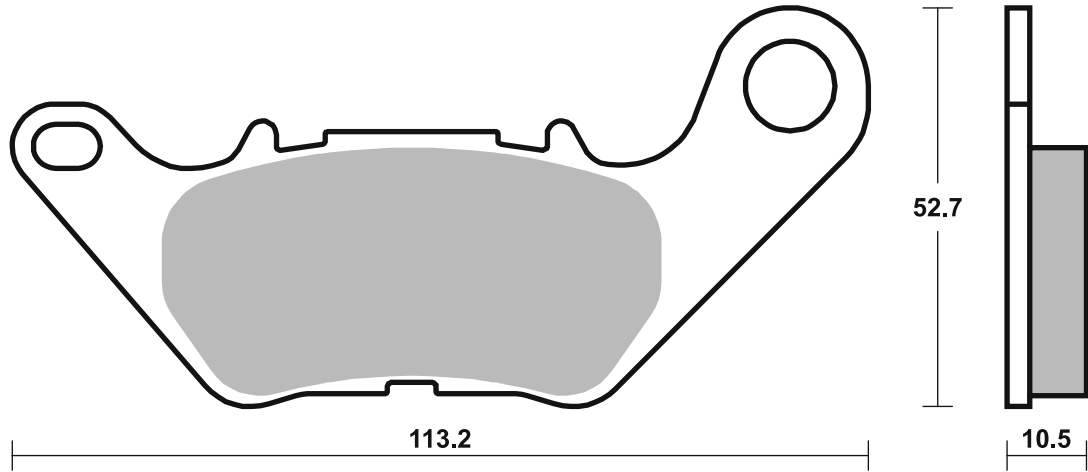

Available compounds

**HF • CT • MS**

**SBS 231**

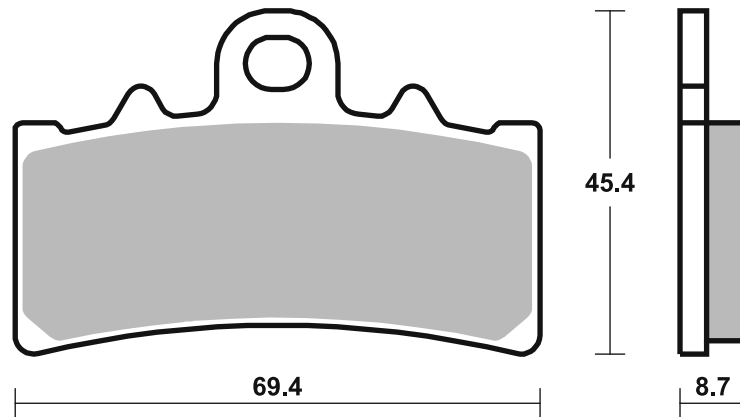



STREET  
AMERICAN  
SCOOTER

HF • HS • LS  
H.HF • H.CT • H.HS • H.LS  
HF • CT • MS

RACING  
OFF ROAD  
ATV

RST • DC • DCC • DS-1 • DS-2 • RQ  
SI • RSI • CS  
ATS • SI • RSI • PSI

Drawings 1:1

Available compounds

HF

SBS 232

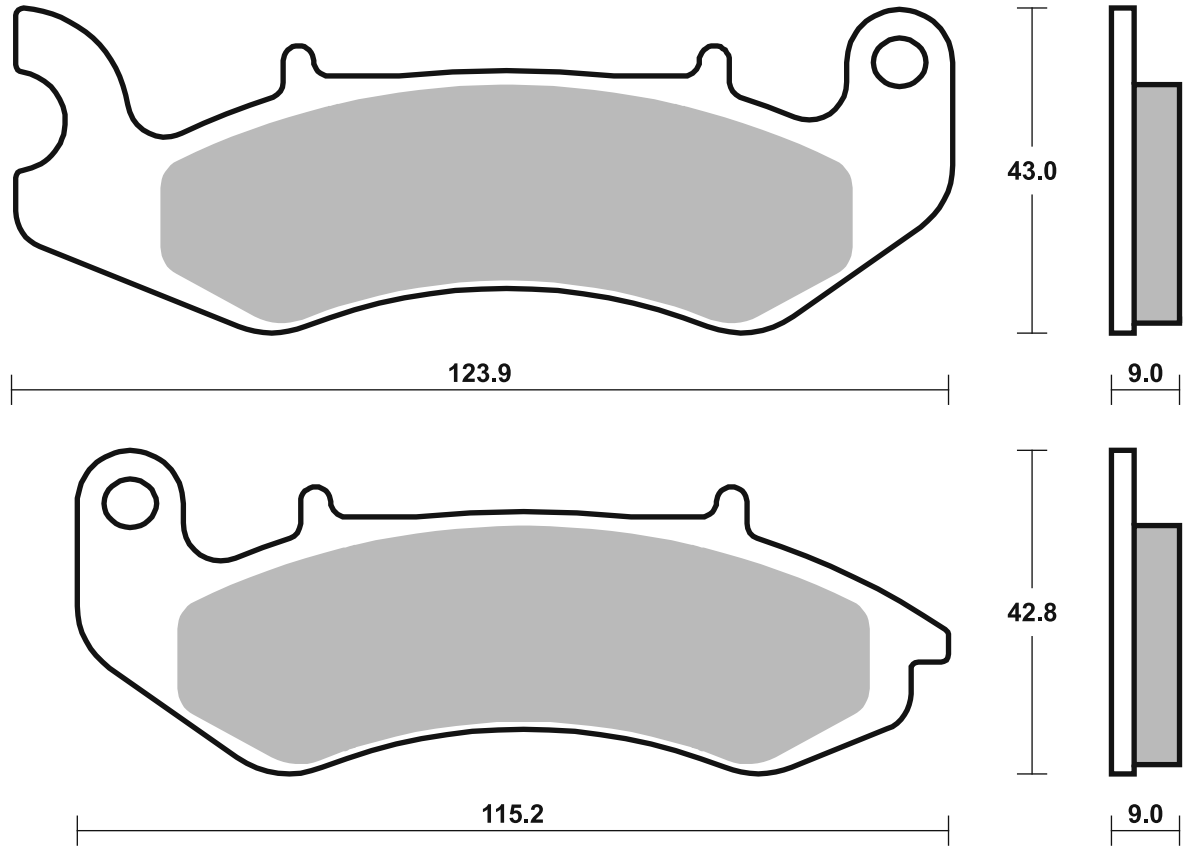

Available compounds

HF • CT • MS

SBS 233

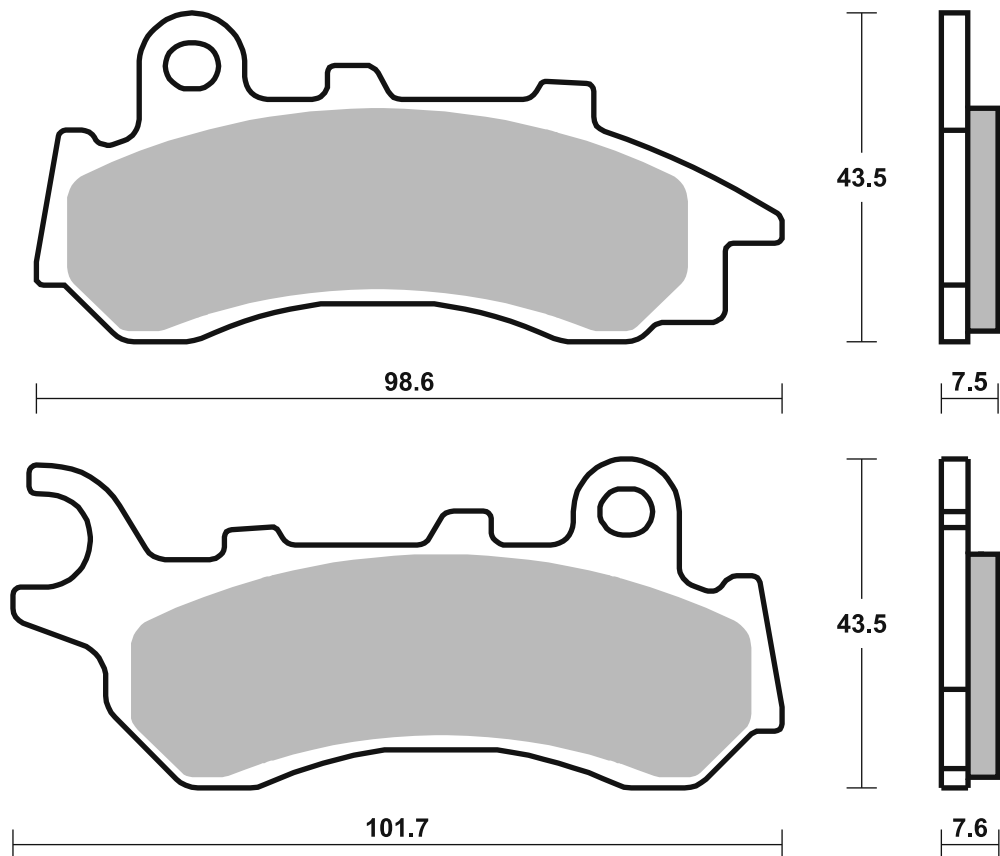

Dimensions in mm / Dimensions en mm  
1" = 25.4 mm, 1 mm = 0.04"

Brake Pad 1:1 Drawings,  
Compounds, Fitments



STREET  
AMERICAN  
SCOOTER

HF • HS • LS  
H.HF • H.CT • H.HS • H.LS  
HF • CT • MS

RACING  
OFF ROAD  
ATV

RST • DC • DCC • DS-1 • DS-2 • RQ  
SI • RSI • CS  
ATS • SI • RSI • PSI

Drawings 1:1

Available compounds

HF • CT

SBS 234

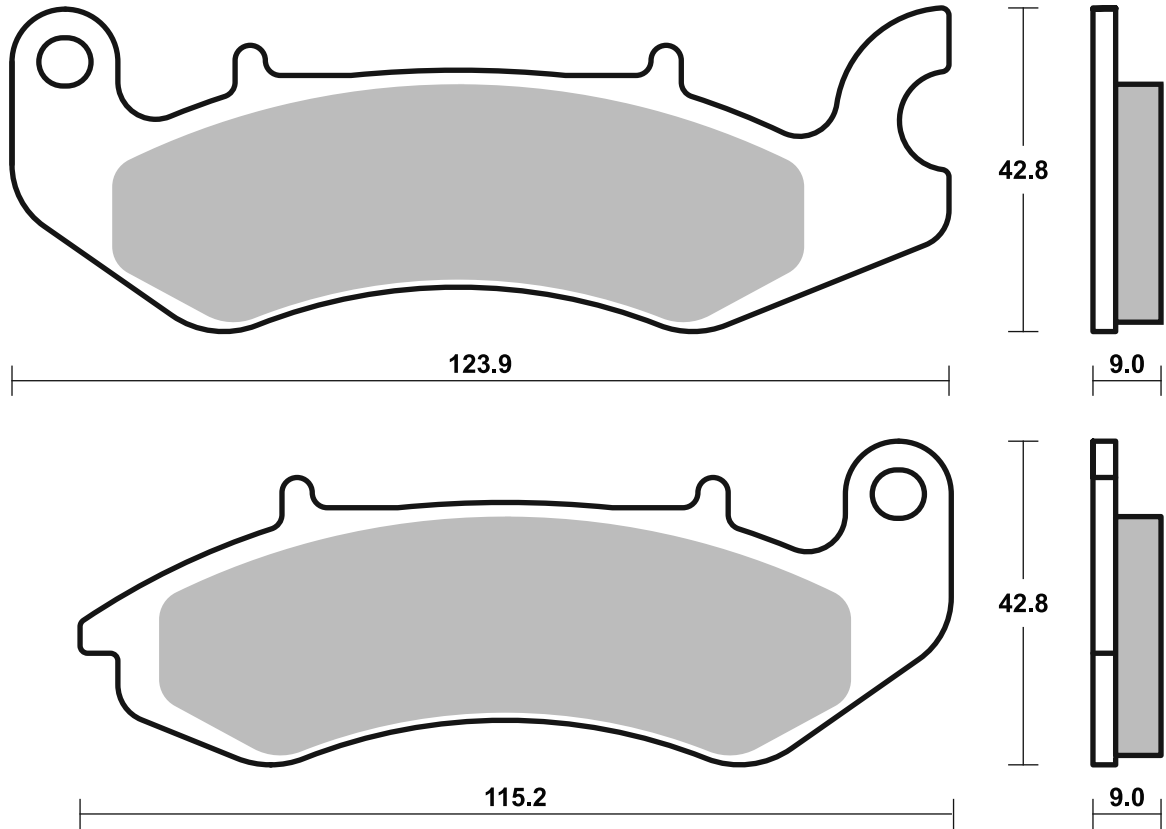

Available compounds

HF • CT

SBS 235

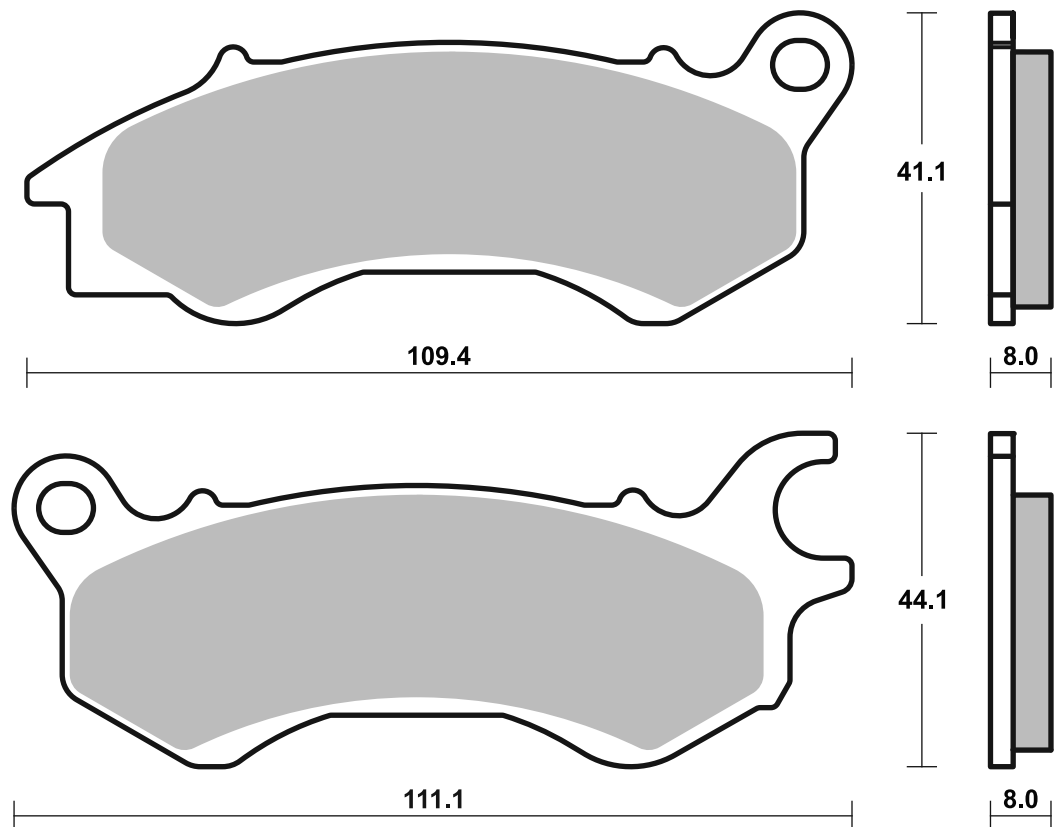

Applications

**SBS 236**

**Recommended compound**



**HONDA**

NSC	110 Vision	17 - 20	HF

**SBS 237**

**Recommended compound**



**APRILIA**

SR	50 Motard	18 - 22	HF
SXR	50	21 - 23	HF
SXR	160	21 - 23	HF

**PIAGGIO VESPA**

	50 Typhoon	18 - 22	HF

Brake Pad 1:1 Drawings,  
Compounds, Fitments

STREET  
AMERICAN  
SCOOTER

HF • HS • LS  
H.HF • H.CT • H.HS • H.LS  
HF • CT • MS

RACING  
OFF ROAD  
ATV

RST • DC • DCC • DS-1 • DS-2 • RQ  
SI • RSI • CS  
ATS • SI • RSI • PSI

Drawings 1:1

Available compounds

HF

SBS 236

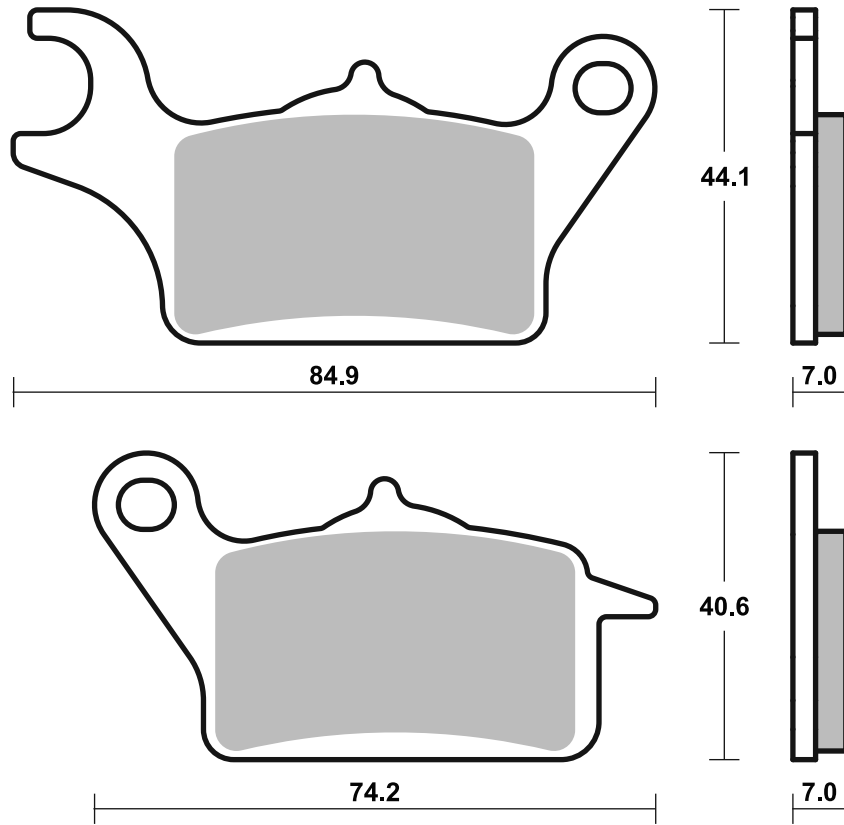

Available compounds

HF

SBS 237

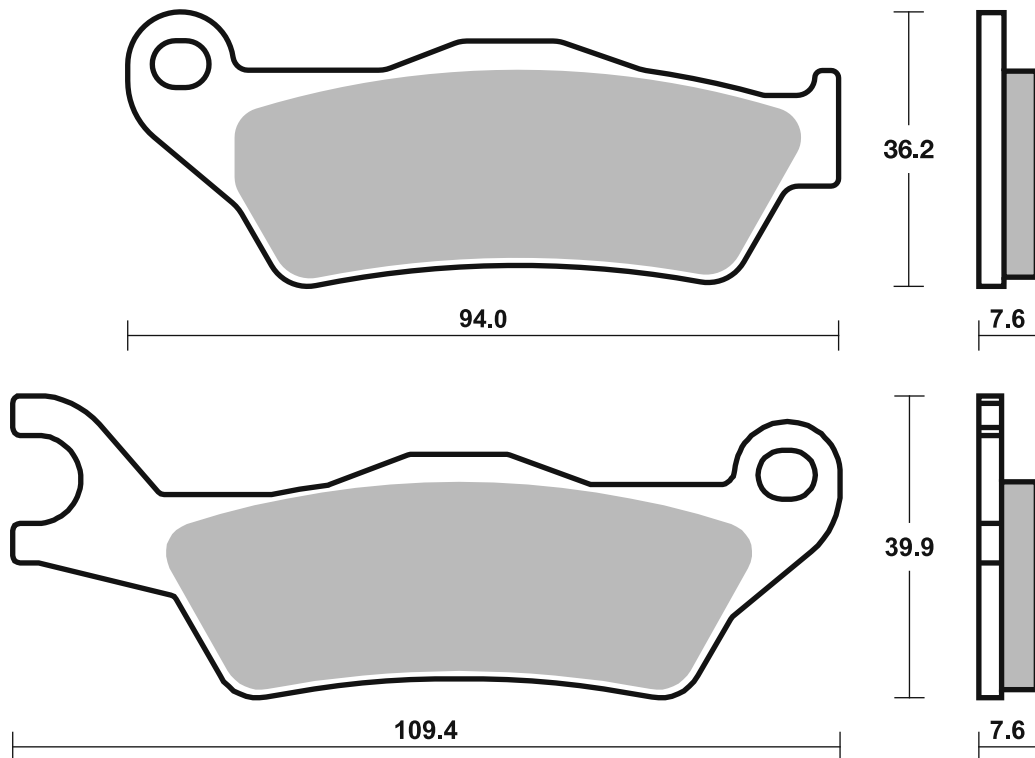





STREET  
AMERICAN  
SCOOTER

HF • HS • LS  
H.HF • H.CT • H.HS • H.LS  
HF • CT • MS

RACING  
OFF ROAD  
ATV

RST • DC • DCC • DS-1 • DS-2 • RQ  
SI • RSI • CS  
ATS • SI • RSI • PSI

Available compounds

HF

SBS 238

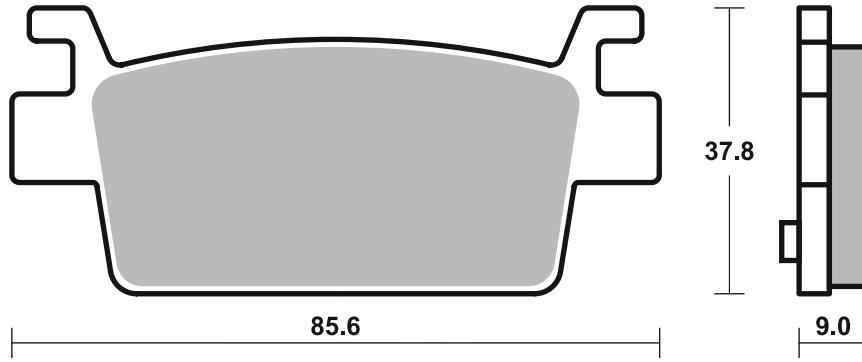

Available compounds

MS

SBS 239

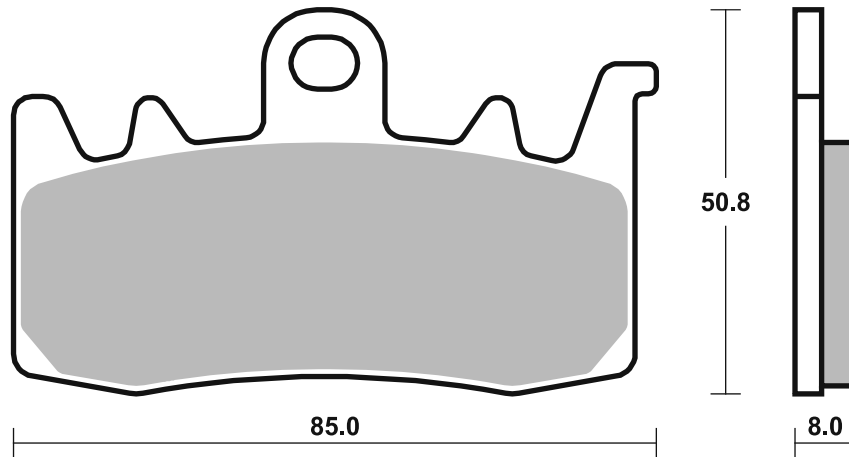

**SBS 240**

**Recommended compound**



**HONDA**

ADV	750 X-ADV	17 - 24	<b>HF</b>
NC	750 D Integra	14 - 19	<b>HF</b>
NC	750 Integra	16 - 18	<b>HF</b>
NC	750 Integra DCT ABS	14 - 19	<b>HF</b>

**SBS 241**

**Recommended compound**



**HONDA**

ADV	750 X-ADV	17 - 24	<b>MS</b>
-----	-----------	---------	-----------

STREET  
AMERICAN  
SCOOTER

HF • HS • LS  
H.HF • H.CT • H.HS • H.LS  
HF • CT • MS

RACING  
OFF ROAD  
ATV

RST • DC • DCC • DS-1 • DS-2 • RQ  
SI • RSI • CS  
ATS • SI • RSI • PSI

Drawings 1:1

Available compounds

**HF**

**SBS 240**

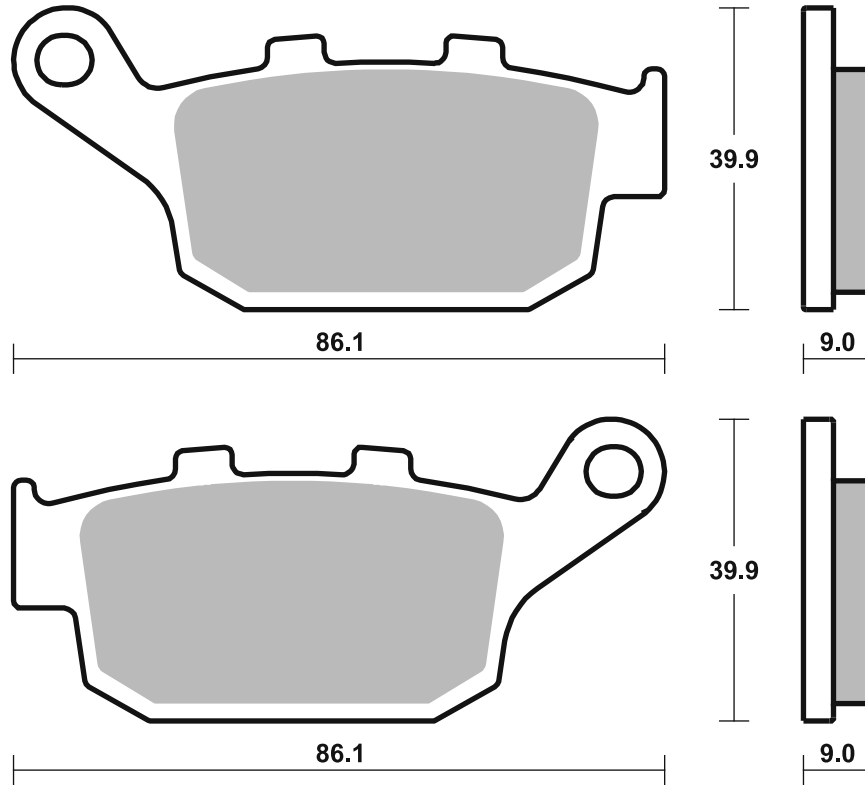

Available compounds

**MS**

**SBS 241**

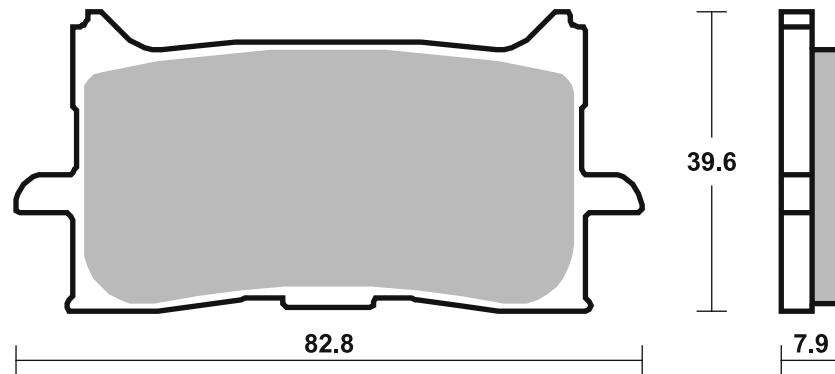



STREET  
AMERICAN  
SCOOTER

HF • HS • LS  
H.HF • H.CT • H.HS • H.LS  
HF • CT • MS

RACING  
OFF ROAD  
ATV

RST • DC • DCC • DS-1 • DS-2 • RQ  
SI • RSI • CS  
ATS • SI • RSI • PSI

Available compounds

MS

SBS 242

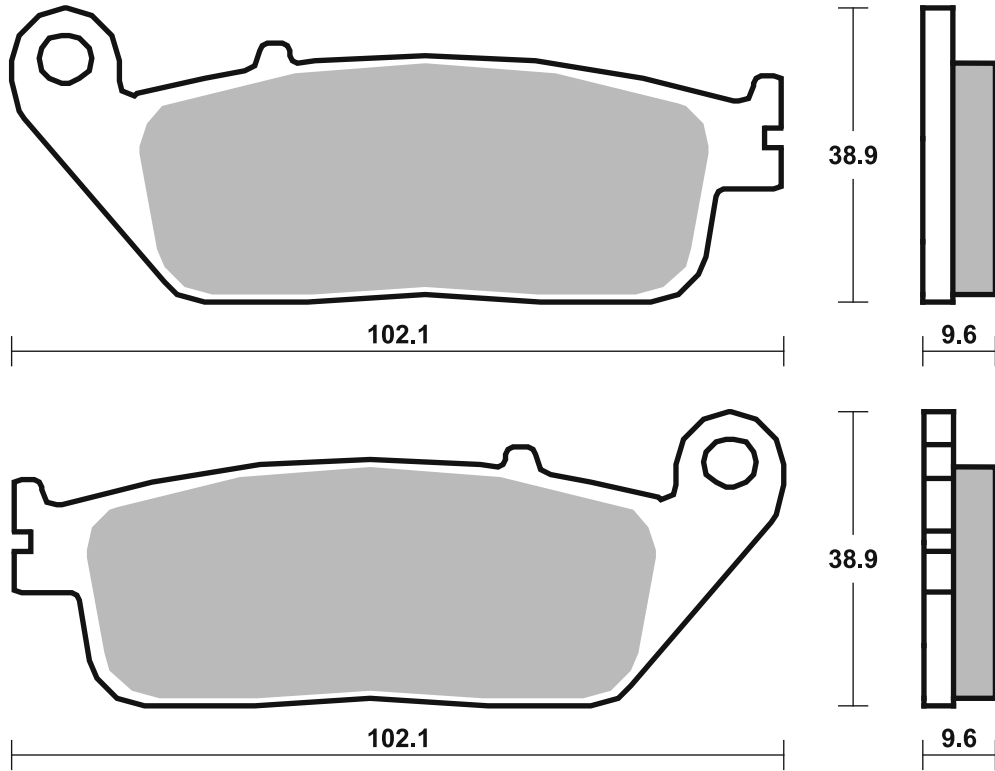

**Applications**

**SBS 500 Recommended compound**



<b>YAMAHA</b>			
FS	50 DX	75 - 79	<b>HF</b>
FS1	50 DX	77 - 78	<b>HF</b>
RD	50	76 - 78	<b>HF</b>
RD	90	76 - 79	<b>HF</b>
RD	100 D	76 - 79	<b>HF</b>
RS	100 DX	77 - 79	<b>HF</b>
RX	100	76 - 79	<b>HF</b>
RD	125 DX	75 - 77	<b>HF</b>
RS	125 DX	76 - 79	<b>HF</b>
RD	200 DX	76 - 77	<b>HF</b>

**SBS 501 Recommended compound**



<b>HONDA</b>			
CB	250 G, T	74 - 76	<b>HF</b>
CJ	250 T	76 - 78	<b>HF</b>
CB	350 F, F1	73 - 76	<b>HF</b>
CB	360 G, T	73 - 76	<b>HF</b>
CJ	360 T	76 - 78	<b>HF</b>
CL	360	74 - 77	<b>HF</b>
CB	400 F, F1, F2	75 - 79	<b>HF</b>
CB	450 K5, K6, K7	72 - 77	<b>HF</b>
CB	500 F	72 - 75	<b>HF</b>
CB	500 T	75 - 78	<b>HF</b>
CB	550 F	75 - 79	<b>HF</b>
CB	550 K	74 - 78	<b>HF</b>
CB	750 A	76 - 78	<b>HF</b>
CB	750 F1	75 - 76	<b>HF</b>
CB	750 K Four	77 - 78	<b>HF</b>

**SBS 502 Recommended compound**



<b>HONDA</b>			
CB	750 K0-K6 Four	70 - 76	<b>HF</b>

Brake Pad 1:1 Drawings,  
Compounds, Fitments

STREET HF • HS • LS  
 AMERICAN H.HF • H.CT • H.HS • H.LS  
 SCOOTER HF • CT • MS

RACING  
 OFF ROAD  
 ATV

RST • DC • DCC • DS-1 • DS-2 • RQ  
 SI • RSI • CS  
 ATS • SI • RSI • PSI

Drawings 1:1

Available compounds HF

SBS 500

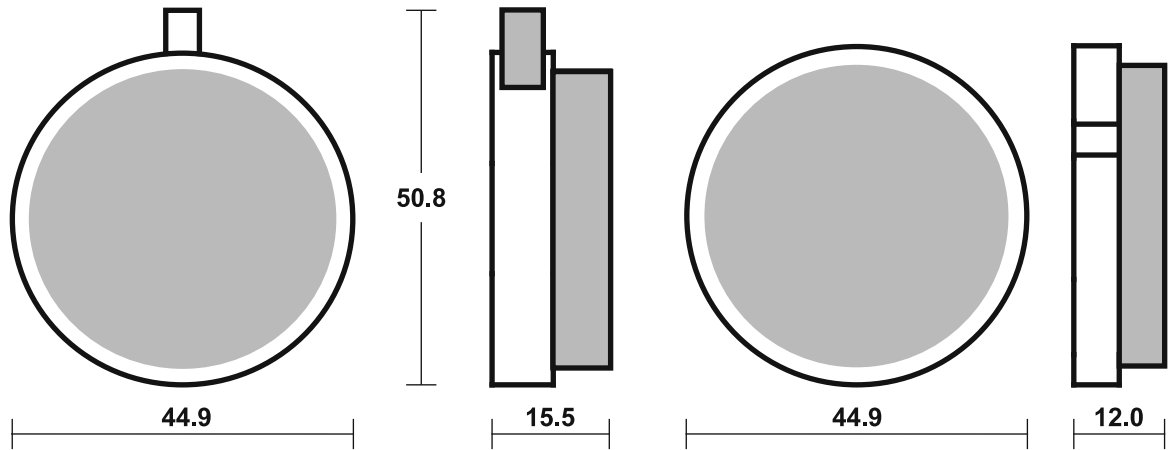

Available compounds HF • DCC

SBS 501

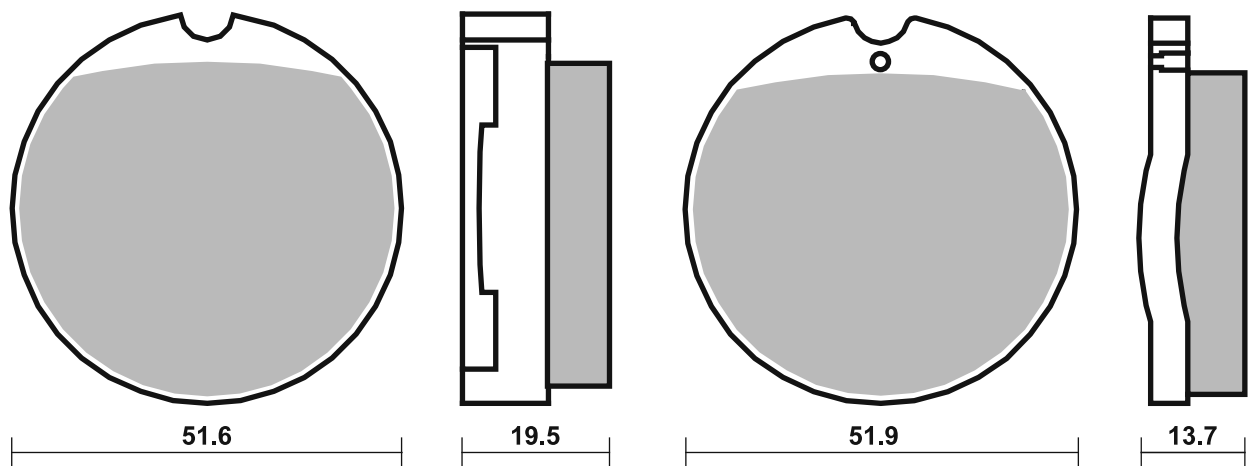

Available compounds HF

SBS 502

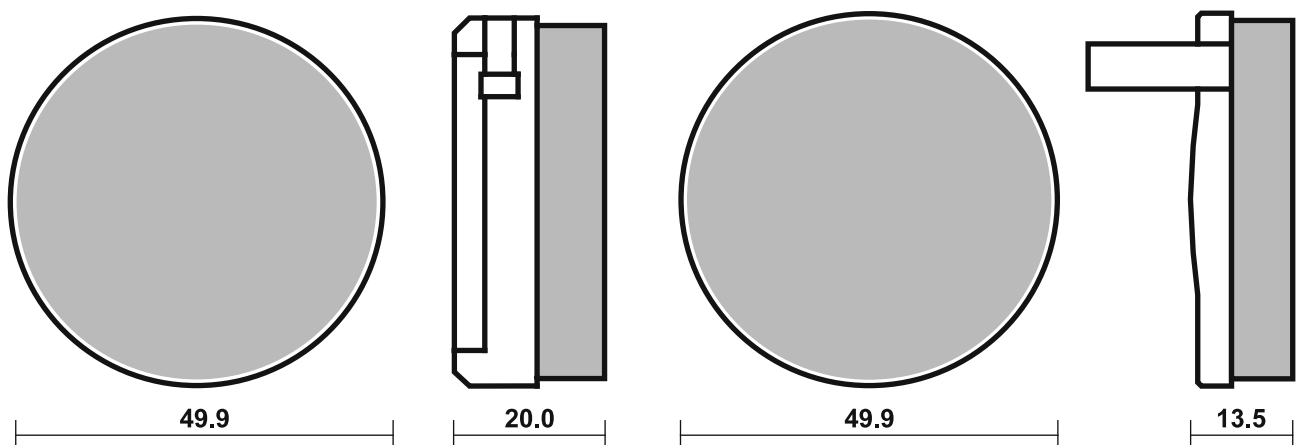

Brake Pad 1:1 Drawings,  
 Compounds, Fitments

## Applications

### SBS 503

### Recommended compound



<b>KAWASAKI</b>			
S2A	350	73 - 73	HF
S3	400	74 - 75	HF
S3A	400	74 - 75	HF
KH	500 H1	74 - 75	HF
Z	750 H	72 - 75	HF
Z1	900 Z1 A, Z1 B	73 - 75	HF
<b>SUZUKI</b>			
RE	5M, A	75 - 77	HF
RM	50	75 - 76	HF
GT	100	78 - 78	HF
GT	125	75 - 77	HF
GT	185	75 - 77	HF
RG	185	75 - 77	HF
GT	250	73 - 77	HF
GT	380	73 - 77	HF
GT	500	75 - 77	HF
GT	550	73 - 77	HF



<b>SUZUKI</b>			
GT	750	73 - 77	HF

### SBS 504

### Recommended compound



<b>ISR CALIPERS</b>			
2 Piston (22-023/026)			

<b>YAMAHA</b>			
RD	250	73 - 76	HF
RD	250	77 - 77	HF HF
TZ	250	82 - 85	HF
RD	350	73 - 79	HF
XS	360 B	76 - 76	HF
RD	400	73 - 76	HF
RD	400	77 - 77	HF HF
TX	500 A, B	74 - 77	HF
XS	500	75 - 76	HF
TX	650	72 - 73	HF
XS	650	75 - 77	HF
TX	750	73 - 74	HF
TX	750 A	73 - 76	HF

### SBS 505

### Recommended compound



<b>NORTON</b>			
MK2	850 Commando	73 - 75	HF
MK3	850 Commando	75 - 77	HF HF

Brake Pad 1:1 Drawings, Compounds, Fitments



STREET HF • HS • LS  
 AMERICAN H.HF • H.CT • H.HS • H.LS  
 SCOOTER HF • CT • MS

RACING  
 OFF ROAD  
 ATV

RST • DC • DCC • DS-1 • DS-2 • RQ  
 SI • RSI • CS  
 ATS • SI • RSI • PSI

Drawings 1:1

Available compounds HF

SBS 503

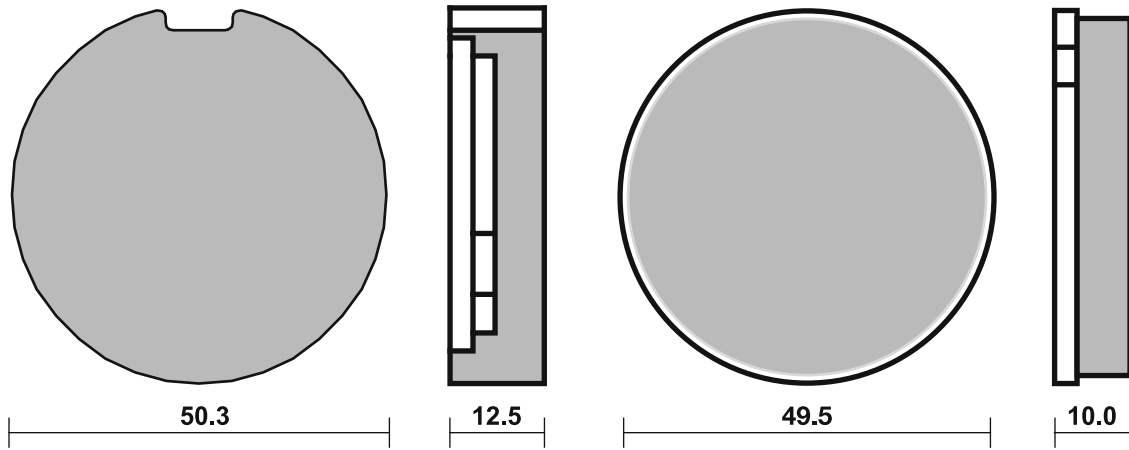

Available compounds

HF • DCC

SBS 504

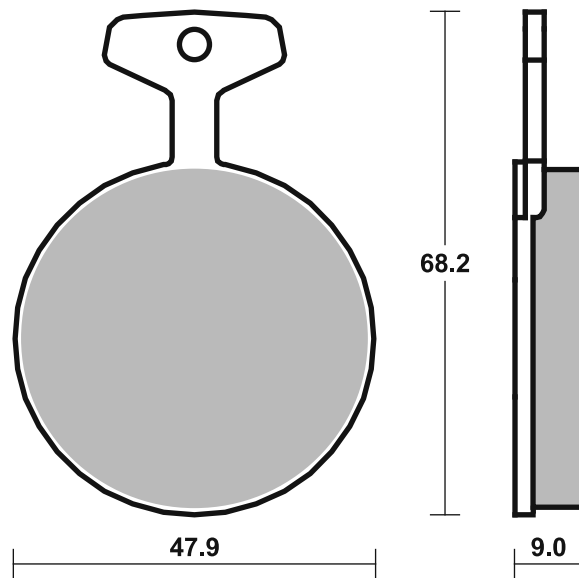

Available compounds

HF

SBS 505

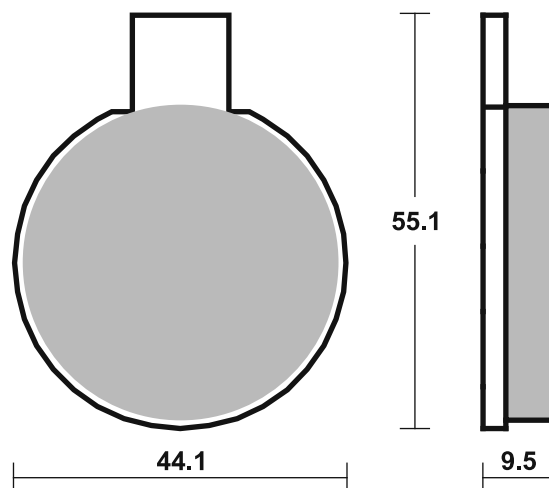

Brake Pad 1:1 Drawings,  
 Compounds, Fitments



<b>APRILIA</b>			
AF1	250 Replica	90 - 90	HF

<b>BENELLI</b>			
	350 4T Turismo	80 - 80	HF
	354	78 - 82	HF
	500 4T	76 - 76	HF
	750 Sei	75 - 78	HF
	900 Sei	84 - 84	HF

<b>BERINGER</b>			
2 Piston Classic Billet Caliper			

<b>BIMOTA</b>			
	all models	82 - 88	HF
SB3	1000 D	83 - 83	HF

<b>BMW</b>			
R65	650 GS	87 - 92	HF
R65	650 LS	82 - 85	HF
R65/1	650	86 - 86	HF
K75	750	90 - 90	LS
K75	750 C	85 - 88	HF
K75	750 RT	91 - 96	LS
K75	750 S, C	85 - 95	HF
R80	800	77 - 85	HF
R80	800 G/S P.-D.	86 - 86	HF
R80	800 GS	81 - 87	HF
R80	800 GS	91 - 92	HS
R80	800 R	91 - 95	LS
R80	800 RT	83 - 83	HF
R80/7	800	79 - 81	HF
K1	1000	89 - 89	LS
K100	1000 LT	87 - 87	HF
K100	1000 LT	92 - 94	LS
K100	1000 LT ABS	89 - 89	LS
K100	1000 RS	90 - 92	LS
K100	1000 RS ABS	88 - 89	LS
K100	1000 RS, RT	83 - 89	HF
R100	1000	81 - 84	HF
R100	1000 CS,RS, RT	81 - 84	HF
R100	1000 R	91 - 95	LS
R100	1000 RS	76 - 80	HF
R100	1000 RS	93 - 95	LS
R100	1000 S	78 - 80	HF
R100	1000 T	79 - 84	HF
K1100	1100 LT/SE	92 - 00	LS
K1100	1100 RS	93 - 96	LS
R1100	1100 RS	93 - 01	LS
K	1200 GT (K41)		
	With Integral		
	ABS	02 - 05	LS
K	1200 RS	97 - 05	LS

<b>BREMBO RACING CALIPERS</b>			
108N, P2 38			
F08			

<b>CZ</b>			
CZ	180	93 - 93	HF

<b>DUCATI</b>			
	250 Desmo	70 - 77	HF
	350 Desmo	70 - 77	HF
	350 F3	86 - 90	HF
	500 Sport	77 - 82	HF
	600 Pantah TL, SL	78 - 89	HF
	600 SL, TL Pantah	76 - 89	HF
	650 Pantah	84 - 89	HF
	750 F1	86 - 98	HF
	750 GT	74 - 76	HF



<b>DUCATI</b>			
	750 Paso	86 - 88	HF
	750 Sport	90 - 90	HS
	750 SS	74 - 76	HF
	750 SS	91 - 98	HF
	851 Strada	91 - 92	HF
	860 GT	75 - 77	HF
	860 GT	85 - 85	HF
	888 Roche Replica	91 - 91	HF
	900 GTS	77 - 79	HF
	900 Mike Hailwood		
	Replica	85 - 86	HF
	900 Paso	89 - 89	HF
	900 S2 Desmo	85 - 85	HF
	900 Sport	77 - 78	HF
	900 SS	78 - 89	HF
	1000 /6 Mike Hailwood		
	Replica	85 - 86	HF
	1000 Mille Replica	84 - 85	HF
	1000 S2 Desmo	85 - 85	HF

<b>HERCULES</b>			
	125 Silver Star		
	Classic	93 - 93	HF

<b>HOREX</b>			
	80 Rebell T	86 - 86	HF
	80 Sport L	86 - 86	HF
	125 Imperator	96 - 96	HF
	125 Regent	96 - 96	HF
	560 E	86 - 88	HF
	600 Columbus	87 - 88	HF

<b>INDIAN</b>			
	1700 Chief Blackhawk	11 - 13	H.LS
	1700 Chief Bomber	10 - 13	H.LS
	1700 Chief Classic	10 - 13	H.LS
	1700 Chief Dark Horse	10 - 13	H.LS
	1700 Chief Deluxe	09 - 13	H.LS
	1700 Chief		
	Roadmaster	09 - 13	H.LS
	1700 Chief Standard	09 - 13	H.LS
	1700 Chief Vintage	09 - 13	H.LS

<b>JAWA</b>			
CZ	125 2T	95 - 00	HF
CZ	125 MX	95 - 00	HF
CZ	180	92 - 92	HF
	300 Trail	93 - 93	HF

<b>LAVERDA</b>			
SFC	500	81 - 83	HF
SFC	600	86 - 89	HF
	650 V-Six	93 - 93	HS
SF2	750	74 - 78	HF
SF3	750	74 - 78	HF
SF3	750 RGS Corsa,		
	Executive	77 - 79	HF
	1000 Jota	76 - 79	HF
3C	1000 3CE, 3CL	74 - 75	HF
RGS	1000	83 - 83	HF
RGS	1000 Jota	86 - 86	HF
SFC	1000	85 - 86	HF
TGA	1000 Executive	84 - 84	HF
	1200 Mirage	78 - 80	HF

<b>MOTO-GUZZI</b>			
NTX	350	90 - 90	HF
V35	350 C	82 - 86	HF
V35	350 Florida	85 - 86	HF
V35	350 GT	90 - 90	HF



<b>MOTO-GUZZI</b>			
V35	350 III	87 - 87	HF
V35	350 TT	86 - 86	HF
NTX	650	90 - 02	HF
V65	650 Florida	86 - 94	HF
V65	650 GT	90 - 94	HF
NTX	750	90 - 93	LS
S3	750	75 - 76	HF
SP	750	91 - 92	HS
V75	750	86 - 88	HF
V75	750 Duna	86 - 90	HF
V75	750 TT Paris-Dakar	86 - 86	HF
	850 Le Mans	76 - 79	HF
T	850	74 - 76	HF
T3	850	75 - 80	HF
T4	850	75 - 82	HF
T5	850	75 - 88	HF
T5	850 N.T.	86 - 88	HF
	1000 California II	85 - 88	HF
	1000 California III C	91 - 95	HS
	1000 California III,		
	Fuel Injection	89 - 89	HF
	1000 Daytona	91 - 02	HF
	1000 Le Mans IV	85 - 89	HF
	1000 Le Mans, V	90 - 98	HS
GT	1000 V	91 - 91	HS
S	1000	90 - 90	HS
SP	1000 III	91 - 94	HS
SP	1000 Le Mans	79 - 83	HF
V	1000 Strada	93 - 94	HF
	1100 California	96 - 99	HS

<b>MZ</b>			
	125 Roadstar	92 - 94	HF
	125 Sportstar	93 - 98	HF
ETZ	125	82 - 92	HF
ETZ	150	82 - 95	HF
ETZ	250	82 - 84	HF
	251 (MUZ) Sportstar	96 - 98	HF
	251 Saxon Tour	93 - 98	HF
ETZ	251	89 - 89	HF
ETZ	300 LUX	90 - 90	HF
ETZ	300 X	88 - 88	HF
	301 (MUZ) Sportstar	96 - 98	HF
	301 Saxon Tour	93 - 98	HF
ETZ	301	90 - 92	HF
	500 Saxon Country	92 - 98	HF
	500 Saxon Fun	92 - 98	HF
	500 Saxon Voyager	93 - 98	HF
	500 Silver Star		
	Classic	93 - 98	HF

<b>NORTON</b>			
	600 Commander	90 - 90	HF
	600 Interpol	83 - 88	HF
	600 Wankel Classic	88 - 89	HF
F-1	600	90 - 90	HF

<b>OSSA</b>			
	500 Yanqee	78 - 78	HF

<b>SWM</b>			
XP	350 Sahara	83 - 83	HF

<b>TRIUMPH</b>			
	750 Bonneville U.K.	87 - 87	HF

<b>ZUNDAPP</b>			
KS	175	78 - 82	HF

STREET HF • HS • LS  
AMERICAN H.HF • H.CT • H.HS • H.LS  
SCOOTER HF • CT • MS

RACING  
OFF ROAD  
ATV

RST • DC • DCC • DS-1 • DS-2 • RQ  
SI • RSI • CS  
ATS • SI • RSI • PSI

Drawings 1:1

Available compounds

HF • HS • LS • RST • DCC • DS-1 • DS-2 • H.HF • H.CT • H.LS

SBS 506

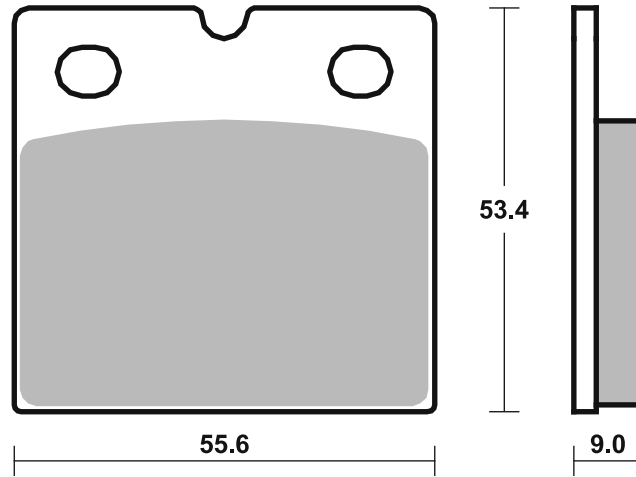

Brake Pad 1:1 Drawings,  
Compounds, Fitments

**Applications**

**SBS 507**

**Recommended compound**



<b>YAMAHA</b>			
XS	250 C	77 - 78	HF
XS	250 D, E	79 - 80	HF
XS	360 C, D	77 - 77	HF
RD	400	79 - 79	HF
SR	400	77 - 77	HF
XS	400	77 - 77	HF
SR	500	78 - 91	HF
XS	500	77 - 81	HF
XJ	650	80 - 82	HF
XJ	650 RJ Seca	81 - 83	HF
XS	650	78 - 85	HF
XS	650	80 - 82	HF
XS	650 SE	80 - 82	HF
XS	650 SJ, SK	82 - 82	HF
XS	650 SK, Heritage	83 - 83	HF
XJ	750 E	81 - 83	HF
XS	750	77 - 80	HF
XS	750 H, J, K	81 - 82	HF



<b>YAMAHA</b>			
XS	750 SE	79 - 80	HF
XS	850	80 - 80	HF
XV	920	81 - 82	HF
XV	1000 TR1	81 - 83	HF
XS	1100 E,F,G,H	78 - 81	HF
XS	1100 SF, SG, SH, LG	79 - 81	HF

**SBS 508**

**Recommended compound**



<b>HONDA</b>			
CB	750 SS	77 - 79	HF
GL	1000 K1,		
	K2 Gold Wing	75 - 77	HF

**SBS 509**

**Recommended compound**



<b>HONDA</b>			
CB	750 F1	75 - 76	HF
GL	1000 K1,		
	K2 Gold Wing	75 - 77	HF
GL	1000 K3 Gold Wing	78 - 79	HF

<b>PERFORMANCE MACHINE</b>			
	162 X 2		

Brake Pad 1:1 Drawings, Compounds, Fitments

STREET HF • HS • LS  
AMERICAN H.HF • H.CT • H.HS • H.LS  
SCOOTER HF • CT • MS

RACING  
OFF ROAD  
ATV

RST • DC • DCC • DS-1 • DS-2 • RQ  
SI • RSI • CS  
ATS • SI • RSI • PSI

Drawings 1:1

Available compounds

HF

SBS 507

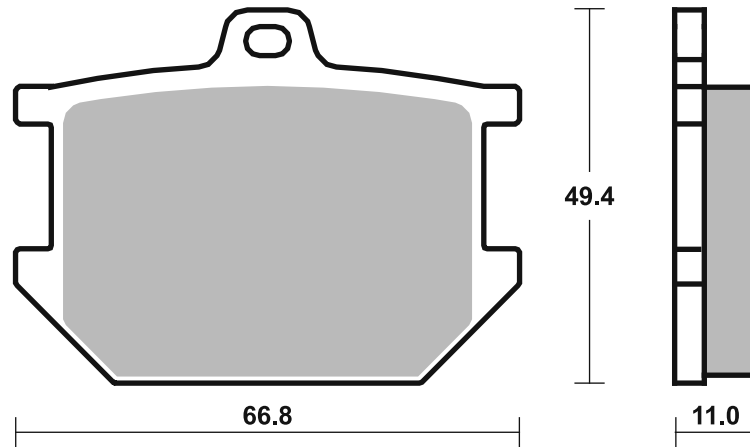

Available compounds

HF

SBS 508

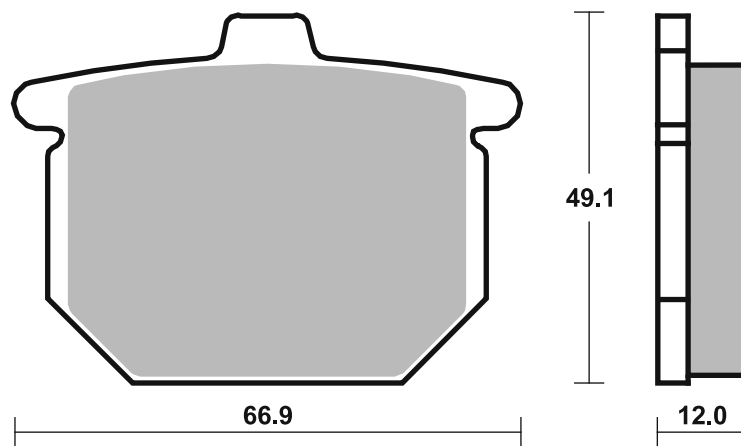

Available compounds

HF • H.HF • H.CT

SBS 509

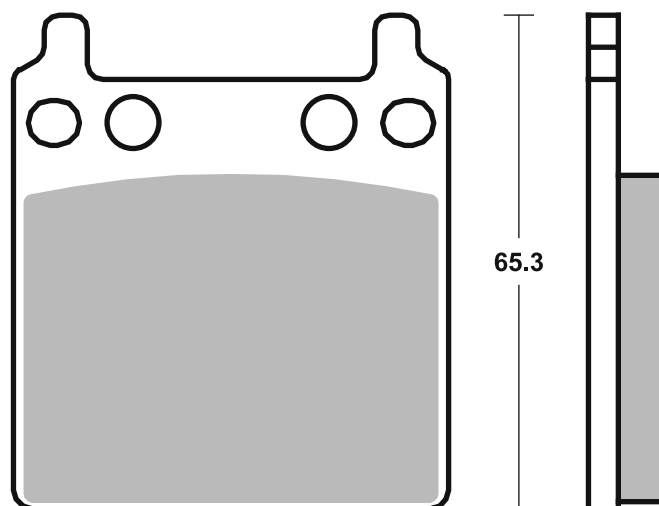

**SBS 510 Recommended compound**



<b>KAWASAKI</b>			
KH 250	76 - 80	<b>HF</b>	
Z 250	78 - 80	<b>HF</b>	
KH 400	76 - 78	<b>HF</b>	
Z 400	79 - 79	<b>HF</b>	
Z 400 C1	80 - 85	<b>HF</b>	
Z 440 C	80 - 81	<b>HF</b>	
Z 440 LTD	80 - 81	<b>HF</b>	
KH 500	76 - 79	<b>HF</b>	
Z 500	79 - 80	<b>HF</b>	
Z 550	80 - 80	<b>HF</b>	
Z 650	78 - 80	<b>HF</b>	
Z 750 B	76 - 79	<b>HF</b>	
Z 750 LTD	80 - 80	<b>HF</b>	
Z 900 A	76 - 77	<b>HF</b>	
Z 1000	76 - 81	<b>HF</b>	
Z 1000 GL	80 - 82	<b>HF</b>	
Z 1000 H1	80 - 83	<b>HF</b>	
Z 1000 LTD	77 - 79	<b>HF</b>	

<b>KAWASAKI</b>			
Z 1000 R	78 - 79	<b>HF</b>	

**SBS 511 Recommended compound**



<b>SUZUKI</b>			
GS 400	77 - 78	<b>HF</b>	
GS 425	79 - 79	<b>HF</b>	
GS 750	76 - 77	<b>HF</b>	
GS 750 D	77 - 79	<b>HF</b>	
GS 750 E	77 - 79	<b>HF</b>	
GS 850	79 - 80	<b>HF</b>	

**SBS 512 Recommended compound**



<b>GMA</b>			
2 Piston Caliper, large Model A			
<b>KAWASAKI</b>			
Z 500	79 - 80	<b>HF</b>	
Z 650	78 - 80	<b>HF</b>	
Z 1000	76 - 81	<b>HF</b>	
Z 1000 F1	80 - 82	<b>HF</b>	
Z 1000 GL	80 - 82	<b>HF</b>	
Z 1000 H1	80 - 83	<b>HF</b>	
Z 1000 MKII	79 - 80	<b>HF</b>	
Z 1000 R	78 - 79	<b>HF</b>	
Z 1000 ST	79 - 81	<b>HF</b>	
Z 1100 ST	81 - 83	<b>HF</b>	
Z 1300	79 - 81	<b>HF</b>	
Z 1300 DF1	84 - 84	<b>HF</b>	
<b>SUZUKI</b>			
GSX 250	81 - 82	<b>HF</b>	

<b>SUZUKI</b>			
GSX 250	86 - 87	<b>HF</b>	
GSX 400 F	81 - 84	<b>HF</b>	
GSX 400 FD	83 - 83	<b>HF</b>	
GSX 400 FWS	86 - 87	<b>HF</b>	
GSX 400 FX, FZ	81 - 82	<b>HF</b>	
GS 450	86 - 86	<b>HF</b>	
GS 500	80 - 85	<b>HF</b>	
GS 500 E (Austria)	78 - 79	<b>HF</b>	
GS 500 E (Austria)	81 - 82	<b>HF</b>	
GS 550	80 - 82	<b>HF</b>	
GR 650	83 - 84	<b>HF</b>	
GS 650	81 - 83	<b>HF</b>	
GS 650 G	83 - 87	<b>HF</b>	
GS 650 Turbo, XN	83 - 85	<b>HF</b>	
GS 700	85 - 85	<b>HF</b>	
GS 750	76 - 79	<b>HF</b>	
GS 750 D	77 - 79	<b>HF</b>	
GS 750 E	77 - 79	<b>HF</b>	

<b>SUZUKI</b>			
GS 750 SD	83 - 83	<b>HF</b>	
GSX 750 E	82 - 83	<b>HF</b>	
GSX 750 EF	80 - 86	<b>HF</b>	
GSX 750 ES	83 - 85	<b>HF</b>	
GSX 750 ES, EF, STS	86 - 88	<b>HF</b>	
GSX 750 L	80 - 82	<b>HF</b>	
GSX 750 S	82 - 82	<b>HF</b>	
GSX 750 S, Katana	85 - 86	<b>HF</b>	
GS 850	79 - 82	<b>HF</b>	
GS 850 G	83 - 86	<b>HF</b>	
GSX 850 G	83 - 85	<b>HF</b>	
XN 850	83 - 85	<b>HF</b>	
G 1000 SZ	82 - 82	<b>HF</b>	
GS 1000	78 - 81	<b>HF</b>	
GS 1000 ET	81 - 81	<b>HF</b>	
GS 1000 EX	81 - 81	<b>HF</b>	
GSX 1000 S, Katana	82 - 84	<b>HF</b>	
GS 1100	81 - 83	<b>HF</b>	

Brake Pad 1:1 Drawings, Compounds, Fitments

STREET HF • HS • LS  
 AMERICAN H.HF • H.CT • H.HS • H.LS  
 SCOOTER HF • CT • MS

RACING  
 OFF ROAD  
 ATV

RST • DC • DCC • DS-1 • DS-2 • RQ  
 SI • RSI • CS  
 ATS • SI • RSI • PSI

Drawings 1:1

Available compounds

HF

SBS 510

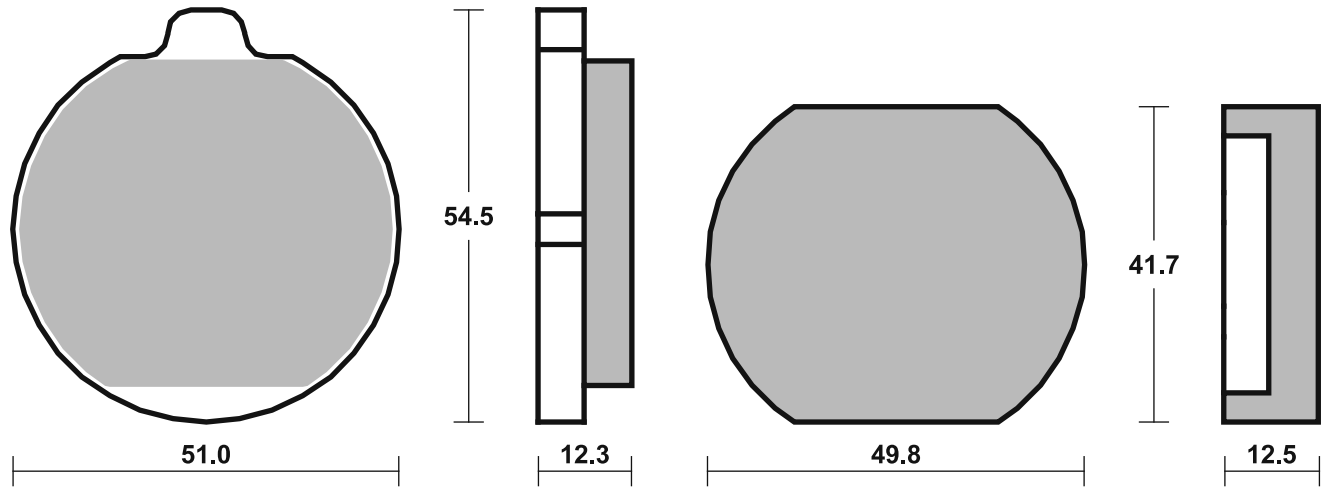

Available compounds

HF

SBS 511

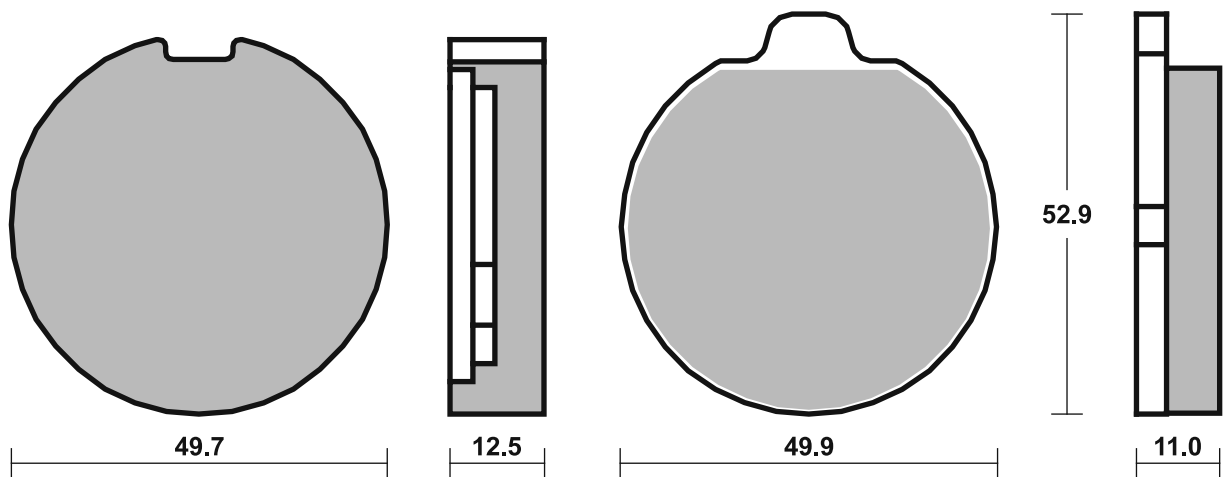

Available compounds

HF • H.HF • H.CT

SBS 512

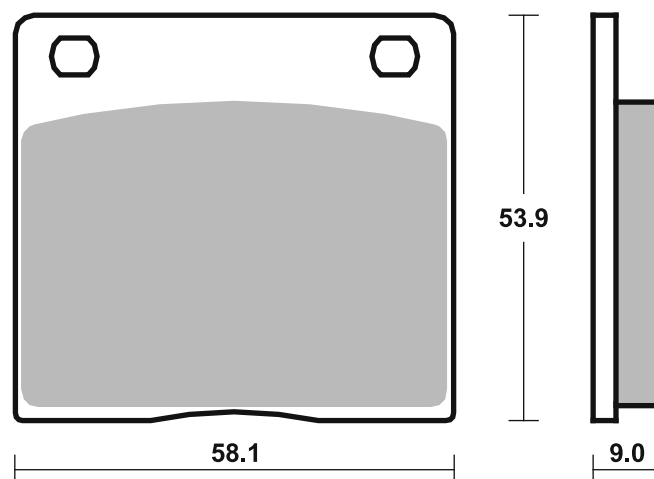

Brake Pad 1:1 Drawings,  
 Compounds, Fitments

# Applications

## SBS 512 Recommended compound



SUZUKI			
GS	1100 ED, ESD, GD	83 - 83	HF
GS	1100 G	86 - 88	HF
GS	1100 GKD, SD, GLD	83 - 83	HF
GS	1100 L	79 - 79	HF
GSX	1100	86 - 86	HF
GSX	1100 E	82 - 84	HF
GSX	1100 E, L	79 - 81	HF
GSX	1100 S	82 - 83	HF
GT	1100	80 - 80	HF
GV	1200 GLG Madura	86 - 86	HF
GV	1400 Cavalcade	85 - 86	HF

## SBS 513 Recommended compound



HARLEY DAVIDSON			
FXE	Series	74 - 77	H.HF
XLCH	1000	73 - 73	H.HF
FL	1200 FLH Police	75 - 79	H.HF H.HF
FLH	1200	74 - 76	H.HF H.HF
FLH	1200	80 - 80	H.HF
FLH	1200 Anniversary	78 - 78	H.HF H.HF
FLH	1200 Touring	77 - 78	H.HF H.HF
FLHS	1200	77 - 80	H.HF H.HF
FX	1200	74 - 80	H.HF
FXE	1200	74 - 80	H.HF
FXS	1200	78 - 79	H.HF
FLH	1340 80	78 - 81	H.HF H.HF
FLH	1340 80	81 - 81	H.HF
FLH	1340 Electra Glide	82 - 83	H.HF
FLH	1340 Electra Glide Spec.	84 - 84	H.HF
FXB	1340 80	80 - 81	H.HF
FXB	1340 Sturgis	82 - 82	H.HF



HARLEY DAVIDSON			
FXE	1340 80	78 - 81	H.HF
FXE	1340 Super Glide	83 - 84	H.HF
FXEF	1340 80 Fat Bob	79 - 81	H.HF
FXR	1340	78 - 81	H.HF
FXS	1340 80	79 - 81	H.HF
FXS	1340 Low Rider	82 - 82	H.HF
FXWG	1340 80	80 - 81	H.HF
FXWG	1340 Wide Glide	82 - 82	H.HF

## SBS 514 Recommended compound



KAWASAKI			
Z	750 B	76 - 79	HF
Z	1000 LTD	77 - 79	HF

Brake Pad 1:1 Drawings, Compounds, Fitments



STREET HF • HS • LS  
 AMERICAN H.HF • H.CT • H.HS • H.LS  
 SCOOTER HF • CT • MS

RACING  
 OFF ROAD  
 ATV

RST • DC • DCC • DS-1 • DS-2 • RQ  
 SI • RSI • CS  
 ATS • SI • RSI • PSI

Drawings 1:1

Available compounds

HF • H.HF • H.CT

SBS 512

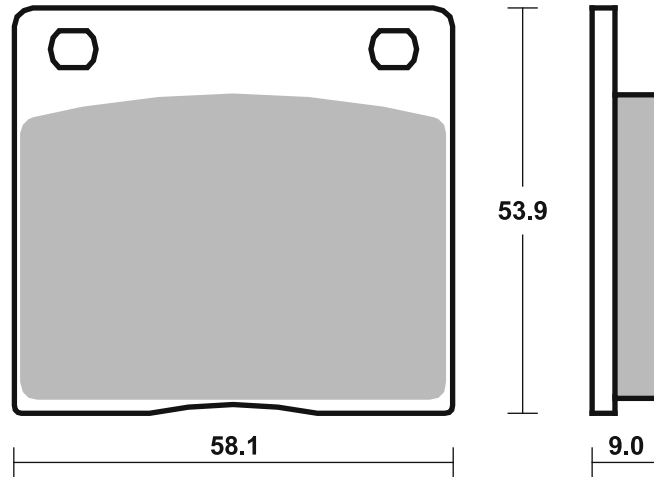

Available compounds

H.HF • H.CT

SBS 513

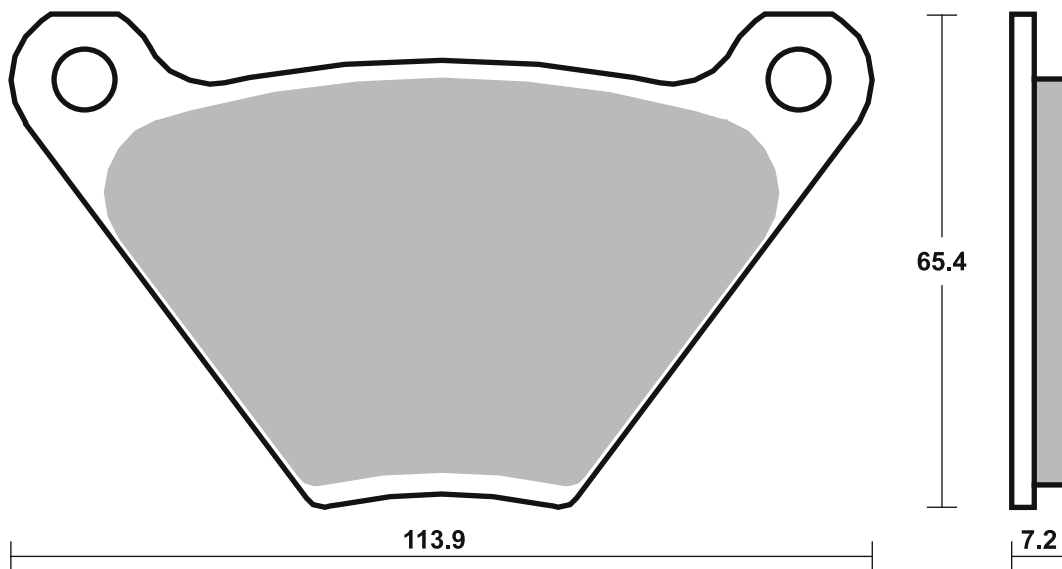

Available compounds

HF

SBS 514

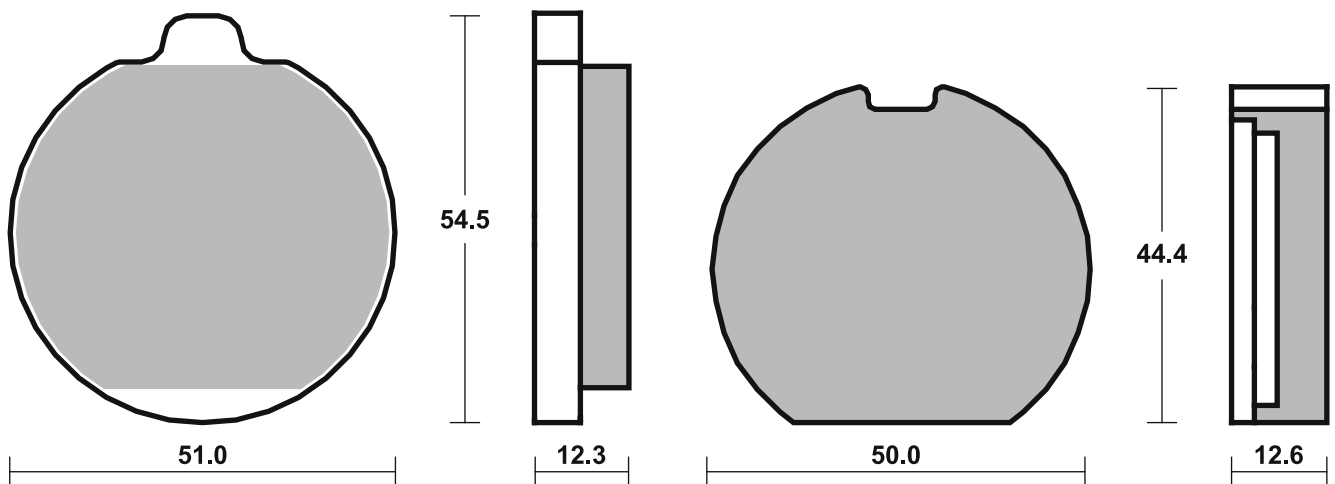

Brake Pad 1:1 Drawings,  
 Compounds, Fitsments

## Applications

### SBS 515 Recommended compound



<b>SUZUKI</b>			
GT	125	78 - 79	HF
RG	125	79 - 80	HF
GT	200 X5 (Nien)	79 - 82	HF
XS	200	79 - 79	HF
GT	250	78 - 81	HF
RG	250	78 - 82	HF
GT	380 Asco	77 - 77	HF
GS	400	79 - 82	HF
GS	425	80 - 80	HF
GS	500	80 - 81	HF
GS	500 E (Austria)	78 - 79	HF
GT	500	73 - 75	HF
GS	550	77 - 79	HF
GT	550	78 - 78	HF
GS	750	78 - 79	HF
GS	1000	78 - 79	HF

### SBS 516 Recommended compound



<b>KAWASAKI</b>			
KH	125	77 - 80	HF
Z	200	77 - 81	HF

<b>SUZUKI</b>			
AC	50 DX	81 - 86	HF
AC	50 RG, ZR, Z1	79 - 84	HF
GT	50	77 - 80	HF
X-1	50	79 - 79	HF

### SBS 517 Recommended compound



<b>HONDA</b>			
MT	125 R	78 - 78	HF
CB	400 N	78 - 82	HF
CB	400 NZ	79 - 79	HF
CX	400	81 - 81	HF
GL	400	77 - 80	HF
CX	500	78 - 80	HF
CB	750 F	77 - 80	HF HF
CB	750 SS	77 - 79	HF HF
CB	900 F	78 - 80	HF HF
CBX	1000	78 - 80	HF HF
GL	1000 Gold Wing	81 - 81	HF HF
GL	1000 Gr. Tour. Gold Wing	81 - 82	HF HF
GL	1000 K3 Gold Wing	78 - 79	HF HF
GL	1100 A Gold Wing	79 - 83	HF HF

STREET HF • HS • LS  
 AMERICAN H.HF • H.CT • H.HS • H.LS  
 SCOOTER HF • CT • MS

RACING  
 OFF ROAD  
 ATV

RST • DC • DCC • DS-1 • DS-2 • RQ  
 SI • RSI • CS  
 ATS • SI • RSI • PSI

Drawings 1:1

Available compounds

HF

SBS 515

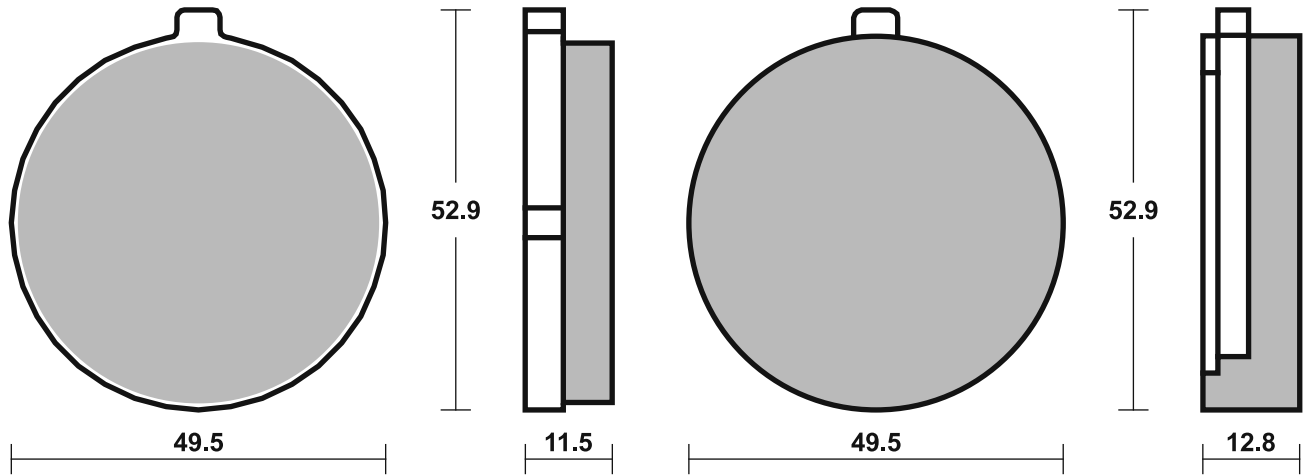

Available compounds

HF

SBS 516

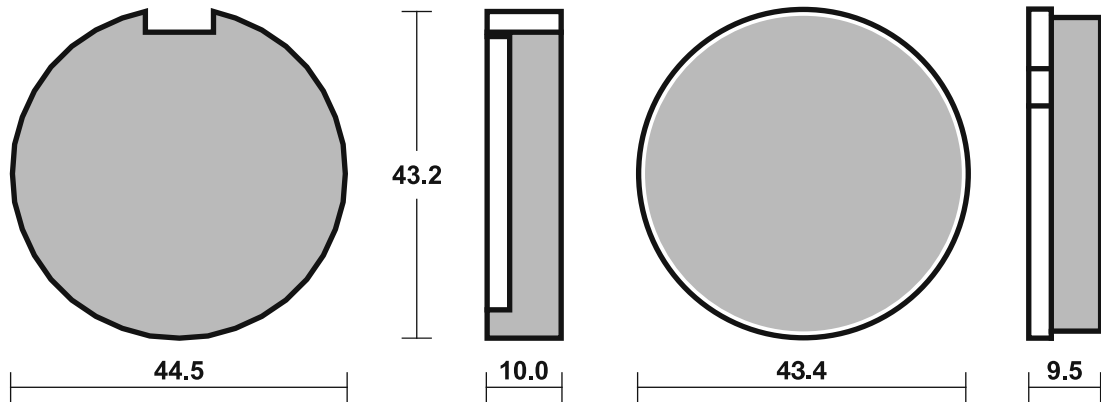

Available compounds

HF • DCC

SBS 517

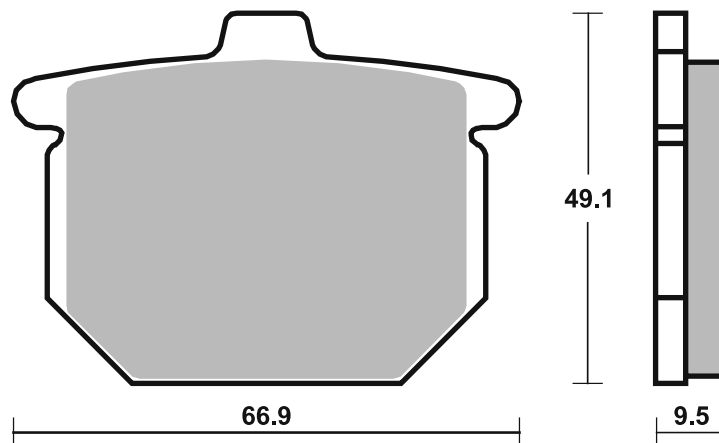

**Applications**

**SBS 518**

**Recommended compound**



**KAWASAKI**

Z	400 D, S	76 - 77	HF

**SBS 519**

**Recommended compound**



**ALFER**

MC	80	87 - 87	HF
MC	125	87 - 87	HF
MC	125	88 - 88	HF
GR	250 Enduro	85 - 85	HF
GR	250 Enduro	88 - 88	HF
MC	250	85 - 85	HF
MC	250	87 - 87	HF
GR	300	85 - 85	HF
GR	300 Enduro	88 - 88	HF

**APRILIA**

	50 Tuareg	85 - 85	HF
	125 Classic	96 - 03	HF
	125 Red Rose	89 - 97	HF
	125 Sport Pro.	92 - 92	HF
	125 Tuareg	87 - 92	HF
	125 Tuareg AS	86 - 86	HF
	125 Tuono	04 - 07	HF
AF1	125	87 - 87	HF
AF1	125 Europa, Futura	90 - 92	HF
AF1	125 Replica, Sintesi	89 - 91	HF
ETX	125 Tuareg	86 - 87	HF
	200 Climber	93 - 95	RSI
	250 Tuareg Rally	86 - 86	HF
MX	250 Cross	85 - 85	SI
RS	250	95 - 02	HF
RS	250 Pista	04 - 04	HF
RX	250	86 - 86	HF
	350 Tuareg	86 - 86	HF
	350 Tuareg	88 - 89	HF
	350 Tuareg Wind	87 - 88	HF
ETX	350	85 - 86	HF
ETX	350	87 - 92	SI
	600 Tuareg	86 - 87	HF
	600 Tuareg Wind	88 - 88	HF
ETX	600	86 - 92	HF

**ARMSTRONG**

MX	500	86 - 86	SI
MX	600	86 - 86	SI

**ASPES**

	125 Sintesi	88 - 88	HF
--	-------------	---------	----



**BENELLI**

	124 T	83 - 85	HF
	125 2CE	76 - 78	HF
	125 Custom	85 - 85	HF
	125 Jarno	89 - 89	HF
	125 Sport	82 - 89	HF
	125 T	76 - 76	HF
	125 TT	86 - 86	HF
BX	125	89 - 89	SI
BXK	125	88 - 88	HF
E	125 L.C.	85 - 85	HF
	250 2CE	76 - 76	HF
	250 Disc	76 - 76	HF
	304	83 - 83	HF
	350 4T Turismo	80 - 80	HF
	354	78 - 82	HF
	354 Sport	83 - 85	HF
	500 -4	76 - 76	HF
	500 4T	76 - 76	HF
	654 Sport	83 - 83	HF
	900 Tornado 3	00 - 06	LS
TNT	1100	04 - 04	LS

**BETA**

KR	50	86 - 87	HF
KR	50 Twin	88 - 88	HF
ALP	240	96 - 96	RSI
CR	250	83 - 83	SI
ALP	260	96 - 96	RSI
	500 GS, RV	84 - 84	HF

**BIMOTA**

YB7	400	89 - 89	HF
	500 Vdue	97 - 00	HF
	600 Bellaria	91 - 91	HF
YB9	600 SRI	97 - 97	HF
BB1	650 Supermono	97 - 00	HF
SB7	750	96 - 88	HF
YB4	750	89 - 89	HF
1D	851 Tesi	91 - 91	HF
1D	900 Tesi	93 - 93	HF
DB2	900	92 - 00	HF
DB3	900 Mantra	97 - 00	HF
DB4	900	99 - 00	LS
1D	906 Tesi	91 - 91	HF



**BIMOTA**

	1000 Furano	92 - 93	HF
2D	1000 Tesi	04 - 06	LS
SB8	1000 R	98 - 00	LS
SB8K	1000	06 - 06	LS
SB8K	1000 Santamonica	07 - 09	LS
YB11	1000	97 - 00	HF
YB6	1000	89 - 89	HF
YB8	1000	90 - 90	HF
	1002 Dieci	91 - 91	HF
DB7	1099	09 - 09	LS
SB6	1100	97 - 00	HF

**BREMBO RACING CALIPERS**  
Goldline 20.5161.42/51, road

**CAGIVA**

	50 Lucky Explorer	88 - 02	HF
	50 Prima	92 - 92	HF
	50 Super City	93 - 95	HF
	50 Supercity	92 - 92	HF
	50 W 4	92 - 92	HF
	80 Cocis	91 - 91	HF
	80 Super City	94 - 84	HF
	80 Supercity	92 - 93	HF
	80 W 4	92 - 92	HF
LR	80	83 - 83	HF
SST	80	83 - 83	HF
SXT	80	83 - 83	HF
	125 Aletta Electra	87 - 87	HF
	125 Aletta Oro	86 - 89	HF
	125 Blues	87 - 85	HF
	125 Blues	93 - 93	HF
	125 Cruiser	88 - 88	HF
	125 Dakar	86 - 86	HF
	125 Elefantre	87 - 88	HF
	125 Enduro	86 - 86	HF
	125 Freccia	89 - 89	HF
	125 Freccia C 12 R	91 - 91	HF
	125 Mito	91 - 07	HF
	125 Planet	97 - 07	HF
	125 Raptor	03 - 10	HF
	125 Supercity	92 - 00	HF
	125 W 8	92 - 95	HF
K7	125	91 - 94	HF

Brake Pad 1:1 Drawings, Compounds, Fitments

STREET HF • HS • LS  
 AMERICAN H.HF • H.CT • H.HS • H.LS  
 SCOOTER HF • CT • MS

RACING  
 OFF ROAD  
 ATV

RST • DC • DCC • DS-1 • DS-2 • RQ  
 SI • RSI • CS  
 ATS • SI • RSI • PSI

Drawings 1:1

Available compounds

HF

SBS 518

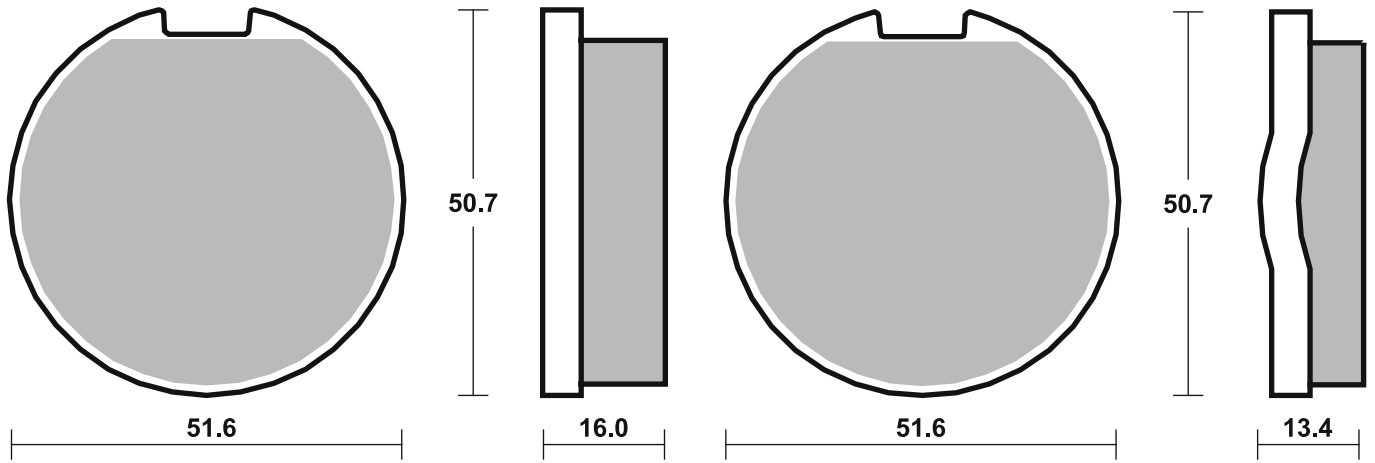

Available compounds

HF • LS • DCC • RQ • SI • RSI

SBS 519

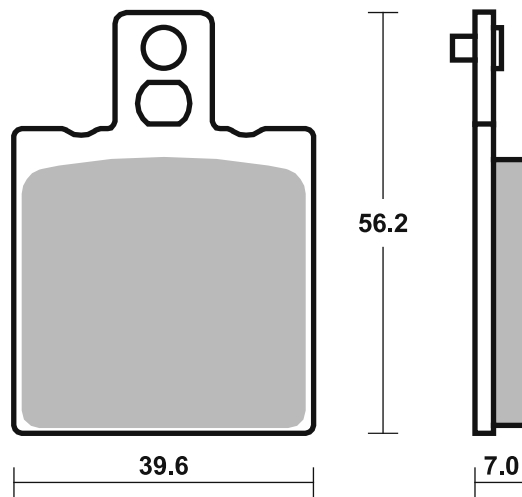



<b>CAGIVA</b>			
N1	125	96 - 99	HF
WMX	125 GP-Replica	86 - 89	SI
WRX	125	85 - 85	HF
	200 Elefant	86 - 86	HF
MXR	250	82 - 82	HF
SST	250 Ala Verde	81 - 82	HF
WMX	250 GP	82 - 82	SI
	350 Alazurra	85 - 87	HF HF
	350 Elefant	86 - 89	HF
	350 W 12	92 - 95	HF
SST	350	83 - 83	HF
SST	350 Ala Verde	81 - 82	HF
SXT	350 Ala Rosa	82 - 82	HF
T4	350 E	87 - 91	HF
T4	350 R	87 - 99	HF
MXR	400	82 - 82	HF
	500 Mito	07 - 07	LS
	500 River	00 - 01	HF
MXR	500	82 - 82	HF
T4	500 E	87 - 90	HF
WMX	500	85 - 86	SI
WMX	500 Cross	87 - 87	SI SI
SP	525 Mito	08 - 10	LS
	600 River	94 - 99	HF
	650 Alazurra	84 - 84	HF HF
	650 Elefant	86 - 87	HF
	750 Elefant	88 - 88	HF HF
	750 Lucky Explorer	88 - 88	HF

**CAN-AM**

	200 ASE	86 - 86	SI
	250 ASE	86 - 86	SI
	250 MX LC	86 - 86	SI
	350 ASE	86 - 86	SI
	406 ASE	87 - 87	SI
	500 ASE	86 - 86	SI
	500 MX	86 - 86	SI
	560 Sonic	86 - 14	SI

**DB MOTORS**

ZZ	50 Pirat	00 - 05	HF HF
ZZ	50 Sport	00 - 05	HF

**DERBI**

	125 Mulhacen	07 - 07	HF
	125 Terra	07 - 07	HF
	250 RC	85 - 85	HF

**DUCATI**

	350	75 - 78	HF
	350 GTV	77 - 77	HF HF
	350 Indiana	86 - 91	HF
	350 Paso	86 - 86	HF HF
	350 Sport	77 - 80	HF HF
	400 Monster (Japan)	01 - 06	LS
	400 SS, Junior	92 - 97	HF
	400 SS, Nuda	92 - 96	HF
	500 GTV	77 - 82	HF HF
	500 Pantah	85 - 89	HF HF
	500 Sport Desmo	77 - 82	HF
	500 Twin GTL	75 - 80	HF
	502 Single	93 - 93	HF
	502 Supermono	93 - 93	HF
	600 Monster	00 - 01	LS
	600 SL, TL Pantah	76 - 89	HF
	600 SS Supersport	95 - 00	HF
M	600 Monster	94 - 99	HF
	620 Monster Dark i.e.	02 - 06	LS
	620 Monster i.e., s i.e.	02 - 06	LS
	650 Indiana	86 - 89	HF



<b>DUCATI</b>			
	695 Monster	07 - 12	LS
	748 , S	99 - 02	LS
	748 Biposto	95 - 98	HF
	748 R	00 - 02	LS
	748 SP	95 - 97	HF
	748 SPS	98 - 99	LS
	750 Indiana	85 - 86	HF
	750 Monster	96 - 99	HF
	750 Monster	00 - 01	LS
	750 Monster i.e.	02 - 02	LS
	750 Paso	86 - 88	HF
	750 SS Supersport	95 - 99	HF
	750 SS, Carenara	92 - 88	HF
	750 SS, Nuda	92 - 92	HF
	750 Super Sport	92 - 94	HF
	800 Monster Dark		
	i.e., s i.e.	03 - 07	LS
	800 Monster i.e.,		
	s i.e.	03 - 07	LS
	803 Monster S2R	05 - 07	LS
	803 Monster S2R		
	ABS	05 - 07	LS
	851 Strada	89 - 89	HF
	851 Superbike	90 - 90	HF
	888 SP V	93 - 93	HF
	888 SP4	92 - 95	HF
	888 SPO	93 - 93	HF
	888 SPS	92 - 95	HF
	888 Strada	93 - 93	HF
	888 Superbike	93 - 93	HF
	900 FE	97 - 98	HF
	900 I. E.	90 - 93	HF
	900 M, IL Monster	93 - 99	HF
	900 Monster	00 - 01	LS
	900 Monster i.e.	02 - 02	LS
	900 Paso	89 - 89	HF
	900 SL	92 - 97	HF
	900 SS	90 - 94	HF
	900 SS Supersport	95 - 97	HF
	900 SSR	92 - 92	HF
M	900 Street Monster	94 - 99	HF
MH	900	00 - 01	LS
	916 Biposto	94 - 98	HF
	916 Monster S4	01 - 03	LS
	916 SPS	97 - 98	LS
	996	99 - 01	LS
	996 Monster S4R	04 - 06	LS
	996 R	01 - 01	LS
	996 RS		
	(slipper clutch)	00 - 01	LS
	996 S	01 - 01	LS
	998	02 - 04	LS
	998 R	02 - 04	LS
	998 RS		
	(slipper clutch)	02 - 03	LS
	998 S	02 - 04	LS
	1000 Monster Dark		
	i.e., s i.e.	03 - 06	LS
	1000 Monster i.e.,		
	s i.e.	03 - 06	LS

**FANTIC**

	50 Koala	88 - 89	HF HF
RC	50 Caballero	91 - 91	HF HF
RS	50 Caballero	91 - 91	HF HF
	250 Coach	91 - 98	HF

**GARELLI**

	50 Tiger XLE	86 - 86	HF HF
	50 Urka	91 - 91	HF



<b>GILERA</b>			
GTA	125	80 - 85	HF HF
GTA	125	83 - 85	HF
XR	125 Tiger XRD	85 - 85	HF
SP	01	90 - 90	HF
	50 Rally, R1	92 - 96	HF
	50 Sioux	92 - 92	HF HF
RC	50 Top Rally	90 - 90	HF HF
	125 Arizona Hawk	86 - 89	HF
	125 Crono	92 - 95	HF
	125 Freestyle	92 - 95	HF
	125 HX, HE	83 - 83	HF
	125 KK, KR, KZ	86 - 91	HF
	125 MX1, MRX, SP01	89 - 93	HF
	125 R1, R1S	90 - 92	HF
	125 SP02	90 - 94	HF
CX	125	91 - 95	HF
MXR	125	90 - 90	HF
RX	125	83 - 83	HF
XR2	125	90 - 90	HF
	200 Fast Bike	87 - 87	HF
	200 RX	83 - 83	HF
RV	200	85 - 86	HF
	250 Arizona Hawk	86 - 91	HF
	250 Arizona Rally	86 - 91	HF
	250 Arizona Rally	08 - 08	HF
NGR	250	85 - 85	HF
	350 Saturno Bialbero	90 - 90	HF
XRT	350	90 - 90	HF
	500 Saturno Bialbero	90 - 90	HF
	500 Saturno Piuma	90 - 94	HF
	600 Nordwest	91 - 94	HF
RC	600	88 - 88	HF
XRT	600	89 - 89	HF

**HERCULES**

ZX	125	86 - 86	HF
----	-----	---------	----

**HUSQVARNA**

CR	125	85 - 90	SI
CX	125	84 - 85	SI
	200 Prof	86 - 86	SI SI
CR	240	84 - 85	SI
CR	250	85 - 87	SI
CX	250	84 - 85	SI
	400 Enduro	85 - 88	SI
	430 Enduro	85 - 88	SI
CR	500	86 - 87	SI
CX/CR	500	84 - 85	SI
TC	500	86 - 86	SI
	504	83 - 83	SI
TE	510	86 - 87	SI

**ISR CALIPERS**

	2 Piston (22-027/028/029)		
	4 Piston (22-025)		

**ITALJET**

	350	83 - 83	HF
--	-----	---------	----

**KEEWAY**

	125 Enduro	07 - 08	HF
	125 X-Ray	07 - 08	HF

**KREIDLER**

	125 Mustang	83 - 87	HF
--	-------------	---------	----

**KTM**

GXE	50	87 - 88	HF
MX	50	87 - 90	SI
RSV	50	86 - 89	SI

STREET HF • HS • LS  
AMERICAN H.HF • H.CT • H.HS • H.LS  
SCOOTER HF • CT • MS

RACING  
OFF ROAD  
ATV

RST • DC • DCC • DS-1 • DS-2 • RQ  
SI • RSI • CS  
ATS • SI • RSI • PSI

Available compounds

HF • LS • DCC • RQ • SI • RSI

SBS 519

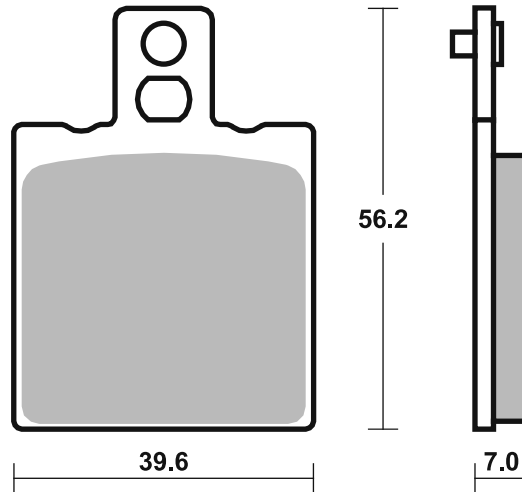



<b>KTM</b>			
	80 RSL, L, RS, RL	80 - 85	HF HF
PL	80	85 - 88	HF HF
RLW	80	80 - 81	SI SI
MX	85	90 - 90	SI
LC	125	85 - 85	SI
LC	125	86 - 86	SI SI
MX	125	85 - 85	SI
MX	125	86 - 86	SI SI
XC	125	85 - 85	SI
XC	125	86 - 89	SI SI
	250 Baja	86 - 89	SI
	250 Country,Baja	85 - 85	SI
LC	250	85 - 85	SI
LC	250	86 - 86	SI SI
MC	250	83 - 84	SI SI
MX	250	85 - 85	SI
XC	250	85 - 85	SI
XC	250	86 - 89	SI SI
XC	300	85 - 85	SI
XC	300	86 - 90	SI SI
	350 Country Cross	85 - 85	SI
	350 GS	83 - 85	SI
GS4	350 500 K4	82 - 83	SI
K4	350 500 K4	82 - 83	SI
XC	350 , MC	81 - 83	SI
	390 GS	83 - 83	SI
XC	390 , MC	81 - 83	SI
XC	420 , MC	81 - 83	SI
MC	495 Leleu	82 - 83	SI
MX	495 Leleu	82 - 83	SI
GS	500 500 K4 Enduro	83 - 83	SI
LC	500	85 - 85	SI
LC	500	86 - 89	SI SI
MX	500	85 - 85	SI
MX	500	86 - 86	SI SI
XC	500 , MC	81 - 83	SI
4T	600 Enduro	84 - 86	SI
GS	600	85 - 85	SI
XC	600 Cross	85 - 85	SI
XCE	600 Cross	85 - 85	SI
	620 Duke	96 - 98	HF
	640 Duke	99 - 02	HF
<b>LAVERDA</b>			
	50 Gaucho	92 - 92	HF HF
OR	50 Atlas	86 - 92	HF HF
	125 Custom	86 - 99	HF
CU	125 Ride	86 - 99	HF
LB	125 Uno	85 - 89	HF
GS	350 Lesmo	86 - 89	HF HF
PF	350 Alpino	77 - 83	HF HF
RS	350 Alpino	77 - 83	HF HF
	500 Alpino, S	77 - 83	HF HF
OR	600 Atlas	86 - 90	HF
	650	92 - 92	HF
	668 668	96 - 97	HF
	668 Ghost,		
	Diamante	97 - 97	HF
	750 Cup	98 - 01	HF
	750 Diamante	97 - 01	HF
	750 Ghost Strike	97 - 01	HF
	750 S Formula	97 - 01	HF
	750 S, S Carenata	97 - 01	HF
	750 Sport	99 - 01	HF
	750 Strike/		
	Black Strike	99 - 01	HF
	750 T8	98 - 01	HF
JOTA	1000	95 - 95	HF



<b>MAICO</b>			
GM	250 LC	85 - 85	SI
MD	250	83 - 85	SI SI
GM	500 LC	85 - 86	SI
<b>MALAGUTI</b>			
	50 Enduro	85 - 87	HF
MRX	50	89 - 89	HF
RST	50	90 - 90	HF HF
<b>MALANCA</b>			
	125 Mark	85 - 85	HF
<b>MONTESA</b>			
	260 Evasion	92 - 92	RSI
	309 Cota	89 - 90	RSI
	310 Cota	89 - 92	RSI
	311 Cota Trial	92 - 92	RSI
<b>MOTO-GUZZI</b>			
	125 Custom	85 - 85	HF
	125 Enduro TT	85 - 85	HF
BX	125	92 - 92	HF HF
	240 /4	77 - 77	HF
	250 TS	75 - 76	HF
	350	77 - 81	HF HF
	350 Falco	88 - 88	HF HF
	350 Imola	78 - 84	HF HF
	350 Nevada	92 - 97	HF
NTX	350	88 - 88	HF HF
NTX	350	90 - 90	HF
V35	350 C	82 - 86	HF
V35	350 Florida	85 - 86	HF
V35	350 GT	77 - 77	HF
V35	350 GT	90 - 90	HF
V35	350 II, Imola, Imola II	77 - 77	HF HF
	400	77 - 84	HF HF
	500	77 - 80	HF HF
	500 Monza	78 - 85	HF HF
V50	500 1,2,3, Monza		
	Chopper	77 - 77	HF HF
	650	80 - 84	HF HF
	650 Florida	85 - 84	HF HF
GT	650 Sessantacinque	89 - 89	HF HF
NTX	650	90 - 02	HF
V65	650 Lario	86 - 94	HF HF
V65	650 NTX	87 - 02	HF HF
V65	650 SP, Chopper	80 - 84	HF HF
V65	650 TT	86 - 94	HF HF
	750 Ippogrifo	97 - 97	HF
	750 Nevada	92 - 96	HF
	750 Nevada,		
	Club/Base	97 - 02	HF HF
	750 Targa	89 - 89	HF HF
NTX	750	89 - 89	HF HF
RS	1000 Daytona	97 - 00	HF
V	1000 Strada	93 - 94	HF
V10	1000 Centauro	96 - 00	HF
	1100 Sport	96 - 04	HF
EV	1100 California	97 - 00	HF
EV	1100 California, 80,		
	Touring	01 - 01	LS
V11	1100 , Scura,		
	Sport Scura	02 - 05	LS
V11	1100 Lemans,		
	Lemans Tenni,		
	Lemans Rosso		
	Corsa	01 - 06	LS
V11	1100 Sport	97 - 00	HF
V11	1100 Sport Rosso		
	Mandell	01 - 06	LS



<b>MOTO-GUZZI</b>			
V11	1100 Sport,		
	Sport Naked	01 - 05	LS
<b>MOTO-MORINI</b>			
XE	250 Country	88 - 88	HF
	350 Coguaro	90 - 95	HF
	350 Coguaro,		
	New York	90 - 94	HF
	350 Dart	88 - 88	HF
	350 Dart	90 - 92	HF
	350 Indiana	88 - 88	HF
	350 Kanguro	88 - 88	HF
RLX	350 Excalibur	90 - 92	HF
	400 Dart	89 - 92	HF
	400 S	82 - 82	HF HF
	500 Sei V Classic	89 - 89	HF
	501 Camel	88 - 88	HF
	501 Coguaro	89 - 89	HF
	501 New York	89 - 89	HF
RLX	501 Excalibur	88 - 90	HF
	650 Indiana	88 - 88	HF
	750 Indiana	88 - 88	HF
<b>MZ</b>			
	660 (MUZ)		
	Skorpion Cup	99 - 99	HF
	660 (MUZ)		
	Skorpion Replica	97 - 99	HF
	660 (MUZ)		
	Skorpion Sport	95 - 99	HF
	660 (MUZ)		
	Skorpion Tour	95 - 00	HF
	660 (MUZ)		
	Skorpion		
	Traveller	99 - 00	HF
<b>OSSA</b>			
	500 Yanqee	78 - 78	HF
<b>REWACO</b>			
	FX4	07 - 07	HF
	FX5	07 - 07	HF
	FX6	07 - 07	HF
	HS4	01 - 01	HF
	HS5	01 - 01	HF
	HS6	01 - 01	HF
	RF1	07 - 14	HF
<b>SACHS</b>			
SW	80 Lotus	82 - 82	HF
<b>SANGLAS</b>			
	400 Y	79 - 80	HF HF
	500 S2	79 - 80	HF HF
<b>SIMSON</b>			
	50 Habict CX	01 - 99	HF
	80 IFA	89 - 89	HF
SR	80 - 2 CE	87 - 87	HF
S	83 CX	93 - 93	HF
S	83 OR	83 - 83	HF
<b>SWM</b>			
	125 GP	86 - 86	HF HF
	125 S1-S2	83 - 83	HF
	250 Explorer	86 - 86	SI SI
	250 Pioner	86 - 86	SI SI
	250 S1-S2	83 - 83	HF
TRL	329 MJ	86 - 86	RSI



STREET HF • HS • LS  
AMERICAN H.HF • H.CT • H.HS • H.LS  
SCOOTER HF • CT • MS

RACING  
OFF ROAD  
ATV

RST • DC • DCC • DS-1 • DS-2 • RQ  
SI • RSI • CS  
ATS • SI • RSI • PSI

Available compounds

HF • LS • DCC • RQ • SI • RSI

SBS 519

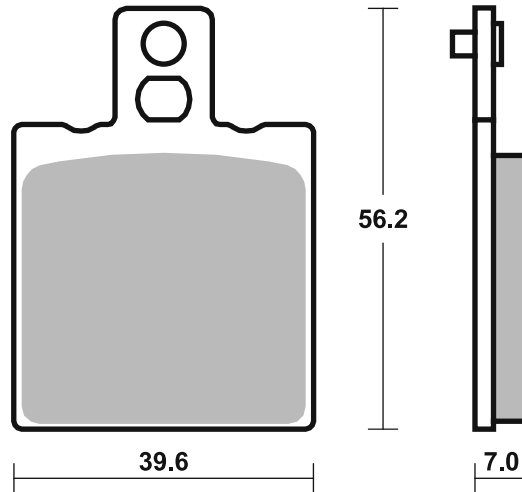



STREET HF • HS • LS  
 AMERICAN H.HF • H.CT • H.HS • H.LS  
 SCOOTER HF • CT • MS

RACING  
 OFF ROAD  
 ATV

RST • DC • DCC • DS-1 • DS-2 • RQ  
 SI • RSI • CS  
 ATS • SI • RSI • PSI

Drawings 1:1

Available compounds

HF • LS • DCC • RQ • SI • RSI

SBS 519

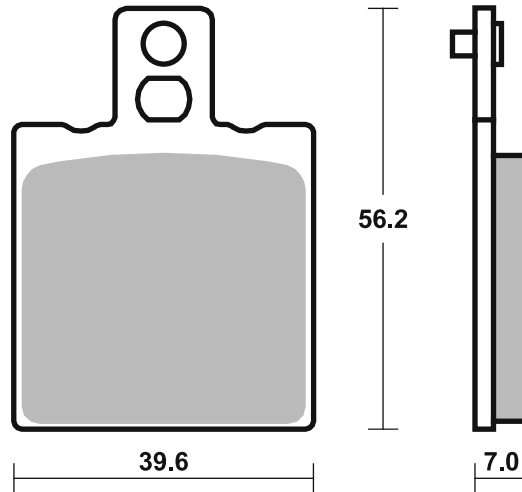

Available compounds

HF

SBS 520

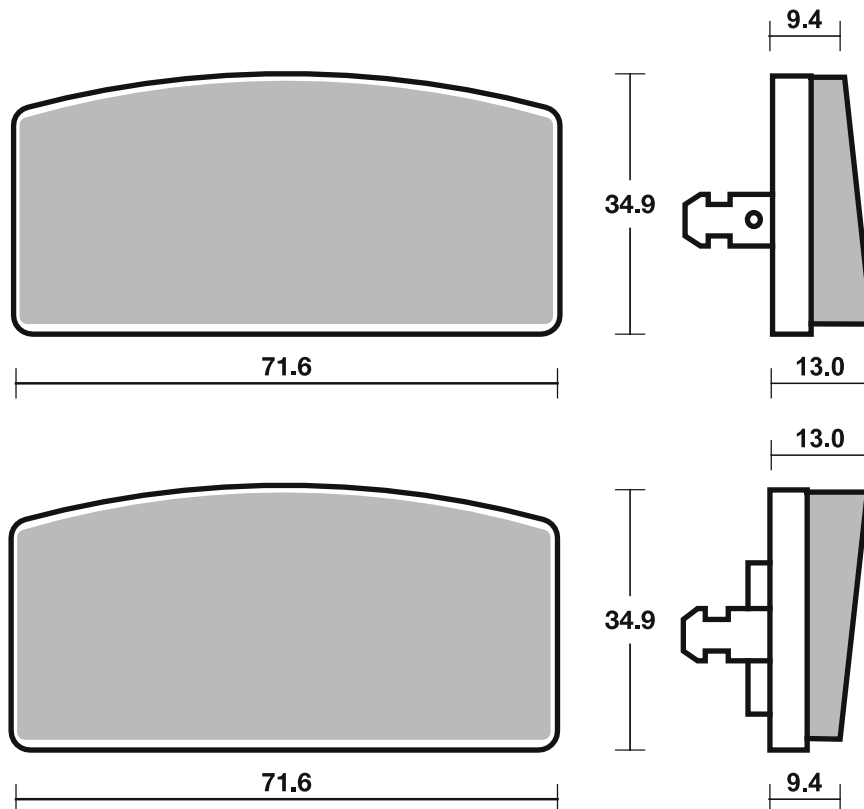

# Applications

## SBS 522

### Recommended compound



#### KAWASAKI

KH	90	78 - 83	HF	
KH	100 EX, G	81 - 82	HF	
Z	400	78 - 78	HF	

## SBS 523

### Recommended compound



#### A.P. RACING CALIPERS

CP-2696-36E0/38E0				
CP-3696-2E0				
CP-3697-2E0				
CP-4638-2E0				

#### DUCATI

750 Sport	74 - 76	HF		
-----------	---------	----	--	--

#### ISR CALIPERS

2 Piston (22-030/033)				
-----------------------	--	--	--	--

#### TRIUMPH

750 Trident T160V	75 - 77	HF	HF	
T140	750 D,E,F,			
	V Bonneville	76 - 81	HF	HF
T140	750 ES Bonneville	81 - 83	HF	HF
TR65	750 Thunderbird	81 - 83	HF	
TR7T	750 Tiger Trail	81 - 83	HF	



#### TRIUMPH

TR7V	750 Tiger	73 - 81	HF	HF
TSS	750	83 - 83	HF	HF
TSS	750 Electro Eight Valve	84 - 84	HF	
TSX	750	83 - 83	HF	HF

## SBS 524

### Recommended compound



#### HYOSUNG

125 Cruise II	99 - 06	HF		
125 Cruise II Classic	99 - 06	HF		
125 Cruiser	92 - 06	HF		
GA 125	98 - 06	HF		
GA 125 F	00 - 06	HF		
GF 125	98 - 04	HF		
GS 125	99 - 99	HF		
TN 125	92 - 95	HF		

#### KREIDLER

50 Florett	81 - 82	HF		
------------	---------	----	--	--

#### SUZUKI

GP	125 all models	77 - 84	HF	
----	----------------	---------	----	--

Brake Pad 1:1 Drawings, Compounds, Fitments

STREET HF • HS • LS  
 AMERICAN H.HF • H.CT • H.HS • H.LS  
 SCOOTER HF • CT • MS

RACING  
 OFF ROAD  
 ATV

RST • DC • DCC • DS-1 • DS-2 • RQ  
 SI • RSI • CS  
 ATS • SI • RSI • PSI

Drawings 1:1

Available compounds HF

SBS 522

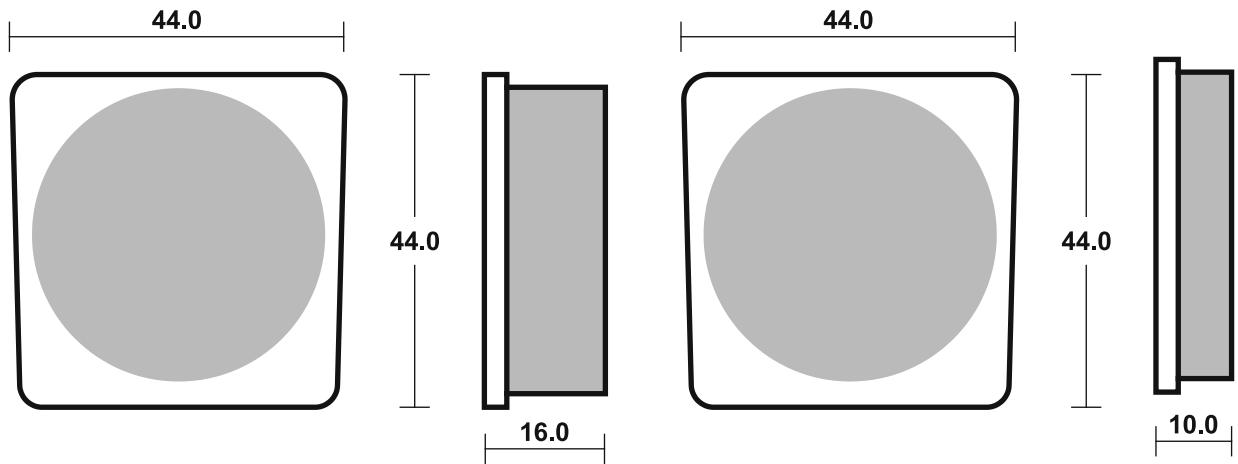

Available compounds HF • DC • DCC

SBS 523

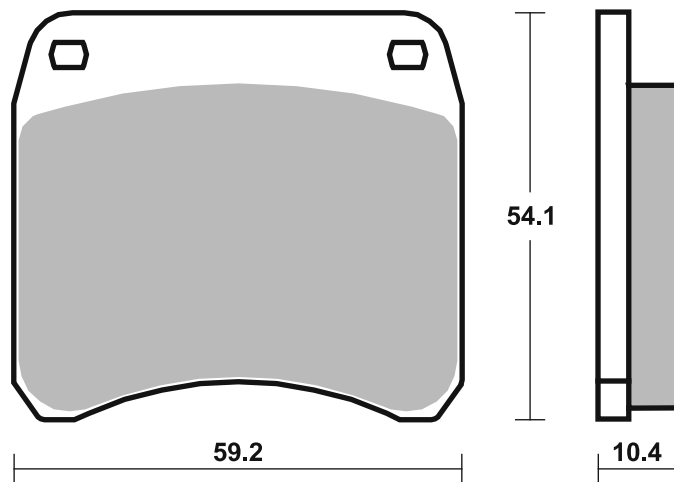

Available compounds HF

SBS 524

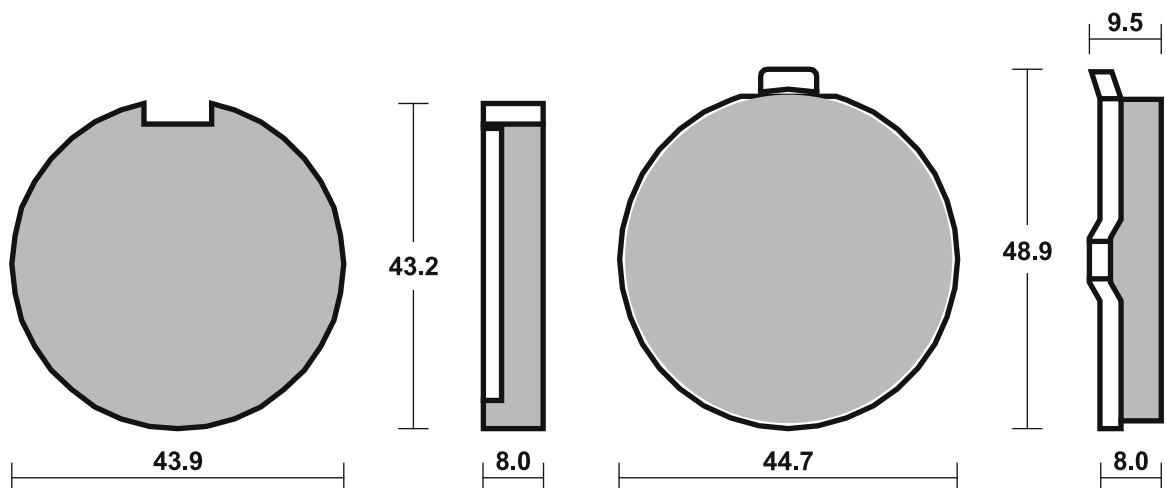

**SBS 525**

**Recommended compound**



<b>HONDA</b>			
CB	50 J, K1	75 - 79	<b>HF</b>
SS	50 ZB2	75 - 80	<b>HF</b>
CB	90	79 - 84	<b>HF</b>
CG	110	77 - 79	<b>HF</b>
CB	125 J	79 - 79	<b>HF</b>
CB	125 S	76 - 78	<b>HF</b>
MT	125 R	77 - 77	<b>HF</b>
FL	250 Odyssey	77 - 84	<b>HF</b>

**SBS 526**

**Recommended compound**



<b>HONDA</b>			
CB	250 N	78 - 81	<b>HF</b>
CB	250 NA, NB, T, TZ	77 - 81	<b>HF</b>
CB	250 RS	80 - 84	<b>HF</b>
CM	250 TB	81 - 81	<b>HF</b>
CB	400 A	77 - 81	<b>HF</b>
CB	400 N, T, Hawk	78 - 82	<b>HF</b>
CB	400 T1, T2	77 - 78	<b>HF</b>
CM	400 A, T, TZ	79 - 79	<b>HF</b>
CM	400 T	79 - 81	<b>HF</b>
CB	650	79 - 81	<b>HF</b>
CB	650 C	80 - 85	<b>HF</b>
CB	650 Z	78 - 81	<b>HF</b>
CB	750 C	80 - 81	<b>HF</b>
CB	750 K, L	79 - 80	<b>HF</b>
CB	750 PZ	81 - 84	<b>HF</b>

**SBS 527**

**Recommended compound**



<b>BMW</b>			
R45	450	78 - 85	<b>HF</b>
R65	650	78 - 79	<b>HF</b>

STREET HF • HS • LS  
 AMERICAN H.HF • H.CT • H.HS • H.LS  
 SCOOTER HF • CT • MS

RACING  
 OFF ROAD  
 ATV

RST • DC • DCC • DS-1 • DS-2 • RQ  
 SI • RSI • CS  
 ATS • SI • RSI • PSI

Drawings 1:1

Available compounds HF

SBS 525

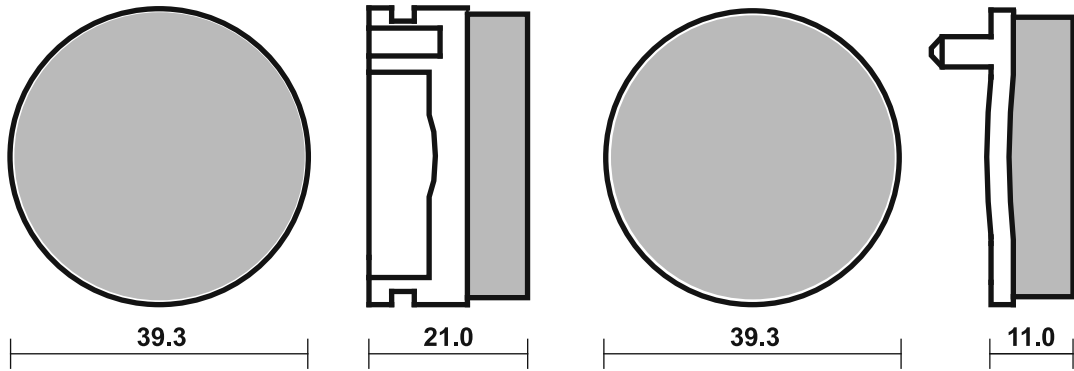

Available compounds

HF • DCC

SBS 526

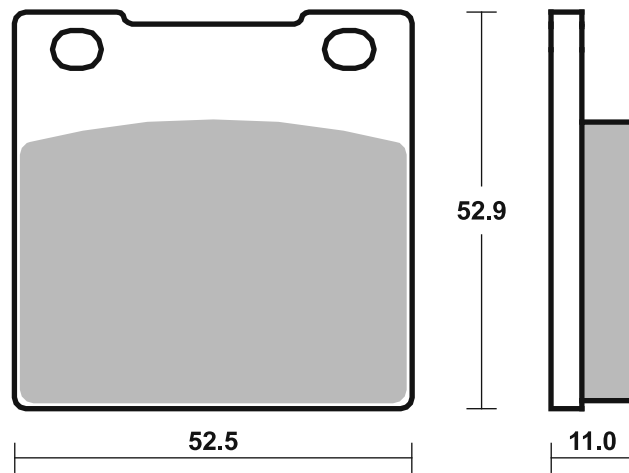

Available compounds

HF

SBS 527

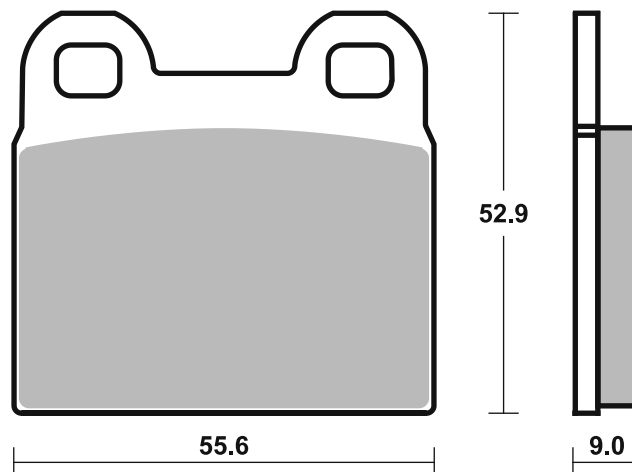

Brake Pad 1:1 Drawings,  
 Compounds, Fitments

Applications

SBS 528

Recommended compound



<b>YAMAHA</b>			
GX	250	80 - 85	<b>HF</b>
RD	250	78 - 79	<b>HF HF</b>
RD	250 DX	80 - 80	<b>HF</b>
XS	250 SE, SF	80 - 81	<b>HF</b>
RD	400	78 - 78	<b>HF HF</b>
RD	400	79 - 79	<b>HF</b>
XS	400 SE	80 - 81	<b>HF</b>
XS	400 SG, SH, SF	80 - 81	<b>HF</b>
XJ	650 G, H, SH	80 - 83	<b>HF</b>
XS	750 SE	79 - 80	<b>HF</b>
XV	750 MK	83 - 83	<b>HF</b>
XS	850	81 - 81	<b>HF</b>
XJ	1100	81 - 81	<b>HF HF</b>
XS	1100 LH Midnight	81 - 81	<b>HF HF</b>
XS	1100 SF, SG, SH, LG	79 - 81	<b>HF</b>

SBS 530

Recommended compound



<b>KAWASAKI</b>			
Z	1300	79 - 81	<b>HF</b>
Z	1300 DF1	84 - 84	<b>HF</b>

Brake Pad 1:1 Drawings, Compounds, Fittings



STREET HF • HS • LS  
 AMERICAN H.HF • H.CT • H.HS • H.LS  
 SCOOTER HF • CT • MS

RACING  
 OFF ROAD  
 ATV

RST • DC • DCC • DS-1 • DS-2 • RQ  
 SI • RSI • CS  
 ATS • SI • RSI • PSI

Drawings 1:1

Available compounds

HF

SBS 528

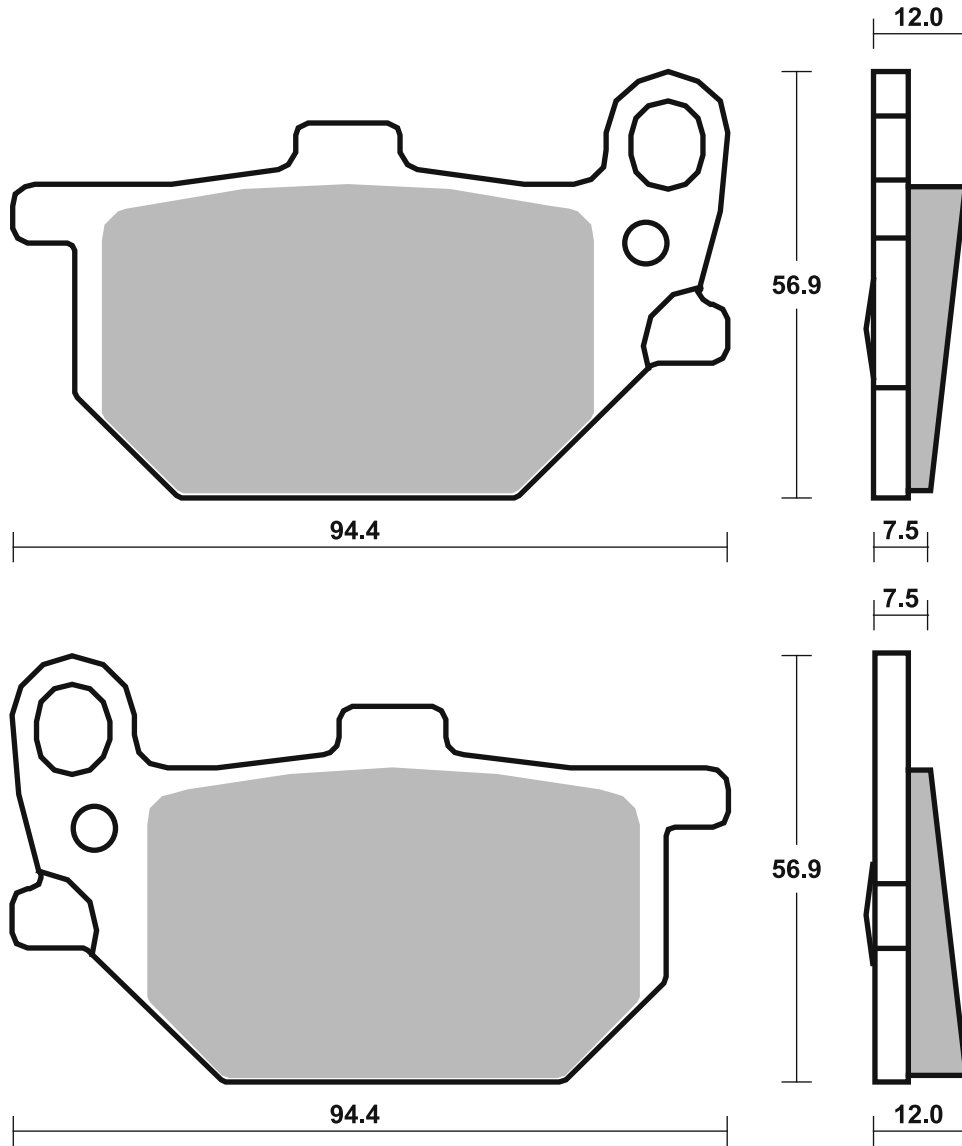

Available compounds

HF

SBS 530

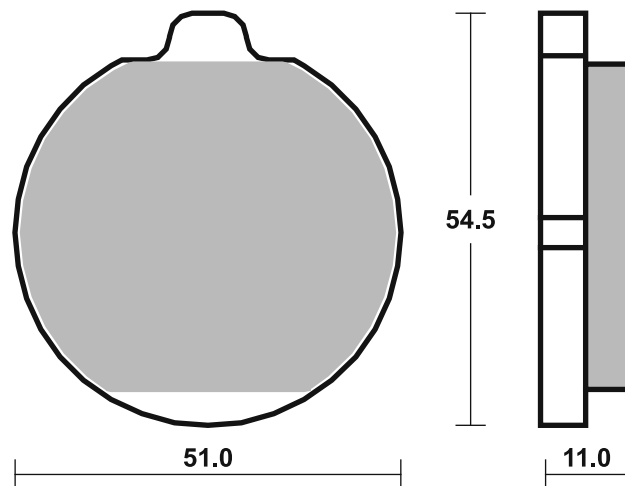

Dimensions in mm / Dimensions en mm  
 1" = 25.4 mm , 1 mm = 0.04"

Brake Pad 1:1 Drawings,  
 Compounds, Fitments

## Applications

### SBS 531

#### Recommended compound



#### YAMAHA

FS1	50 DX	79 - 81	HF
RD	50 M	79 - 80	HF
RD	100	80 - 82	HF
RS	100 DX	80 - 82	HF
RD	125 DX	78 - 81	HF
RS	125 DX	80 - 86	HF
RD	200 DX	78 - 81	HF

### SBS 532

#### Recommended compound



#### BENELLI

	254	83 - 83	HF
--	-----	---------	----

#### BETA

	50 Squirrel	83 - 83	HF
MG	125	83 - 83	HF

#### CASAL

RZ	50	82 - 82	HF
----	----	---------	----

#### CIMATTI

	50 Gringo	85 - 85	HF
--	-----------	---------	----

#### FANTIC

	50 Super SIX	83 - 83	HF
--	--------------	---------	----

#### GARELLI

	50 S, Sport	80 - 80	HF
	80 Sport	83 - 83	HF

#### HERCULES

	50 Ultra	79 - 83	HF
RS	50	79 - 83	HF
	80 Ultra AC	81 - 81	HF
	80 Ultra AC Ch.	81 - 83	HF
	80 Ultra Chopper	81 - 83	HF
RX-9	80	82 - 83	HF
RX-9	80 Aircooled	82 - 83	HF
KX-5	125	87 - 87	HF

#### HOREX

	80 Rebell N	83 - 83	HF
--	-------------	---------	----

#### MALAGUTI

	50 Chopper 25,		
	40, 80, Fifty	83 - 83	HF
	50 Chopper HF,		
	Watercooled	83 - 83	HF
RCW	50 Ronco	83 - 83	HF
V4	50 Olympique	83 - 83	HF
XL	50 Sport	83 - 85	HF
	125 Runner	86 - 86	HF



#### MALANCA

	125 Enduro Mark		
	ST 54, GT55	79 - 83	HF

#### MOTRON

GL4	50 ID Flash	92 - 92	HF
GTD	50 Italian Max, 2	92 - 92	HF
RZ1	50 Compact	92 - 92	HF

#### OSSA

	350 TU-YO	82 - 82	HF
--	-----------	---------	----

#### PUCH

	50 all models	86 - 86	HF
	50 Cobra 6 GT, GTL	80 - 84	HF
	50 Monza 4 SL, GSL	80 - 83	HF

#### REAL

	80 Nevada Sport	00 - 00	HF
--	-----------------	---------	----

#### RIXE

RS	80 W	82 - 82	HF
----	------	---------	----

#### SACHS

SA	80 Lotus	80 - 81	HF
----	----------	---------	----

#### ZUNDAPP

KS	50 Supersport	76 - 79	HF
KS	50 TT Watercooled	80 - 81	HF
KS	80	80 - 80	HF
KS	80 Touring	81 - 81	HF

#### ZWEIRAD ROTH

	50 Rebell Sport	75 - 75	HF
	80 Rebell Sport	75 - 75	HF

STREET HF • HS • LS  
AMERICAN H.HF • H.CT • H.HS • H.LS  
SCOOTER HF • CT • MS

RACING  
OFF ROAD  
ATV

RST • DC • DCC • DS-1 • DS-2 • RQ  
SI • RSI • CS  
ATS • SI • RSI • PSI

Drawings 1:1

Available compounds HF

SBS 531

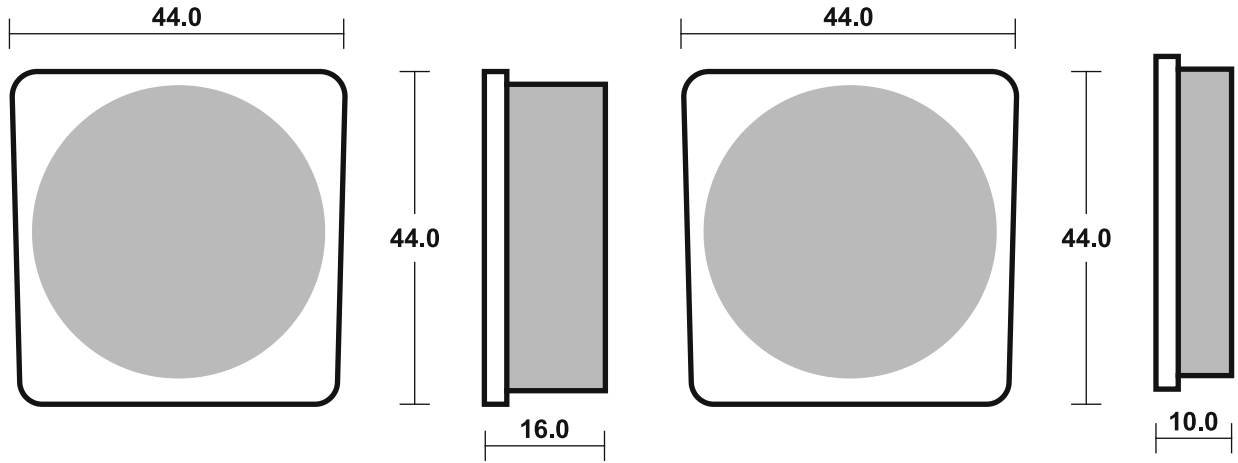

Available compounds HF

SBS 532

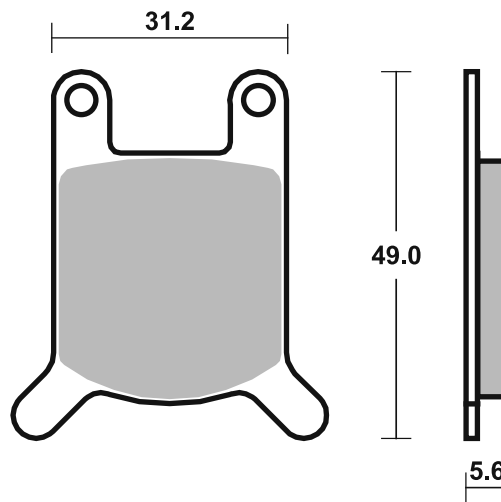

Applications

**SBS 533** Recommended compound



SUZUKI			
GN	250	86 - 97	HF
GNX	250	82 - 84	HF
GS	250	80 - 82	HF
GSX	250	80 - 82	HF
GN	400	80 - 80	HF
GSX	400	81 - 83	HF
GSX	400 F	81 - 84	HF
GS	450	80 - 83	HF
GS	700	85 - 85	HF
GV	700 GLG Madura	86 - 86	HF
GSX	750 E	82 - 83	HF
GSX	750 EF	80 - 86	HF
GSX	750 ES	83 - 85	HF
GSX	750 L	80 - 82	HF
GSX	750 S	82 - 82	HF
GS	850	81 - 82	HF
GS	850 G	83 - 86	HF
GSX	850 G	83 - 85	HF



SUZUKI			
GS	1000	80 - 81	HF
GS	1100	82 - 83	HF
GV	1200 GLG Madura	86 - 86	HF

**SBS 534** Recommended compound



SUZUKI			
GSX	250	85 - 87	HF
GSX	400 E, S	85 - 86	HF
GSX	400 FWS	86 - 87	HF
GS	450	85 - 85	HF
GS	500	82 - 85	HF
GS	500 E (Austria)	81 - 82	HF
GS	550	80 - 82	HF
GR	650	83 - 84	HF
GR	650 X	83 - 84	HF
GS	650	81 - 83	HF
GS	650 G	83 - 87	HF
GS	650 Turbo, XN	83 - 85	HF
GSX	650 GT	86 - 86	HF
GS	750 SD	83 - 83	HF
GSX	750 ES, EF, STS	86 - 88	HF
GSX	750 S, Katana	85 - 86	HF
XN	850	83 - 85	HF
G	1000 SZ	82 - 82	HF



SUZUKI			
GS	1000 ET	81 - 81	HF
GS	1000 EX	81 - 81	HF
GSX	1000 S, Katana	82 - 84	HF
GS	1100	81 - 81	HF
GS	1100 ED, ESD, GD	83 - 83	HF
GS	1100 G	86 - 88	HF
GS	1100 GKD, SD, GLD	83 - 83	HF
GS	1100 L	79 - 79	HF
GSX	1100	86 - 86	HF
GSX	1100 E	82 - 84	HF
GSX	1100 E, L	79 - 81	HF
GSX	1100 S	82 - 83	HF
GT	1100	80 - 80	HF
GV	1400 Cavalcade	85 - 86	HF

**SBS 535** Recommended compound



YAMAHA			
RD	250 LC	80 - 80	HF
RD	350 LC	80 - 80	HF
XJ	400	80 - 81	HF

Brake Pad 1:1 Drawings, Compounds, Fitments

STREET HF • HS • LS  
 AMERICAN H.HF • H.CT • H.HS • H.LS  
 SCOOTER HF • CT • MS

RACING  
 OFF ROAD  
 ATV

RST • DC • DCC • DS-1 • DS-2 • RQ  
 SI • RSI • CS  
 ATS • SI • RSI • PSI

Available compounds

HF

SBS 533

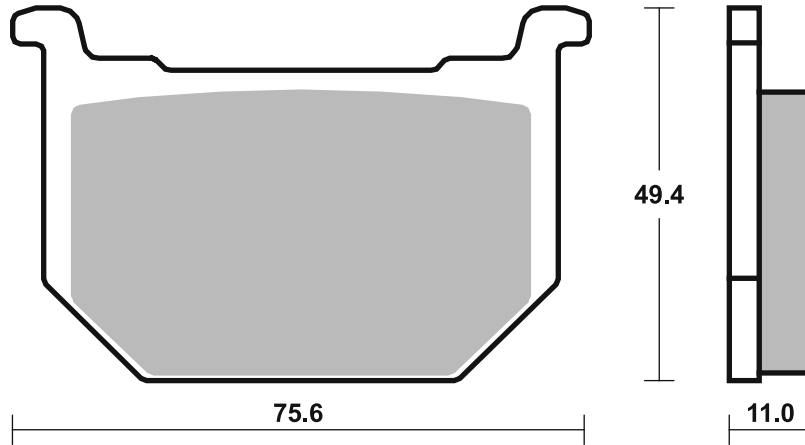

Available compounds

HF • DCC

SBS 534

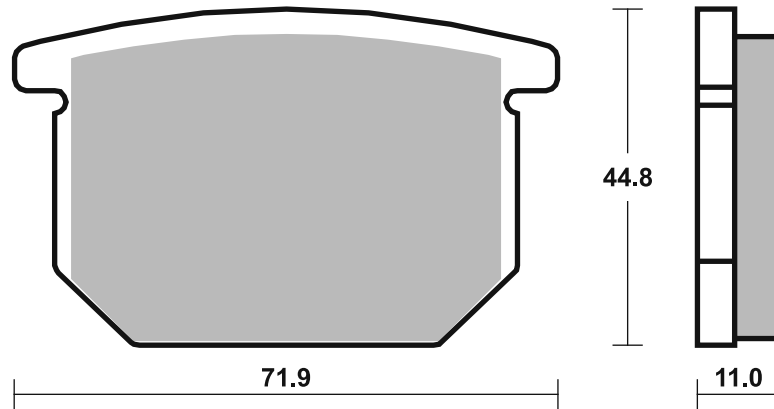

Available compounds

HF

SBS 535

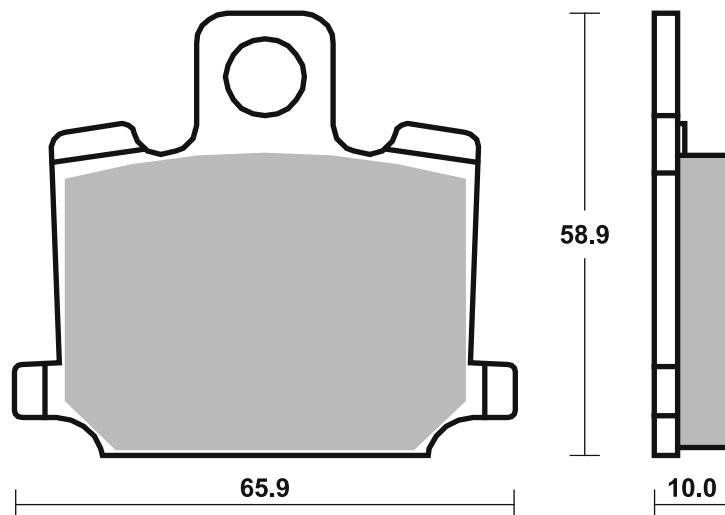

## Applications

### SBS 536

### Recommended compound



<b>DAELIM</b>			
100 Altino	99 -03	<b>HF</b>	
NF 125	03 -03	<b>HF</b>	
VS 125 , Evolution	95 -08	<b>HF</b>	

<b>HONDA</b>			
MBX 80 FWD	83 -86	<b>HF</b>	
CB 125 RS	83 -83	<b>HF</b>	
CG 125	04 -08	<b>HF</b>	
CG 150	04 -05	<b>HF</b>	
ATC 250 R	81 -81	<b>SI</b>	

<b>HUSQVARNA</b>			
all models CR, TC,TE,WR	92 -94	<b>SI</b>	

<b>HYOSUNG</b>			
TE 400	05 -06	<b>SI</b>	
TE 450	07 -11	<b>SI</b>	

<b>KAWASAKI</b>			
KX 65	00 -24	<b>RSI</b>	
BN 125 Eliminator	98 -99	<b>HF</b>	
KLX 125	10 -14	<b>HF</b>	
KLX 125 D-Tracker	10 -14	<b>HF</b>	
Z 125 Pro	17 -22	<b>HF</b>	
KLX 150 D-Tracker	16 -18	<b>HF</b>	
KLX 150 L	14 -15	<b>HF</b>	
KLX 230	19 -22	<b>HF</b>	
KLX 230 R	22 -23	<b>HF</b>	
KLX 230 SE	22 -22	<b>HF</b>	
KVF 360 Prairie 2x4, 4x4	03 -08	<b>SI</b>	
KVF 400 Prairie	97 -98	<b>SI</b>	
KVF 400 Prairie 2x4	99 -01	<b>SI</b>	
KVF 400 Prairie 4x4	99 -02	<b>SI</b>	

<b>MASH</b>			
125 Cafe Racer	14 -16	<b>HF</b>	
125 Seventy Five	14 -17	<b>HF</b>	
250 Cafe Racer	14 -16	<b>HF</b>	
250 Two Fifty	14 -17	<b>HF</b>	



<b>PGO</b>			
50 Bugrider	06 -06	<b>HF</b>	
BR 150 Bugxter	05 -07	<b>HF</b>	

<b>SUZUKI</b>			
RM 65	03 -06	<b>RSI</b>	
DR 125	86 -02	<b>HF</b>	
GX 125 R	88 -03	<b>HF</b>	
RH 125 X	87 -87	<b>HF</b>	
SP 125	86 -88	<b>HF</b>	
SX 125	85 -86	<b>HF</b>	
TS 125	85 -86	<b>HF</b>	
DR 200	86 -88	<b>SI</b>	
DR 200 S	15 -17	<b>SI</b>	
DR 200 SE	96 -13	<b>SI</b>	
DR 200 T	96 -96	<b>SI</b>	
SP 200	86 -88	<b>HF</b>	
SX 200 R	85 -89	<b>HF</b>	
RH 240 X	87 -87	<b>HF</b>	
TS 240 X	85 -90	<b>HF</b>	
DR 250	85 -89	<b>HF</b>	
LT-F 250 Ozark	03 -13	<b>SI</b>	
LT-Z 250 Quad Sport	04 -11	<b>SI</b>	
RH 250	85 -87	<b>HF</b>	
SP 250	85 -85	<b>HF</b>	
TS 250 X	85 -89	<b>HF</b>	
LT-A 400 Eiger 2WD/4WD	02 -07	<b>SI</b>	
LT-F 400 Eiger 2WD/4WD	02 -07	<b>SI</b>	
LT-A 500 F Vinson	02 -02	<b>SI</b>	

<b>YAMAHA</b>			
SX 125 R	88 -88	<b>HF</b>	
SX 200 R	88 -98	<b>HF</b>	
YFS 200 R Blaster	03 -06	<b>SI</b>	
YFM 250 AN Bruin 2x4	05 -07	<b>SI</b>	
YFM 250 Bear Tracker	01 -04	<b>SI</b>	
YFM 300 Warrior	89 -89	<b>SI</b>	
YFM 350 Bruin 2x4, 4x4	04 -07	<b>SI</b>	
YFM 350 FWB L, LC Big Bear	99 -99	<b>SI</b>	
YFM 350 FXG-FXM Wolverine	95 -11	<b>SI</b>	
YFM 350 XG,XH Warrior	95 -96	<b>SI</b>	



<b>YAMAHA</b>			
YFM 350 XW, XA-M Warrior	89 -07	<b>SI</b>	<b>SI</b>
YFZ 350 Banshee	90 -06	<b>SI</b>	
YFM 400 FAM Kodiak	00 -02	<b>SI</b>	
YFM 400 FAR Kodiak Automatic	03 -03	<b>SI</b>	
YFM 400 FWN Big Bear 4WD	00 -11	<b>SI</b>	
YFM 400 FWNH Big Bear-Buckmaster 4WD	00 -11	<b>SI</b>	
YFM 400 N Big Bear 2WD	00 -11	<b>SI</b>	
YFM 450 FA Kodiak	03 -07	<b>SI</b>	
YFM 450 Wolverine	06 -10	<b>SI</b>	

### SBS 537

### Recommended compound



<b>HARLEY DAVIDSON</b>			
XLH 883	70 -83	<b>H.HF</b>	
XL 1000	78 -78	<b>H.HF</b>	
XLCH 1000	78 -80	<b>H.HF</b>	
XLH 1000 Sportster	79 -85	<b>H.HF</b>	
XLS 1000 Anniversary	82 -82	<b>H.HF</b>	
XLS 1000 Roadster	79 -82	<b>H.HF</b>	
XLS 1000 Sportster	83 -83	<b>H.HF</b>	
XLX 1000 61	83 -84	<b>H.HF</b>	
XR 1000	85 -85	<b>H.HF</b>	
FX 1200	74 -80	<b>H.HF</b>	
FXE 1200	74 -80	<b>H.HF</b>	
FXS 1200	78 -79	<b>H.HF</b>	
FLHT 1340 Tour Glide	84 -84	<b>H.HF</b>	
FXB 1340 80	80 -81	<b>H.HF</b>	
FXB 1340 Sturgis	82 -82	<b>H.HF</b>	
FXE 1340	82 -82	<b>H.HF</b>	
FXE 1340 80	78 -81	<b>H.HF</b>	
FXE 1340 Super Glide	83 -84	<b>H.HF</b>	
FXEF 1340 80 Fat Bob	79 -81	<b>H.HF</b>	
FXR 1340	78 -81	<b>H.HF</b>	



<b>HARLEY DAVIDSON</b>			
FXR 1340 Super Glide	82 -83	<b>H.HF</b>	
FXRS 1340 Low Glide	82 -84	<b>H.HF</b>	
FXRS 1340 Super Glide II	82 -83	<b>H.HF</b>	
FXRT 1340 Super Glide II	83 -83	<b>H.HF</b>	
FXS 1340 80	79 -81	<b>H.HF</b>	
FXS 1340 Low Rider	82 -82	<b>H.HF</b>	
FXSB 1340 Low Rider	83 -83	<b>H.HF</b>	
FXWG 1340 80	80 -81	<b>H.HF</b>	
FXWG 1340 Wide Glide	82 -84	<b>H.HF</b>	

STREET HF • HS • LS  
 AMERICAN H.HF • H.CT • H.HS • H.LS  
 SCOOTER HF • CT • MS

RACING  
 OFF ROAD  
 ATV

RST • DC • DCC • DS-1 • DS-2 • RQ  
 SI • RSI • CS  
 ATS • SI • RSI • PSI

Drawings 1:1

Available compounds

HF • SI • RSI

SBS 536

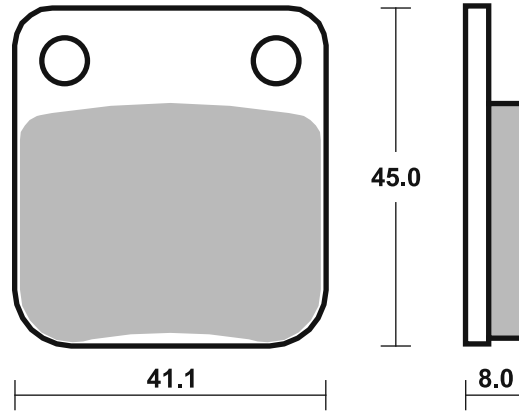

Available compounds

H.HF • H.CT

SBS 537

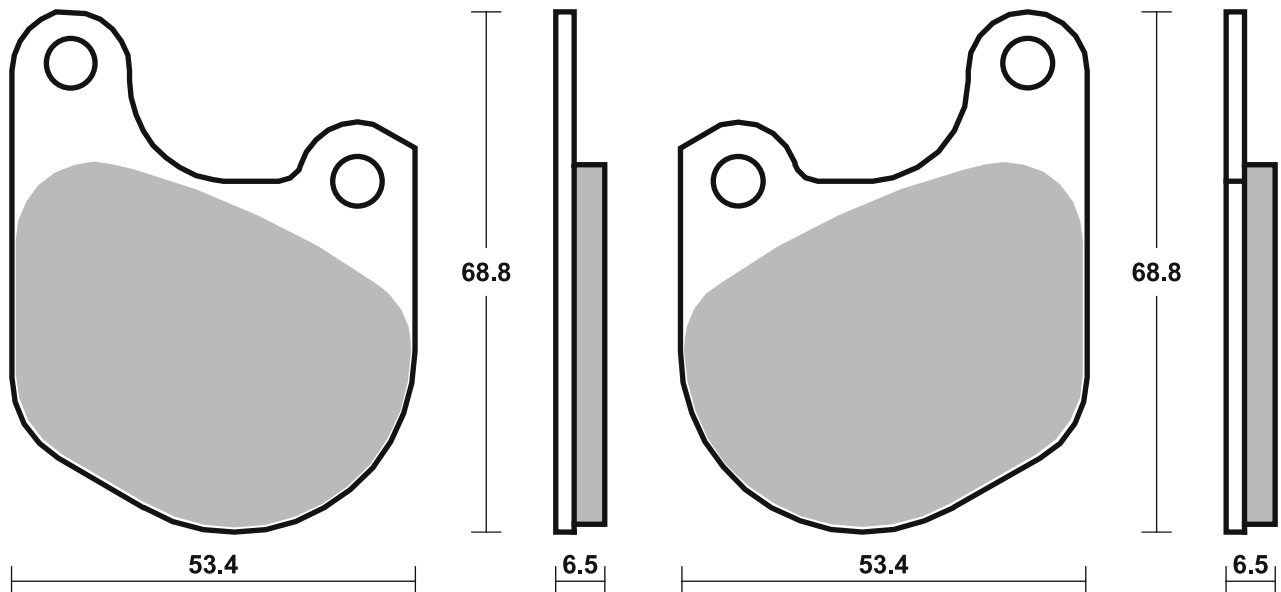

Dimensions in mm / Dimensions en mm  
 1" = 25.4 mm, 1 mm = 0.04"

Brake Pad 1:1 Drawings,  
 Compounds, Fitments

## Applications

### SBS 538

#### Recommended compound



<b>SUZUKI</b>			
GP	100	78 - 92	<b>HF</b>
GP	125 C (Norway)	78 - 78	<b>HF</b>

### SBS 539

#### Recommended compound



<b>KAWASAKI</b>			
GPZ	400	83 - 84	<b>HF</b>
Z	400 J	80 - 85	<b>HF</b>
Z	400 T (Belt Drive)	83 - 85	<b>HF</b>
Z	440 H	82 - 83	<b>HF</b>
Z	500	81 - 83	<b>HF</b>
Z	550 E, LTD	81 - 84	<b>HF</b>
Z	550 GP	81 - 83	<b>HF</b>
Z	550 LTD	81 - 85	<b>HF</b>
Z	650	81 - 84	<b>HF</b>
Z	650 F	81 - 84	<b>HF</b>
Z	700	83 - 88	<b>HF</b>
GPZ	750	82 - 82	<b>HF</b>
Z	750	84 - 86	<b>HF</b>
Z	750 E	80 - 81	<b>HF</b>
Z	750 GT	82 - 85	<b>HF</b>
Z	750 L	80 - 83	<b>HF</b>



<b>KAWASAKI</b>			
Z	750 LTD	81 - 81	<b>HF</b>
Z	750 LTD Belt Drive	83 - 85	<b>HF</b>
Z	750 LTD Twin	82 - 82	<b>HF</b>
Z	750 N, LTD	82 - 85	<b>HF</b>
Z	750 Sp.	83 - 84	<b>HF</b>
Z	1000 F1	80 - 82	<b>HF</b>
Z	1000 J	79 - 83	<b>HF</b>
Z	1000 K, M, CSR	81 - 84	<b>HF</b>
Z	1000 LTD	81 - 84	<b>HF</b>
Z	1000 MKII	79 - 80	<b>HF</b>
Z	1000 Police	82 - 84	<b>HF</b>
Z	1000 ST	79 - 81	<b>HF</b>
GPZ	1100	81 - 82	<b>HF</b>
Z	1100 GP	81 - 81	<b>HF</b>
Z	1100 L1, LTD	83 - 83	<b>HF</b>
Z	1100 Spectre	82 - 83	<b>HF</b>



<b>KAWASAKI</b>			
Z	1100 ST	81 - 83	<b>HF</b>
Z	1300 , Sports	79 - 83	<b>HF</b>

### SBS 540

#### Recommended compound



<b>KAWASAKI</b>			
Z	250 J	81 - 85	<b>HF</b>
Z	305	81 - 82	<b>HF</b>
Z	305	87 - 88	<b>HF</b>
GPZ	400	83 - 84	<b>HF</b>
Z	440 C, Twin	81 - 83	<b>HF</b>
Z	440 H	82 - 83	<b>HF</b>
Z	440 LTD	83 - 84	<b>HF</b>
Z	500	81 - 83	<b>HF</b>
Z	550	81 - 84	<b>HF</b>
Z	550 C3, LTD	82 - 84	<b>HF</b>
Z	550 E, LTD	81 - 84	<b>HF</b>
Z	550 GP	81 - 83	<b>HF</b>
Z	550 GT, LTD	82 - 85	<b>HF</b>
Z	550 M1, LTD	83 - 86	<b>HF</b>
Z	650 CSR	81 - 82	<b>HF</b>
Z	700	83 - 88	<b>HF</b>
GPZ	750	82 - 82	<b>HF</b>
Z	750	84 - 86	<b>HF</b>



<b>KAWASAKI</b>			
Z	750 E	80 - 81	<b>HF</b>
Z	750 GT	82 - 85	<b>HF</b>
Z	750 L	80 - 87	<b>HF</b>
Z	750 L	84 - 87	<b>HF</b>
Z	750 LTD	81 - 81	<b>HF</b>
Z	750 LTD Belt Drive	83 - 85	<b>HF</b>
Z	750 LTD Twin	82 - 82	<b>HF</b>
Z	750 M1	82 - 85	<b>HF</b>
Z	750 N, LTD	82 - 85	<b>HF</b>
Z	750 R1	82 - 82	<b>HF</b>
Z	750 Sp.	83 - 84	<b>HF</b>
Z	1000 J	79 - 83	<b>HF</b>
Z	1000 K, M, CSR	81 - 84	<b>HF</b>
Z	1000 LTD	81 - 84	<b>HF</b>
Z	1000 Police	82 - 84	<b>HF</b>
Z	1000 RE1, R2	82 - 84	<b>HF</b>
GPZ	1100	81 - 82	<b>HF</b>
Z	1100 GP	81 - 82	<b>HF</b>



<b>KAWASAKI</b>			
Z	1100 GP	82 - 82	<b>HF</b>
Z	1100 L1, LTD	83 - 83	<b>HF</b>
Z	1100 Spectre	82 - 83	<b>HF</b>
Z	1300 , Sports	79 - 83	<b>HF</b>



STREET HF • HS • LS  
 AMERICAN H.HF • H.CT • H.HS • H.LS  
 SCOOTER HF • CT • MS

RACING  
 OFF ROAD  
 ATV

RST • DC • DCC • DS-1 • DS-2 • RQ  
 SI • RSI • CS  
 ATS • SI • RSI • PSI

Drawings 1:1

Available compounds

HF

SBS 538

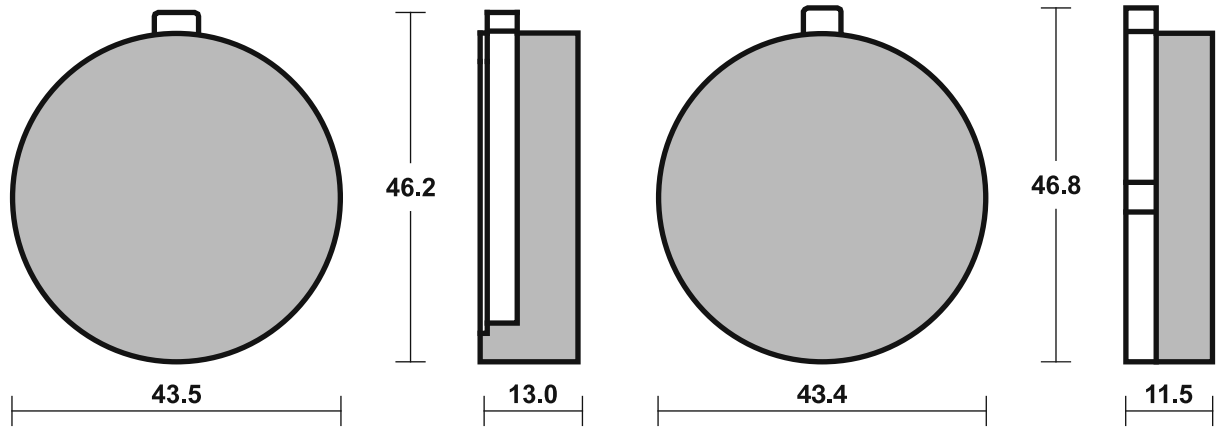

Available compounds

HF • DCC

SBS 539

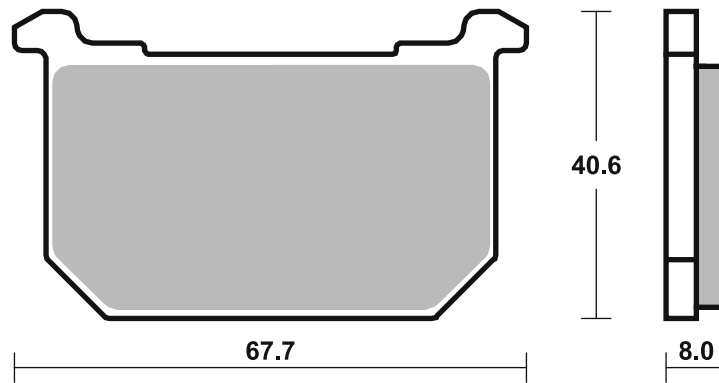

Available compounds

HF

SBS 540

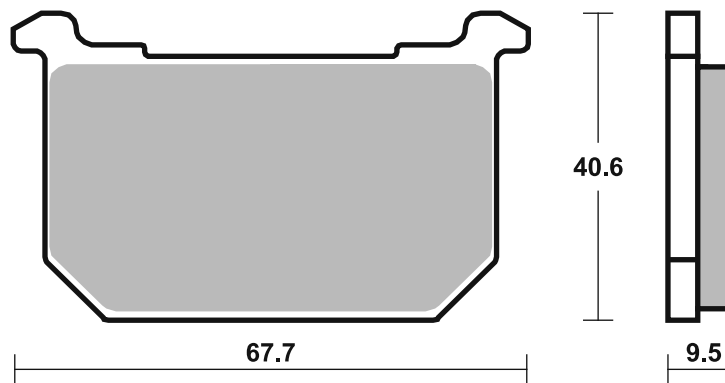

Brake Pad 1:1 Drawings,  
 Compounds, Fitments

## Applications

### SBS 541

### Recommended compound



#### HERCULES

GP	125 Supra	80 - 80	HF
----	-----------	---------	----

#### MALAGUTI

MEX	50	86 - 87	HF
MFX	50	86 - 87	HF
MGX	425 Ronco	87 - 11	HF

### SBS 542

### Recommended compound



#### HONDA

CB	125 TDC	83 - 89	HF
CBX	250 RSE	84 - 85	HF
GB	250 Clubman	88 - 97	HF
NS	250 R	85 - 85	HF
NSR	250 R	87 - 87	HF
	400 Xelvis	93 - 93	HF HF
CB	400	81 - 82	HF HF
CB	400 Four	81 - 85	HF
CB	400 Hawk	81 - 85	HF HF
CB	400 N	83 - 85	HF
CB	400 Twin	82 - 86	HF
CBR	400 F, Fil	85 - 85	HF HF
CBR	400 R	87 - 87	HF HF
CM	400 T	82 - 84	HF
GB	400 T.T.	88 - 92	HF
NS	400 R	85 - 87	LS
NV	400 Custom	88 - 88	HF
CB	450 T	82 - 86	HF
CM	450 A, C	82 - 86	HF
CMX	450 Rebel	86 - 88	HF
CBR	500 F (Austria)	87 - 90	LS
CX	500 C	81 - 82	HF
CX	500 Silver W., Turbo	83 - 85	HF HF
CX	500 Turbo	82 - 83	HF
FT	500	82 - 84	HF HF
GB	500 T.T.	88 - 92	HF
GL	500	82 - 82	HF
GL	500 D	81 - 82	HF
NS	500 R	85 - 85	HS LS
VF	500 F, Fil	84 - 86	HF HF
VT	500 C Shadow	83 - 86	HF
XBR	500 S	85 - 89	HF
CB	550 SC	83 - 84	HF
CBR	600 F Hurricane	87 - 90	LS
CBX	600 E	85 - 85	HF



#### HONDA

XL	600 LM, RM	85 - 87	HF
XL	600 V, Transalp	87 - 90	HS
CB	650	85 - 85	HF
CB	650 SC Nighthawk	83 - 85	HF
CBX	650 ED, SC, SCD	83 - 83	HF
CX	650 C	83 - 86	HF
CX	650 E	83 - 86	HF HF
CX	650 Turbo	83 - 86	HF HF
GL	650 D	83 - 84	HF
CB	700 SC	84 - 86	HF
VF	700 C Magna	84 - 84	HF
VF	700 C Magna	87 - 87	HF
VF	700 F Interceptor	84 - 85	HF
VF	700 S	84 - 85	HF
VFR	700 F, F2	86 - 87	LS
VT	700 C, Shadow	87 - 87	HF
CB	750 C	82 - 84	HF
CB	750 C, F, Fil, K	85 - 86	HF
CB	750 F	81 - 82	HF HF
CB	750 K	81 - 82	HF HF
CB	750 KZ	82 - 82	HF
CBR	750 Hurricane	87 - 00	LS
CBX	750	84 - 88	HF HF
CBX	750 F	84 - 88	HF HF
NV	750 CG Shadow	86 - 89	HF
VF	750 C	82 - 84	HF
VF	750 C, Magna	88 - 93	HF
VF	750 F	83 - 84	HF HF
VF	750 S	85 - 85	HF
VF	750 Sport	82 - 83	HF
VFR	750 F	86 - 87	LS
VP	750 CH, Custom	87 - 87	HF
VT	750 C, Shadow	86 - 96	HF
XLV	750 R	83 - 85	HF
VT	800 C	88 - 94	HF



#### HONDA

CB	900 C	82 - 82	HF HF
CB	900 F, F2	81 - 84	HF HF
CB	1000 C	83 - 84	HF HF
CBR	1000 F	87 - 88	LS
CBX	1000	81 - 82	HF
VF	1000 F, Fil	84 - 86	HF HF
VF	1000 Fil Bol d'Or	85 - 85	HF HF
VF	1000 R	84 - 87	HF
VT	1000 C	88 - 88	HF
CB	1100 F	83 - 85	HF HF
CB	1100 R, RD	81 - 83	HF HF
GL	1100 -1, DLX		
	Gold Wing	81 - 87	HF HF
GL	1100 Gold Wing	82 - 83	HF
VF	1100 C	83 - 86	HF
VF	1100 S	84 - 85	HF
VT	1100 C Shadow	87 - 93	HF
GL	1200 A, I Gold Wing	84 - 86	HF
GL	1200 DX Gold Wing	86 - 87	HF
GL	1200 Gold Wing	84 - 86	HF
GL	1500 A, SE,		
	I Gold Wing	94 - 99	LS
GL	1500 Gold Wing,		
	Gold Wing SE	88 - 99	LS
GLX	1500	88 - 99	HF

#### SYM

	110 Bullet	93 - 93	HF
	125 Aero Wolf	02 - 02	HF

STREET HF • HS • LS  
 AMERICAN H.HF • H.CT • H.HS • H.LS  
 SCOOTER HF • CT • MS

RACING  
 OFF ROAD  
 ATV

RST • DC • DCC • DS-1 • DS-2 • RQ  
 SI • RSI • CS  
 ATS • SI • RSI • PSI

Drawings 1:1

Available compounds

HF

SBS 541

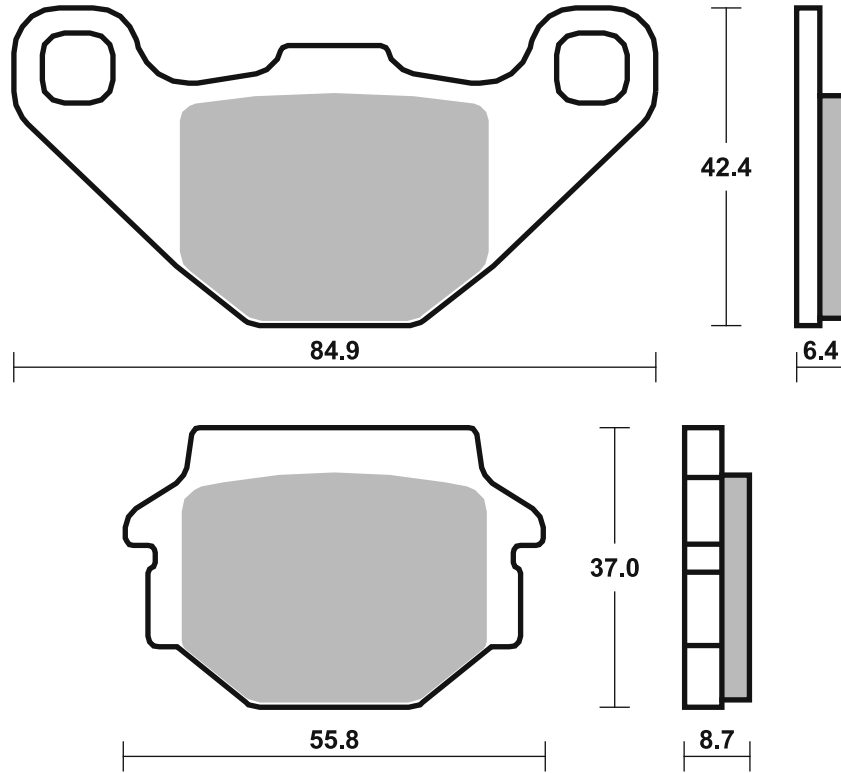

Available compounds

HF • HS • LS • DCC • RQ

SBS 542

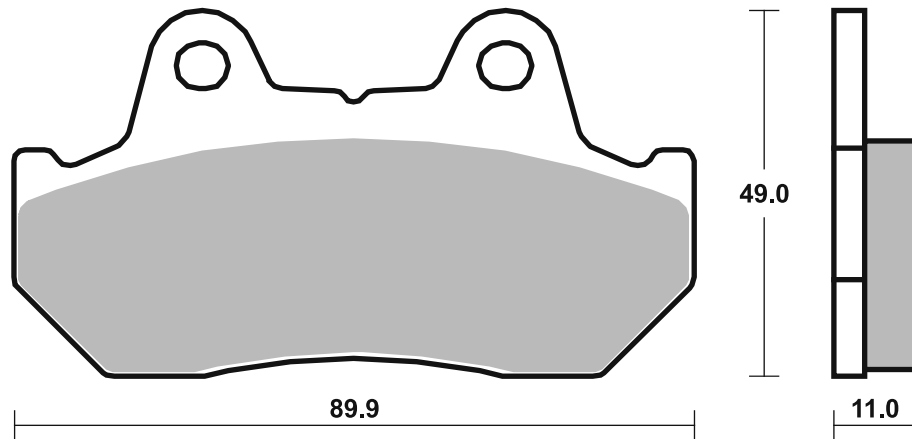



**HARLEY DAVIDSON**

XL	1000	78 - 78	<b>H.HF</b>
XLCH	1000	78 - 80	<b>H.HF</b>
XLH	1000 Sportster	79 - 82	<b>H.HF</b>
XLS	1000 Roadster	79 - 82	<b>H.HF</b>
FLH	1340 Classic	82 - 83	<b>H.HF</b>
FLH	1340 Electra Glide	82 - 83	<b>H.HF</b>
FLH	1340 Heritage	81 - 81	<b>H.HF</b>
FLT	1340 80	80 - 81	<b>H.HF</b>
FLT	1340 80 Classic	81 - 81	<b>H.HF</b>
FLT	1340 Classic	82 - 83	<b>H.HF</b>
FLT	1340 Tour Glide	82 - 82	<b>H.HF</b>

STREET HF • HS • LS  
AMERICAN H.HF • H.CT • H.HS • H.LS  
SCOOTER HF • CT • MS

RACING  
OFF ROAD  
ATV

RST • DC • DCC • DS-1 • DS-2 • RQ  
SI • RSI • CS  
ATS • SI • RSI • PSI

Drawings 1:1

Available compounds

H.HF • H.CT

SBS 543

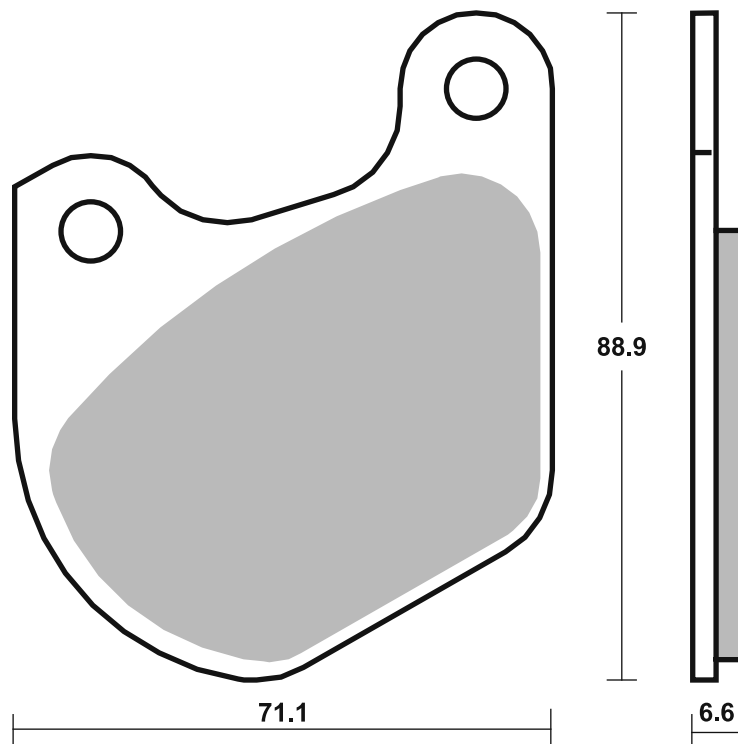
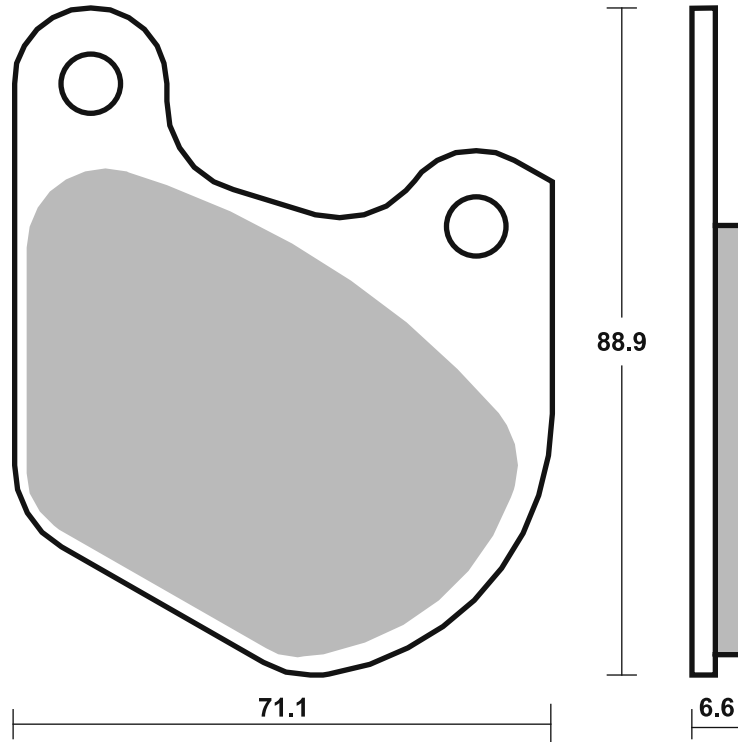



<b>ADLY</b>			
150 ATV	05 - 07	SI	SI
150 Interceptor	05 - 07	SI	SI
300 ATV	05 - 11	SI	SI

<b>AEON</b>			
100 Revo 2	04 - 06		SI
125 Pulsar	06 - 06	HF	

<b>APRILIA</b>			
125 Tuono ABS	17 - 19		HF
RS 125	17 - 19		HF
RS 125 GP	17 - 19		HF
RS-4 125 (J.Juan cal.)	11 - 19		HF
RS-4 125 Replica, ABS	16 - 19		HF
RX 125 Enduro	08 - 12		HF
RX 125 Supermotard	08 - 12		HF
SX 125	18 - 22		HF

<b>BOMBARDIER</b>			
200 Rally 2x4	03 - 06	SI	

<b>CAN-AM</b>			
DS 90 X	08 - 18	SI	SI

<b>CECTEK</b>			
500 EFI Gladiator	09 - 13		HF
500 EFI King Cobra	09 - 13		HF
500 EFI Quadrift	09 - 11		HF
500 i Estoc	10 - 10		HF

<b>CPI</b>			
XS 250 Quad	06 - 08	SI	

<b>DAELIM</b>			
ST 250 Sector Quad	05 - 06	SI	

<b>DERBI</b>			
DXR 200 Quad (Front disc)	04 - 07	SI	
DXR 250 Quad (Front disc)	04 - 07	SI	

<b>E-TON</b>			
VXL 250 Vector, ST Vector	06 - 07	SI	
VTX 300 Vortex, ST Vortex	07 - 07	SI	
VXL 300 Vector, ST Vector	07 - 13	SI	

<b>FACTORY</b>			
50 Helix	04 - 06		SI
50 Rex	04 - 06		SI
100 Helix	04 - 06		SI
100 Rex	04 - 06		SI

<b>FANTIC</b>			
125 Regolarna Casa	08 - 08		HF
125 Supersei Motard	08 - 08		HF

<b>HYOSUNG</b>			
GD 125 EXIV	12 - 16		HF

<b>KAWASAKI</b>			
AR 50	81 - 82		HF
KMX 50	88 - 93		HF
KSR 50 I (50)	90 - 91		HF HF
AR 80	81 - 82		HF
KD 80	88 - 90		HF
KSR 80 II (80)	90 - 91		HF HF
KX 80	84 - 87		SI
KX 80	88 - 96		RSI
KX 100	88 - 96		RSI
KDX 125	90 - 94		SI
KMX 125	86 - 86		HF



<b>KAWASAKI</b>			
KX 125	82 - 82	SI	
ZL 125 Eliminator	97 - 99	HF	
KMX 200	88 - 90	HF	
KX 250	82 - 82	SI	
KXT 250 Tecate	84 - 84		HF

<b>MALAGUTI</b>			
125 Dune	19 - 23		HF
125 Dune X	19 - 23		HF
125 Monte Pro	19 - 23		HF
XSM 125	19 - 23		HF
XTM 125	19 - 23		HF

<b>PGO</b>			
50 X-Rider	03 - 10		SI
125 X-Rider	03 - 10		SI
150 X-Rider	03 - 10		SI

<b>POLARIS</b>			
200 Phoenix	05 - 09	ATS	
200 Sawtooth	06 - 07	ATS	ATS

<b>RIEJU</b>			
RS2 125 NKD	06 - 07		HF
RS2 125 Pro	08 - 12		HF

<b>ROXON</b>			
150 Quad Sport Spirit	06 - 06		SI

<b>SUZUKI</b>			
CC 50 Tune	92 - 97		HF
LIDO 75 Style	84 - 94		HF
RM 80	90 - 95		SI
RM 80	96 - 01		RSI
ZZ 80 Sepia	90 - 92		HF
RM 85	02 - 04		RSI

<b>TM</b>			
80 Junior	96 - 00		RSI

<b>YAMAHA</b>			
YFM 300 Grizzly	12 - 13		SI

<b>ZERO</b>			
DS ZF6.0	10 - 12		HF
DS ZF9.0	10 - 12		HF
MX	10 - 12		HF
S ZF6.0	10 - 12		HF
X	10 - 12		HF
XU	11 - 12		HF

STREET HF • HS • LS  
AMERICAN H.HF • H.CT • H.HS • H.LS  
SCOOTER HF • CT • MS

RACING  
OFF ROAD  
ATV

RST • DC • DCC • DS-1 • DS-2 • RQ  
SI • RSI • CS  
ATS • SI • RSI • PSI

Available compounds

HF • CS • SI • RSI • ATS

SBS 544

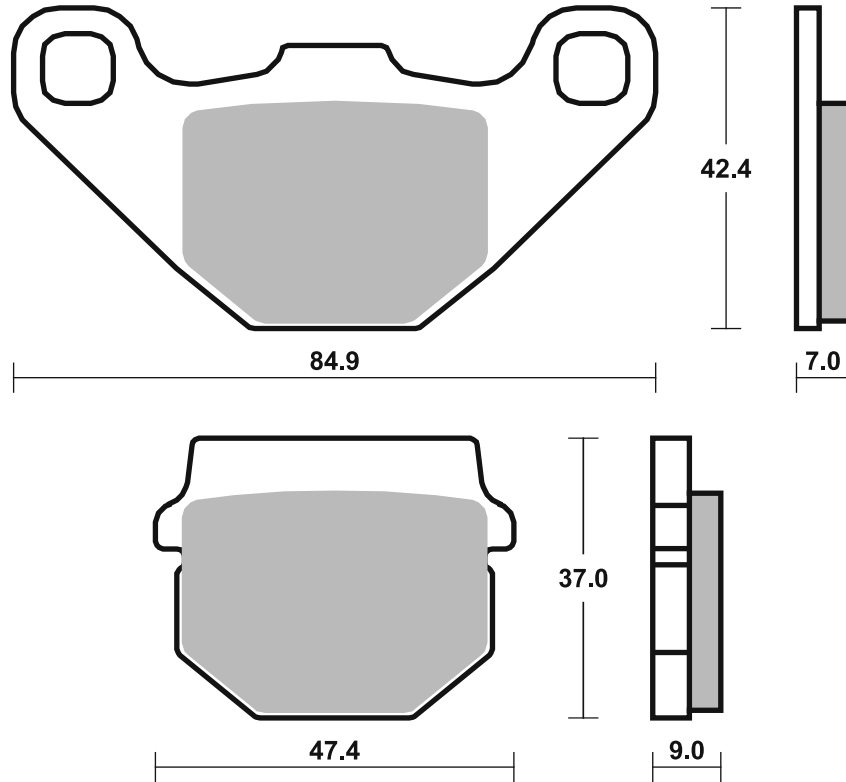



<b>YAMAHA</b>			
GX	250	80 - 85	<b>HF</b>
RD	250 DX	80 - 80	<b>HF</b>
XS	400 SE	80 - 81	<b>HF</b>
XJ	650 G, H, SH	80 - 83	<b>HF</b>
XS	650	80 - 82	<b>HF</b>
XS	750 H, J, K	81 - 82	<b>HF</b>
XS	750 SE	79 - 80	<b>HF</b>
XV	750 SE	81 - 83	<b>HF</b>
XS	850	81 - 81	<b>HF</b>
XV	920 K, MK, Virago	83 - 83	<b>HF</b>
XS	1100 SF, SG, SH, LG	79 - 81	<b>HF</b>



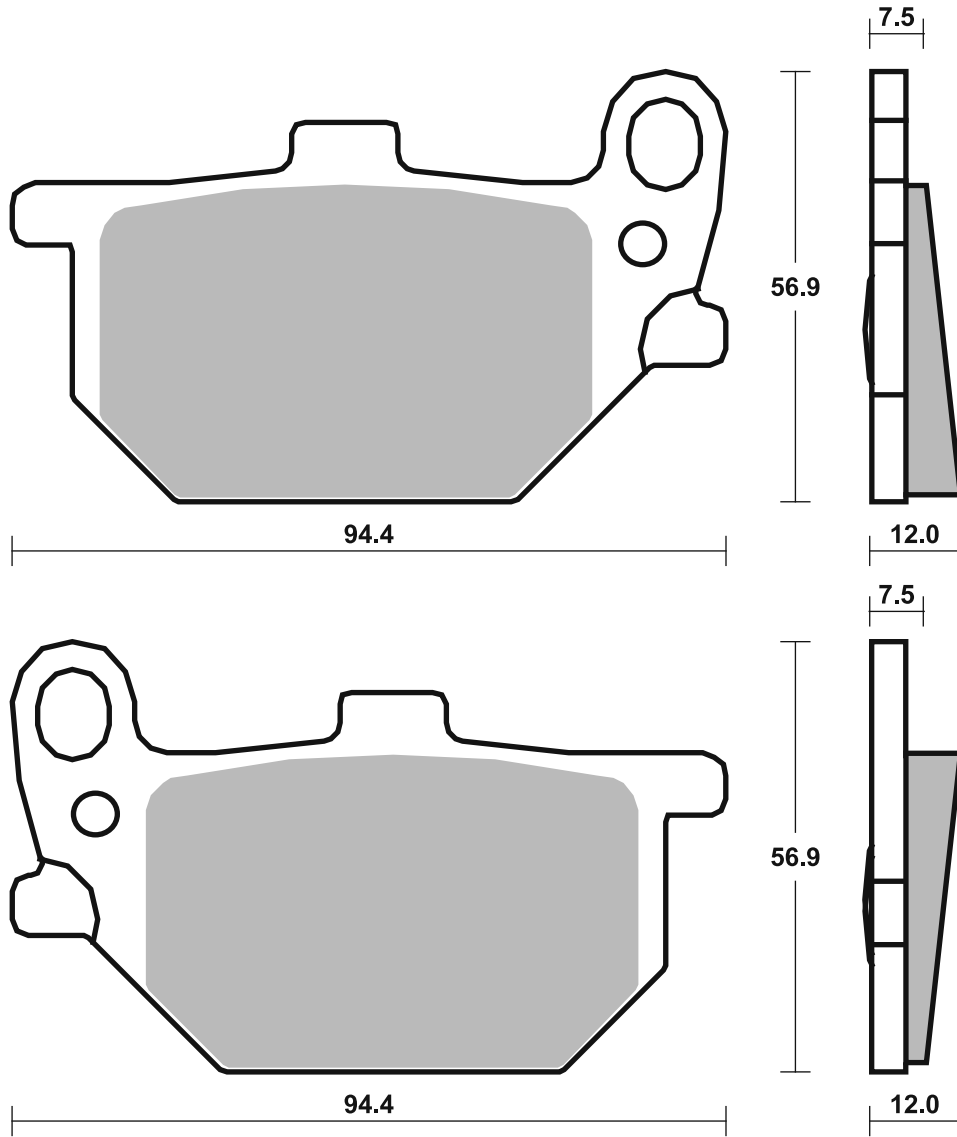

## Applications

### SBS 546

### Recommended compound



<b>BATAVUS</b>			
50 Grand Prix	80 - 80	<b>HF</b>	
<b>BOMBARDIER</b>			
200 Rally 2x4	05 - 06		<b>SI</b>
<b>KAWASAKI</b>			
KH 100 EX	88 - 93	<b>HF</b>	
KH 100 GH	83 - 87	<b>HF</b>	
AR 125	82 - 94	<b>HF</b>	
KE 125	86 - 91	<b>HF</b>	
KH 125	82 - 98	<b>HF</b>	
KX 125	83 - 85	<b>SI</b>	
KX 125	86 - 86	<b>RSI</b>	
KDX 200 C	86 - 88	<b>SI</b>	
KDX 200 SR	89 - 92	<b>SI</b>	
Z 200	83 - 85	<b>HF</b>	
250 Estrella	92 - 99	<b>HF</b>	
GPZ 250 Belt Drive	83 - 84	<b>HF</b>	
KL 250 (KLR 250)	85 - 97	<b>HF</b>	
KLR 250	84 - 05	<b>HF</b>	
KR 250	85 - 85	<b>HF</b>	
KX 250	83 - 85	<b>SI</b>	
KX 250	86 - 86	<b>RSI</b>	
KXT 250 Tecate	85 - 86	<b>SI</b>	
Z 250 T, Scorpion	89 - 89	<b>HF</b>	
KLF 300 Bayou	88 - 04	<b>SI</b>	
GPZ 305	81 - 96	<b>HF</b>	
KLR 350	85 - 85	<b>HF</b>	
FX 400 R	86 - 88	<b>HF</b>	
GPZ 400	85 - 87	<b>HF</b>	
LX 400 Eliminator, SE	90 - 90	<b>HF</b>	



<b>KAWASAKI</b>			
Z 400 F	84 - 86	<b>HF</b>	
ZR 400 F	83 - 84	<b>HF</b>	
ZX 400	85 - 85	<b>HF</b>	
GPZ 500	95 - 96	<b>HF</b>	
GPZ 500 S	88 - 88	<b>HF</b>	
GPZ 500 S	89 - 92	<b>HS</b>	
KX 500	83 - 85	<b>SI</b>	
KX 500	86 - 86	<b>RSI</b>	
ZR 500 (Z 500 F)	83 - 87	<b>HF</b>	
KX 550 A	83 - 83	<b>SI</b>	
Z 550 F	83 - 84	<b>HF</b>	
Z 550 GT	83 - 01	<b>HF</b>	
ZR 550 A1, GP	83 - 84	<b>HF</b>	
KL 600	84 - 86	<b>HF</b>	
KLR 600	84 - 86	<b>HF</b>	
KLR 600 E	85 - 94	<b>HF</b>	
<b>KTM</b>			
GS 125	89 - 90	<b>SI</b>	
MX 125	89 - 90	<b>SI</b>	
GS 250	89 - 90	<b>SI</b>	
MX 250	89 - 90	<b>SI</b>	
MX 300	90 - 90	<b>SI</b>	
LC4 350	92 - 95	<b>SI</b>	
MX 500	89 - 91	<b>SI</b>	
<b>LAVERDA</b>			
700 El Cid	90 - 90	<b>HF</b>	
<b>POLARIS</b>			
170 Ranger RZR	17 - 21		<b>SI</b>



<b>POLARIS</b>			
200 Phoenix	05 - 14		<b>SI</b>
<b>SUZUKI</b>			
50 Wolf	89 - 94	<b>HF</b>	
RB 50	87 - 87	<b>HF</b>	
GT 80 L/C	81 - 81	<b>HF</b>	
RG 80 Gamma	85 - 87	<b>HF</b>	
TRS 118	82 - 83	<b>HF</b>	
GN 125	91 - 04	<b>HF</b>	
GS 125 ESZ	82 - 82	<b>HF</b>	
GT 125	80 - 82	<b>HF</b>	
TR 125	83 - 86	<b>HF</b>	
TU 125 XT	99 - 99	<b>HF</b>	
X4 125 , X3E	78 - 80	<b>HF</b>	
ET 240	86 - 86	<b>HF</b>	
NZ 250	86 - 91	<b>HF</b>	
GSX 400 EFX	82 - 82	<b>HF</b>	
GSX 400 FD	83 - 83	<b>HF</b>	
GSX 400 FX, FZ	81 - 82	<b>HF</b>	
GSX 400 S, Katana	83 - 86	<b>HF</b>	
GS 450	86 - 86	<b>HF</b>	

### SBS 547

### Recommended compound



<b>YAMAHA</b>			
RD 50 MX	81 - 87	<b>HF</b>	
RX 50 K	83 - 85	<b>HF</b>	
RD 80 MX	81 - 86	<b>HF</b>	
RX 80 SE	82 - 84	<b>HF</b>	
RD 250 LC	81 - 82	<b>HF</b>	
RD 350 LC	81 - 82	<b>HF</b>	
XJ 400 Maxim, Seca	81 - 81	<b>HF</b>	
XJ 500 (Austria)	81 - 83	<b>HF</b>	
XJ 550 Maxim	81 - 83	<b>HF</b>	
XJ 550 Seca	81 - 83	<b>HF</b>	
XZ 550	82 - 82	<b>HF</b>	
750 Maxim	81 - 81	<b>HF</b>	
XJ 750 Seca	81 - 83	<b>HF</b>	
XV 920 J	82 - 82	<b>HF</b>	
XV 920 Virago	81 - 81	<b>HF</b>	
XV 1000 SE	83 - 85	<b>HF</b>	
1100 SE, Maxim	81 - 81	<b>HF</b>	
XJ 1100	81 - 81	<b>HF</b>	
XS 1100 LH Midnight	81 - 81	<b>HF</b>	

STREET HF • HS • LS  
 AMERICAN H.HF • H.CT • H.HS • H.LS  
 SCOOTER HF • CT • MS

RACING  
 OFF ROAD  
 ATV

RST • DC • DCC • DS-1 • DS-2 • RQ  
 SI • RSI • CS  
 ATS • SI • RSI • PSI

Drawings 1:1

Available compounds

HF • HS • SI • RSI

SBS 546

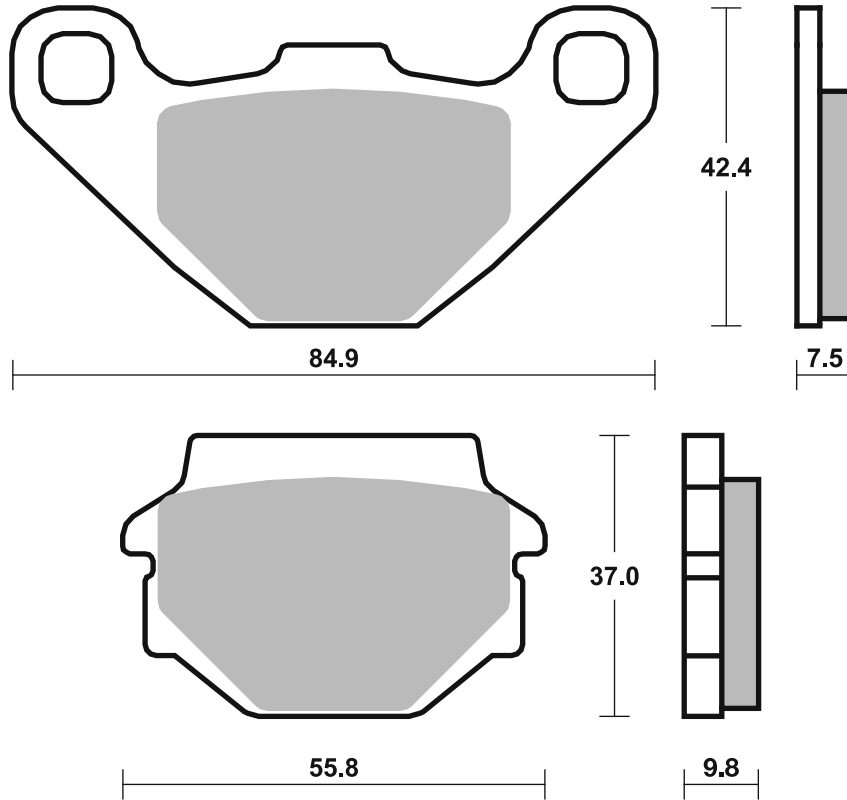

Available compounds

HF • DCC

SBS 547

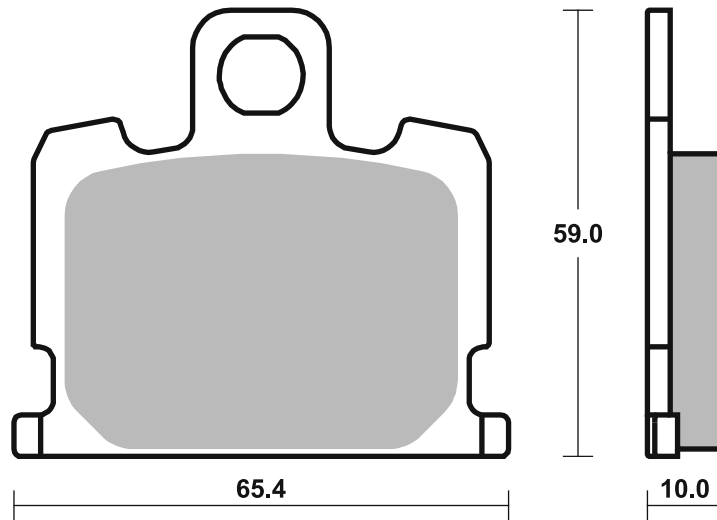



STREET HF • HS • LS  
 AMERICAN H.HF • H.CT • H.HS • H.LS  
 SCOOTER HF • CT • MS

RACING  
 OFF ROAD  
 ATV

RST • DC • DCC • DS-1 • DS-2 • RQ  
 SI • RSI • CS  
 ATS • SI • RSI • PSI

Available compounds

HF

SBS 548

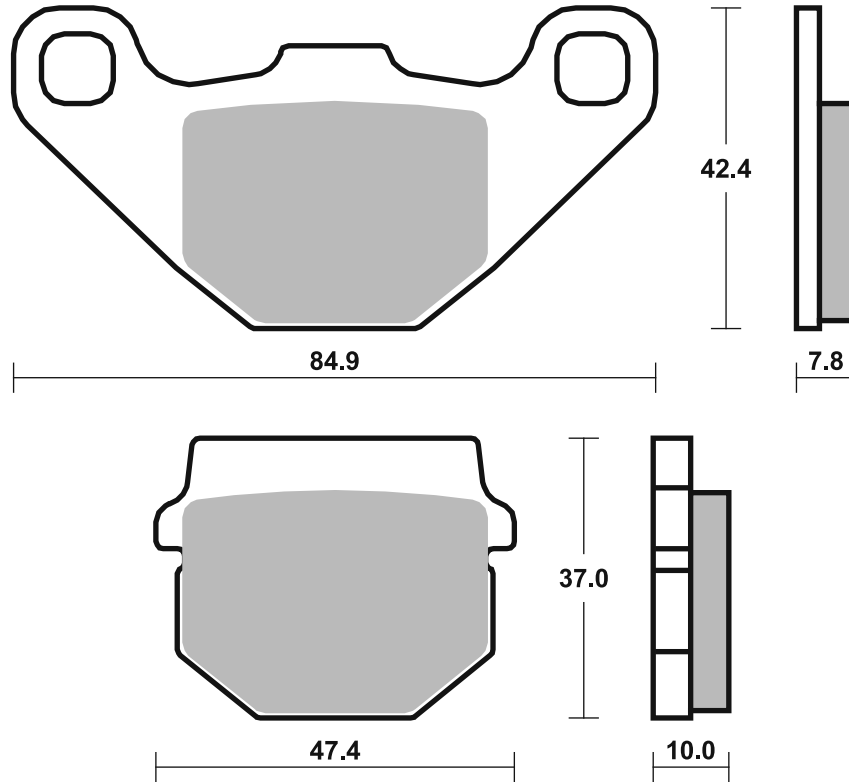

Available compounds

H.HF • H.CT

SBS 549

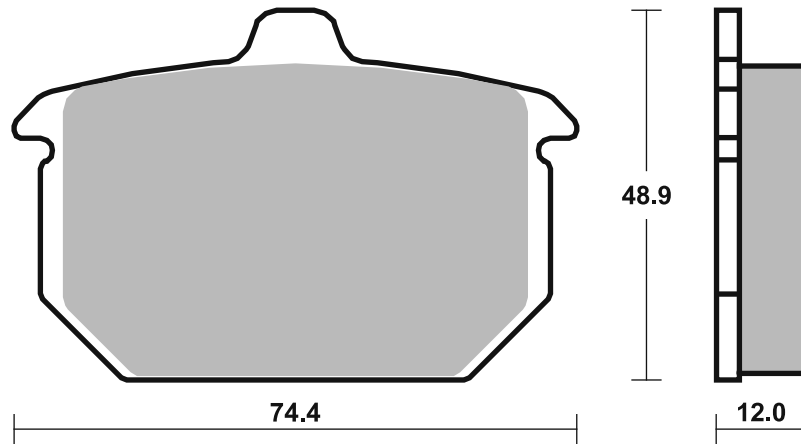

## Applications

### SBS 550

### Recommended compound



YAMAHA			
DT	80 LC	81 - 84	HF
RD	80 LC	81 - 82	HF
RX	100	84 - 87	HF
RX	115 S	82 - 85	HF
RD	125 LC	82 - 84	HF
SR	125	92 - 96	HF
XV	240 Virago	92 - 98	HF
RD	250 LC	83 - 84	HF
XV	250 Route 66	88 - 90	HF
XV	250 Virago	88 - 88	HF
RD	350 LC YPVS	83 - 84	HF
RZ	350	84 - 85	HF
XJ	400	82 - 82	HF HF
XS	400	82 - 85	HF
XS	400 DOHC	82 - 82	HF
XS	500 DOHC	82 - 82	HF
XT	500 (Austria)	83 - 83	HF
XV	500 K, Virago	83 - 83	HF



YAMAHA			
XV	500 SE	83 - 83	HF
XZ	550	83 - 84	HF
XZ	550 RJ, RK	82 - 83	HF
XZ	550 S	83 - 84	HF
XT	600	83 - 86	HF
XT	600 Tenere	83 - 84	HF
XJ	650	83 - 83	HF
XJ	650 Turbo	81 - 82	HF
XJ	750 Maxim	82 - 82	HF
XV	920 K, MK, Virago	83 - 83	HF

### SBS 551

### Recommended compound



FACTORY			
YR	125	06 - 06	HF
HONDA			
MBX	80	83 - 85	HF
MBX	80 DX	82 - 86	HF
MBX	80 SW, SWD	83 - 83	HF
CBX	125 Custom	88 - 88	HF
FS	125 Sonic	03 - 04	HF
MBX	125 RWB	84 - 86	HF
CB	250 Rebel	86 - 96	HF
CMX	250 Rebel	85 - 12	HF
HYOSUNG			
	125 Grand Prix Plus	02 - 05	HF
GT	125 Comet	02 - 03	HF
GV	125 Aguila	02 - 04	HF
RT	125 Karion	02 - 06	HF
RX	125	00 - 07	HF



HYOSUNG			
XRX	125 Offroad	99 - 06	HF
GV	250	02 - 09	HF
XRX	400	05 - 08	HF
	600 Comet	03 - 03	HF
GV	650 Aguila	04 - 05	HF
KYMCO			
CK	125	04 - 13	HF
DX	150 Custom	93 - 96	HF
NSR	150	93 - 93	HF
SYM			
	125 Wolf Classic	05 - 05	HF
MF	180	03 - 03	HF

### SBS 552

### Recommended compound



HONDA			
VT	250 F	83 - 87	HF
VTR	250	88 - 89	HF
CBX	400 F, F2, F2C	82 - 84	HF
VF	400 F	85 - 86	HF
VF	400 FD	83 - 85	HF
VT	400 E	83 - 86	HF
VT	500 E	83 - 85	HF
VT	500 ED	82 - 82	HF
CBX	550 F, F2	82 - 86	HF
CBX	650 E	83 - 90	HF

STREET HF • HS • LS  
 AMERICAN H.HF • H.CT • H.HS • H.LS  
 SCOOTER HF • CT • MS

RACING  
 OFF ROAD  
 ATV

RST • DC • DCC • DS-1 • DS-2 • RQ  
 SI • RSI • CS  
 ATS • SI • RSI • PSI

Drawings 1:1

Available compounds HF • DCC

SBS 550

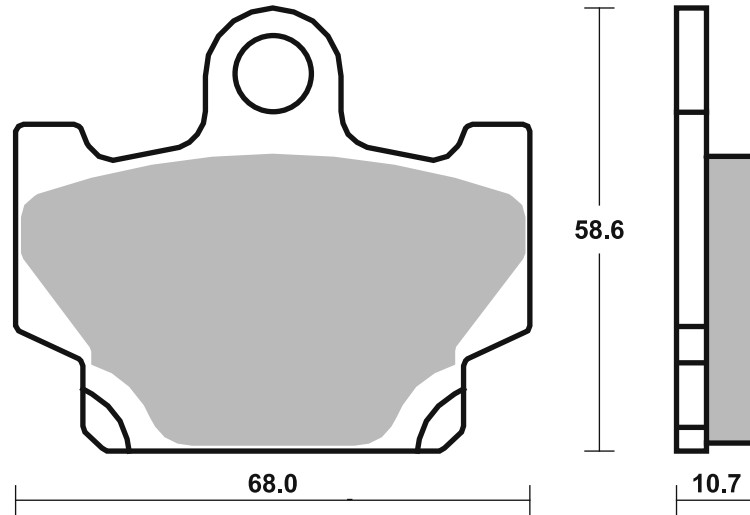

Available compounds HF

SBS 551

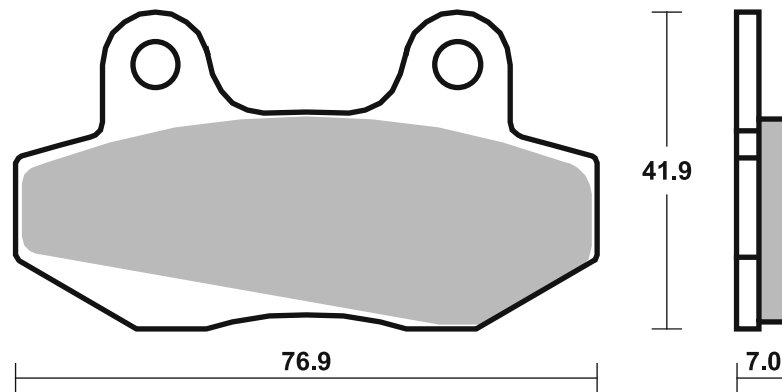

Available compounds HF

SBS 552

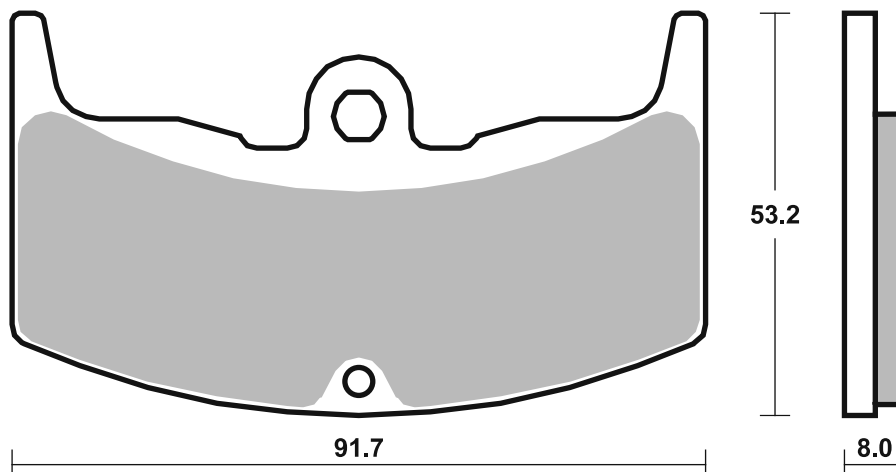



**HARLEY DAVIDSON**

FLH	1200	80 - 80	<b>H.HF</b>
FLH	1340 80	81 - 81	<b>H.HF</b>
FLH	1340 Classic	82 - 83	<b>H.HF</b>
FLH	1340 Electra Glide		
	Spec.	84 - 84	<b>H.HF</b>
FLH	1340 Heritage	81 - 81	<b>H.HF</b>
FLHT	1340 Tour Glide	84 - 84	<b>H.HF</b>
FLT	1340	84 - 85	<b>H.HF</b>
FLT	1340 80	80 - 81	<b>H.HF</b>
FLT	1340 80 Classic	81 - 81	<b>H.HF</b>
FLT	1340 Classic	82 - 83	<b>H.HF</b>
FLT	1340 Tour Glide	82 - 82	<b>H.HF</b>



STREET HF • HS • LS  
AMERICAN H.HF • H.CT • H.HS • H.LS  
SCOOTER HF • CT • MS

RACING  
OFF ROAD  
ATV

RST • DC • DCC • DS-1 • DS-2 • RQ  
SI • RSI • CS  
ATS • SI • RSI • PSI

Available compounds

H.HF • H.CT

SBS 553

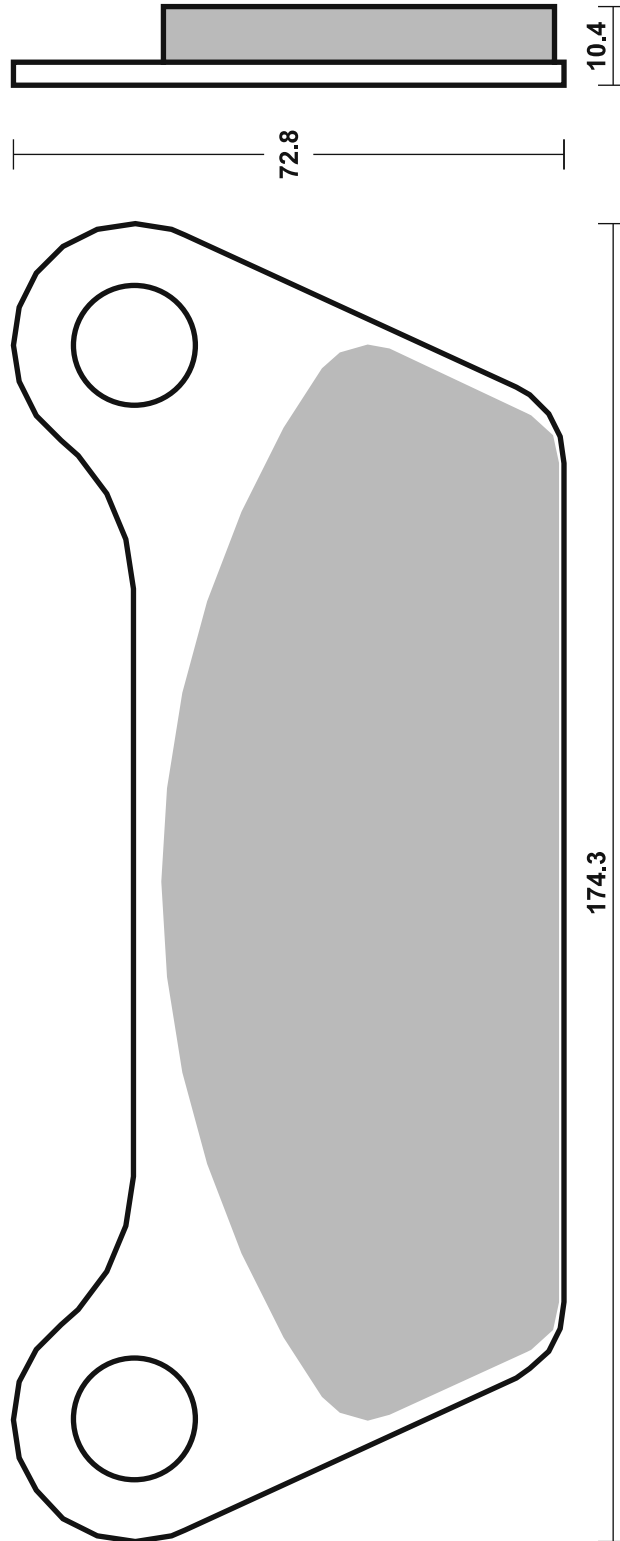

## Applications

### SBS 554

### Recommended compound



<b>BENELLI</b>			
	900 Sei	81 - 83	<b>HF</b>
<b>BMW</b>			
R65/1	650	86 - 86	<b>HF</b>
R80	800	86 - 88	<b>HF</b>
R80	800 GS Mystic	91 - 95	<b>HS</b>
R80	800 GS Paris Dakar	88 - 94	<b>HS</b>
R80	800 RT	84 - 85	<b>HF</b>
R100	1000 GS	87 - 94	<b>HF</b>
R100	1000 GS Mystic	91 - 94	<b>HS</b>
R100	1000 RT	91 - 95	<b>HS</b>
<b>MOTO-GUZZI</b>			
	1000	81 - 83	<b>HF HF</b>
SP	1000 Le Mans	79 - 83	<b>HF</b>
<b>TRIUMPH</b>			
	750 Bonneville	84 - 84	<b>HF</b>

### SBS 555

### Recommended compound



<b>YAMAHA</b>			
TZR	125	89 - 92	<b>HF</b>
TZR	125	93 - 94	<b>HF</b>
FZ	250 Phazer N, S	85 - 86	<b>HF</b>
RD	250 LC	83 - 84	<b>HF</b>
YD	250 S	90 - 90	<b>HF</b>
RD	350 LC YPVS	83 - 84	<b>HF</b>
RZ	350	84 - 85	<b>HF</b>
FZ	400 N	87 - 87	<b>HF</b>
FZR	400	87 - 87	<b>HF</b>
XJR	400 R	95 - 96	<b>LS</b>
XS	400 Z	83 - 83	<b>HF HF</b>
FZR	500 (Austria)	89 - 89	<b>HF HF</b>
FZR	500 R (Austria)	90 - 91	<b>LS</b>
RD	500	83 - 83	<b>HF HF</b>
RD	500 LC	84 - 85	<b>HF</b>
RZ	500	84 - 86	<b>HF</b>
FJ	600	84 - 85	<b>HF HF</b>
FZ	600	86 - 87	<b>HF HF</b>
FZ	600 S, SC	86 - 89	<b>HF</b>
FZR	600	89 - 89	<b>HF HF</b>
FZR	600 R	90 - 95	<b>LS</b>
XJ	600	83 - 91	<b>HF HF</b>
YX	600 Radian	87 - 90	<b>HF</b>
YZF	600 R Thunder Cat	96 - 03	<b>LS</b>
FZ	700	87 - 88	<b>HF HF</b>
FZX	700 Fazer	87 - 88	<b>HF HF</b>
XJ	700	86 - 89	<b>HF</b>
XJ	700 Maxim	85 - 89	<b>HF HF</b>
XV	700 L, LC	84 - 87	<b>HF</b>
XV	700 Virago	87 - 87	<b>HF</b>
	750 Maxim	81 - 81	<b>HF</b>



<b>YAMAHA</b>			
FZ	750	85 - 86	<b>HF HF</b>
FZ	750 Genesis	86 - 86	<b>HF HF</b>
FZ	750 Genesis	87 - 88	<b>HF HF</b>
FZ	750 Genesis	89 - 92	<b>LS</b>
FZR	750 R	89 - 92	<b>LS</b>
FZR	750 R Genesis	87 - 88	<b>HF</b>
FZX	750 Fazer	86 - 90	<b>HF HF</b>
TX	750 A	73 - 76	<b>HF</b>
VF	750 Virago	88 - 88	<b>HF</b>
XJ	750	83 - 87	<b>HF HF</b>
XV	750	89 - 92	<b>HS</b>
YZF	750 R, SP	93 - 97	<b>LS</b>
TDM	850	91 - 01	<b>LS</b>
TRX	850	95 - 00	<b>LS</b>
TRX	850 (Italy)	95 - 99	<b>LS</b>
XJ	900	83 - 93	<b>HF HF</b>
XJ	900 F	85 - 93	<b>HF HF</b>
XJ	900 S, Diversion	94 - 03	<b>LS</b>
XV	920 Virago	81 - 81	<b>HF</b>
FJ	1000 L, LC	84 - 84	<b>HF HF</b>
FZR	1000	94 - 95	<b>LS</b>
FZR	1000 EX UP	90 - 93	<b>LS</b>
FZR	1000 Genesis	87 - 89	<b>HF</b>
GTS	1000	93 - 99	<b>HF</b>
XV	1000 L, C	84 - 85	<b>HF HF</b>
XV	1000 Virago	86 - 88	<b>HF HF</b>
YZF	1000 R Thunder Ace	96 - 99	<b>LS</b>
BT	1100 Bulldog	02 - 06	<b>LS</b>
FJ	1100	83 - 85	<b>HF HF</b>
XV	1100 Virago	86 - 93	<b>HF</b>
XV	1100 Virago	99 - 99	<b>LS</b>



<b>YAMAHA</b>			
XVS	1100 A Drag Star		
	Classic	00 - 06	<b>LS</b>
XVS	1100 Drag Star	99 - 06	<b>LS</b>
FJ	1200	86 - 87	<b>HF HF</b>
FJ	1200 ABS	91 - 93	<b>LS</b>
V-MAX	1200	85 - 89	<b>HF HF</b>
V-MAX	1200	90 - 92	<b>HS LS</b>
XJR	1200	94 - 98	<b>LS</b>
XJR	1200 (Italy)	95 - 98	<b>LS</b>
XJR	1200 SP	97 - 98	<b>LS</b>
XV	1200	84 - 87	<b>HF HF</b>
XV	1200 Venture Royale	85 - 85	<b>HF HF</b>
XV	1200 Z12T	84 - 87	<b>HF HF</b>
XVT	1200 T, Vent. Royale	84 - 85	<b>HF HF</b>
XJR	1300	99 - 01	<b>LS</b>
XJR	1300 SP	01 - 01	<b>LS</b>

STREET HF • HS • LS  
AMERICAN H.HF • H.CT • H.HS • H.LS  
SCOOTER HF • CT • MS

RACING  
OFF ROAD  
ATV

RST • DC • DCC • DS-1 • DS-2 • RQ  
SI • RSI • CS  
ATS • SI • RSI • PSI

Available compounds

HF • HS

SBS 554

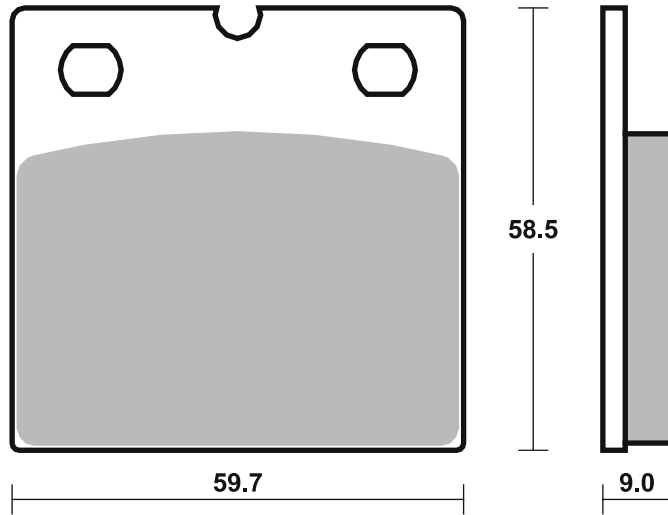

Available compounds

HF • HS • LS • DCC • RQ

SBS 555

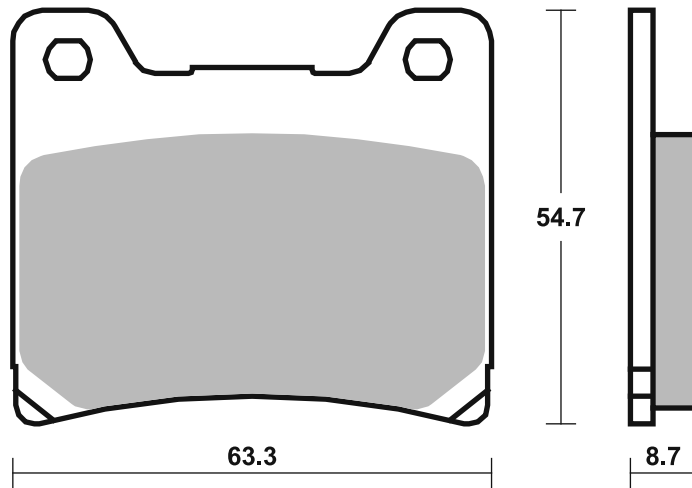

## Applications

### SBS 556

### Recommended compound



<b>HYOSUNG</b>			
GT	250 Comet	02 -02	<b>LS</b>
	600 Comet	02 -02	<b>LS</b>

<b>KAWASAKI</b>			
Z	250	78 -80	<b>HF</b>
Z	250 J	81 -85	<b>HF</b>
ZX-4	400	90 -90	<b>LS</b>
ZXR	400	89 -90	<b>HF</b>
ZXR	400	91 -02	<b>LS</b>
	600 R, Ninja	89 -96	<b>HF</b>
ZX-7R	750 Ninja	89 -03	<b>LS</b>
ZXR	750 R	89 -95	<b>LS</b>
ZRX	1100	96 -00	<b>LS</b>
ZX	1100	93 -97	<b>LS</b>
ZZR	1100	94 -01	<b>LS</b>
ZRX	1200	01 -04	<b>LS</b>
ZRX	1200 R	01 -08	<b>LS</b>
ZRX	1200 S	01 -07	<b>LS</b>
ZX-12R	1200 Ninja	00 -06	<b>LS</b>
ZZR	1200	02 -04	<b>LS</b>

<b>SUZUKI</b>			
RG	125 Wolf	92 -94	<b>HF</b>
	250 Across	90 -99	<b>HF</b>
	250 Bandit	90 -96	<b>LS</b>
	250 Cobra	90 -92	<b>LS</b>
	250 Wolf	90 -92	<b>LS</b>
GF	250	88 -88	<b>HF</b>
GSX	250 S, Katana	91 -91	<b>LS</b>
GSX-R	250	88 -89	<b>HF</b>
GSX-R	250 R	89 -91	<b>LS</b>
RG	250	83 -84	<b>HF HF</b>



<b>SUZUKI</b>			
RG	250 Gamma	84 -88	<b>HF</b>
RGV	250	88 -88	<b>LS</b>
RGV	250	89 -90	<b>HF</b>
TV	250	88 -88	<b>HF</b>
	350 Goose	92 -99	<b>HF</b>
GSF	400 Bandit	91 -97	<b>LS</b>
GSX	400 F	89 -92	<b>HF</b>
GSX	400 FWS	83 -83	<b>HF HF</b>
GSX	400 Impulse	94 -96	<b>LS</b>
GSX	400 S, Katana	92 -92	<b>LS</b>
GSX	400 X	86 -89	<b>HF</b>
GSX-R	400	87 -89	<b>HF</b>
GSX-R	400 F	85 -86	<b>HF</b>
GSX-R	400 R	90 -95	<b>LS</b>
RF	400 RVC	93 -97	<b>LS</b>
GS	500	89 -03	<b>LS</b>
GS	500	04 -08	<b>HF</b>
GS	500 F	04 -08	<b>HF</b>
GSX	500	83 -85	<b>HF HF</b>
RG	500	85 -87	<b>HF</b>
RG	500 Gamma	85 -86	<b>HF</b>
GS	550	83 -86	<b>HF HF</b>
GSX	550	83 -87	<b>HF HF</b>
GSF	600 Bandit	95 -99	<b>LS</b>
GSF	600 Bandit / S Bandit	00 -04	<b>LS</b>
GSX	600 F	89 -97	<b>LS</b>
GSX	600 FW	98 -04	<b>LS</b>
GSX	600 Katana	88 -89	<b>HF</b>
GSX	600 Katana	90 -97	<b>LS</b>
GSX-R	600	92 -93	<b>LS</b>
GSX-R	600	97 -03	<b>LS</b>
RF	600 R	93 -96	<b>LS</b>



<b>SUZUKI</b>			
SV	650 S	99 -02	<b>LS</b>
GS	750 Katana	85 -86	<b>HF HF</b>
GS	750 RF	85 -85	<b>HF HF</b>
GSX	750	89 -08	<b>LS</b>
GSX	750 ES	84 -85	<b>HF HF</b>
GSX	750 F	03 -06	<b>LS</b>
GSX	750 FW	98 -02	<b>LS</b>
GSX	750 Katana	89 -96	<b>LS</b>
GSX-R	750	85 -87	<b>HF</b>
GSX-R	750	88 -99	<b>LS</b>
TL	1000 RW	98 -02	<b>LS</b>
TL	1000 S V-Twin	97 -01	<b>LS</b>
GSX	1100	86 -87	<b>HF HF</b>
GSX	1100 F	93 -96	<b>LS</b>
GSX	1100 G	96 -98	<b>LS</b>
GSX	1100 Katana	93 -93	<b>LS</b>
GSX-R	1100	86 -88	<b>HF</b>
GSX-R	1100	89 -97	<b>LS</b>
GSF	1200 Bandit	95 -00	<b>LS</b>
GSF	1200 S Bandit	01 -05	<b>LS</b>
GSX	1200	99 -01	<b>LS</b>
GSX-R	1300 Hayabusa	99 -07	<b>LS</b>

### SBS 557

### Recommended compound



<b>HYOSUNG</b>			
	125 GA-4	99 -99	<b>HF</b>
GA	300	98 -01	<b>HF</b>

<b>KAWASAKI</b>			
BR	250	86 -90	<b>HF</b>
CS	250	86 -90	<b>HF</b>
EL	250	91 -94	<b>HF</b>
EL	250 Eliminator	88 -89	<b>HF</b>
EX	250 R Ninja	86 -87	<b>HF HF</b>
GPZ	250	83 -85	<b>HF</b>
GPZ	250 R	86 -87	<b>HF HF</b>
KR	250	85 -85	<b>HF</b>
LX	250 Eliminator, SE	90 -95	<b>HS</b>
Z	250 Eliminator	88 -88	<b>HF</b>
EL	252	97 -00	<b>HS</b>
EX	305	83 -83	<b>HF</b>
	400 Eliminator	94 -95	<b>LS</b>
EN	400 Twin	85 -89	<b>HF</b>
FX	400 R	86 -88	<b>HF</b>
GPZ	400	85 -87	<b>HF</b>
KLE	400 Vulcan	90 -90	<b>HS</b>
Z	400 Eliminator	88 -88	<b>HF HF</b>
ZX	400	85 -87	<b>HF</b>
ZX	400	86 -87	<b>HF HF</b>
EN	450	85 -90	<b>HF</b>
Z	450 LTD	84 -89	<b>HF</b>
EN	500	90 -04	<b>HS</b>
EN	500 Vulcan	96 -97	<b>HS</b>
GPZ	500 R (Austria)	85 -87	<b>HF HF</b>
GPZ	500 S	87 -87	<b>HF</b>



<b>KAWASAKI</b>			
GPZ	500 S	89 -92	<b>LS</b>
ZL	500 (Austria)	85 -90	<b>HF HF</b>
GPZ	550	84 -87	<b>HF HF</b>
GT	550	85 -01	<b>HF</b>
Z	550 F	85 -88	<b>HF</b>
ZX	550	84 -89	<b>HF HF</b>
GPZ	600 R	85 -89	<b>HF HF</b>
Z	600 GP	83 -89	<b>HF HF</b>
ZL	600	85 -91	<b>HF</b>
ZX	600 Ninja	85 -87	<b>HF HF</b>
VN	700 Vulcan	85 -85	<b>HF</b>
ZN	700	84 -89	<b>HF HF</b>
	750 Vulcan	93 -94	<b>HF HF</b>
GPZ	750	83 -87	<b>HF HF</b>
GPZ	750 R	85 -86	<b>HF HF</b>
GPZ	750 T	83 -85	<b>HF HF</b>
GT	750	86 -91	<b>HF HF</b>
VN	750 Twin	88 -88	<b>HS</b>
VN	750 Vulcan	86 -94	<b>HF</b>
VZ	750 Twin	88 -88	<b>HF</b>
Z	750	83 -83	<b>HF</b>
Z	750 Eliminator	88 -88	<b>HF HF</b>
Z	750 LTD Twin	83 -85	<b>HF HF</b>
Z	750 Turbo	84 -86	<b>HF HF</b>
ZX	750 E, GP	83 -85	<b>HF HF</b>
VN	800 Vulcan, Classic	95 -97	<b>HS</b>
GPZ	900 R Ninja	84 -89	<b>HF HF</b>
ZL	900 Eliminator	85 -86	<b>HF HF</b>
ZX	900	83 -84	<b>HF HF</b>
GPZ	1000 RX	86 -88	<b>HS LS</b>



<b>KAWASAKI</b>			
GTR	1000	86 -93	<b>HS LS</b>
Z	1000 R Ninja	86 -88	<b>HF HF</b>
ZL	1000	86 -87	<b>HF HF</b>
GPZ	1100	83 -86	<b>HF HF</b>
Z	1100 GP	83 -86	<b>HF HF</b>
Z	1100 LTD	85 -87	<b>HF HF</b>
Z	1100 R, LTD	84 -84	<b>HF HF</b>
ZN	1100 LTD	84 -84	<b>HF HF</b>
ZX	1100 GP	83 -83	<b>HF HF</b>
ZG	1200 Voyager XII	86 -93	<b>HS LS</b>
Z	1300	85 -85	<b>HF HF</b>
ZN	1300	83 -84	<b>HF HF</b>
ZN	1300 Voy.	85 -86	<b>HF HF</b>
VN	1500 Classic	97 -04	<b>LS</b>
VN	1500 Classic Tourer	98 -01	<b>LS</b>
VN	1500 Sumo	88 -92	<b>HF HF</b>
VN	1500 Vulcan	87 -92	<b>HS LS</b>
VN	1500 Vulcan, SE	87 -92	<b>HS LS</b>

STREET HF • HS • LS  
 AMERICAN H.HF • H.CT • H.HS • H.LS  
 SCOOTER HF • CT • MS

RACING  
 OFF ROAD  
 ATV

RST • DC • DCC • DS-1 • DS-2 • RQ  
 SI • RSI • CS  
 ATS • SI • RSI • PSI

Drawings 1:1

Available compounds

HF • HS • LS • RQ

SBS 556

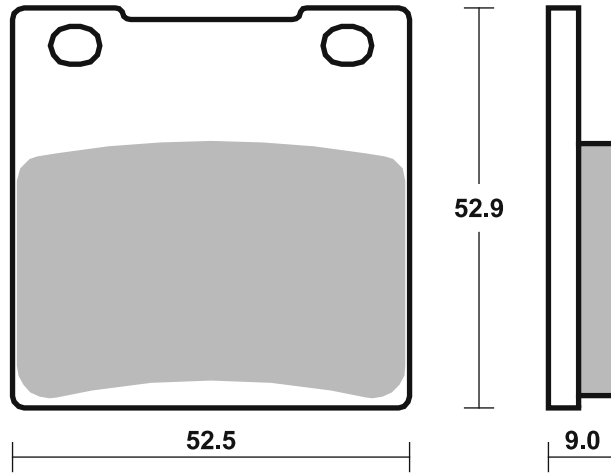

Available compounds

HF • HS • LS

SBS 557

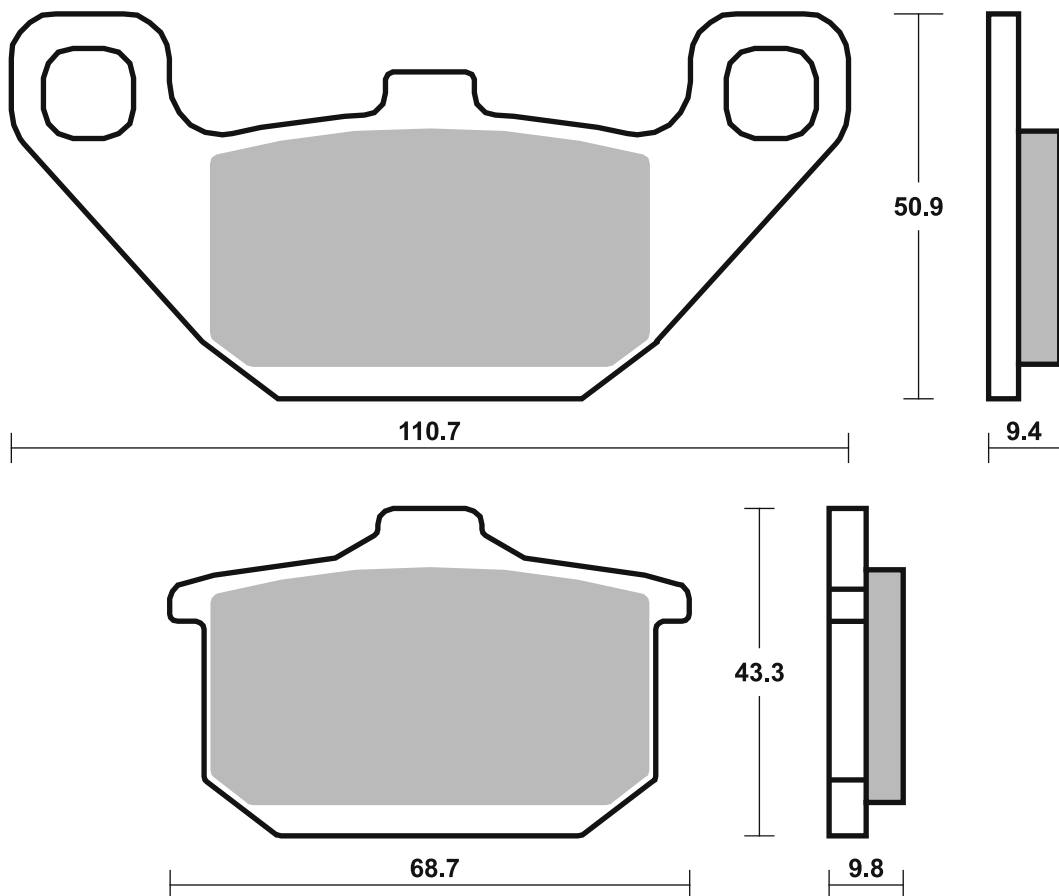

Dimensions in mm / Dimensions en mm  
 1" = 25.4 mm, 1 mm = 0.04"



<b>BENELLI</b>			
TNT	125	17 - 17	HF
<b>HONDA</b>			
MBX	80	86 - 87	HF
MTX	80 R	87 - 87	HF
CR	125 RE, RF	84 - 85	SI
CR	125 RG	86 - 86	SI
MTX	125 R	84 - 95	HF
NSR	125 F	88 - 89	HF
XL	125 R	86 - 86	HF
MTX	200 R	85 - 86	HF
ATC	250 R	85 - 86	SI SI
ATC	250 X	85 - 85	SI
CB	250 RS	85 - 85	HF
CH	250 Spacy	85 - 86	HF
CN	250 Spazio	88 - 89	HF
CR	250 RE, RF	84 - 85	SI
CR	250 RG	86 - 86	SI



<b>HONDA</b>			
FTR	250	86 - 86	HF HF
TRX	250 R	86 - 89	SI
TRX	250 X Fourtrax	87 - 87	SI
XL	250 R	84 - 87	HF
XLR	250 R	88 - 89	SI
XR	250 R	84 - 87	SI
ATC	350 X	85 - 85	SI
XL	350 R	84 - 87	HF
XR	350 R	84 - 85	SI
CR	500 RE, RF	84 - 85	SI
CR	500 RG	86 - 86	SI
XL	500 R	83 - 87	HF
XR	500 R	86 - 86	SI
XR	500 R, Pro Link	83 - 84	HF
XL	600 R	83 - 86	HF
XLM	600 LM	87 - 91	HF
XR	600 R	83 - 87	SI



<b>AJP</b>			
MX	200	09 - 11	HF
<b>ALFER</b>			
MC	80	87 - 87	HF
<b>APRILIA</b>			
TX	240	86 - 88	RSI
	280 R, Climber	92 - 92	RSI RSI
TX	311	86 - 86	RSI
TX	312 M	88 - 88	RSI RSI
TXR	312 M	88 - 88	RSI RSI
<b>BENELLI</b>			
BXK	125	88 - 88	HF
<b>BETA</b>			
	50 Rev	00 - 09	HF HF
	50 Super Trial	92 - 92	HF
ST	50	97 - 97	HF HF
	80 EVO Junior	10 - 11	HF HF
	80 Rev	00 - 07	HF HF
ALP	125	99 - 09	RSI RSI
ALP	125 4-stroke	00 - 05	RSI RSI
SR	125 34	89 - 89	HF
TR	125 34,35	89 - 90	RSI RSI
TRIAL	125	97 - 97	RSI
ALP	200 4-stroke	00 - 05	RSI RSI
	240 Super Trial	92 - 92	RSI
ALP	240	92 - 92	RSI
ALP	240	96 - 96	RSI
	250 Techno	96 - 96	RSI RSI
	250 Zero	91 - 91	RSI
ALP	250	92 - 92	RSI
ALP	250	97 - 03	RSI RSI
	260 Zero	91 - 91	RSI
ALP	260	96 - 96	RSI
TR	260 34,35,ZERO	89 - 92	RSI
<b>BLATA</b>			
	125 Enduro	07 - 08	HF
	125 Motard	07 - 08	HF
<b>CPI</b>			
	125 Supermoto	07 - 12	HF



<b>DERBI</b>			
DS	50	88 - 88	HF
FD	50 Yumbo	84 - 84	HF
FD	50 Yumbo Extra	87 - 87	HF
FDS	50	87 - 87	HF
FDT	50	87 - 87	HF
FDT	50 Coppa	85 - 85	HF
FDX	50	89 - 89	HF
GPR	50 Nude	04 - 10	HF
GPR	50 Racing	04 - 13	HF
	75 GPR	89 - 89	HF
	75 Sport, Coppa	84 - 84	HF
GPR	75 Sport	92 - 92	HF
GPR	80 Cup	04 - 05	HF
	125 Senda R 4T	04 - 12	HF
	125 Senda X-Treme		
	SM 4T	04 - 05	HF
	125 Terra	07 - 07	HF
GP1	125	05 - 06	HF
GPR	125	05 - 06	HF
GPR	125 Nude	05 - 08	HF
GPR	125 Racing	09 - 09	HF
<b>FACTORY</b>			
R12	50 Phantom Agua	06 - 06	RSI
R14	50 Phantom Agua	04 - 04	RSI
R14	50 Phantom Aire	03 - 03	RSI
R2	65 Phantom	04 - 04	RSI
YR	125	06 - 06	HF
<b>FANTIC</b>			
	250 K-Roo	93 - 95	RSI RSI
	305	89 - 90	RSI RSI
	307 Trial	91 - 94	RSI RSI
<b>GAC</b>			
	50 New T.T.	87 - 87	HF
<b>GARELLI</b>			
	50 Ciclone LC, SM	86 - 86	HF
	50 Sahel	91 - 91	HF
<b>GASGAS</b>			
TXT	50 Boy	04 - 04	RSI RSI
	125 Delta	91 - 91	HF



<b>GASGAS</b>			
	125 Pampera	96 - 03	RSI RSI
	125 Trial	91 - 91	RSI
	200 Pampera	99 - 08	RSI RSI
TX	200	97 - 98	RSI RSI
	250 Pampera	96 - 99	RSI RSI
	250 Trial	89 - 96	RSI RSI
GT	250 Contact	92 - 93	RSI RSI
TX	270	97 - 98	RSI RSI
TX	320	97 - 99	RSI RSI
	325 Halley PXC	86 - 86	RSI RSI
	327 Trial	89 - 90	RSI RSI
GT	327 Contact	89 - 90	RSI RSI
	370 Pampera	96 - 00	RSI RSI
<b>GILERA</b>			
	125 Surfer	00 - 00	HF HF
<b>GMA</b>			
	4 Piston front Model F		
<b>HRD</b>			
	125 Supermotard	00 - 02	HF
	125 Trail	00 - 02	HF
<b>HUSQVARNA</b>			
	50 Husky Boy J,		
	R, S	01 - 10	RSI
<b>J. J. COBAS</b>			
TR1	250	85 - 85	HF
Trial	250	85 - 85	RSI
<b>JAYBRAKE</b>			
	2 Piston Dual Series Caliper		
	4 Piston Quad Series Caliper		
<b>JCM</b>			
	125 Europa	89 - 89	RSI RSI
	125 SR	89 - 89	RSI RSI
	240 Europa	89 - 89	RSI RSI
	240 SR	89 - 89	RSI RSI
	325 Europa	89 - 89	RSI RSI
	325 SR	89 - 89	RSI RSI

STREET HF • HS • LS  
AMERICAN H.HF • H.CT • H.HS • H.LS  
SCOOTER HF • CT • MS

RACING  
OFF ROAD  
ATV

RST • DC • DCC • DS-1 • DS-2 • RQ  
SI • RSI • CS  
ATS • SI • RSI • PSI

Drawings 1:1

Available compounds

HF • SI • RSI

SBS 558

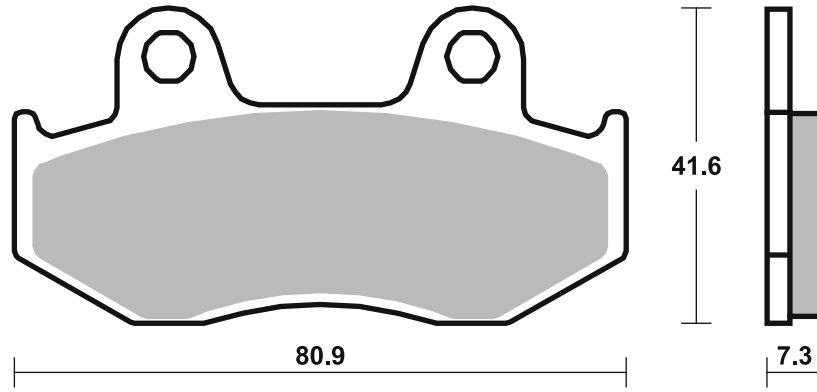

Available compounds

HF • HS • CS • SI • RSI • H.HF • H.CT • H.HS

SBS 559

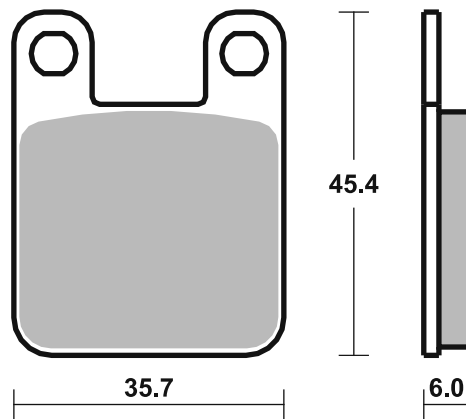

## Applications

### SBS 559

### Recommended compound



<b>KTM</b>			
SX	60	99 - 99	RSI
SX	65	00 - 01	RSI
<b>MACBOR</b>			
XC	50 510 Racing	04 - 04	RSI
XC	50 512 Racing	04 - 04	RSI
XC	50 515 R 6V	04 - 04	RSI
<b>MALAGUTI</b>			
	50 Fifty Evolution	91 - 91	HF
NKD	50 Dragon	06 - 09	HF
<b>MONTESA</b>			
	125 Cota	88 - 88	RSI RSI
	260 Evasion	92 - 92	RSI
	304 Cota	88 - 88	RSI RSI
	307 Cota	89 - 89	RSI RSI
	307 Cota Trial	88 - 89	RSI RSI
	309 Cota	89 - 90	RSI
	310 Cota	89 - 92	RSI
	311 Cota Trial	92 - 92	RSI
	315 Cota R	97 - 04	RSI RSI
	335 Cota	87 - 91	RSI RSI
M7	360 Enduro	85 - 85	HF
<b>MORBIDELLI</b>			
	125 cc	76 - 76	HF HF
<b>MOTORHISPANIA</b>			
RYZ	125 Arena Enduro	05 - 07	HF HF
<b>PERFORMANCE MACHINE</b>			
	125 X 2		
	125 X 4S		
	125 X 4SL		
<b>PEUGEOT</b>			
XPS	125 CT	06 - 07	HF HF
<b>PUCH</b>			
	50 Condor	90 - 90	HF
TZX	50	92 - 92	HF
	75 Cobra	85 - 85	HF



<b>RIEJU</b>			
	50 Drac	97 - 97	HF HF
	50 FD4 Super		
	Marathon	85 - 85	HF
	50 Tangoo	10 - 12	HF
RR	50 , Supermotard	96 - 05	HF HF
RS1	50	92 - 05	HF
RV	50	80 - 80	HF
	75 K6, LC Strada	87 - 87	HF
	75 P6, LC Strada	87 - 87	HF
MR	80 C, E	88 - 90	HF
MR	80 Cross	87 - 87	HF
MR	80 Enduro	87 - 87	HF
RST	80	91 - 93	HF HF
	125 Tango	06 - 12	HF
	125 Tango Pro	08 - 08	HF
MRX	125	03 - 08	HF HF
MRX	125	03 - 08	HF
RR	125	97 - 99	HF HF
RS3	125	10 - 13	HF
SMX	125	03 - 07	HF HF
SMX	125	03 - 07	HF
	250 Tango	08 - 15	HF
<b>SCORPA</b>			
TY-S	115 F Trial	06 - 06	HF
TY-S	125 F Trial	06 - 08	HF
<b>SHERCO</b>			
	80 0.8	01 - 03	HF HF
	125	02 - 02	HF
	125 City Corp 4T		
	Enduro	03 - 07	HF
	125 City Corp 4T SM	03 - 07	HF
ST	125 1.25	01 - 05	HF HF
ST	200 2	01 - 01	HF HF
ST	250	99 - 00	RSI RSI
<b>SIMSON</b>			
	125 SM	01 - 01	HF
<b>SJP</b>			
	2 Piston Caliper (30-375)		
	4 Piston Caliper (30-370)		



<b>SUZUKI</b>			
DR	50 Big	89 - 02	HF
<b>TOMOS</b>			
MC	125 T	06 - 08	HF
SE	125	05 - 08	HF
SM	125 F	06 - 08	HF
<b>YAMAHA</b>			
TY	250 R	91 - 92	HF
TY	250 Z	93 - 96	HF HF

### SBS 560

### Recommended compound



<b>ASPES</b>			
	125 Yuma	76 - 79	HF
<b>BETA</b>			
	125 TS, Custom	83 - 83	HF
<b>CAGIVA</b>			
	650 Alazzurra	85 - 88	HF HF
<b>FANTIC</b>			
	125 Strada	83 - 85	HF
HP1	125 Sport	86 - 86	HF
<b>GARELLI</b>			
GTA	125	86 - 86	HF
TSR	125	83 - 83	HF
<b>GILERA</b>			
	80 TG 1, 2, 3	77 - 82	HF



<b>GILERA</b>			
	125 TG 1, 2, 3		
	(alu wheels)	77 - 85	HF
	125 TG1, GR1, RTX	77 - 85	HF
RV	125	86 - 88	HF
	200 T4, T4C, T4S	79 - 82	HF
<b>GMA</b>			
	2 Piston Caliper, small Model B		
<b>JAYBRAKE</b>			
	2 Piston Caliper ADC/ADCS		
<b>KREIDLER</b>			
	125 Mustang	83 - 87	HF
<b>MOTO-MORINI</b>			
	125 Strada	80 - 80	HF
	250 Strada	80 - 80	HF



<b>MOTO-MORINI</b>			
	350 K2	84 - 87	HF
	350 Strada	76 - 81	HF
	500 Strada	80 - 82	HF
<b>ZUNDAPP</b>			
KS	80 Super	83 - 84	HF
KS	125	79 - 79	HF



STREET HF • HS • LS  
AMERICAN H.HF • H.CT • H.HS • H.LS  
SCOOTER HF • CT • MS

RACING  
OFF ROAD  
ATV

RST • DC • DCC • DS-1 • DS-2 • RQ  
SI • RSI • CS  
ATS • SI • RSI • PSI

Drawings 1:1

Available compounds

HF • HS • CS • SI • RSI • H.HF • H.CT • H.HS

SBS 559

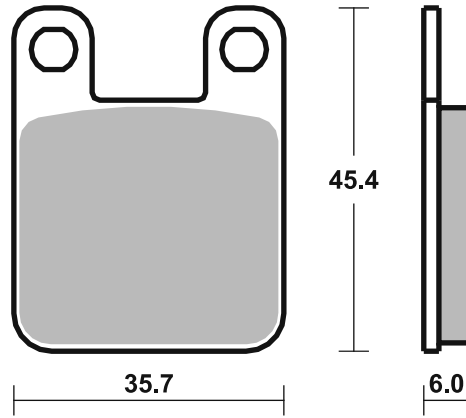

Available compounds

HF • H.HF • H.CT

SBS 560

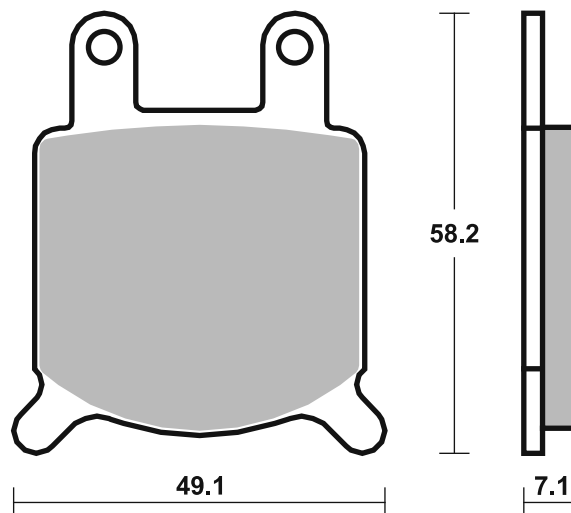

# Applications

## SBS 561 Recommended compound



HONDA			
CB	450 N	84 - 85	HF
CB	450 SC Nighthawk	82 - 82	HF
CB	650 SCC Nighthawk	82 - 82	HF
VT	700 C Shadow	84 - 86	HF
VT	750 C	83 - 85	HF

## SBS 562 Recommended compound



HONDA			
ATC	200 X	83 - 85	SI
ATC	250 R	82 - 84	SI
ATC	250 X	85 - 85	SI
ATC	350 X	85 - 89	SI

## SBS 566 Recommended compound



APRILIA			
RS-4	125 (J.Juan cal.)	11 - 19	HS
RS	250	95 - 96	HF
BETA			
	125 Jonathan	99 - 05	HF
	350 4.0 Motard	04 - 06	RSI
	350 Euro	99 - 03	HF
	350 Jonathan	02 - 03	HF
	350 M4 (Brembo cal.)	06 - 07	HF
BIMOTA			
YB7	400	89 - 89	HF
	500 Vdue	97 - 00	HF
	600 Bellaria	91 - 91	HF
YB9	600 SRI	97 - 97	HF
BB1	650 Supermono	97 - 00	HF
SB7	750	96 - 88	HF



BIMOTA			
YB4	750	89 - 89	HF
1D	851 Tesi	91 - 91	HF
1D	900 Tesi	93 - 93	HF
DB2	900	92 - 00	HF
DB3	900 Mantra	97 - 00	HF
1D	906 Tesi	91 - 91	HF
	1000 Furano	92 - 93	HF
2D	1000 Tesi	04 - 06	HS
YB11	1000	97 - 00	HF
YB6	1000	89 - 89	HF
YB8	1000	90 - 90	HF
	1002 Dieci	91 - 91	HF
SB6	1100	97 - 00	HF
BORILE			
B	500 CR, MT	02 - 04	HF



BREMBO RACING CALIPERS			
	Billet 20.4756.52/62, racing		
	Goldline single pin 20.5165.55/65, road		
BRIXTON			
BX	500 Crossfire	15 - 23	HS
BX	500 X Crossfire	15 - 23	HS
CAGIVA			
	125 Mito	93 - 07	HF
	125 Planet	97 - 07	HF
	125 Raptor	03 - 10	HF
	500 Mito	07 - 07	HS
	500 River	00 - 01	HF
SP	525 Mito	08 - 10	HS
	600 River	94 - 99	HF

Brake Pad 1:1 Drawings, Compounds, Fitments

STREET HF • HS • LS  
 AMERICAN H.HF • H.CT • H.HS • H.LS  
 SCOOTER HF • CT • MS

RACING  
 OFF ROAD  
 ATV

RST • DC • DCC • DS-1 • DS-2 • RQ  
 SI • RSI • CS  
 ATS • SI • RSI • PSI

Drawings 1:1

Available compounds

HF

SBS 561

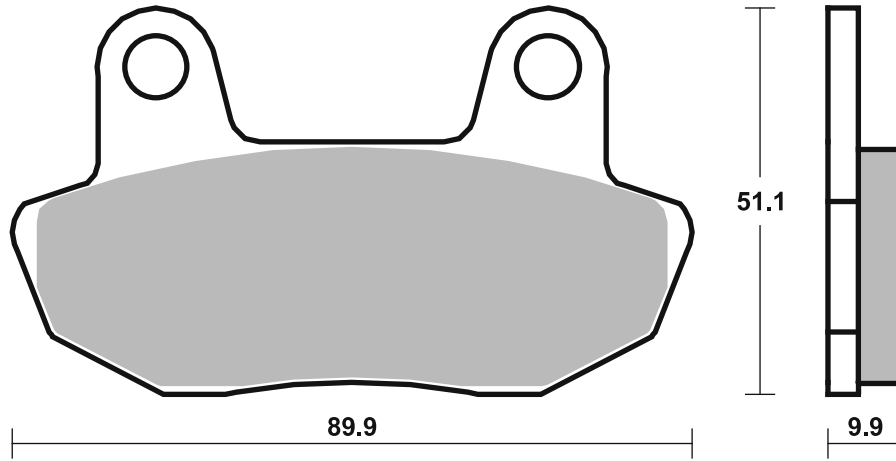

Available compounds

HF • SI • RSI

SBS 562

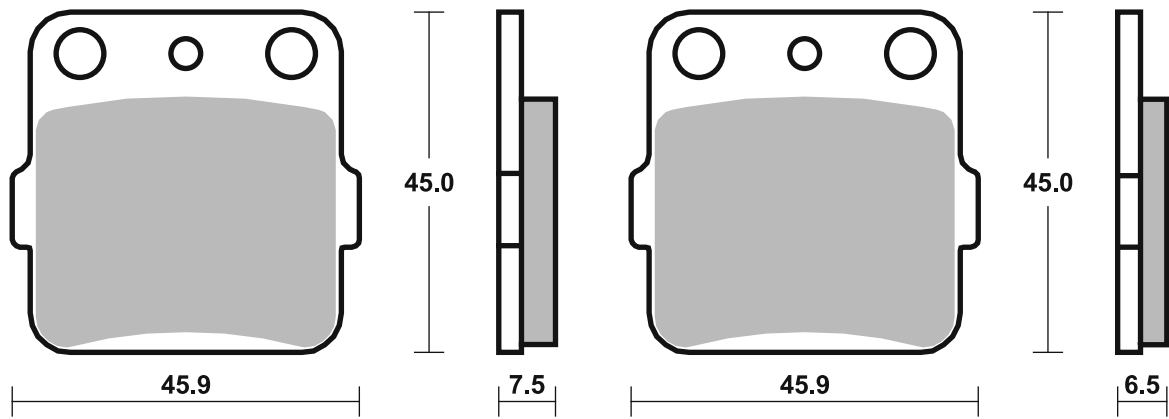

Available compounds

HF • HS • DC • RST • DCC • RSI • H.HF • H.CT • H.HS

SBS 566

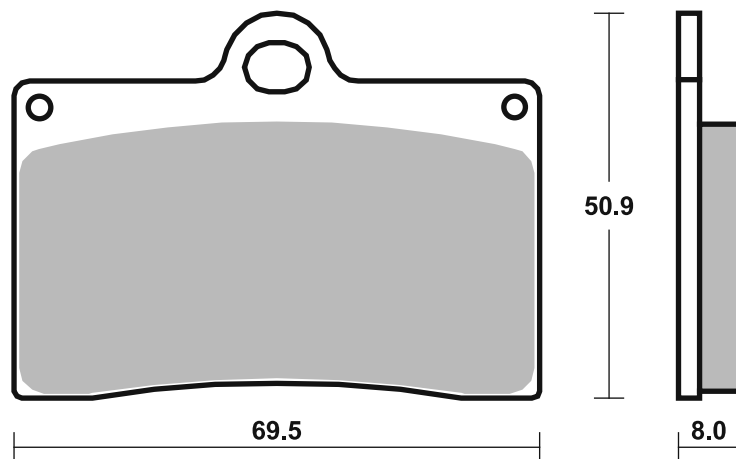



<b>CANNONDALE</b>			
S	440	03 -03	HF
<b>DUCATI</b>			
	400 SS, Junior	92 -97	HF
	400 SS, Nuda	92 -96	HF
	502 Single	93 -93	HF
	502 Supermono	93 -93	HF
	600 SS Supersport	95 -00	HF
M	600 Monster	94 -99	HF
	748 Biposto	95 -98	HF
	748 SP	95 -97	HF
	750 Monster	96 -99	HF
	750 SS	91 -98	HF
	750 SS Supersport	95 -99	HF
	750 SS, Carenara	92 -98	HF
	750 SS, Nuda	92 -92	HF
	750 Super Sport	92 -94	HF
	851 Strada	89 -89	HF
	851 Strada	91 -92	HF
	851 Superbike	90 -90	HF
	888 Roche Replica	91 -91	HF
	888 SP V	93 -93	HF
	888 SP4	92 -95	HF
	888 SPO	93 -93	HF
	888 SPS	92 -95	HF
	888 Strada	93 -93	HF
	888 Superbike	93 -93	HF
	900 FE	97 -98	HF
	900 I. E.	90 -93	HF
	900 M, IL Monster	93 -99	HF
	900 SL	92 -97	HF
	900 SS	90 -94	HF
	900 SS Supersport	95 -97	HF
	900 SSR	92 -92	HF
M	900 Street Monster	94 -99	HF
	916 Biposto	94 -98	HF
<b>FANTIC</b>			
TZ	125 SM	12 -12	HF
<b>GASGAS</b>			
SM	125	02 -13	HF
SM	250	02 -13	HF
SM	400 fse	02 -02	HF
SM	450 fse	03 -06	HF
SM	450 FSR	07 -13	HF
<b>GILERA</b>			
	350 Saturno Bialbero	90 -90	HF
	500 Saturno Bialbero	90 -90	HF
	500 Saturno Piuma	90 -94	HF
<b>HONDA</b>			
RS	125	95 -03	DC
RS	250 R	93 -93	DC
<b>HUSQVARNA</b>			
SM	400 R	02 -02	HF
SM	450 R	03 -04	HF
SM	570 R	01 -08	HF
<b>INDIAN</b>			
	1700 Chief Blackhawk	11 -13	H.HS
	1700 Chief Bomber	10 -13	H.HS
	1700 Chief Classic	10 -13	H.HS
	1700 Chief Dark Horse	10 -13	H.HS
	1700 Chief Deluxe	09 -13	H.HS
	1700 Chief		
	Roadmaster	09 -13	H.HS
	1700 Chief Standard	09 -13	H.HS



<b>INDIAN</b>			
	1700 Chief Vintage	09 -13	H.HS
<b>ITALJET</b>			
	900 Grifon	00 -00	HF
<b>J. J. COBAS</b>			
TR1	250	85 -85	HF
<b>KTM</b>			
	125 Sting	99 -99	HF
SX	450 SM Factory		
	Replica	04 -07	RSI
	600 Duke	93 -94	HF
	620 Duke	96 -98	HF
	640 Duke	99 -02	HF
LC4	640 Supermoto	03 -03	HF
LC4	660 SM Factory		
	Replica	02 -02	RSI
SMC	660 Supermoto	03 -03	HF
<b>LAVERDA</b>			
	650	92 -92	HF
	668 668	96 -97	HF
	668 Ghost, Diamante	97 -97	HF
	750 Cup	98 -01	HF
	750 Diamante	97 -01	HF
	750 Ghost Strike	97 -01	HF
	750 S Formula	97 -01	HF
	750 S, S Carenata	97 -01	HF
	750 Sport	99 -01	HF
	750 Strike/Black		
	Strike	99 -01	HF
	750 T8	98 -01	HF
TTS	800	99 -99	HF
JOTA	1000	95 -95	HF
<b>MOTO-GUZZI</b>			
	750 Ippogrifo	97 -97	HF
	1000 Daytona	91 -02	HF
	1000 Quota	92 -92	HF
RS	1000 Daytona	97 -00	HF
V10	1000 Centauro	96 -00	HF
	1100 California Jackal	00 -00	HF
	1100 California Jackal		
	Basic	00 -00	HF
	1100 California		
	Special	99 -00	HF
	1100 Sport	96 -04	HF
EV	1100 California	97 -00	HF
V11	1100 Sport	97 -00	HF
<b>MZ</b>			
	660 (MUZ)		
	Skorpion Cup	99 -99	HF
	660 (MUZ)		
	Skorpion Replica	97 -99	HF
	660 (MUZ)		
	Skorpion Sport	95 -99	HF
	660 (MUZ)		
	Skorpion Tour	95 -00	HF
	660 (MUZ)		
	Skorpion		
	Traveller	99 -00	HF
<b>NORTON</b>			
F-1	600	90 -90	HF
TT	600	92 -92	HF
<b>PGO</b>			
	250 G-Max	06 -07	HF



<b>REVTECH</b>			
	Wilwood Caliper front/rear		
<b>SACHS</b>			
	125 X-Road	05 -07	HF
XTC	125	99 -07	HF
XTC-N	125	99 -07	HF
	500 MadAss	05 -08	HF
	650 Roadster V1.6	01 -05	HF
	800 B-805	02 -04	HS
	800 Roadster V2	00 -05	HF
	800 S-805	03 -04	HS
<b>TM</b>			
SMR	125	05 -05	RSI
SMF	400 F	02 -02	RSI
SMR	400 F	03 -03	RSI
SMR	450 F	04 -04	RSI
SMX	450 F	03 -03	RSI
SMR	530 F	03 -03	RSI
SMX	600 F	03 -03	RSI
<b>VOR</b>			
SM	400	02 -02	RSI
SM	450	02 -04	RSI
	500 492 Super		
	Motard	00 -01	HF
SM	530	02 -04	RSI
<b>VOXAN</b>			
	1000 Cafe Racer	01 -06	HS
	1000 Roadster	01 -06	HS
<b>YAMAHA</b>			
TZR	250 R	94 -94	HF
SZR	660	96 -01	HF

STREET HF • HS • LS  
AMERICAN H.HF • H.CT • H.HS • H.LS  
SCOOTER HF • CT • MS

RACING  
OFF ROAD  
ATV

RST • DC • DCC • DS-1 • DS-2 • RQ  
SI • RSI • CS  
ATS • SI • RSI • PSI

Drawings 1:1

Available compounds

HF • HS • DC • RST • DCC • RSI • H.HF • H.CT • H.HS

SBS 566

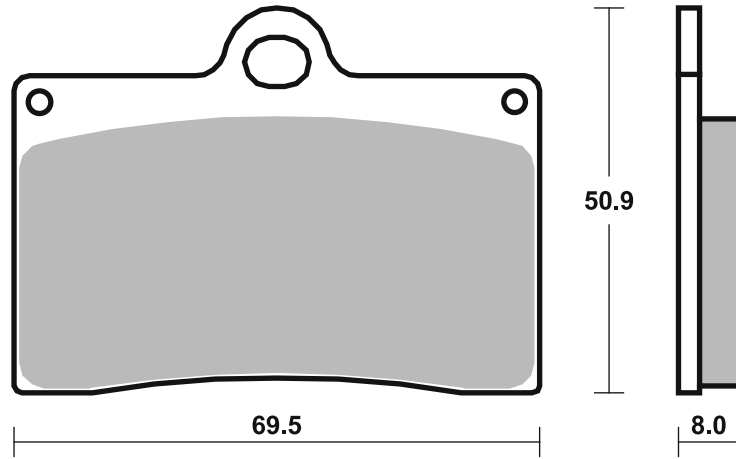



STREET HF • HS • LS  
 AMERICAN H.HF • H.CT • H.HS • H.LS  
 SCOOTER HF • CT • MS

RACING  
 OFF ROAD  
 ATV

RST • DC • DCC • DS-1 • DS-2 • RQ  
 SI • RSI • CS  
 ATS • SI • RSI • PSI

Drawings 1:1

Available compounds

HF • HS • LS • DCC

SBS 570

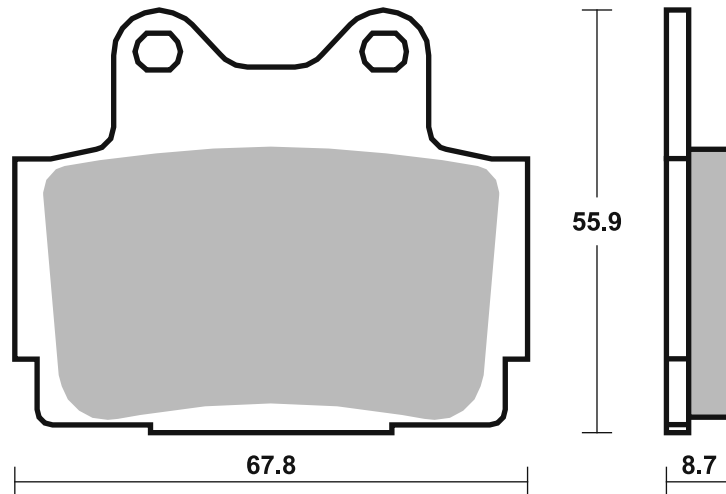

Available compounds

HF

SBS 571

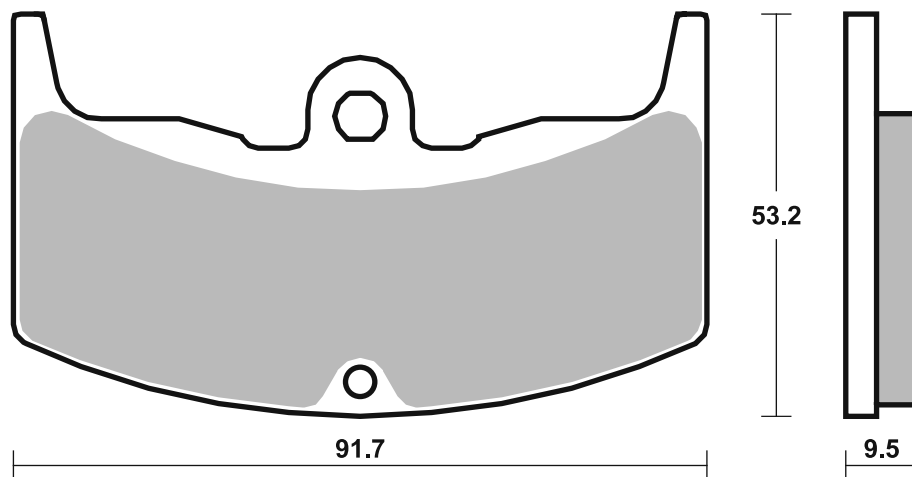

Available compounds

HF • HS • LS • DCC

SBS 572

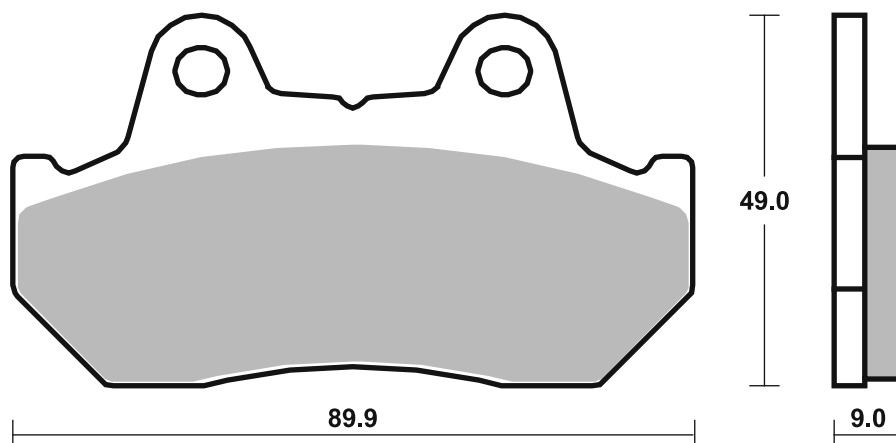

Brake Pad 1:1 Drawings,  
 Compounds, Fitsments

## Applications

### SBS 574

### Recommended compound



<b>APRILIA</b>			
	50 Tuareg	86 -96	HF
	50 Tuareg Rally	90 -96	HF
	125 Strada	85 -85	HF
	125 Tuareg Wind	88 -88	HF
AF1	125	88 -88	HF
	240 Climber	89 -90	HF
	275 Climber	89 -90	HF

<b>BETA</b>			
	350 4.0 Motard	04 -06	RSI
ALP	350 4.0	04 -05	RSI

<b>CAGIVA</b>			
	50 Lucky Explorer	88 -02	HF
	80 Cocis	91 -91	HF
	125 Aletta Electra	83 -86	HF
	125 Aletta Oro	85 -85	HF
	125 Cruiser	89 -89	HF
	125 E2	86 -86	HF
	125 Elefant	81 -88	HF
	125 SST	81 -81	HF
	125 Tamanaco	87 -92	HF
	125 WSTX Aletta		
	Rossa	83 -84	HF
N90	125	91 -98	HF
	200 Aletta Electra	83 -83	HF
	200 Cross	83 -86	HF

<b>FANTIC</b>			
	50 .1 Oasis	87 -87	HF
	50 .1 Raider Rally	87 -87	HF



<b>FANTIC</b>			
	50 Koala	90 -90	HF
	50 Oasis	90 -90	HF
	75 Oasis	89 -89	HF
	125 Raider	83 -85	HF
HP1	125 Sport	87 -87	HF

<b>GARELLI</b>			
	125 Tiger XLE	86 -86	HF

<b>GILERA</b>			
X1	125	89 -89	HF
NGR	250	85 -85	HF

<b>JCM</b>			
	233 Vega	88 -88	HF
	325 Europa	89 -89	RSI
	333 Vega	87 -88	HF

<b>KTM</b>			
SX	65	00 -03	RSI

<b>LAVERDA</b>			
	125 Formula	86 -89	HF
GS	125 Lesmo	86 -94	HF
LB	125 Strada, Sport	85 -85	HF

<b>MALAGUTI</b>			
	50 Evolution	91 -91	HF
ES	50 Dune	89 -89	HF
MDX	50	86 -87	HF
RST	50 Sport	87 -87	HF



<b>MALANCA</b>			
E2	80 C80	80 -80	HF
GTI	80	80 -80	HF
E2	125	80 -84	HF
E2	125 CS ob one 5N,		
	6N, Racing	80 -80	HF
E2	125 Sport	80 -80	HF
GTI	125	80 -80	HF

<b>ZUNDAPP</b>			
KS	80 Super	80 -82	HF

### SBS 575

### Recommended compound



<b>GILERA</b>			
	125 Apache	91 -94	HF
RC	125 Top Rally	90 -93	HF
	250 Oregon Quad	07 -11	SI
RC	600 Top Rally	90 -94	HF

<b>YAMAHA</b>			
YSR	50	87 -92	HF
DT	80 LC-2	85 -92	HF
RD	80 LC	83 -85	HF
TDR	80	89 -89	HF
TZR	80	92 -95	HF
YSR	80	86 -92	HF
DT	125 LC	85 -87	HF
DT	125 R, Electric	88 -03	HF
SR	125 Flame	96 -96	HF
TDR	125 R	93 -03	LS
YBR	125	06 -07	HF
YZ	125	88 -88	RSI
XC	150 Fly One	92 -99	HF
RT	180	95 -96	SI
DT	200	85 -87	HF
DT	200	89 -89	HF
IT	200	85 -85	SI
TT	200	86 -89	HF
	225 Serow	85 -87	HF
TT	225 S,T	86 -00	HF
TT-R	225	01 -04	SI
XT	225	92 -00	HF
XT	225 Serow	86 -86	HF
IT	250	85 -86	SI
TY	250 Z (Scottish)	96 -96	RSI



<b>YAMAHA</b>			
YTZ	250 Tri Moto	85 -86	SI
YZ	250	88 -88	RSI
XT	350	85 -96	HF
YFM	350 XT, XU Warrior	87 -88	SI
YFZ	350 Banshee	87 -89	SI
	400 Artesia	91 -92	LS
XT	400	86 -86	HF
WR	500 B	91 -91	SI
XT	500	86 -89	HF
XT	500 E (Austria)	90 -96	LS
DT	600 N	85 -85	HF
TT	600	85 -88	HF
XT	600 E	90 -03	LS
XT	600 K	91 -94	LS
XT	600 Z, Tenere	87 -90	HF
XTZ	660 Tenere	91 -98	LS



STREET HF • HS • LS  
AMERICAN H.HF • H.CT • H.HS • H.LS  
SCOOTER HF • CT • MS

RACING  
OFF ROAD  
ATV

RST • DC • DCC • DS-1 • DS-2 • RQ  
SI • RSI • CS  
ATS • SI • RSI • PSI

Drawings 1:1

Available compounds

HF • CS • SI • RSI

SBS 574

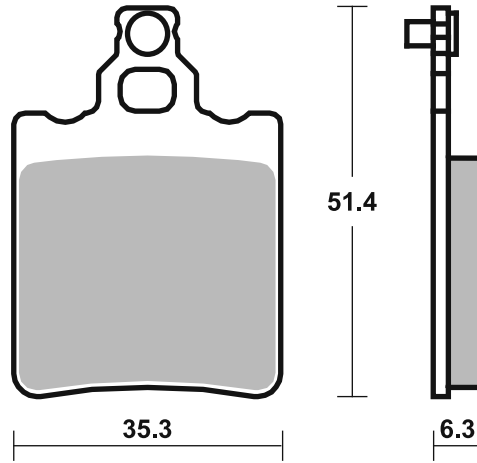

Available compounds

HF • LS • SI • RSI

SBS 575

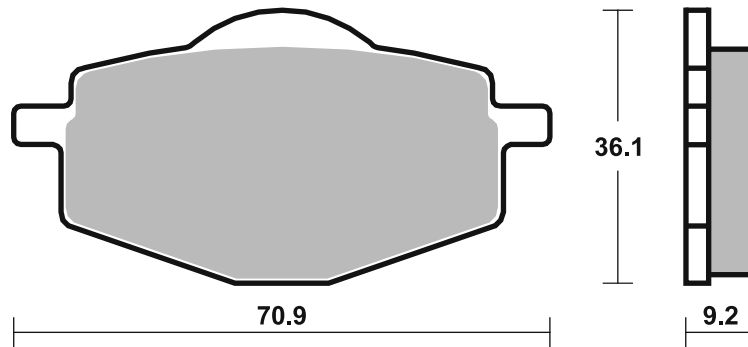



STREET HF • HS • LS  
AMERICAN H.HF • H.CT • H.HS • H.LS  
SCOOTER HF • CT • MS

RACING  
OFF ROAD  
ATV

RST • DC • DCC • DS-1 • DS-2 • RQ  
SI • RSI • CS  
ATS • SI • RSI • PSI

Drawings 1:1

Available compounds

HF • SI • RSI

SBS 576

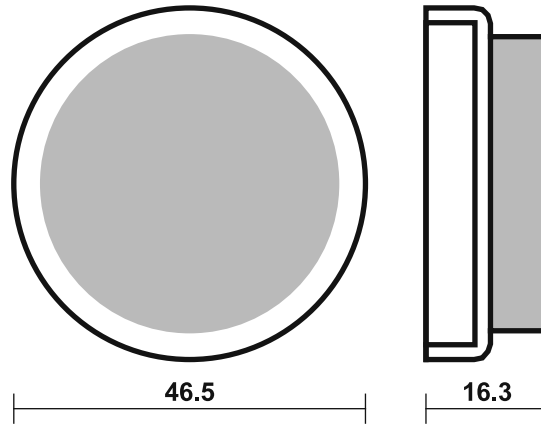

Available compounds

HF • HS • LS • DCC

SBS 577

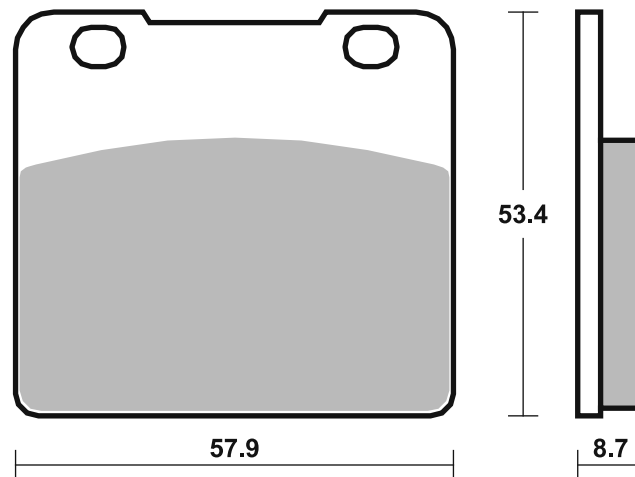

Available compounds

HF

SBS 578

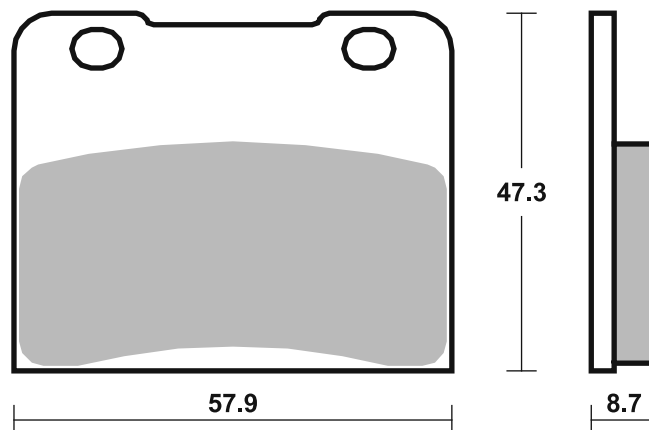

## Applications

### SBS 579

### Recommended compound



HARLEY DAVIDSON			
FLT	Series	88 - 99	<b>H.HS</b>
XLH	Series	88 - 99	<b>H.HS</b>
XLH	883 Sportster	85 - 99	<b>H.HF</b>
XLH	1100	87 - 88	<b>H.HS</b>
XLH	1100 Sportster	85 - 86	<b>H.HF</b>
XLX	1100	86 - 86	<b>H.HF</b>
XLH	1200 Sportster	90 - 99	<b>H.HS</b>
FLHS	1340 Electra Glide Sport	90 - 90	<b>H.HS</b>
FLHT	1340 Electra Glide	85 - 86	<b>H.HF</b>
FLHT	1340 Electra Glide Classic	87 - 99	<b>H.HS</b>
FLHTC	1340 Electra Glide Classic	85 - 86	<b>H.HF</b>
FLHTC	1340 Electra Glide Classic	90 - 99	<b>H.HS</b>
FLHTC	1340 Ultra Classic	90 - 99	<b>H.HS</b>
FLST	1340 Heritage Softail	86 - 87	<b>H.HF</b>
FLST	1340 Heritage Softail	88 - 99	<b>H.HS</b>
FLSTC	1340 Heritage Softail Cl.	90 - 99	<b>H.HS</b>
FLSTF	1340 Fat Boy	90 - 99	<b>H.HS</b>
FLSTN	1340 Heritage Softail Nost.	93 - 99	<b>H.HS</b>
FLT	1340	84 - 85	<b>H.HF</b>
FLT/H	1340 Series	86 - 87	<b>H.HS</b>
FLTC	1340 Tour Glide Classic	85 - 86	<b>H.HF</b>
FLTC	1340 Tour Glide Classic	90 - 90	<b>H.HS</b>
FXDB	1340 Dyna Glide Daytona	91 - 99	<b>H.HS</b>
FXDB	1340 Dyna Glide Sturgis	91 - 99	<b>H.HF</b>
FXDB	1340 Sturgis	91 - 99	<b>H.HS</b>
FXDL	1340 Dyna Low Rider	93 - 99	<b>H.HS</b>
FXDWG	1340 Dyna Wide Glide	93 - 99	<b>H.HS</b>
FXE	1340	85 - 86	<b>H.HF</b>
FXLR	1340 Low Rider Custom	87 - 99	<b>H.HS</b>
FXR	1340	87 - 88	<b>H.HS</b>
FXR	1340 Super Glide	85 - 86	<b>H.HF</b>
FXR	1340 Super Glide	90 - 99	<b>H.HS</b>
FXRD	1340 Sport Glide GTE	85 - 86	<b>H.HF</b>



HARLEY DAVIDSON			
FXRS	1340 Low Rider	85 - 86	<b>H.HF</b>
FXRS	1340 Low Rider Sport	87 - 99	<b>H.HS</b>
FXRS	1340 Low Rider Sport Ed.	90 - 99	<b>H.HS</b>
FXRS	1340 Low Rider, Convert.	90 - 99	<b>H.HS</b>
FXRT	1340 Sport Glide	85 - 86	<b>H.HF</b>
FXRT	1340 Sport Glide	90 - 99	<b>H.HS</b>
FXST	1340 Softail	84 - 86	<b>H.HF</b>
FXSTC	1340 Softail Custom	85 - 86	<b>H.HF</b>
FXSTC	1340 Softail Custom	88 - 99	<b>H.HS</b>
FXSTS	1340 Springer Softail	90 - 99	<b>H.HS</b>
FXWG	1340	87 - 88	<b>H.HS</b>
FXWG	1340 Wide Glide	85 - 86	<b>H.HF</b>
FLSTS/I	1450 Heritage Springer	00 - 03	<b>H.HS</b>
FLSTSC/I	1450 Springer Softail Classic	06 - 06	<b>H.HS</b>
FXSTS/I	1450 Softail	05 - 06	<b>H.HS</b>
FXSTS/I	1450 Springer Softail	00 - 04	<b>H.HS</b>
FLSTSC/I	1584 Softail	07 - 07	<b>H.HS</b>

### SBS 580

### Recommended compound



YAMAHA			
YZ	125	85 - 87	<b>SI</b>
YZ	125	88 - 88	<b>RSI</b>
IT	200	86 - 86	<b>HF</b>
NX	250	88 - 88	<b>HF</b>
TT	250	87 - 92	<b>HF</b>
YZ	250	85 - 87	<b>SI</b>
YZ	250	88 - 88	<b>RSI</b>
TT	350	86 - 87	<b>SI</b>
YZ	490	85 - 90	<b>SI</b>
TT	600	90 - 92	<b>HF</b>

STREET HF • HS • LS  
 AMERICAN H.HF • H.CT • H.HS • H.LS  
 SCOOTER HF • CT • MS

RACING  
 OFF ROAD  
 ATV

RST • DC • DCC • DS-1 • DS-2 • RQ  
 SI • RSI • CS  
 ATS • SI • RSI • PSI

Drawings 1:1

Available compounds

H.HF • H.CT • H.HS

SBS 579

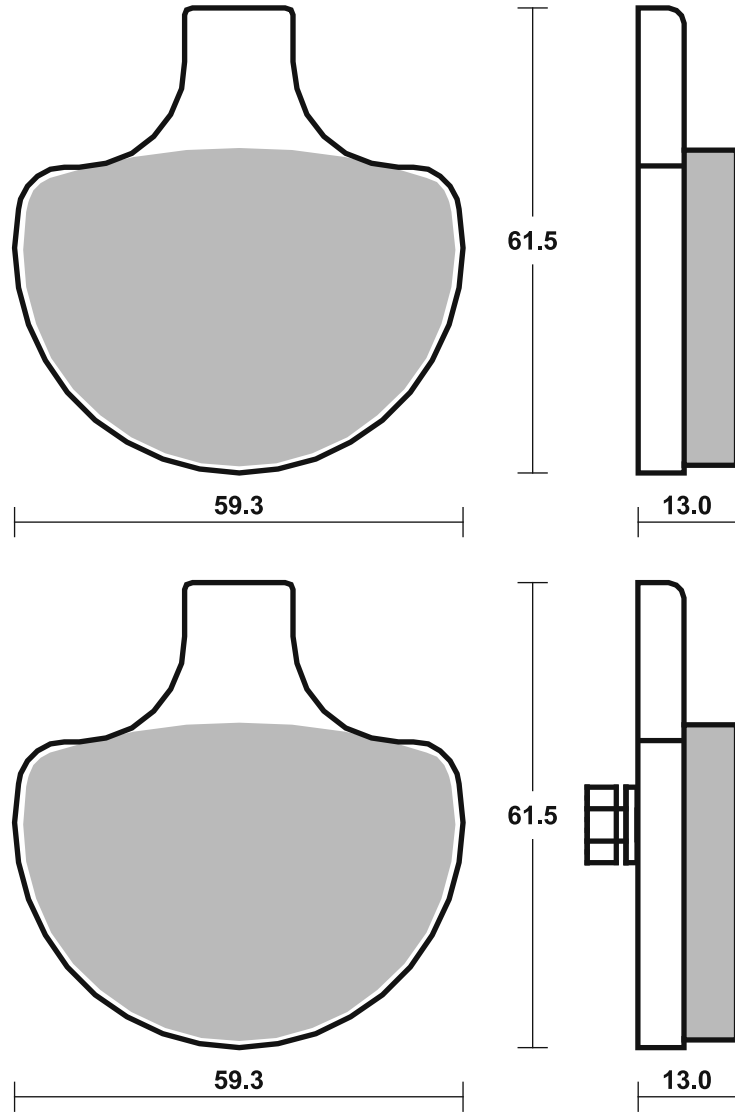

Available compounds

HF • SI • RSI

SBS 580

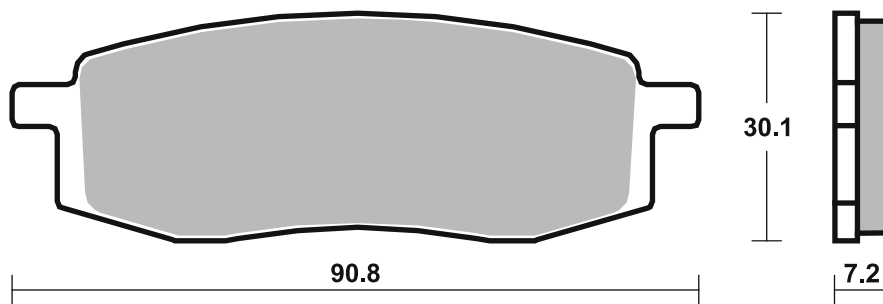

# Applications

## SBS 581 Recommended compound



<b>MAICO</b>			
GM	250 Star	86 - 86	HF HF
GP	250 E	87 - 87	HF HF
GP	250 Motocross	87 - 87	HF HF
GP	400 E	87 - 88	HF HF
GP	400 Motocross	87 - 88	HF HF
GM	500 Star	86 - 86	HF HF
GP	500 E	87 - 87	HF HF
GP	500 Motocross	87 - 87	HF HF
GP	550	87 - 87	HF HF
<b>SUZUKI</b>			
GZ	125 Marauder	00 - 11	HF
RM	125	85 - 86	HF
VL	125 Intruder LC	00 - 08	HF
GZ	250 Marauder	00 - 08	HF
RM	250	85 - 85	HF
TU	250 X Super Classic	97 - 00	HF
VL	250 Intruder	00 - 07	HF



<b>SUZUKI</b>			
LS	400 Savage	87 - 91	HF
RM	500	85 - 87	HF
LS	650	05 - 05	HF
LS	650 P	86 - 88	HF
LS	650 P Savage	95 - 04	HF

## SBS 582 Recommended compound



<b>SUZUKI</b>			
RM	250	86 - 86	HF
DR	500	89 - 89	HF
DR	600 Djebel	86 - 88	HF
DR	600 S Dakar	85 - 87	HF
SP	600 F	85 - 87	HF

## SBS 583 Recommended compound



<b>KTM</b>			
MX	80	86 - 92	HF

Brake Pad 1:1 Drawings, Compounds, Fitments

STREET HF • HS • LS  
 AMERICAN H.HF • H.CT • H.HS • H.LS  
 SCOOTER HF • CT • MS

RACING  
 OFF ROAD  
 ATV

RST • DC • DCC • DS-1 • DS-2 • RQ  
 SI • RSI • CS  
 ATS • SI • RSI • PSI

Available compounds

HF

SBS 581

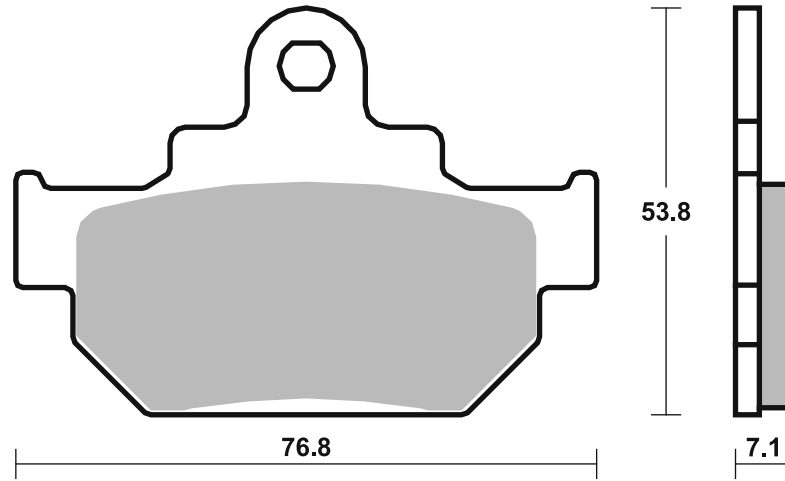

Available compounds

HF

SBS 582

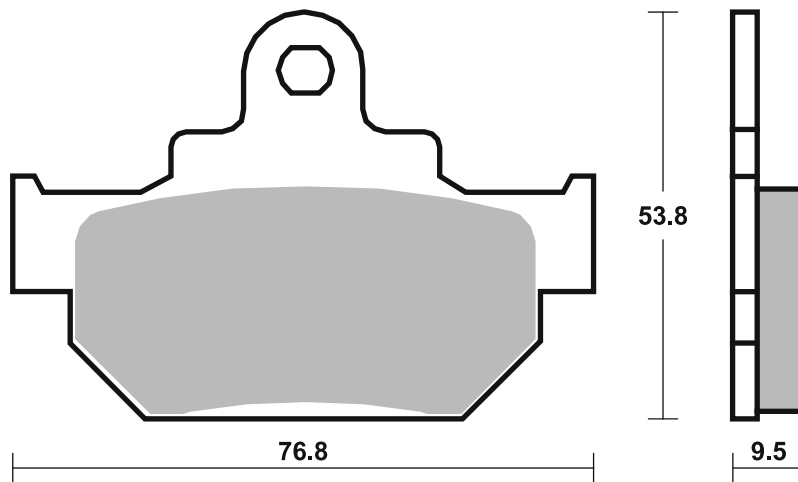

Available compounds

HF

SBS 583

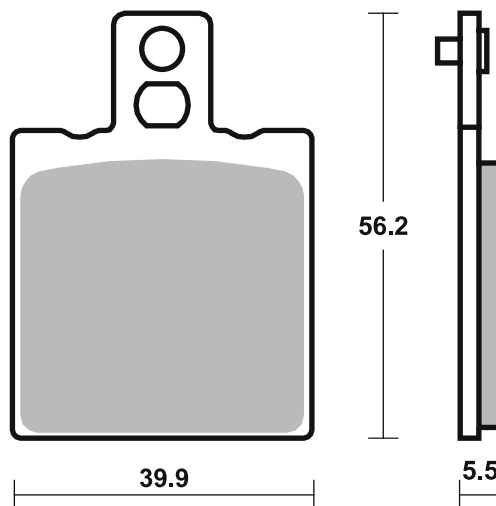





STREET HF • HS • LS  
 AMERICAN H.HF • H.CT • H.HS • H.LS  
 SCOOTER HF • CT • MS

RACING  
 OFF ROAD  
 ATV

RST • DC • DCC • DS-1 • DS-2 • RQ  
 SI • RSI • CS  
 ATS • SI • RSI • PSI

Drawings 1:1

Available compounds

HF • SI • RSI

SBS 584

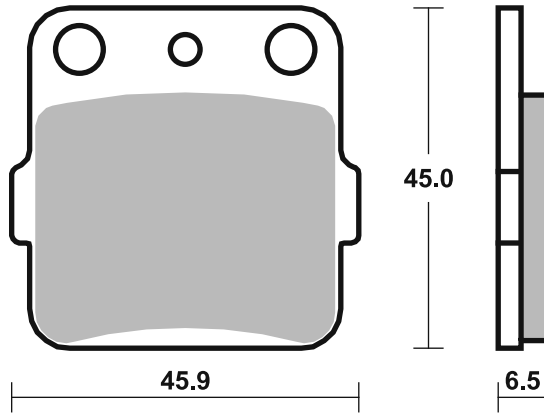

Available compounds

HF

SBS 585

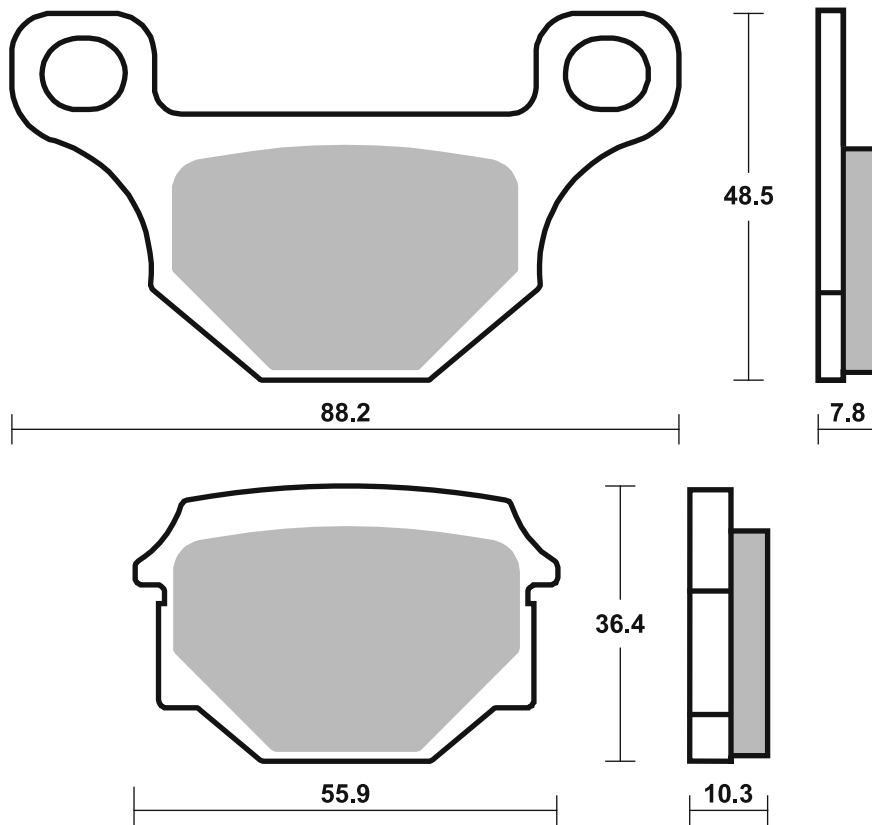



STREET HF • HS • LS  
 AMERICAN H.HF • H.CT • H.HS • H.LS  
 SCOOTER HF • CT • MS

RACING  
 OFF ROAD  
 ATV

RST • DC • DCC • DS-1 • DS-2 • RQ  
 SI • RSI • CS  
 ATS • SI • RSI • PSI

Drawings 1:1

Available compounds

HF • LS • SI • RSI

SBS 586

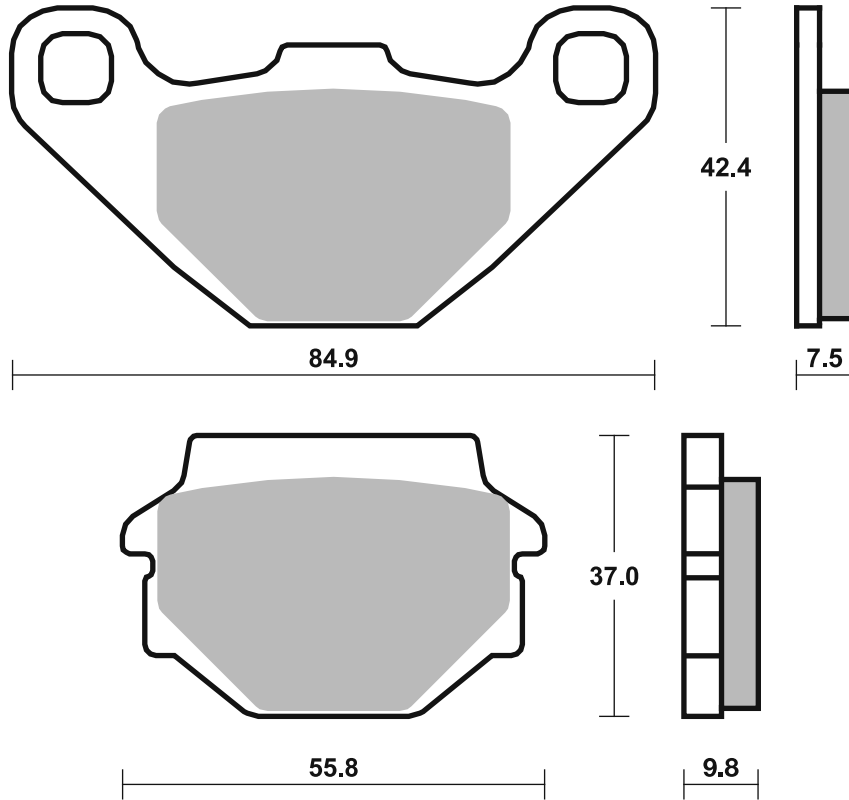

Available compounds

HF

SBS 587

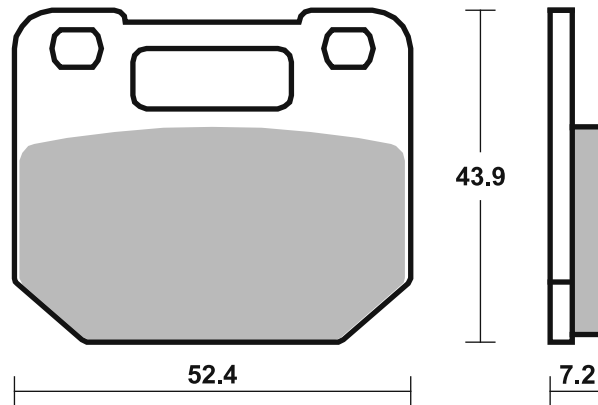



APRILIA			
	125 Red Rose	89 - 89	HF
	125 Tuareg	86 - 86	HF
ETX	125	84 - 86	HF
ETX	125 Tuareg	86 - 87	HF
MX	125 Cross	85 - 85	HF
	250 Tuareg Rally	86 - 86	HF
	350 Tuareg	86 - 86	HF
	350 Tuareg Wind	87 - 87	HF
ETX	350	85 - 86	HF
	600 Tuareg	86 - 87	HF
ETX	600	86 - 92	HF
NA	850 Mana GT, ABS	09 - 13	HF
NA	850 Mana, ABS	08 - 11	HF

CAGIVA			
	125 Blues	87 - 85	HF
	125 Roadster	94 - 97	HF
	200 Roadster	96 - 01	HF

FANTIC			
	250 Raider	85 - 85	HF

GARELLI			
	125 Tiger XLE	86 - 86	HF

GILERA			
	125 Fast Bike	88 - 89	HF
	125 KK, KR, KZ	86 - 91	HF
	125 R1, R1S	90 - 92	HF
ER	125 Rally	87 - 87	HF
MXR	125	90 - 90	HF
RRT	125 Nebraska	87 - 87	HF
RTX	125	86 - 86	HF
RX	125 Arizona Hawk	85 - 85	HF
X1	125	89 - 89	HF
XR2	125	90 - 90	HF
	200 Arizona Hawk	85 - 85	HF
	200 ER	87 - 87	HF
	200 Fast Bike	87 - 87	HF



GILERA			
	250 Arizona Rally	08 - 08	HF
	350 Dakota	85 - 85	HF
XRT	350	90 - 90	HF
	500 Dakota	86 - 86	HF
RC	600	88 - 88	HF
XRT	600	89 - 89	HF

HONDA			
CA	125 Rebel	97 - 00	HF
CLR	125 Cityfly	99 - 03	HF
CRM	125 , R	90 - 98	HF
MTX	125 Camel, Italy	88 - 98	HF
MTX	125 R, Italy	86 - 86	HF
NS	125 Italy	85 - 88	HF
NSR	125 F, R	90 - 92	HF
NSR	125 R, Italy	89 - 01	HF
NX	125 , Transcity	90 - 98	HF
RTV	125 NRS, Italy	87 - 87	HF
XL	125 R, P.D., Italy	85 - 85	HF
XL	125 R, P.D., Italy, EX	87 - 87	HF
XL	200 R, P.D., Italy	85 - 85	HF

MOTO-GUZZI			
V7	750 Racer	12 - 14	HF
V7	750 Stone	12 - 14	HF
V7 II	750 Racer	15 - 16	HF
V7 II	750 Scrambler	16 - 16	HF
V7 II	750 Special	15 - 16	HF
V7 II	750 Stone	15 - 16	HF
V7 II	750 Stornello	16 - 16	HF
V7 II	750 Stornello Ltd.		
	Edition	17 - 18	HF
V7 III	750 Anniversario	17 - 18	HF
V7 III	750 Carbon	18 - 19	HF
V7 III	750 Euro 4	17 - 19	HF
V7 III	750 Limited	19 - 19	HF
V7 III	750 Milano	18 - 20	HF
V7 III	750 Racer	17 - 20	HF
V7 III	750 Rough	18 - 20	HF



MOTO-GUZZI			
V7 III	750 Special	17 - 19	HF
V7 III	750 Stone	17 - 20	HF
V7	850 Special	22 - 23	HF
V7	850 Stone	22 - 23	HF
V7	850 Stone Fast		
	Endurance	22 - 22	HF
V7	850 Stone Special		
	Edition	23 - 23	HF
V85	850 TT	19 - 23	HF
V85	850 TT Evocative		
	Graphics	23 - 23	HF
V85	850 TT Guardia		
	d'Onore	22 - 23	HF
V85	850 TT Travel	20 - 23	HF
V9	850 Bobber	16 - 17	HF
V9	850 Bobber Sports	19 - 20	HF
V9	850 Roamer	16 - 17	HF
V9	850 X-Track	17 - 17	HF

MOTO-MORINI			
	350 Excalibur	87 - 89	HF
	350 Kanguro	88 - 88	HF
	501 Camel	88 - 88	HF
RLX	501 Excalibur	87 - 87	HF

SACHS			
	125 Roadster V2	01 - 01	HF
ZX	125	99 - 02	HF
ZZ	125	99 - 02	HF

SIMSON			
	125	01 - 01	HF
	125 RS	01 - 01	HF



YAMAHA			
YZ	65	19 - 24	RSI
YZ	80	86 - 92	SI
YZ	80	93 - 01	RSI
YZ	85	02 - 24	RSI
TT-R	125 LW	00 - 24	SI

STREET HF • HS • LS  
AMERICAN H.HF • H.CT • H.HS • H.LS  
SCOOTER HF • CT • MS

RACING  
OFF ROAD  
ATV

RST • DC • DCC • DS-1 • DS-2 • RQ  
SI • RSI • CS  
ATS • SI • RSI • PSI

Drawings 1:1

Available compounds

HF

SBS 588

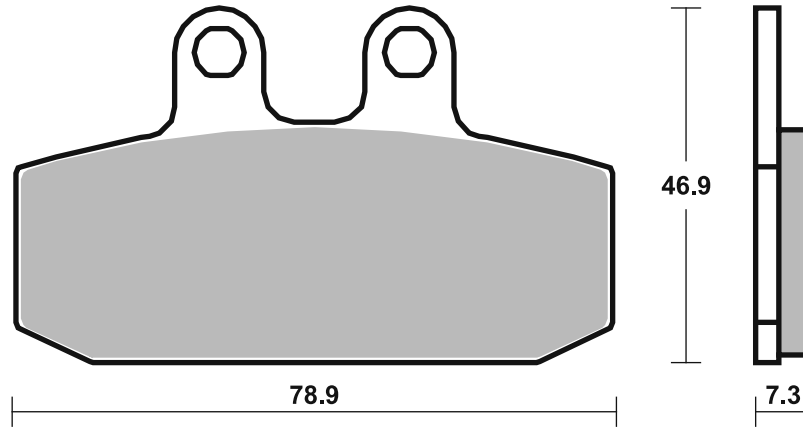

Available compounds

HF • CS • SI • RSI

SBS 589

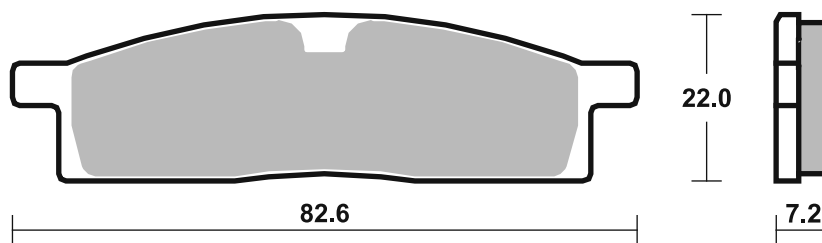



STREET HF • HS • LS  
 AMERICAN H.HF • H.CT • H.HS • H.LS  
 SCOOTER HF • CT • MS

RACING  
 OFF ROAD  
 ATV

RST • DC • DCC • DS-1 • DS-2 • RQ  
 SI • RSI • CS  
 ATS • SI • RSI • PSI

Drawings 1:1

Available compounds

HF • HS • LS • DCC

SBS 590

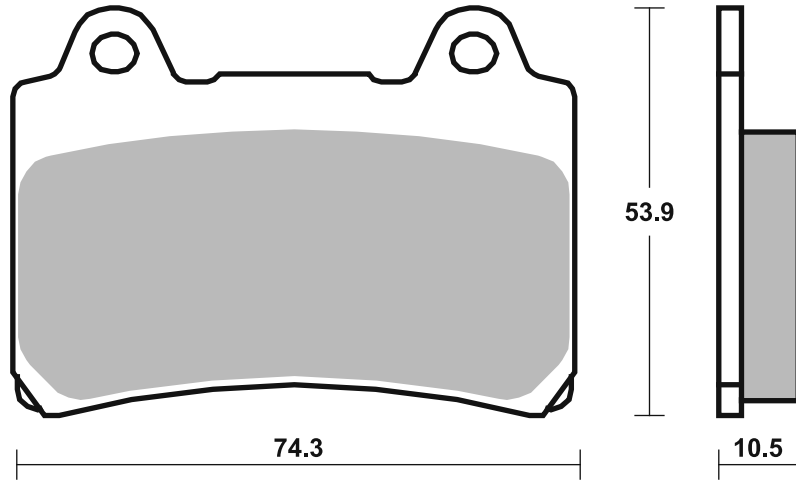

Available compounds

HF • SI • RSI

SBS 591

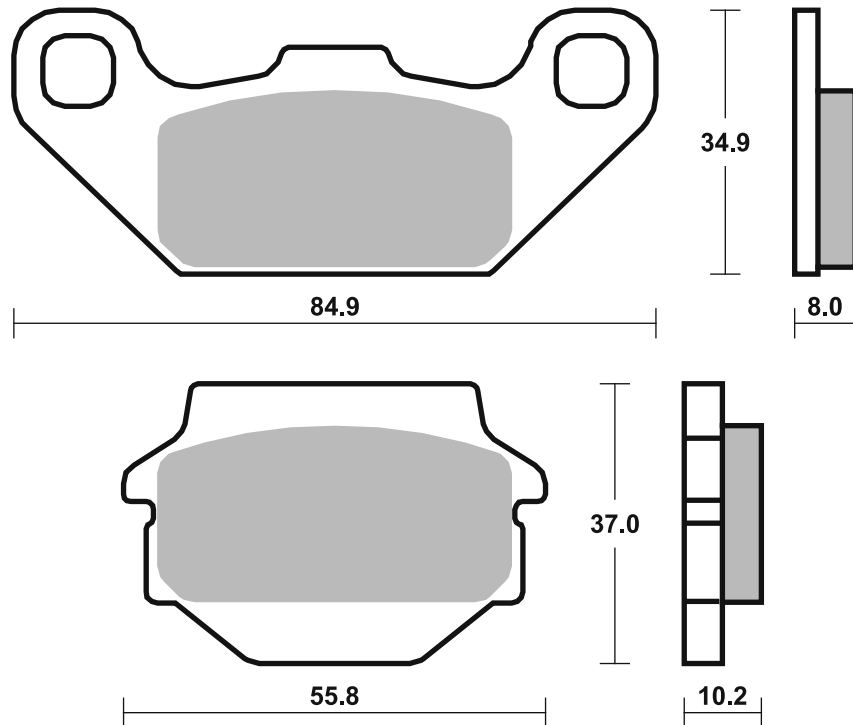

## Applications

### SBS 592

#### Recommended compound



<b>ARCTIC CAT</b>			
400 DVX	04 - 08	SI	
<b>HONDA</b>			
CR 85 R, R Expert	03 - 12	RSI	
CRF 150 R	07 - 24	RSI	
ATC 200 X	83 - 85	SI	
ATC 200 X	86 - 87	SI	SI
TRX 250 EX Sportrax	01 - 08	SI	
TRX 250 X	08 - 13	SI	
TRX 300 EX Sportrax	01 - 08	SI	SI
TRX 300 X	09 - 09	SI	SI
TRX 400 EX Sportrax	01 - 08	SI	SI
TRX 400 Fourtrax EX	99 - 00	SI	SI
TRX 400 X	09 - 12	SI	SI
TRX 420 FA / FPA	09 - 13	SI	
TRX 420 FPE / FPM 4x4	09 - 14	SI	
TRX 450 EX Sportrax	01 - 05	SI	SI
<b>KAWASAKI</b>			
KX 80	88 - 00	RSI	
KX 85	01 - 24	RSI	
KX 85 II	01 - 24	RSI	



<b>KAWASAKI</b>			
KX 100	88 - 21	RSI	
KLX 140 , L	08 - 24	SI	
KSF 250 Mojave	87 - 02	SI	
KXF 250 Tecate	87 - 88	SI	
KXT 250 Tecate	87 - 88	SI	
KEF 300 Lakota	95 - 04	SI	
KFX 400	02 - 05	SI	
KFX 450	07 - 15	SI	
<b>SUZUKI</b>			
RM 100	03 - 03	RSI	
LT 230	86 - 93	SI	
LT 250	89 - 90	SI	
LT-Z 400 Quad Sport	02 - 19	SI	
RM 500	88 - 89	RSI	
DR-Z 800	88 - 90	LS	
<b>TM</b>			
80 Junior	96 - 00	RSI	
<b>YAMAHA</b>			
YZ 65	19 - 24	RSI	



<b>YAMAHA</b>			
YZ 80	93 - 01	RSI	
YZ 85	02 - 24	RSI	
YFS 200 R Blaster	03 - 06	SI	
YFM 250 Raptor	09 - 14	SI	
YFM 350 FXG-FXM			
	Wolverine	95 - 11	SI
YFM 350 R Raptor	04 - 14	SI	SI
YFM 350 XG,XH Warrior	95 - 96	SI	
YFM 350 XT, XU Warrior	87 - 88	SI	
YFZ 350 Banshee	87 - 06	SI	
YFZ 450 S	04 - 05	SI	
YFM 600 4x4 Grizzly	98 - 01	SI	
YFM 660 FWAP 4x4			
	Grizzly	02 - 08	SI
YFM 660 RN Raptor	01 - 09	SI	SI

### SBS 593

#### Recommended compound



<b>HONDA</b>			
CBR 250 F	86 - 86	HF	
CBR 250 Hurricane	87 - 87	HF	
NSR 250 R	87 - 87	HF	
VT 250 F	88 - 90	HF	
VTR 250	90 - 90	HS	
VTZ 250	88 - 99	HF	
CB 350 S.G. (U.K. only)	87 - 90	HF	
NX 350	88 - 99	HF	
CB 400 N	86 - 86	HF	
CBR 400 F	92 - 96	HS	
CBR 400 R	87 - 87	HF	
VFR 400 R	86 - 86	HF	HF
VFR 400 R	87 - 88	HS	
CB 450 S	86 - 88	HF	



<b>HONDA</b>			
CBR 500 F (Austria)	87 - 90	HS	
CBR 600 F Hurricane	87 - 90	HS	
CBR 600 F, Super Sport	91 - 94	HS	
NTV 600 Revere	88 - 92	HF	
XRV 750 Africa Twin	90 - 92	HS	

### SBS 594

#### Recommended compound



<b>APRILIA</b>			
350 Tuareg Wind	88 - 88	HF	
600 Tuareg Wind	88 - 88	HF	
<b>CAGIVA</b>			
125 Cruiser	88 - 88	HF	
350 Elephant	86 - 89	HF	
650 Elephant	86 - 87	HF	
750 Elephant Bifaro	90 - 90	HF	
750 Lucky Explorer	88 - 88	HF	
<b>DUCATI</b>			
350 Indiana	86 - 91	HF	
650 Indiana	86 - 89	HF	
750 Indiana	85 - 86	HF	
<b>GILERA</b>			
350 Dakota	86 - 89	HF	



<b>LAVERDA</b>			
OR 600 Atlas	86 - 90	HF	
<b>MOTO-MORINI</b>			
350 Excalibur	86 - 86	HF	HF
350 Indiana	88 - 88	HF	
501 New York	89 - 89	HF	
RLX 501 Excalibur	86 - 86	HF	HF
RLX 501 Excalibur	88 - 89	HF	
650 Indiana	88 - 88	HF	
750 Indiana	88 - 88	HF	



STREET HF • HS • LS  
 AMERICAN H.HF • H.CT • H.HS • H.LS  
 SCOOTER HF • CT • MS

RACING  
 OFF ROAD  
 ATV

RST • DC • DCC • DS-1 • DS-2 • RQ  
 SI • RSI • CS  
 ATS • SI • RSI • PSI

Drawings 1:1

Available compounds

HF • LS • CS • SI • RSI

SBS 592

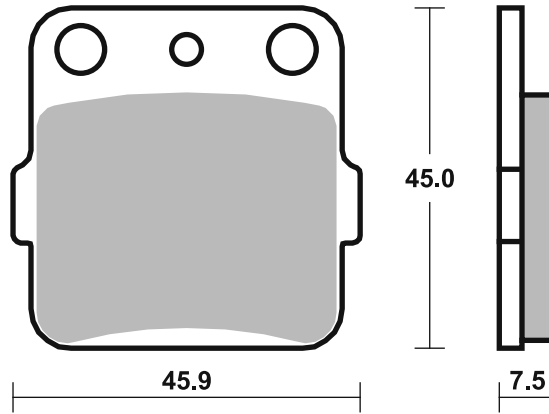

Available compounds

HF • HS • RST • DCC • RQ

SBS 593

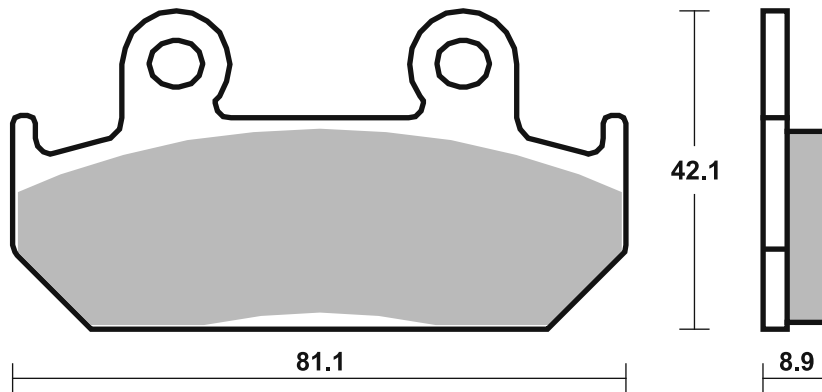

Available compounds

HF

SBS 594

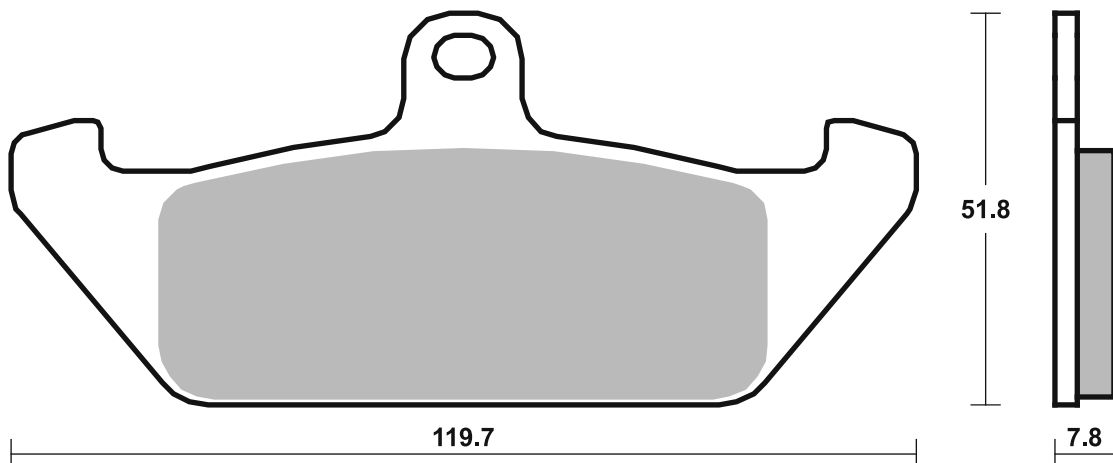

Brake Pad 1:1 Drawings,  
 Compounds, Fitments

## Applications

**SBS 595**

**Recommended compound**



<b>BENELLI</b>			
50 Devil	92 - 92		<b>HF</b>
50 Spring	92 - 92		<b>HF</b>
<b>BETA</b>			
AE 50 Four Twin	88 - 88		<b>HF</b>
ALP 50	91 - 00		<b>HF</b>
RV 50	88 - 88		<b>HF</b>
VRS 50	86 - 86		<b>HF</b>
ALP 125	90 - 90		<b>HF</b>
TR 125 32,33	86 - 87		<b>HF</b>
TR 125 34	88 - 88		<b>HF</b>
TR 240 33	86 - 88		<b>HF</b>
TR 260 Synt	92 - 92		<b>HF</b>
TR 260 34	86 - 88		<b>HF</b>
<b>FANTIC</b>			
50 Trial	83 - 83		<b>HF</b>
125 Trial	78 - 84		<b>HF</b>
125 Trial Professional	87 - 87		<b>HF</b>
125 Trial Progress 1	87 - 87		<b>HF</b>
HP1 125 Strada	85 - 85		<b>HF</b>
201 Trial	85 - 91		<b>HF</b>
201 Trial Progress 2	87 - 87		<b>HF</b>
241 Trial Progress 2	87 - 87		<b>HF</b>
243 Trial	87 - 90		<b>HF</b>
301 Trial	85 - 91		<b>HF</b>
301 Trial Progress 2	87 - 87		<b>HF</b>
303 Trial Professional	87 - 87		<b>HF</b>
343 Trial Progress 2	87 - 87		<b>HF</b>



<b>GARELLI</b>			
323 Trial	86 - 86		<b>HF</b>
<b>GILERA</b>			
50 Bullit	90 - 97		<b>HF</b>
<b>JCM</b>			
125 Oxygene	89 - 89		<b>HF</b>
125 Week-End	89 - 89		<b>HF</b>
233 Vega	88 - 88		<b>HF</b>
240 Enduro	91 - 91		<b>HF</b>
240 Oxygene	89 - 89		<b>HF</b>
240 Week-End	89 - 89		<b>HF</b>
250 Trial	87 - 87		<b>HF</b>
250 Week-End	91 - 91		<b>HF</b>
325 Oxygene	89 - 89		<b>HF</b>
325 Week-End	89 - 89		<b>HF</b>
333 Vega	87 - 88		<b>HF</b>
<b>MALAGUTI</b>			
50 Fifty Full, CX, Top	85 - 85		<b>HF</b>
50 Fifty Mistral	90 - 95		<b>HF</b>
CH 50	86 - 86		<b>HF</b>
MGX 450 Ronco	87 - 11		<b>HF</b>
<b>MONTESA</b>			
H7 360 Enduro	86 - 86		<b>HF</b>
<b>RIEJU</b>			
50 Drag	92 - 92		<b>HF</b>
RS1 50	92 - 05		<b>HF</b>



<b>TOMOS</b>			
BT 50 S	89 - 89		<b>HF</b>
N 50 AT, BT	91 - 95		<b>HF</b>
CTX 80	89 - 89		<b>HF</b>

**SBS 596**

**Recommended compound**



<b>MALAGUTI</b>			
MDX 50 Gold Enduro	87 - 87		<b>HF</b>
MLX 50 Enduro	87 - 87		<b>HF</b>
<b>MOTO-GUZZI</b>			
NTX 750	90 - 93		<b>HS</b>
<b>YAMAHA</b>			
RT 180	90 - 93		<b>HF</b>
TT 600	89 - 89		<b>HF</b>
XT 600 Z	86 - 88		<b>HF</b>
XT 600 Z, Tenere	87 - 90		<b>HF</b>

STREET HF • HS • LS  
AMERICAN H.HF • H.CT • H.HS • H.LS  
SCOOTER HF • CT • MS

RACING  
OFF ROAD  
ATV

RST • DC • DCC • DS-1 • DS-2 • RQ  
SI • RSI • CS  
ATS • SI • RSI • PSI

Drawings 1:1

Available compounds

HF

SBS 595

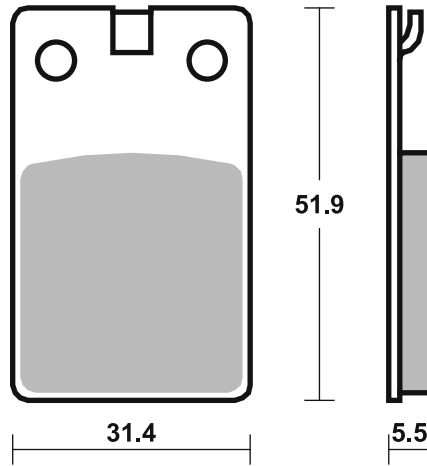

Available compounds

HF • HS

SBS 596

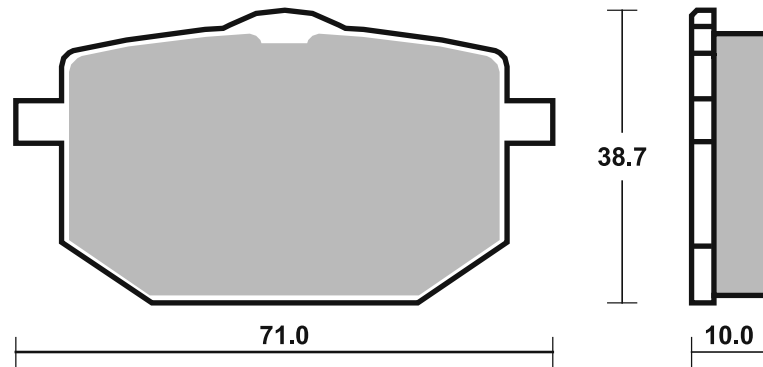



STREET HF • HS • LS  
 AMERICAN H.HF • H.CT • H.HS • H.LS  
 SCOOTER HF • CT • MS

RACING  
 OFF ROAD  
 ATV

RST • DC • DCC • DS-1 • DS-2 • RQ  
 SI • RSI • CS  
 ATS • SI • RSI • PSI

Drawings 1:1

Available compounds

HF • HS • LS • RQ

SBS 597

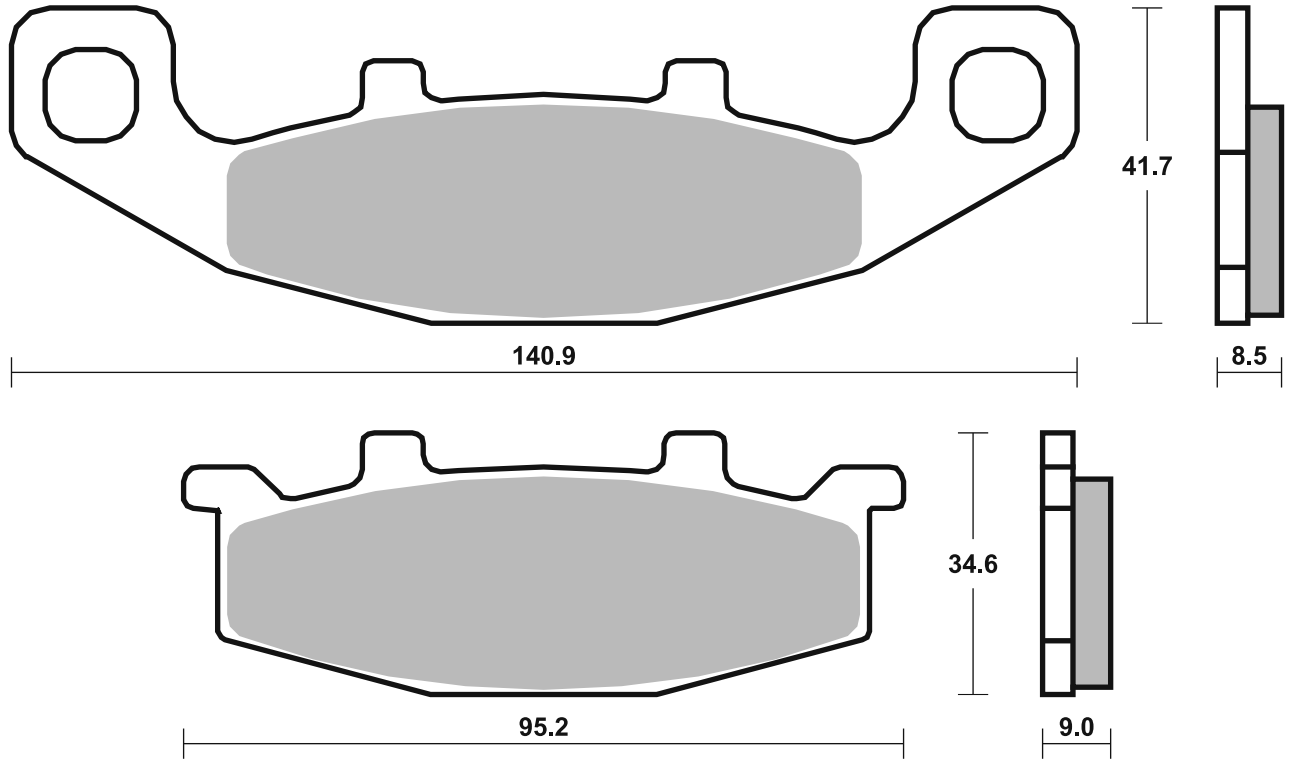

Available compounds

HF

SBS 598

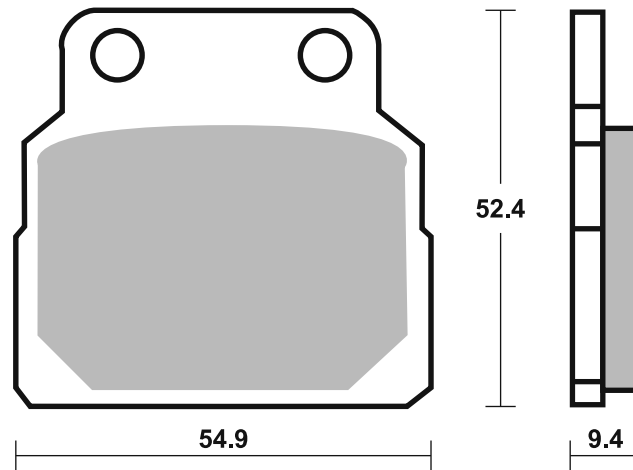



STREET HF • HS • LS  
 AMERICAN H.HF • H.CT • H.HS • H.LS  
 SCOOTER HF • CT • MS

RACING  
 OFF ROAD  
 ATV

RST • DC • DCC • DS-1 • DS-2 • RQ  
 SI • RSI • CS  
 ATS • SI • RSI • PSI

Drawings 1:1

Available compounds

RQ

SBS 599

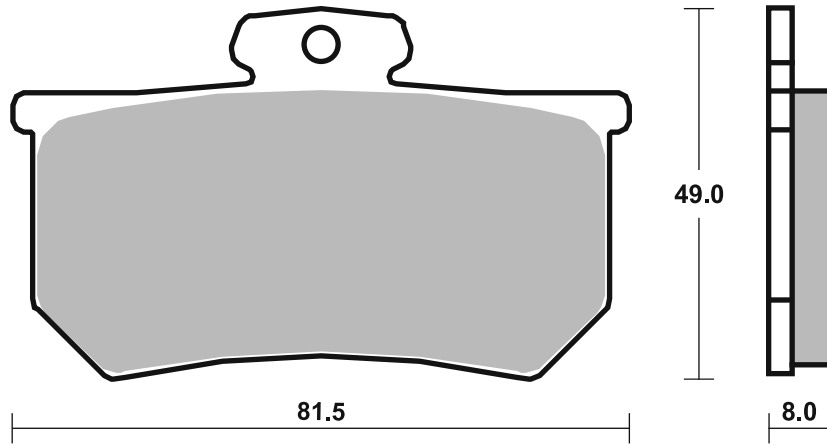

Available compounds

HF • HS

SBS 600

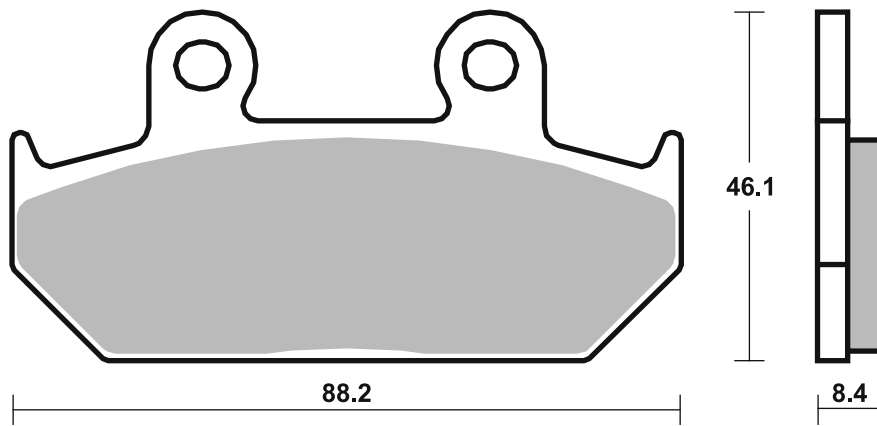

Available compounds

HF • RST

SBS 601

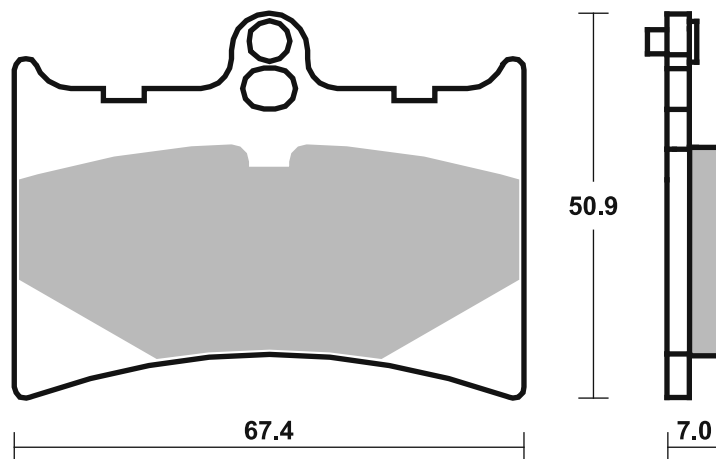

**SBS 602** Recommended compound



<b>KAWASAKI</b>			
KX	125	87 - 88	<b>HF</b>
KX	250	87 - 88	<b>HF</b>
KLR	500 (Austria)	87 - 88	<b>HF</b>
KX	500	87 - 88	<b>HF</b>
KLR	650	87 - 94	<b>HF</b>

**SBS 603** Recommended compound



<b>HONDA</b>			
CRM	75 R	90 - 94	<b>HF</b>
CR	125 RH, RJ, RK	87 - 94	<b>RSI</b>
AX-1	250	90 - 90	<b>HF</b>
CR	250 R	87 - 94	<b>RSI</b>
CRM	250 R	90 - 90	<b>HF</b>
NX	250	88 - 90	<b>SI</b>
TRX	250 R	86 - 89	<b>SI</b>
TRX	250 X Fourtrax	87 - 87	<b>SI</b>
XL	250 Degree	91 - 91	<b>SI</b>
XLR	250 R Baja	88 - 90	<b>SI</b>
XR	250 L	91 - 92	<b>SI</b>
XR	250 R	88 - 95	<b>SI</b>
ATC	350 X	86 - 89	<b>SI</b>
CR	500 R	87 - 94	<b>RSI</b>
XR	600 R	88 - 92	<b>SI</b>

Brake Pad 1:1 Drawings, Compounds, Fitments



STREET  
AMERICAN  
SCOOTER

HF • HS • LS  
H.HF • H.CT • H.HS • H.LS  
HF • CT • MS

RACING  
OFF ROAD  
ATV

RST • DC • DCC • DS-1 • DS-2 • RQ  
SI • RSI • CS  
ATS • SI • RSI • PSI

Drawings 1:1

Available compounds

HF

SBS 602

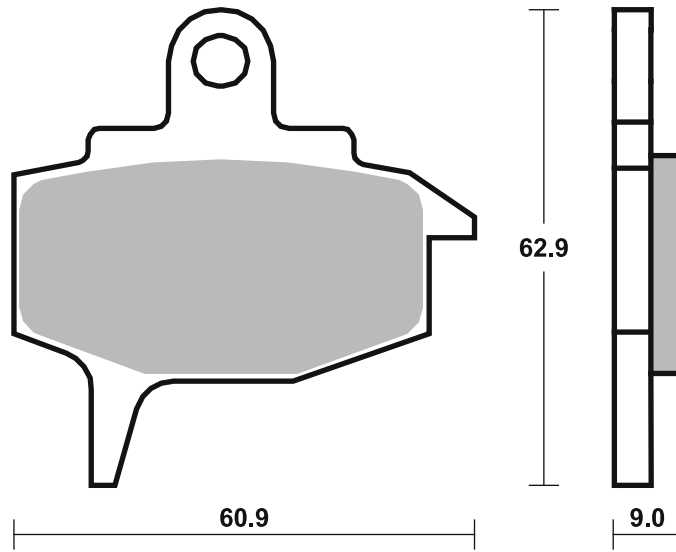
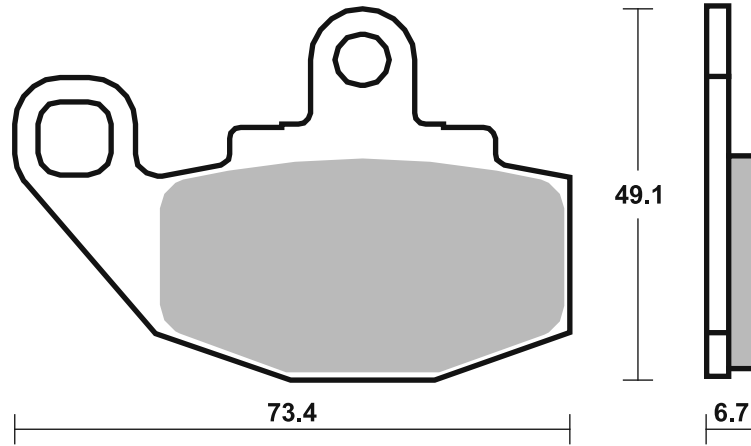

Available compounds

HF • SI • RSI

SBS 603

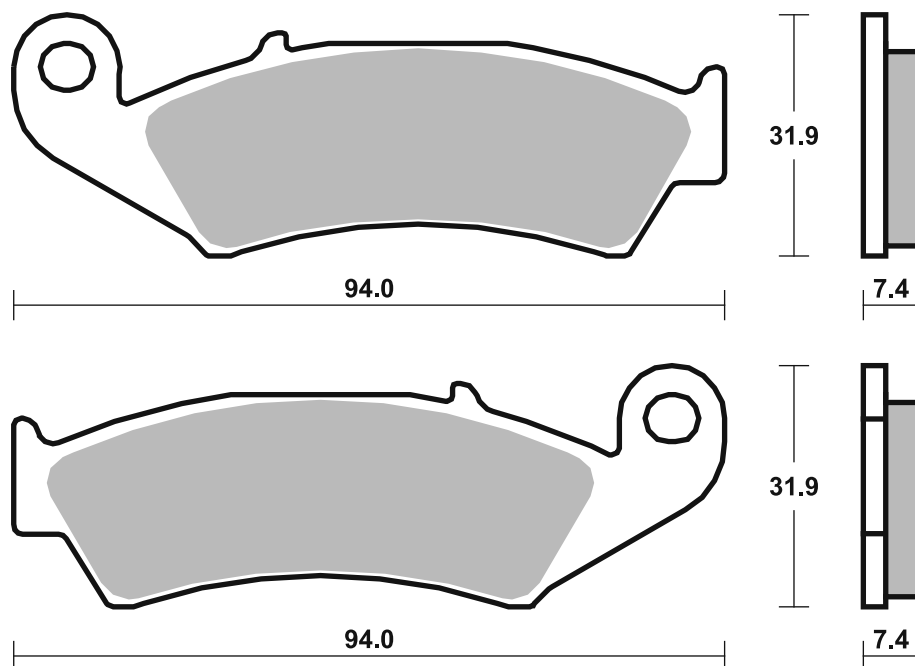

Dimensions in mm / Dimensions en mm  
1" = 25.4 mm, 1 mm = 0.04"

Brake Pad 1:1 Drawings,  
Compounds, Fitments



<b>AJP</b>			
PR5	250 Enduro	09 -09	<b>SI</b>
PR5	250 Supermotard	09 -09	<b>SI</b>
PR7	650 Adventure	17 -17	<b>HF</b>

<b>BIMOTA</b>			
BBX	508 Enduro	12 -12	<b>SI</b>

<b>BRACING</b>			
Rear cross (2 piston)			

<b>CPI</b>			
	125 Sahel	02 -02	<b>HF</b>

<b>FANTIC</b>			
	50 Regolarna		
	Competizione	08 -09	<b>HF</b>
MX	50 Regolarna		
	Competizione	08 -08	<b>RSI</b>
MX	65 Regolarna		
	Competizione	08 -08	<b>RSI</b>
	80 Regolarna		
	Competizione	08 -08	<b>HF</b>
MX	85 Regolarna		
	Competizione	08 -08	<b>RSI</b>
	125 Regolarna		
	Competizione	08 -08	<b>HF</b>

<b>GASGAS</b>			
EC	125	00 -06	<b>SI</b>
MC	125	03 -13	<b>RSI</b>
SM	125	02 -13	<b>HF</b>
EC	200	00 -09	<b>SI</b>
EC	200 Hobby	07 -16	<b>SI</b>
EC	250	00 -11	<b>SI</b>
EC	250 fse	02 -11	<b>SI</b>
MC	250	00 -13	<b>RSI</b>
SM	250	02 -13	<b>HF</b>
EC	300	00 -11	<b>SI</b>
	400 Pampera	06 -09	<b>SI</b>
EC	400 fse	02 -02	<b>SI</b>
SM	400 fse	02 -02	<b>HF</b>
EC	450 fse	03 -15	<b>SI</b>
EC	450 FSR	07 -16	<b>SI</b>
SM	450 fse	03 -06	<b>HF</b>
SM	450 FSR	07 -13	<b>HF</b>
EC	515 fsr	08 -16	<b>SI</b>

<b>HM</b>			
CRE	50	06 -13	<b>HF</b>
	125 Supermotard	00 -02	<b>HF</b>
CRE	125 Enduro	95 -01	<b>SI</b>
CRE	125 Supermotard	03 -03	<b>HF</b>
	250 Supermotard	00 -02	<b>HF</b>
CRE	250 Enduro	95 -01	<b>SI</b>
CRE	250 Supermotard	03 -03	<b>HF</b>

<b>HONDA</b>			
CRM	75 R	90 -94	<b>HF</b>
CR	80 R, RB	92 -02	<b>RSI</b>
CRM	80	89 -92	<b>HF</b>
CR	85 R, R Expert	03 -12	<b>RSI</b>
NSF	100	06 -06	<b>HF</b>
CR	125 R	95 -01	<b>RSI</b>
CR	125 RH, RJ, RK	87 -94	<b>RSI</b>
CRF	230 L	08 -10	<b>SI</b>
CRF	230 M	09 -12	<b>SI</b>
SL	230	97 -01	<b>HF</b>
CR	250 R	87 -01	<b>RSI</b>
XLR	250 R SPL	94 -94	<b>SI</b>
XR	250 L	91 -97	<b>HF</b>



<b>HONDA</b>			
XR	250 R	90 -95	<b>SI</b>
XR	250 S	96 -00	<b>HF</b>
XR	300	10 -12	<b>HF</b>
XR	400 R	96 -04	<b>SI</b>
XR	400 Supermotard	00 -03	<b>RSI</b>
XR	440 R	00 -03	<b>SI</b>
CR	500 R	87 -01	<b>RSI</b>
XR	600 R	91 -00	<b>SI</b>
XR	650 L	93 -18	<b>HF</b>
XR	650 R	00 -11	<b>SI</b>

<b>HYOSUNG</b>			
XRX	400	05 -08	<b>HF</b>

<b>KAWASAKI</b>			
KX	125	95 -08	<b>RSI</b>
KLX	250	98 -07	<b>SI</b>
KLX	250	14 -18	<b>HF</b>
KLX	250 S	09 -14	<b>HF</b>
KLX	250 SF	09 -10	<b>HF</b>
KX	250	95 -08	<b>RSI</b>
KLX	300	96 -07	<b>HF</b>
KLX	300	19 -23	<b>HF</b>
KLX	300 R	97 -07	<b>SI</b>
KLX	400 R	03 -04	<b>SI</b>
KLX	400 SR	03 -04	<b>HF</b>
KX	500	96 -04	<b>RSI</b>
KLX	650 R D1	96 -96	<b>SI</b>

<b>SHERCO</b>			
SE	450 4.5i Enduro	04 -04	<b>SI</b>

<b>SUZUKI</b>			
DR	125 SM	08 -12	<b>HF</b>
RM	125	96 -09	<b>RSI</b>
RM	250	96 -09	<b>RSI</b>
RMX	250 X-K1	99 -99	<b>SI</b>
DR-Z	400 S/E	00 -23	<b>HF</b>
DR-Z	400 SM	05 -24	<b>RSI</b>

<b>TM</b>			
MX	85	01 -12	<b>RSI</b>
EN	125 Enduro	01 -04	<b>SI</b>
MX	125	01 -04	<b>RSI</b>
SMR	125	05 -05	<b>RSI</b>
EN	250 Enduro	01 -04	<b>SI</b>
EN	250 F Enduro	01 -04	<b>SI</b>
MX	250	01 -04	<b>RSI</b>
MX	250 F	01 -04	<b>RSI</b>
EN	300 Enduro	01 -04	<b>SI</b>
MX	300	01 -04	<b>RSI</b>
	400 F	01 -01	<b>RSI</b>
	400 F Enduro	01 -01	<b>SI</b>
SMF	400 F	02 -02	<b>RSI</b>
SMR	400 F	03 -03	<b>RSI</b>
EN	450 F Enduro	02 -04	<b>SI</b>
MX	450 F	02 -04	<b>RSI</b>
SMR	450 F	04 -04	<b>RSI</b>
SMX	450 F	03 -04	<b>RSI</b>
EN	530 F Enduro	01 -04	<b>SI</b>
MX	530 F	01 -04	<b>RSI</b>
SMR	530 F	03 -03	<b>RSI</b>
SMX	600 F	03 -03	<b>RSI</b>
SMX	660 F	04 -04	<b>RSI</b>

<b>YAMAHA</b>			
WR	125	98 -02	<b>SI</b>
YZ	125	98 -02	<b>RSI</b>
WR	250	98 -02	<b>SI</b>
WR	250 F	01 -02	<b>SI</b>



<b>YAMAHA</b>			
YZ	250	98 -02	<b>RSI</b>
YZ	250 F	01 -02	<b>RSI</b>
WR	400 F	99 -00	<b>SI</b>
YZ	400 F	99 -99	<b>RSI</b>
WR	426 F	01 -02	<b>SI</b>
YZ	426 F	00 -02	<b>RSI</b>

STREET  
AMERICAN  
SCOOTER

HF • HS • LS  
H.HF • H.CT • H.HS • H.LS  
HF • CT • MS

RACING  
OFF ROAD  
ATV

RST • DC • DCC • DS-1 • DS-2 • RQ  
SI • RSI • CS  
ATS • SI • RSI • PSI

Drawings 1:1

Available compounds

HF • RQ • CS • SI • RSI

SBS 604

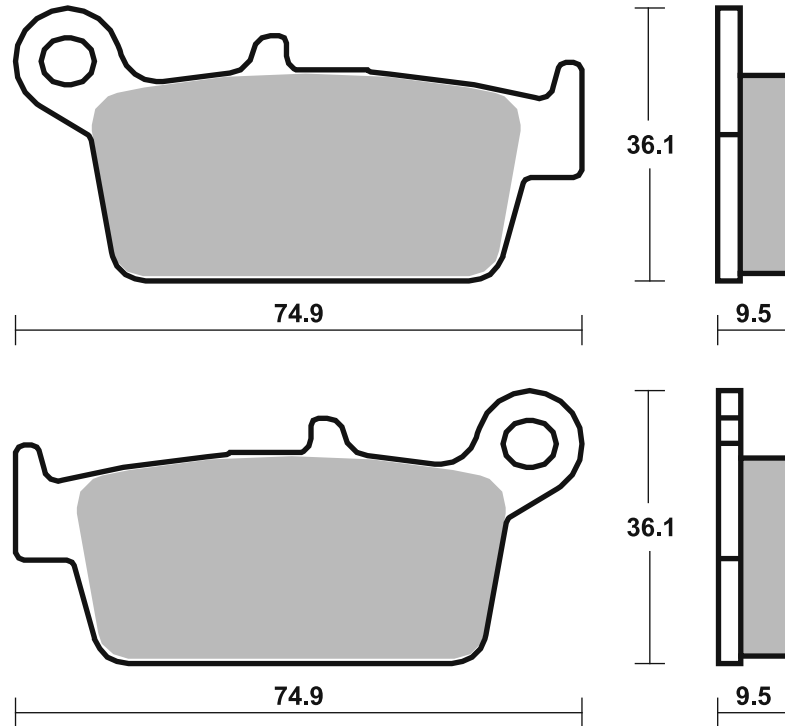

## Applications

### SBS 605

### Recommended compound



<b>APRILIA</b>			
	125 Tuareg	87 - 92	<b>HF</b>
	125 Tuareg AS	86 - 86	<b>HF</b>
STX	125	84 - 84	<b>HF</b>
ETX	350	87 - 92	<b>HF</b>
<b>BETA</b>			
RX	50	84 - 84	<b>HF</b>
RX	125	84 - 84	<b>HF</b>
<b>GILERA</b>			
RV	200	85 - 86	<b>HF</b>

### SBS 606

### Recommended compound



<b>APRILIA</b>			
ETX	125 PV	86 - 02	<b>HF</b>
RX	125	86 - 89	<b>HF</b>
TX	125	86 - 86	<b>HF</b>
<b>MOTO-MORINI</b>			
	125 KJ	84 - 88	<b>HF</b>
	350 Excalibur	87 - 89	<b>HF</b>
	350 K2	84 - 87	<b>HF</b>
RLX	501 Excalibur	87 - 87	<b>HF</b>

### SBS 607

### Recommended compound



<b>APRILIA</b>			
	50 Red Rose		
	Classic	92 - 94	<b>HF</b>
	50 Tuareg	86 - 96	<b>HF</b>
	50 Tuareg Rally	90 - 96	<b>HF</b>
	125 Tuareg Wind	88 - 88	<b>HF</b>
	240 Climber	89 - 90	<b>HF</b>
	275 Climber	89 - 90	<b>HF</b>
<b>BETA</b>			
ALP	50	91 - 00	<b>HF</b>
MX	50 Enduro	92 - 92	<b>HF</b>
ALP	125	90 - 90	<b>HF</b>
TR	125 34	88 - 88	<b>HF</b>
TR	260 34	86 - 88	<b>HF</b>
<b>DERBI</b>			
	75 GPR	89 - 89	<b>HF</b>
GPR	75 Sport	92 - 92	<b>HF</b>



<b>FANTIC</b>			
	50 Fast	88 - 88	<b>HF</b>
	50 Oasis	90 - 90	<b>HF</b>
	75 Oasis	89 - 89	<b>HF</b>
<b>GARELLI</b>			
	50 Sahel	91 - 91	<b>HF</b>
<b>MALAGUTI</b>			
MDX	50 Gold Enduro	87 - 87	<b>HF</b>
MLX	50 Enduro	87 - 87	<b>HF</b>
<b>PEUGEOT</b>			
XPLD	50 AV	90 - 90	<b>HF</b>

STREET  
AMERICAN  
SCOOTER

HF • HS • LS  
H.HF • H.CT • H.HS • H.LS  
HF • CT • MS

RACING  
OFF ROAD  
ATV

RST • DC • DCC • DS-1 • DS-2 • RQ  
SI • RSI • CS  
ATS • SI • RSI • PSI

Available compounds

HF

SBS 605

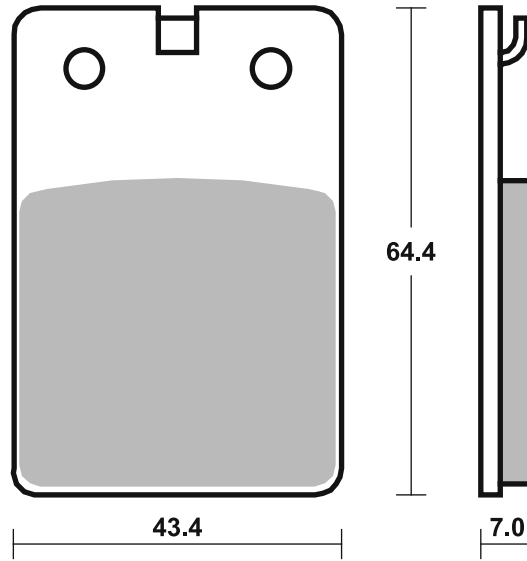

Available compounds

HF

SBS 606

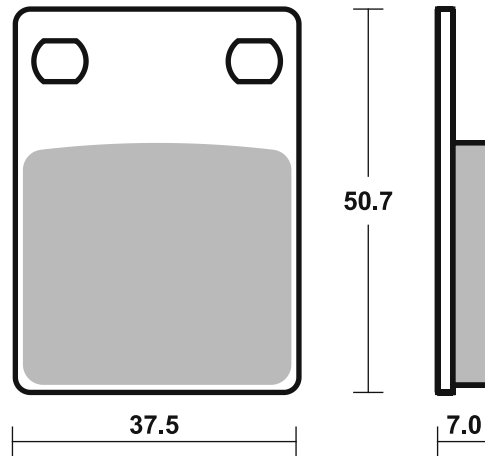

Available compounds

HF

SBS 607

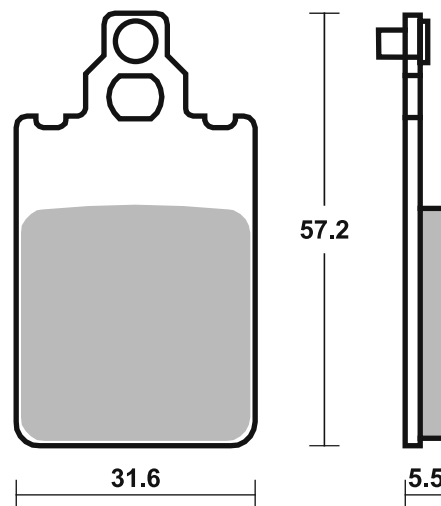

## Applications

### SBS 608

### Recommended compound



<b>APRILIA</b>			
AF1	125	87 - 87	<b>HF</b>
AF1	125	88 - 88	<b>HF</b>

<b>CAGIVA</b>			
WMX	50	89 - 89	<b>HF</b>
	125 Cross	86 - 86	<b>SI</b>
	125 Cruiser	89 - 89	<b>HF</b>
	125 Freccia	89 - 89	<b>HF</b>
	125 Supercity	92 - 00	<b>HF</b>
	125 Tamanaco	87 - 92	<b>HF</b>
WMX	125	88 - 88	<b>SI</b>
	250 Cross	86 - 86	<b>SI</b>
WMX	250	89 - 90	<b>SI</b>

<b>GILERA</b>			
	125 Apache	91 - 94	<b>HF</b>
RC	125 Top Rally	90 - 93	<b>HF</b>
RC	600 Top Rally	90 - 94	<b>HF</b>

<b>HM</b>			
CRE	50	98 - 01	<b>HF</b>

<b>HUSABERG</b>			
	all models	89 - 92	<b>SI</b>
	350	91 - 92	<b>SI</b>
	500	91 - 98	<b>SI</b>
	501 Enduro	91 - 94	<b>SI</b>
	600 Enduro	91 - 94	<b>SI</b>

<b>HUSQVARNA</b>			
	all models TE,TC, WR,CR,AE	89 - 89	<b>SI</b>
CR/WR	125	91 - 91	<b>SI</b>
WR	125	85 - 90	<b>SI</b>
WRK	125	90 - 90	<b>SI</b>
WR	240	87 - 91	<b>SI</b>
WRK	240	90 - 90	<b>SI</b>
CR	250	91 - 91	<b>SI</b>
WR/XC	250	87 - 90	<b>SI</b>
WR	260	90 - 93	<b>SI</b>
TE	350 Enduro	90 - 90	<b>SI</b>
WR	400	87 - 88	<b>SI</b>
	430 Auto	87 - 87	<b>SI</b>
CR	430	87 - 89	<b>SI</b>



<b>HUSQVARNA</b>			
WR	430	87 - 89	<b>SI</b>
XC	430	87 - 88	<b>SI</b>
XC	500	87 - 88	<b>SI</b>
	510	87 - 90	<b>SI</b>
TC	610 Cross	91 - 91	<b>SI</b>
TE	610	91 - 95	<b>SI</b>

<b>KRAM-IT</b>			
ER	125	89 - 93	<b>SI</b>
MC	250	89 - 89	<b>SI</b>
ER	300	89 - 89	<b>SI</b>

<b>MOTO-MORINI</b>			
	350 Coguaro	90 - 95	<b>HF</b>
	350 Coguaro, New York	90 - 94	<b>HF</b>
	350 Dart	88 - 88	<b>HF</b>
RLX	350 Excalibur	90 - 92	<b>HF</b>
	400 Dart	89 - 89	<b>HF</b>
	501 Coguaro	89 - 89	<b>HF</b>
RLX	501 Excalibur	90 - 90	<b>HF</b>

<b>YAMAHA</b>			
DT	125 Tenere	89 - 90	<b>HF</b>
TDR	125 (Italy)	90 - 93	<b>SI</b>

<b>ZANELLA</b>			
TZ4	125 Patagonia (ARG)	92 - 92	<b>HF</b>

### SBS 610

### Recommended compound



<b>HONDA</b>			
FL	350 R Odyssey	85 - 87	<b>HF</b>
FL	400 R Pilot	89 - 90	<b>HF</b>

STREET  
AMERICAN  
SCOOTER

HF • HS • LS  
H.HF • H.CT • H.HS • H.LS  
HF • CT • MS

RACING  
OFF ROAD  
ATV

RST • DC • DCC • DS-1 • DS-2 • RQ  
SI • RSI • CS  
ATS • SI • RSI • PSI

Drawings 1:1

Available compounds

HF • SI • RSI

SBS 608

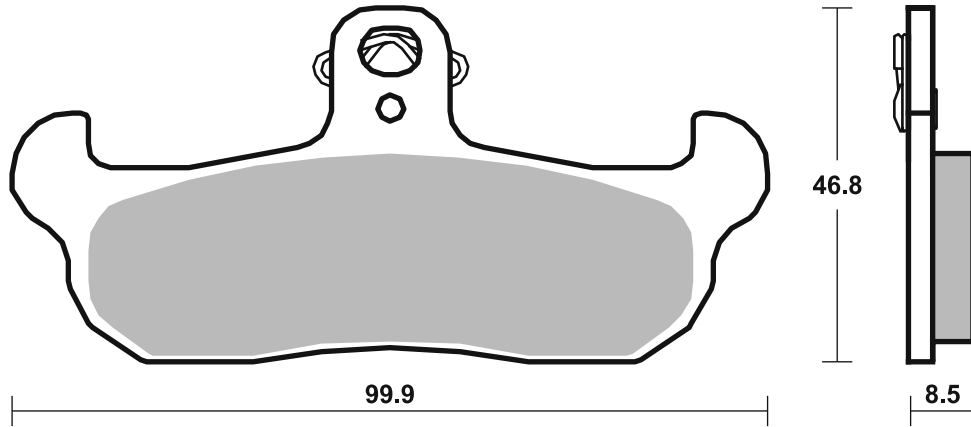

Available compounds

HF

SBS 610

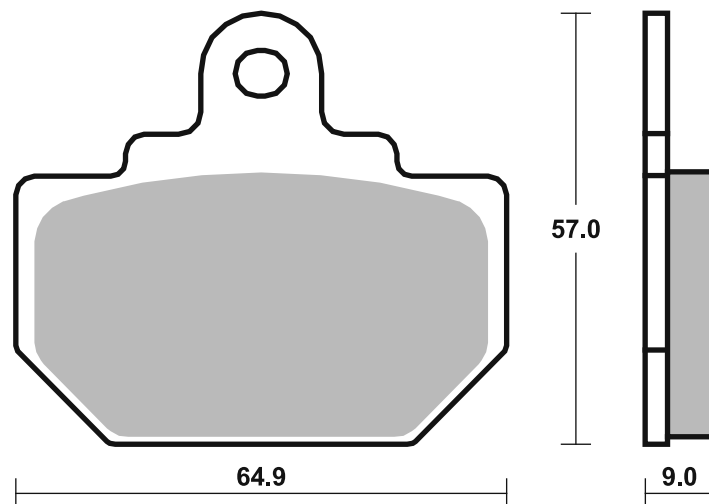



<b>APRILIA</b>			
SX	125	18 - 22	HF
<b>CAGIVA</b>			
	110 Passing	94 - 94	HF
	600 Canyon	95 - 99	HS
<b>CAN-AM</b>			
	600 Ryker	19 - 23	PSI
	800 Commander	11 - 14	SI
	900 Ryker	19 - 23	PSI
	900 Ryker Rally	19 - 23	PSI
	900 Ryker S	19 - 23	PSI
<b>CF MOTO</b>			
	550 U-Force	15 - 16	SI
	550 Z-Force	15 - 16	SI
	800 Z-Force EX	15 - 15	SI
<b>DERBI</b>			
DXR	200 Quad		
	(Front drum)	04 - 05	SI
DXR	250 Quad		
	(Front drum)	04 - 05	SI
<b>HONDA</b>			
NSR	150	02 - 02	HF
<b>HOREX</b>			
VR6	1200	11 - 16	LS
<b>HUSQVARNA</b>			
	all models CR, TC,TE,WR	92 - 94	SI
<b>HYOSUNG</b>			
	125 Aquila	00 - 04	HF
<b>KAWASAKI</b>			
KLX	125	10 - 14	HF
KLX	125 D-Tracker	10 - 14	HF
KX	125	89 - 93	RSI
KLX	140 , L	08 - 24	SI
KLX	150 D-Tracker	16 - 18	HF
KLX	150 L	14 - 15	HF
KDX	200	93 - 93	SI
KLX	230	19 - 22	HF
KLX	230 R	22 - 23	HF
KLX	230 SE	22 - 22	HF
KDX	250 SR	91 - 94	SI
KLX	250	14 - 18	HF
KLX	250 S	09 - 14	HF
KLX	250 SF	09 - 10	HF
KX	250	89 - 93	RSI
EL	252	01 - 03	HS
KLF	300 Bayou 4x4	89 - 05	SI
KLX	300	19 - 23	HF
KLF	400 Bayou	93 - 99	SI
KX	500	89 - 93	RSI
KLR	650	08 - 18	HS
KVF	650 Brute Force 4x4i	05 - 11	SI
KRF	750 Teryx 4x4	08 - 13	SI
KVF	750 Brute Force 4x4i	05 - 15	SI
	800 Mule Pro FX	15 - 17	SI
KRF	800 Teryx		
	BEF/CEF/DEF	14 - 17	SI
KRT	800 Teryx 4		
	BEF/CEF/DEF	14 - 17	SI
ZX	1000 H2 SX	18 - 24	LS
ZX	1000 H2 SX SE	18 - 24	LS
ZX	1000 H2 SX SE+	19 - 21	LS



<b>SUZUKI</b>			
EN	125	05 - 09	HF
RM	125	87 - 87	SI
RM	125	88 - 90	RSI
TS	125	89 - 96	HF
TS	200 R	90 - 94	HF
DR	250	90 - 95	HF
RM	250	87 - 90	RSI
RMX	250	89 - 95	RSI
LT-F	300 King Quad	02 - 02	SI
DR	350	90 - 99	HF
LT-R	450	06 - 12	SI
LT-A	500 FY Quadmaster	00 - 08	SI
LT-F	500 F	98 - 07	SI
RM	500	88 - 89	RSI
<b>TRIUMPH</b>			
	750 Trident	91 - 98	HS
	800 America	03 - 06	LS
	800 Bonneville	01 - 04	LS
	800 Bonneville		
	America	02 - 06	LS
	800 Bonneville		
	Speedmaster	03 - 04	LS
	800 Bonneville T100		
	Centennial		
	Edition	02 - 04	LS
	800 Bonneville T100		
	Paul Smith	06 - 08	LS
	900 America	07 - 16	LS
	900 Bonneville	09 - 11	LS
	900 Bonneville		
	Newchurch	15 - 15	LS
	900 Bonneville SE	09 - 13	LS
	900 Bonneville		
	Speedmaster	05 - 15	LS
	900 Bonneville Spirit	15 - 15	LS
	900 Bonneville Street		
	Cup	17 - 18	LS
	900 Bonneville T100	05 - 23	LS
	900 Bonneville T100		
	Black	16 - 20	LS
	900 Bonneville T214	15 - 15	LS
	900 Daytona, Sprint	93 - 93	HS
	900 Scrambler	06 - 16	LS
	900 Scrambler	23 - 23	LS
	900 Speed Twin	23 - 23	LS
	900 Street Cup	17 - 20	LS
	900 Street Scrambler	17 - 22	LS
	900 Street Twin	16 - 22	LS
	900 T100 Bud Ekins	20 - 20	LS
	900 Thruxton	04 - 05	LS
	900 Thruxton Ace	15 - 15	LS
	900 Tiger	93 - 98	HS
	900 Trident	91 - 98	HS
	900 Trophy	91 - 95	HS
T509	900 Speed Triple	97 - 01	LS
T595	950 Daytona	96 - 98	LS
	955 Daytona		
	Centennial	02 - 04	LS
	955 Daytona		
	to VIN 132512	99 - 06	LS
	955 Speed Triple	99 - 06	LS
	955 Sprint RS	00 - 05	LS
	955 Sprint ST	99 - 04	LS
	1000 Trophy	91 - 95	HS
	1050 Speed 94	15 - 16	LS
	1050 Speed 94R	15 - 16	LS
	1050 Speed Triple	05 - 15	LS
	1050 Speed Triple R	12 - 18	LS
	1050 Speed Triple RS	16 - 20	LS



<b>TRIUMPH</b>			
	1050 Speed Triple S	16 - 20	LS
	1050 Sprint GT ABS	10 - 15	LS
	1050 Sprint GT SE		
	ABS	10 - 15	LS
	1050 Sprint ST	05 - 11	LS
	1050 Tiger Sport	15 - 19	LS
	1200 Bonneville T120	16 - 23	LS
	1200 Bonneville T120		
	Ace	19 - 20	LS
	1200 Bonneville T120		
	Black	16 - 23	LS
	1200 Bonneville T120		
	Diamond Ed.	19 - 20	LS
	1200 Speed Twin	19 - 23	LS
	1200 T120 Bud Ekins	20 - 20	LS
	1200 Thruxton	16 - 19	LS
	1200 Thruxton R	16 - 19	LS
	1200 Thruxton RS	20 - 23	LS
	1200 Tiger Explorer	12 - 17	LS
	1200 Tiger XCA	18 - 20	LS
	1200 Tiger XCX	18 - 20	LS
	1200 Tiger XR	18 - 19	LS
	1200 Tiger XRT	18 - 20	LS
	1200 Tiger XRX	18 - 20	LS
	1200 Tiger XRX Low	18 - 20	LS
	1200 Trophy	91 - 95	HS
	1200 Trophy SE	13 - 18	LS
<b>YAMAHA</b>			
FZR	50	92 - 92	HF
YD	80	89 - 89	HF
WR	125	91 - 97	SI
XTZ	125	05 - 20	HF
YZ	125	89 - 95	RSI
DT	200 WR	91 - 93	HF
WR	200	91 - 92	SI
TT-R	230	05 - 22	SI
TT	250	93 - 03	SI
WR	250	90 - 97	SI
YZ	250	89 - 89	RSI
YZ	250 A	90 - 90	RSI
YZ	250 B1-J1	91 - 97	RSI
YZ	250 WRA,WRB	90 - 91	RSI
TT	350	95 - 00	SI
YZ	360	89 - 89	SI
YFZ	450 S	04 - 09	SI
YXR	450 Rhino	06 - 09	SI
WR	500 B	91 - 91	SI
WR	500 ZD,ZE	92 - 93	SI
	660 Rhino	05 - 08	SI
YFM	700 R Raptor	06 - 08	SI
YFM	700 Raptor	09 - 14	SI
YXR	700 Rhino	08 - 14	SI
XTZ	750 Super Tenere	89 - 95	HF



STREET  
AMERICAN  
SCOOTER

HF • HS • LS  
H.HF • H.CT • H.HS • H.LS  
HF • CT • MS

RACING  
OFF ROAD  
ATV

RST • DC • DCC • DS-1 • DS-2 • RQ  
SI • RSI • CS  
ATS • SI • RSI • PSI

Drawings 1:1

Available compounds

HF • HS • LS • RQ • SI • RSI • PSI

SBS 611

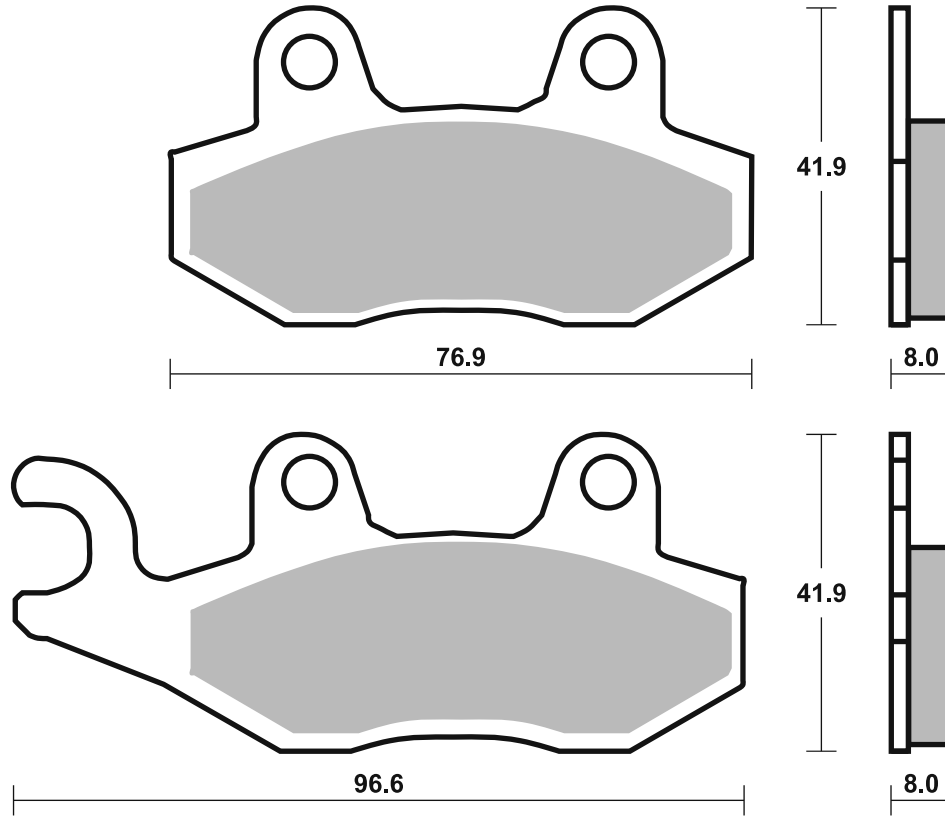

## Applications

### SBS 613

### Recommended compound



<b>YAMAHA</b>			
FZR	400 A	90 - 90	<b>HS</b>
SRX	400	85 - 86	<b>HF</b>
SRX	600	90 - 99	<b>HS</b>
FZR	750 R Genesis	87 - 88	<b>HF</b>
TRX	850	95 - 00	<b>HS</b>
FZR	1000 Genesis	87 - 89	<b>HF</b>
FJ	1200	88 - 90	<b>HF</b>
FJ	1200 ABS	91 - 93	<b>HS</b>
XJR	1200	94 - 98	<b>HS</b>
XJR	1200 SP	97 - 98	<b>HS</b>
XVZ	1300 A Royal Star	96 - 07	<b>HS</b>
XVZ	1300 AT Royal Star		
	Tour Classic	97 - 07	<b>HS</b>
XVZ	1300 Royal Star		
	Boulevard	99 - 01	<b>HS</b>
XVZ	1300 Venture Royale	86 - 89	<b>HF</b>
XVZ	1300 Venture Royale	90 - 95	<b>HS</b>

### SBS 614

### Recommended compound



<b>BUELL</b>			
	500 Blast	01 - 09	<b>HF</b>
XB9R	984 Firebolt	02 - 10	<b>LS</b>
XB9S	984 Lightning	03 - 10	<b>LS</b>
XB9SX	984 CityX	05 - 10	<b>LS</b>
M2	1200 Cyclone	98 - 02	<b>LS</b>
S1	1200 Lightning	98 - 02	<b>LS</b>
S1	1200 Whitelightning	98 - 02	<b>LS</b>
S3	1200 Thunderbolt	98 - 02	<b>LS</b>
X1	1200 Lightning	01 - 02	<b>LS</b>
XB12R	1200 Firebolt	04 - 10	<b>LS</b>
XB12S	1200 Lightning	04 - 08	<b>LS</b>
XB12Scg	1200 Lightning	06 - 10	<b>LS</b>
XB12Ss	1200 Lightning Long	06 - 10	<b>LS</b>
XB12STT	1200 Super TT	07 - 10	<b>LS</b>
XB12X	1200 Ulysses	06 - 10	<b>LS</b>

#### HONDA

CBR	250 Hurricane	87 - 87	<b>HF</b>
CBR	250 R, RR	90 - 90	<b>HF</b>
CBR	250 RJ	88 - 88	<b>HF</b>
NSR	250 R, SP	90 - 90	<b>LS</b>
NSR	250 RJ	88 - 89	<b>HF</b>
RS	250 R	91 - 92	<b>HF</b>
VT	250 Spada	89 - 89	<b>HF</b>
VTR	250	98 - 02	<b>HF</b>
CB	400 Super Four	92 - 95	<b>LS</b>
CB-1	400 (CB 400 F)	89 - 90	<b>LS</b>
CBR	400 RR	87 - 89	<b>LS</b>
NTV	400 Bros II	88 - 88	<b>HF</b>
VFR	400 R	87 - 88	<b>LS</b>
VRX	400 T Roadstar	95 - 99	<b>LS</b>
NX	500 Dominator		
	(Austria)	88 - 96	<b>LS</b>
NTV	600 Bros I	88 - 93	<b>HF</b>
NTV	600 Revere	88 - 92	<b>HF</b>
XL	600 V, Transalpino	91 - 99	<b>LS</b>
FMX	650 Rally	05 - 08	<b>LS</b>
NT	650 Hawk GT	88 - 91	<b>LS</b>
NT	650 V Deauville	98 - 00	<b>LS</b>
NTV	650	94 - 97	<b>LS</b>
NTV	650 Bros	88 - 97	<b>LS</b>
NTV	650 Revere	88 - 93	<b>LS</b>
NX	650 Dominator	93 - 96	<b>LS</b>
NX	650 Dominator J-K	88 - 92	<b>LS</b>



<b>HONDA</b>			
XL	650 V Transalp	00 - 07	<b>LS</b>
XRV	650 Africa Twin	88 - 89	<b>LS</b>
NC	700 S	12 - 13	<b>LS</b>
NC	700 X	12 - 13	<b>LS</b>
VFR	700 F Interceptor	88 - 89	<b>LS</b>
XL	700 Transalp	08 - 11	<b>LS</b>
XRV	750 Africa Twin	90 - 03	<b>LS</b>

#### MOTO-GUZZI

	1000 Quota	92 - 92	<b>HF</b>
--	------------	---------	-----------

#### SUZUKI

XF	650 Freewind	97 - 02	<b>LS</b>
----	--------------	---------	-----------

#### TRIUMPH

	600 Daytona	03 - 04	<b>LS</b>
	600 Speed Four	03 - 06	<b>LS</b>
TT	600	00 - 03	<b>LS</b>
	650 Daytona	05 - 06	<b>LS</b>
	660 Tiger Sport	22 - 23	<b>LS</b>
	660 Trident	21 - 23	<b>LS</b>
	675 Daytona	06 - 08	<b>LS</b>
	675 Daytona R Triple	11 - 12	<b>LS</b>
	675 Daytona Triple	09 - 12	<b>LS</b>
	675 Street Triple	08 - 12	<b>LS</b>
	675 Street Triple R	09 - 12	<b>LS</b>
	800 Tiger	11 - 14	<b>LS</b>
	800 Tiger XC	11 - 17	<b>LS</b>
	800 Tiger XC ABS	12 - 14	<b>LS</b>
	800 Tiger XCA	15 - 18	<b>LS</b>
	800 Tiger XCR	15 - 17	<b>LS</b>
	800 Tiger XCX	18 - 20	<b>LS</b>
	800 Tiger XR	15 - 18	<b>LS</b>
	800 Tiger XRT	15 - 18	<b>LS</b>
	800 Tiger XRX	15 - 18	<b>LS</b>
	800 Tiger XRX Low	18 - 20	<b>LS</b>
	955 Daytona		
	from VIN 132513	99 - 01	<b>LS</b>
	1200 Bonneville		
	Bobber	17 - 23	<b>LS</b>
	1200 Bonneville		
	Bobber Black	18 - 23	<b>LS</b>
	1200 Bonneville		
	Speedmaster	18 - 23	<b>LS</b>



<b>YAMAHA</b>			
FZ6R	600	09 - 14	<b>LS</b>
XJ6	600 Diversion	09 - 15	<b>LS</b>
XJ6-F	600	09 - 12	<b>LS</b>
XJ6-N	600	09 - 12	<b>LS</b>
XJ6-S	600	09 - 12	<b>LS</b>

STREET  
AMERICAN  
SCOOTER

HF • HS • LS  
H.HF • H.CT • H.HS • H.LS  
HF • CT • MS

RACING  
OFF ROAD  
ATV

RST • DC • DCC • DS-1 • DS-2 • RQ  
SI • RSI • CS  
ATS • SI • RSI • PSI

Drawings 1:1

Available compounds

HF • HS • DCC

SBS 613

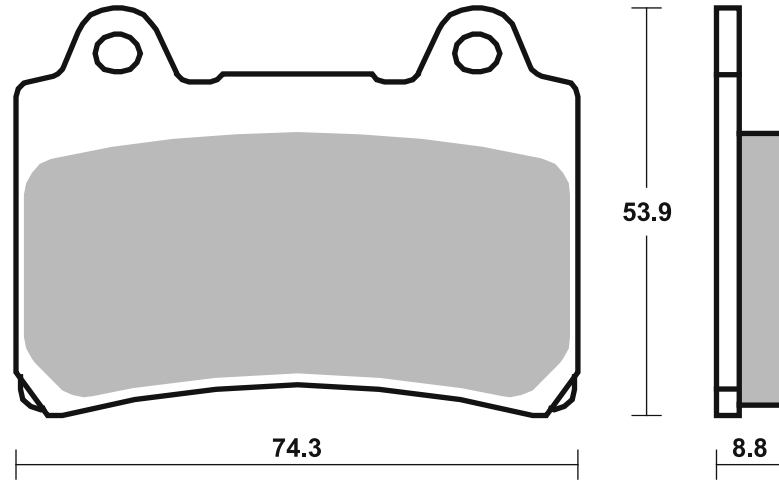

Available compounds

HF • LS • RQ

SBS 614

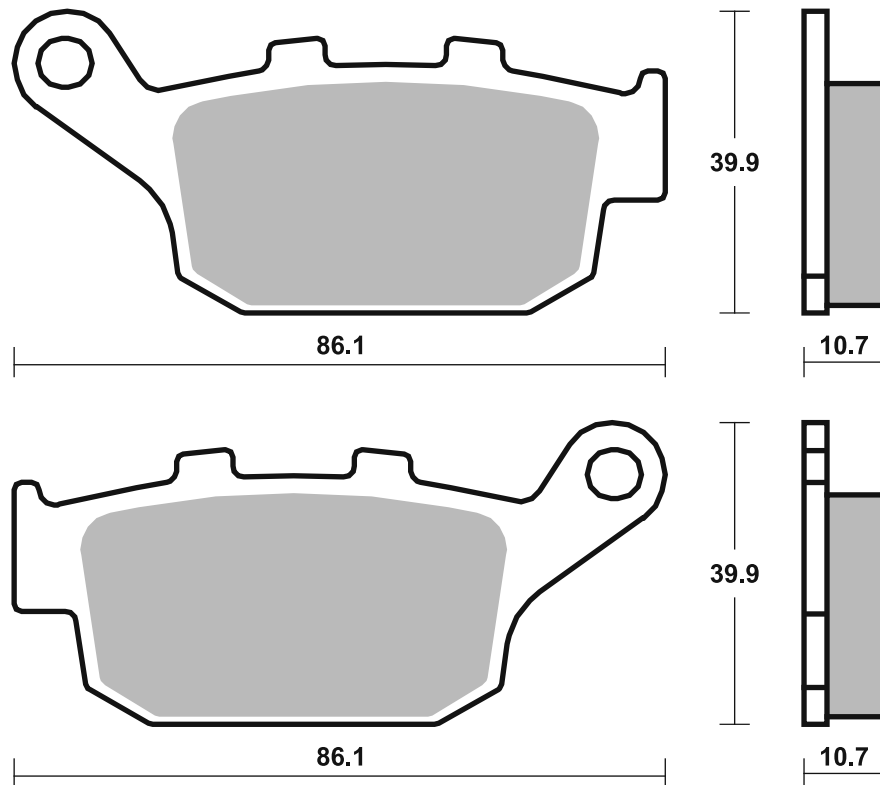

Applications

**SBS 615**

**Recommended compound**



**KAWASAKI**

EX	250 R Ninja	88 - 07	<b>HF</b>
GPX	250 R	88 - 91	<b>HF</b>
KR-1	250 S	89 - 89	<b>HF HF</b>
ZXR	250	90 - 90	<b>HS LS</b>
ZXR	250 R	89 - 89	<b>HS LS</b>
GPX	400	87 - 87	<b>HF</b>
GPZ	400 R	89 - 89	<b>HS</b>
ZR	400 Xanthus		
	(ZR 400D1)	92 - 95	<b>HS</b>
ZX-4	400	88 - 89	<b>HF HF</b>
EX	500	94 - 96	<b>HS</b>
GPZ	500	97 - 04	<b>HS</b>
GPZ	500 S (Austria)	94 - 01	<b>HS</b>
ZR	550 Zephyr	90 - 92	<b>LS</b>
ZR	550 Zephyr (D) from		
	VIN B024010-	93 - 01	<b>HS</b>

**SUZUKI**

RGV	250	93 - 95	<b>HF</b>
RGV	250 Gamma	91 - 92	<b>HF</b>
GSX	1100 G	94 - 95	<b>LS</b>

**SBS 616**

**Recommended compound**



**YAMAHA**

XV	250 Virago	89 - 94	<b>HF</b>
XV	400 Virago, SPL	88 - 88	<b>HF</b>
XV	535 Virago	87 - 94	<b>HF</b>

STREET  
AMERICAN  
SCOOTER

HF • HS • LS  
H.HF • H.CT • H.HS • H.LS  
HF • CT • MS

RACING  
OFF ROAD  
ATV

RST • DC • DCC • DS-1 • DS-2 • RQ  
SI • RSI • CS  
ATS • SI • RSI • PSI

Drawings 1:1

Available compounds

HF • HS • LS • RQ

SBS 615

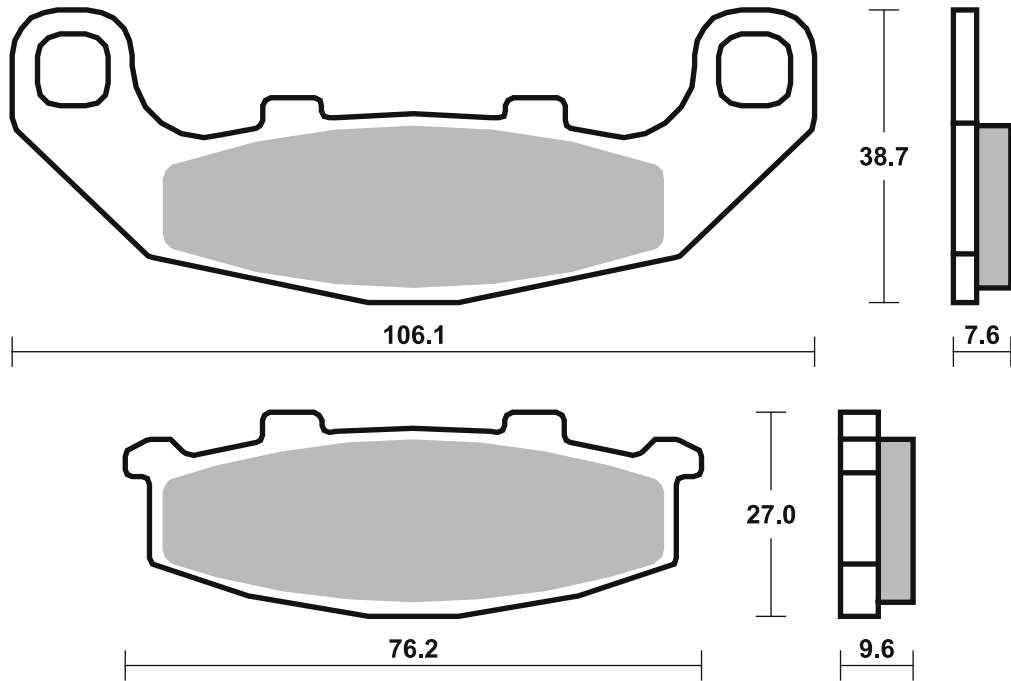

Available compounds

HF

SBS 616

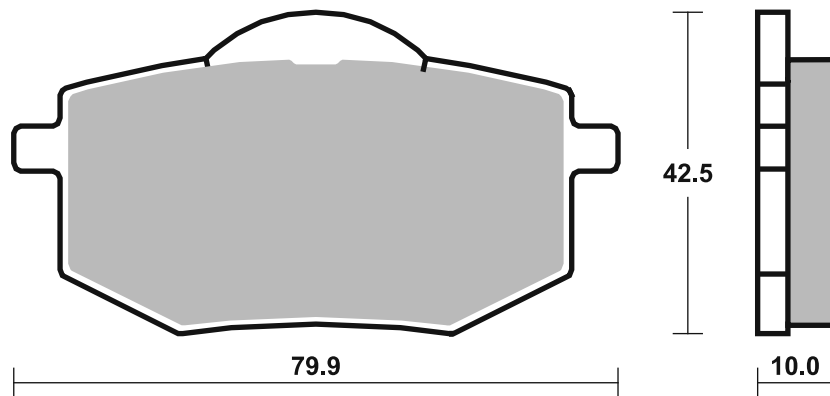

## Applications

### SBS 617 Recommended compound



#### YAMAHA

YT	125 Tri Moto	80 - 81	<b>HF</b>

### SBS 618 Recommended compound



#### HONDA

R	50 Monkey	88 - 88	<b>HF</b>
R	80 Lead	88 - 95	<b>HF</b>
NS	125	89 - 89	<b>HF</b>
R	125 Lead	88 - 88	<b>HF</b>
RS	125	95 - 03	<b>RQ</b>
RS	125 R	91 - 94	<b>HF</b>
NS	250	89 - 89	<b>HF</b>
NSF	250 R	11 - 21	<b>RQ</b>
RS	250 R	93 - 93	<b>RQ</b>

### SBS 619 Recommended compound



#### BENELLI

KB-X	50 Race	14 - 14	<b>HF</b>

#### YAMAHA

JOG-Z	50	88 - 89	<b>HF</b>
TZR	80	92 - 95	<b>HF</b>

Brake Pad 1:1 Drawings, Compounds, Fittings

STREET  
AMERICAN  
SCOOTER

HF • HS • LS  
H.HF • H.CT • H.HS • H.LS  
HF • CT • MS

RACING  
OFF ROAD  
ATV

RST • DC • DCC • DS-1 • DS-2 • RQ  
SI • RSI • CS  
ATS • SI • RSI • PSI

Drawings 1:1

Available compounds

HF

SBS 617

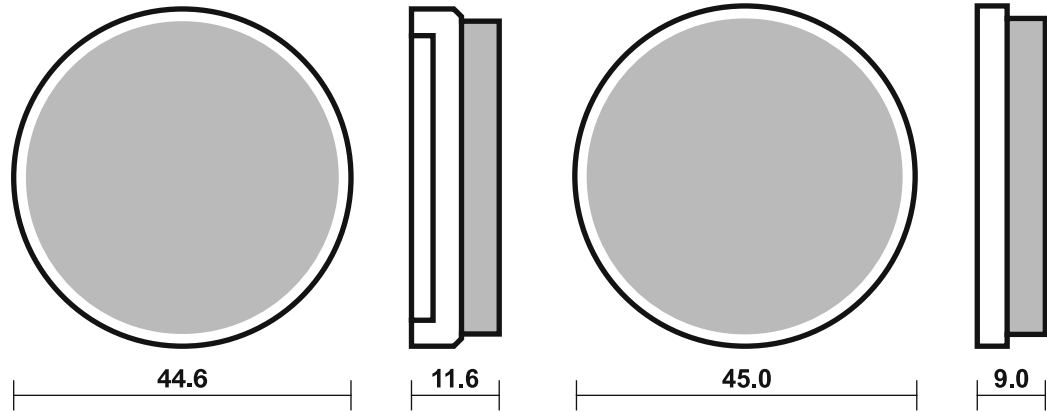

Available compounds

HF • RQ

SBS 618

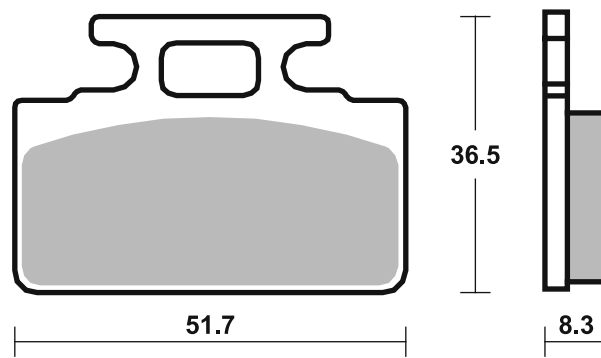

Available compounds

HF

SBS 619

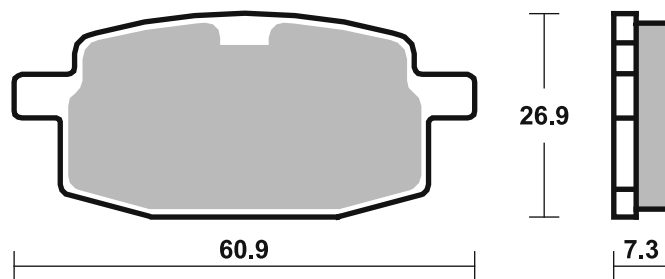





STREET  
AMERICAN  
SCOOTER

HF • HS • LS  
H.HF • H.CT • H.HS • H.LS  
HF • CT • MS

RACING  
OFF ROAD  
ATV

RST • DC • DCC • DS-1 • DS-2 • RQ  
SI • RSI • CS  
ATS • SI • RSI • PSI

Drawings 1:1

Available compounds

HF • HS • LS

SBS 620

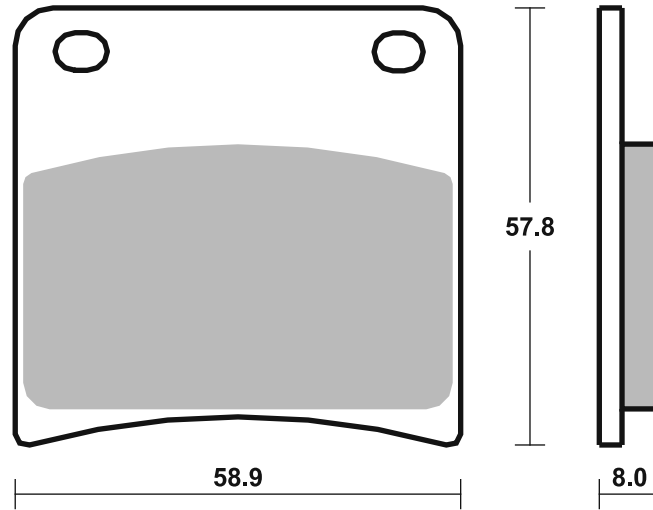

Available compounds

HF

SBS 621

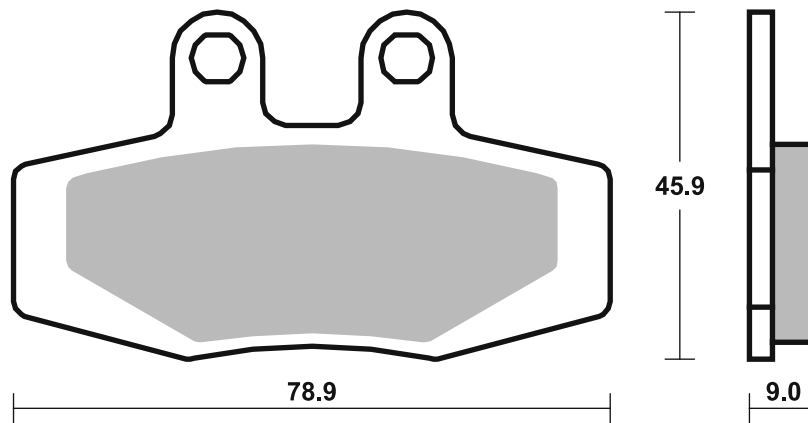

Available compounds

HF • HS • DC • RST • DCC

SBS 622

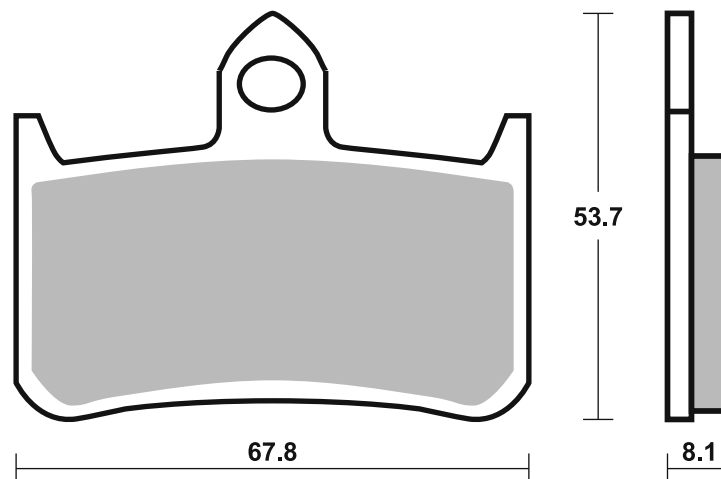

## Applications

## SBS 623

## Recommended compound



HONDA			
RVF	400 RR (NC35)	90 - 96	HF
VFR	400 R	89 - 92	LS
VTR	400 R (NC 30)	90 - 90	LS
RVF	750 RR (RC-45)	94 - 98	LS
VFR	750 R	88 - 93	LS

## SBS 624

## Recommended compound



MZ			
1000 (MUZ) S		03 - 10	HS
1000 (MUZ) SF		05 - 10	HS
1000 (MUZ) SFX		07 - 07	HS
1000 (MUZ) SN		05 - 05	HS
1000 (MUZ) ST		07 - 10	HS
NISSIN			
4 Piston Caliper			
SUZUKI			
RGV	250	88 - 88	HS
GSX-R	400 R	90 - 95	HS
GSX-R	600	92 - 93	HS
GSX-R	750	88 - 93	HS
GSX	1100 Katana	93 - 93	HS
GSX-R	1100	89 - 92	HS
GSF	1200 Bandit	95 - 96	HS
TRIUMPH			
600	Daytona	03 - 04	HS
600	Speed Four	03 - 06	HS
TT	600	00 - 03	HS
650	Daytona	05 - 06	HS
750	Daytona	91 - 92	HS
900	Daytona	91 - 98	HS
900	Speed Triple	94 - 96	HS
900	Sprint	94 - 98	HS
900	Trophy	96 - 03	HS
T509	900	Speed Triple	97 - 01



TRIUMPH			
T595	950	Daytona	96 - 98
	955	Daytona	
		Centennial	02 - 04
	955	Daytona from	
		VIN 132513	99 - 01
	955	Daytona to	
		VIN 132512	99 - 06
	955	Speed Triple	99 - 06
	955	Sprint RS	00 - 05
	955	Sprint ST	99 - 04
	1000	Daytona	92 - 92
	1050	Sprint GT ABS	10 - 15
	1050	Sprint GT SE	
		ABS	10 - 15
	1050	Sprint ST	05 - 11
	1200	Daytona	91 - 97
	1200	Tiger Explorer	12 - 15
	1200	Trophy	96 - 03
	1600	Thunderbird	09 - 18
	1700	Thunderbird	
		Commander	14 - 18
	1700	Thunderbird LT	14 - 18
	1700	Thunderbird	
		Nightstorm	14 - 18
	1700	Thunderbird	
		Storm	11 - 18
	2300	Rocket 3 Classic	07 - 13
	2300	Rocket 3	
		Roadster	10 - 18
	2300	Rocket 3 Touring	13 - 14
	2300	Rocket III	04 - 13



TRIUMPH			
	2300	Rocket X	15 - 15
YAMAHA			
TZ	125		97 - 00
TZ	250		90 - 05
FZR	750	R	89 - 92

STREET  
AMERICAN  
SCOOTER

HF • HS • LS  
H.HF • H.CT • H.HS • H.LS  
HF • CT • MS

RACING  
OFF ROAD  
ATV

RST • DC • DCC • DS-1 • DS-2 • RQ  
SI • RSI • CS  
ATS • SI • RSI • PSI

Drawings 1:1

Available compounds

HF • LS • RQ

SBS 623

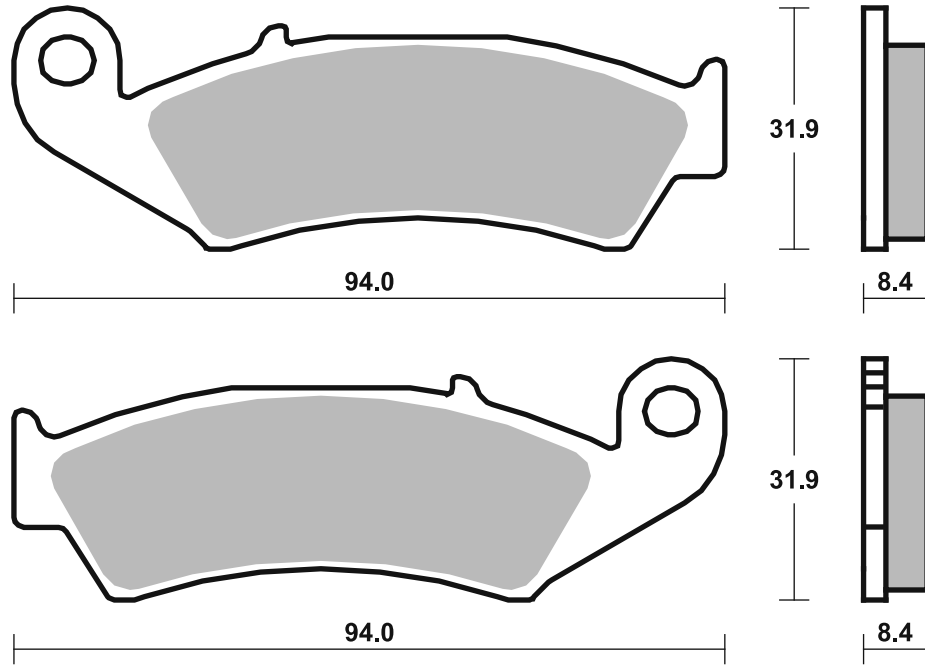

Available compounds

HF • HS • DC • RST • DCC

SBS 624

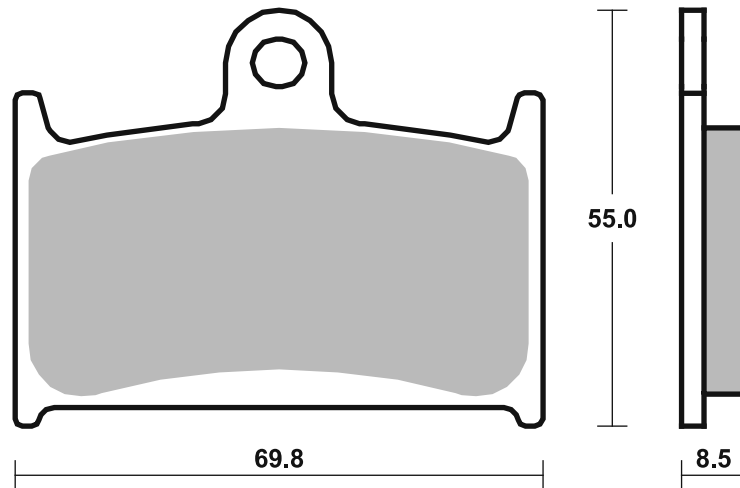



<b>SUZUKI</b>			
DR	600 Djebel	89 - 89	<b>HF</b>
DR	650	90 - 95	<b>HS</b>
DR	650 R	92 - 92	<b>HS</b>
DR	750 Big	89 - 90	<b>HS</b>
DR	750 S, Big	88 - 88	<b>HF</b>
DR	800 S, Big	90 - 90	<b>HS</b>
DR-Z	800	88 - 90	<b>HS</b>

STREET  
AMERICAN  
SCOOTER

HF • HS • LS  
H.HF • H.CT • H.HS • H.LS  
HF • CT • MS

RACING  
OFF ROAD  
ATV

RST • DC • DCC • DS-1 • DS-2 • RQ  
SI • RSI • CS  
ATS • SI • RSI • PSI

Drawings 1:1

Available compounds

HF • HS

SBS 626

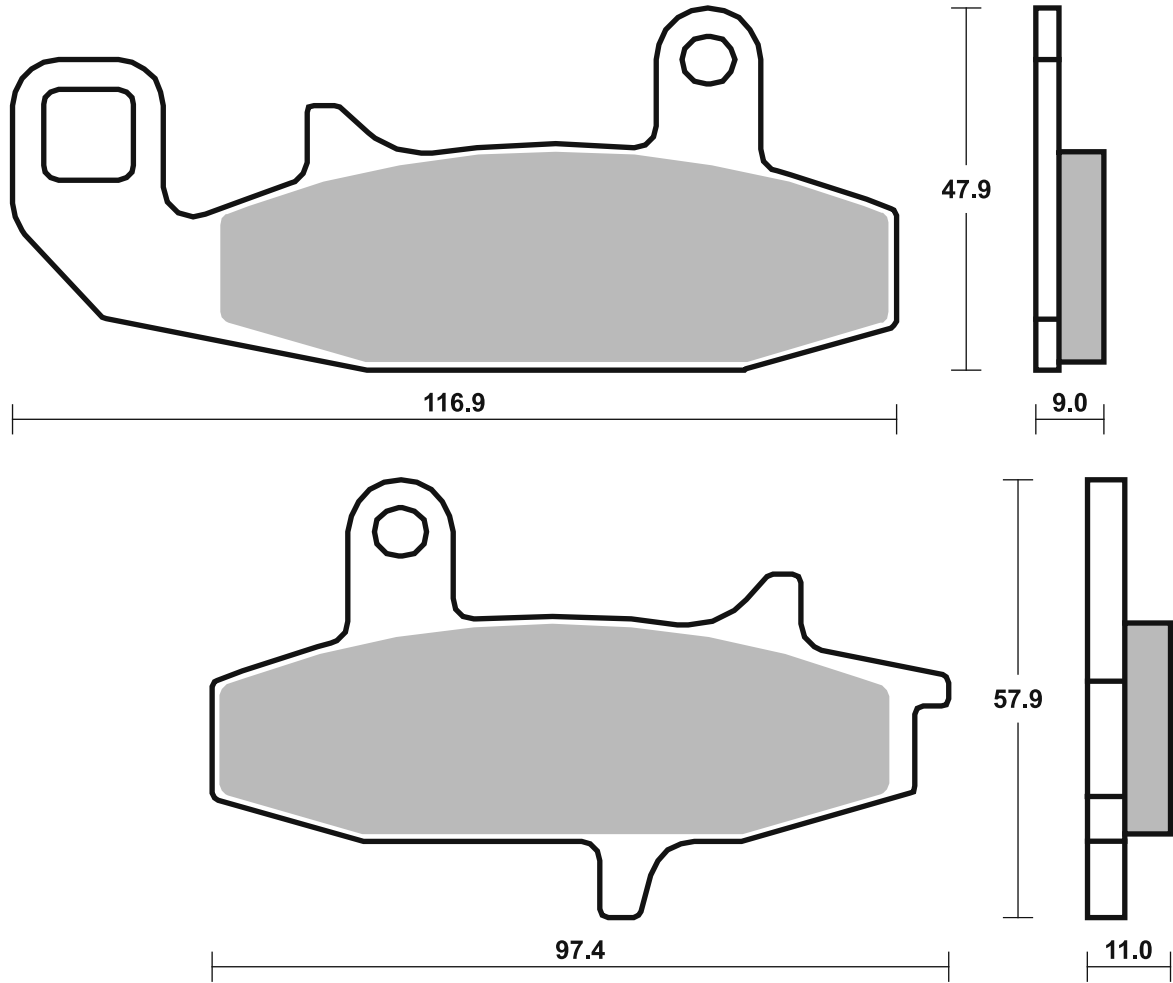



<b>BUELL</b>			
500 Blast	01 - 09	HF	

<b>CAGIVA</b>			
900 Gran Canyon	99 - 04	HS	
1000 Navigator, T	00 - 05	HS	

#### HONDA

RS 125 R	91 - 94	HF	
250 Steed	93 - 96	HF	
CB 250	92 - 05	HF	
CBR 250 Nighthawk	92 - 95	HF	
CBR 250 R (Nissin cal)	11 - 13	HS	
CBR 250 R, RR	90 - 90	HF	
CBR 250 RJ	88 - 88	HF	
VT 250 Spada	89 - 89	HF	
CB-1 400 (CB 400 F)	89 - 90	HS	
CBR 400 RR	87 - 89	HS	
NV 400 Steed	92 - 93	HS	
CB 500	94 - 96	HS	
600 Steed	92 - 02	HS	
CB 600 Hornet	98 - 12	HS	
CB 600 Hornet, S	00 - 03	HS	
CBF 600 N	04 - 11	HS	
CBF 600 S	04 - 11	HS	
CBR 600 F	11 - 13	HS	
CBR 600 F3	95 - 98	HS	
VT 600 C, Shadow	94 - 00	HS	
VT 600 CD Shadow VLX	94 - 00	HS	
CB 650 F	14 - 19	HS	
CBR 650 F	14 - 20	HS	
FMX 650 Rally	05 - 08	HS	
NT 650 Hawk GT	88 - 91	HS	
NTV 650 Revere	88 - 93	HS	
NC 700 S	12 - 13	HS	
NC 700 X	12 - 13	HS	
VFR 700 F Interceptor	88 - 89	HS	
CB 750 N, F, Seven Fifty	92 - 95	HS	
VFR 750 F	88 - 98	HS	
PC 800 Pacific Coast	89 - 97	HS	
VFR 950 F, Carat	92 - 92	HS	
CBR 1000 F	89 - 92	HS	
VFR 1000	89 - 89	HS	
ST 1100	90 - 02	HS	
ST 1100 ABS-TCS	92 - 95	HS	
VT 1100 C Shadow	94 - 96	HS	
VT 1100 C2 Shadow			
A.C.E.	95 - 04	HS	
VT 1100 C2 Y	00 - 05	HS	
VT 1100 C3 Shadow Aero	98 - 04	HS	
VT 1100 T Shadow	98 - 04	HS	
VT 1300 CX A Fury	10 - 22	HS	
VTX 1300 C	04 - 09	HS	
VTX 1300 S	03 - 07	HS	
GL 1500 F6 C Valkyrie	96 - 02	HS	

<b>HYOSUNG</b>			
125 V2	99 - 11	HF	
250 Aquila	00 - 09	HF	

<b>KAWASAKI</b>			
KLE 300 Versys-X	17 - 23	HS	
451 7 HEV	24 - 24	HS	
451 Ninja 7 HEV	24 - 24	HS	
EX 650 Ninja ABS	17 - 23	HS	
EX 650 Ninja			
Performance ABS	17 - 23	HS	
EX 650 Ninja Tourer ABS	17 - 23	HS	
KLE 650 Versys	15 - 24	HS	
KLE 650 Versys ABS	15 - 23	HS	
KLE 650 Versys LT	15 - 16	HS	



<b>KAWASAKI</b>			
Z 650 ABS	17 - 24	HS	
Z 650 RS	22 - 24	HS	
Z 750 , ABS	07 - 12	HS	
Z 800 e	13 - 16	HS	

<b>KYMCO</b>			
250 Venox	01 - 14	HF	HF

<b>MASH</b>			
400 Scrambler	13 - 17	HS	
500 Five Hundred	13 - 16	HS	

<b>MBP</b>			
C 650 V	23 - 23	HS	

<b>SUZUKI</b>			
250 Impulse	95 - 95	HS	
DL 250 V-Strom	17 - 23	HF	
GSX-R 250	17 - 23	HF	
GW 250 Inazuma	12 - 19	HS	
GW 250 Inazuma F	15 - 19	HS	
GSX 400 Impulse	94 - 96	HS	
RF 400 RVC	93 - 97	HS	
GSF 600 Bandit	95 - 99	HS	
RF 600 R	93 - 96	HS	
DL 800 V-Strom DE	23 - 24	HS	
C 1500 T Intruder	13 - 18	HS	

<b>SWM</b>			
440 Gran Milano	15 - 17	HS	
440 Gran Turismo	15 - 17	HS	
440 Silver Vase	15 - 17	HS	

<b>TRIUMPH</b>			
660 Street Triple S	17 - 20	HS	
660 Tiger Sport	22 - 23	HS	
660 Trident	21 - 23	HS	
675 Street Triple	08 - 17	HS	
765 Street Triple S	17 - 20	HS	
800 America	03 - 06	HS	
800 Bonneville	01 - 04	HS	
800 Bonneville			
America	02 - 06	HS	
800 Bonneville			
Speedmaster	03 - 04	HS	
800 Bonneville T100			
Centennial			
Edition	02 - 04	HS	
800 Bonneville T100			
Paul Smith	06 - 08	HS	
800 Tiger	11 - 14	HS	
800 Tiger XC	11 - 17	HS	
800 Tiger XC ABS	12 - 14	HS	
800 Tiger XCA	15 - 17	HS	
800 Tiger XCR	15 - 17	HS	
800 Tiger XR	15 - 18	HS	
800 Tiger XRT	15 - 17	HS	
800 Tiger XRX	15 - 17	HS	
900 Adventurer	96 - 02	HS	
900 America	07 - 16	HS	
900 Bonneville	05 - 11	HS	
900 Bonneville			
Newchurch	15 - 15	HS	
900 Bonneville SE	09 - 13	HS	
900 Bonneville			
Speedmaster	05 - 15	HS	
900 Bonneville Spirit	15 - 15	HS	
900 Bonneville			
Street Cup	17 - 18	HS	
900 Bonneville T100	05 - 20	HS	



<b>TRIUMPH</b>			
900 Bonneville T100			
Black	16 - 20	HS	
900 Bonneville T214	15 - 15	HS	
900 Legend TT	99 - 01	HS	
900 Scrambler	06 - 16	HS	
900 Street Cup	17 - 20	HS	
900 Street Scrambler	17 - 18	HS	
900 Street Twin	16 - 18	HS	
900 T100 Bud Ekins	20 - 20	HS	
900 Thruxton	04 - 05	HS	
900 Thruxton Ace	15 - 15	HS	
900 Thunderbird	96 - 05	HS	
900 Thunderbird			
Sport	03 - 04	HS	
900 Tiger	99 - 00	HS	
955 Tiger	01 - 06	HS	LS
955 Tiger	04 - 06	HS	
1200 Bonneville			
Bobber	17 - 20	HS	
1200 Bonneville T120	16 - 20	HS	
1200 Bonneville T120			
Ace	19 - 20	HS	
1200 Bonneville T120			
Black	16 - 20	HS	
1200 Bonneville T120			
Diamond Ed.	19 - 20	HS	
1200 Scrambler X	24 - 24	HS	
1200 T120 Bud Ekins	20 - 20	HS	
1200 Thruxton	16 - 19	HS	

<b>VOGE</b>			
500 R	23 - 23	HS	
AC 500	23 - 23	HS	
DS 500	23 - 23	HS	
DSX 500	23 - 23	HS	
525 Brivido R	24 - 24	HS	
525 Trofeo ACX	24 - 24	HS	
525 Valico DSX	24 - 24	HS	
DSX 650	23 - 23	HS	

<b>VOXAN</b>			
1000 Scrambler	01 - 03	HF	

<b>YAMAHA</b>			
WR 125 R, XY	09 - 16	HF	
WR 250 X	08 - 16	HS	

STREET  
AMERICAN  
SCOOTER

HF • HS • LS  
H.HF • H.CT • H.HS • H.LS  
HF • CT • MS

RACING  
OFF ROAD  
ATV

RST • DC • DCC • DS-1 • DS-2 • RQ  
SI • RSI • CS  
ATS • SI • RSI • PSI

Available compounds

HF • HS • LS • DC • RST • DCC

SBS 627

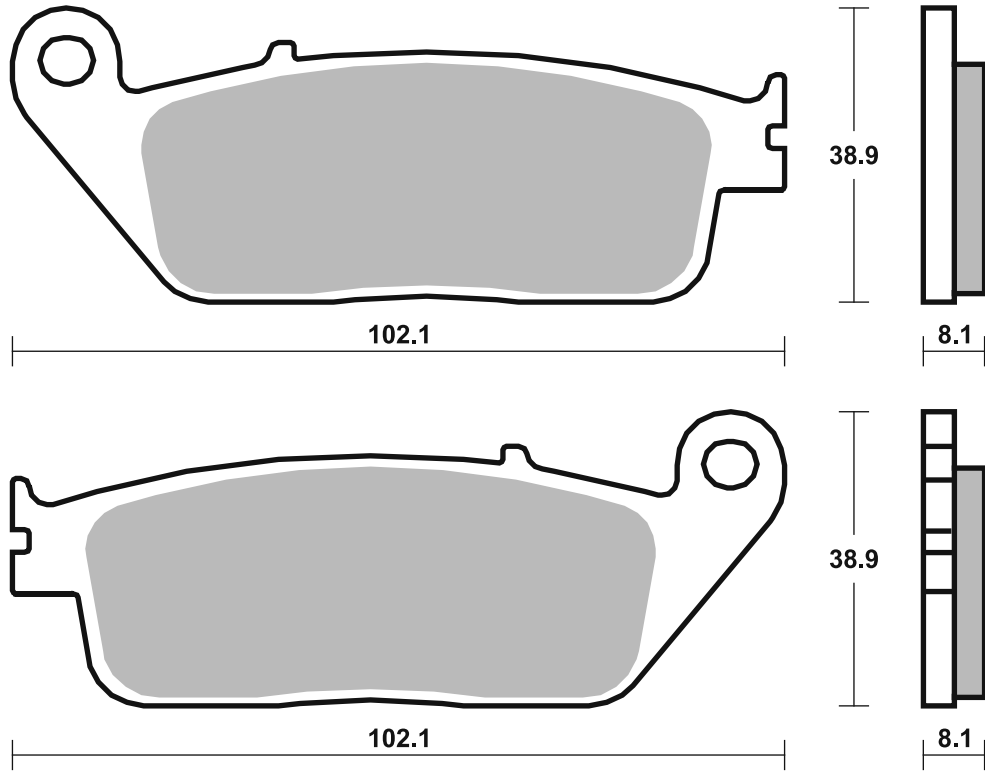

## Applications

### SBS 628

### Recommended compound



HONDA			
Lead	80 SS	85 - 85	HF

### SBS 629

### Recommended compound



HONDA			
TLM	220	89 - 91	HF
AX-1	250	90 - 90	HF
CRM	250 R	90 - 90	HF
XLR	250 R Baja	88 - 90	SI
TLM	260 R	90 - 90	HF

Brake Pad 1:1 Drawings, Compounds, Fitments



STREET  
AMERICAN  
SCOOTER

HF • HS • LS  
H.HF • H.CT • H.HS • H.LS  
HF • CT • MS

RACING  
OFF ROAD  
ATV

RST • DC • DCC • DS-1 • DS-2 • RQ  
SI • RSI • CS  
ATS • SI • RSI • PSI

Available compounds

HF

SBS 628

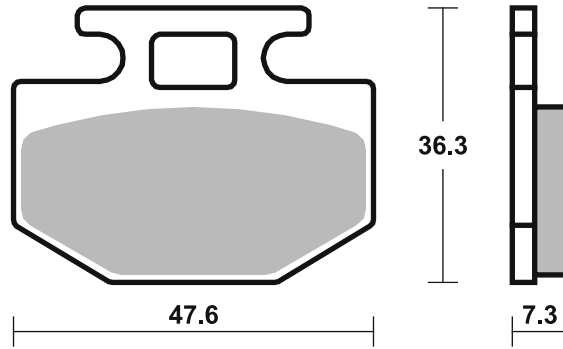

Available compounds

HF • SI • RSI

SBS 629

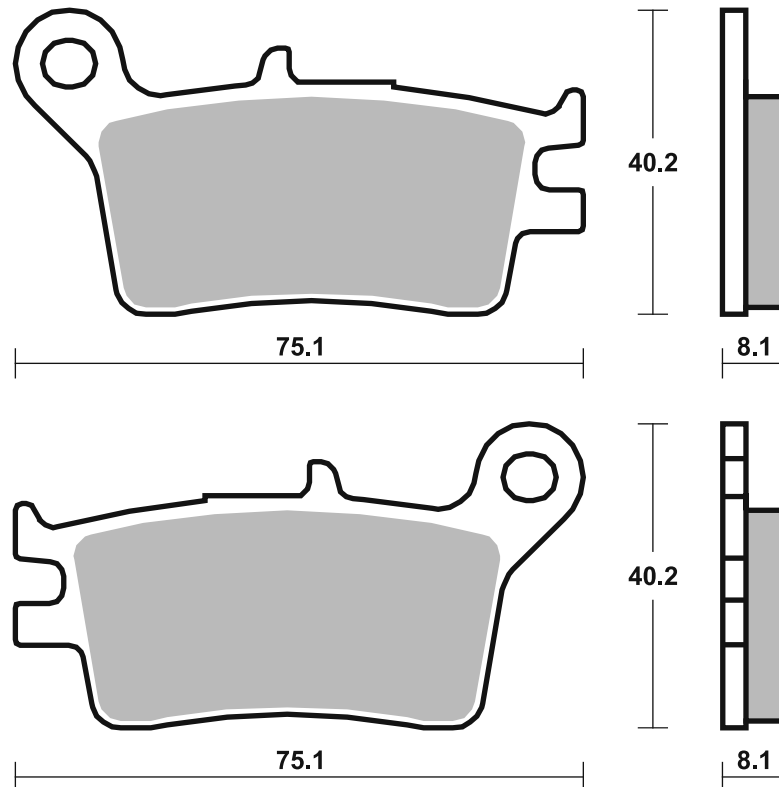

## Applications

### SBS 631

### Recommended compound



<b>BERINGER</b>			
4 Piston Caliper			
<b>HUSABERG</b>			
FS	400 e, c	01 - 03	<b>RSI</b>
FS	450 e, c	03 - 05	<b>RSI</b>
FS	650 e, c	01 - 05	<b>RSI</b>
<b>KAWASAKI</b>			
KR-1	250 S	90 - 90	<b>HF</b>
ZR	400 Zephyr	97 - 01	<b>HS</b>
ZX-4	400	90 - 90	<b>HS</b>
ZXR	400	89 - 90	<b>HF</b>
ZZR	400	90 - 94	<b>HS</b>
GPZ	500	93 - 94	<b>HS</b>
ZZR	500 (Austria)	90 - 98	<b>HS</b>
	600 R, Ninja	89 - 96	<b>HF</b>
ZX	600 Ninja	90 - 93	<b>HS</b>
ZX-6R	600 (Ninja ZX6)	93 - 97	<b>HS</b>
ZX-6R	600 (Ninja ZX6R)	95 - 97	<b>HS</b>
ZX-6R	600 (ZX6)	90 - 93	<b>HS</b>
ZZR	600	90 - 07	<b>HS</b>
ZX-7R	750 Ninja	89 - 95	<b>HS</b>
ZXR	750 R	89 - 95	<b>HS</b>
GPZ	900 R Ninja	90 - 96	<b>HS</b>
ZX-9R	900 Ninja	94 - 95	<b>HS</b>
KLE	1000 Versys	12 - 18	<b>HS</b>
KLE	1000 Versys ABS	15 - 18	<b>HS</b>
KLE	1000 Versys LT	15 - 16	<b>HS</b>
ZR	1100 Zephyr	92 - 95	<b>HS</b>
ZX	1100	93 - 97	<b>HS</b>
ZZR	1100	90 - 01	<b>HS</b>
ZZR	1200	02 - 04	<b>HS</b>
VN	1700 Voyager	09 - 16	<b>HS</b>



<b>KAWASAKI</b>			
VN	2000	04 - 10	<b>HS</b>
<b>MOTO-MASTER</b>			
Supermoto Racing Caliper			
<b>SUZUKI</b>			
RG	125 F, Gamma	92 - 96	<b>HF</b>
RG	200 Gamma	91 - 94	<b>HS</b>
	250 Cobra	90 - 92	<b>HS</b>
	250 Wolf	90 - 92	<b>HS</b>
GSX-R	250 R	89 - 91	<b>HS</b>
RGV	250	89 - 90	<b>HF</b>
RGV	250	93 - 95	<b>HF</b>
RGV	250 Gamma	91 - 92	<b>HF</b>
TV	250	88 - 88	<b>HF</b>
	350 Goose	92 - 99	<b>HF</b>
GSF	400 Bandit	93 - 97	<b>HS</b>
GSX	400 S, Katana	92 - 92	<b>HS</b>
GSX-R	400	88 - 89	<b>HF</b>
GSR	600	06 - 10	<b>HS</b>
GSX-R	600	97 - 03	<b>HS</b>
GSF	650 Bandit	07 - 11	<b>HS</b>
GSF	650 Bandit ABS	07 - 12	<b>HS</b>
GSF	650 S Bandit	07 - 11	<b>HS</b>
GSF	650 S Bandit ABS	07 - 13	<b>HS</b>
GSX	650 F	08 - 18	<b>HS</b>
SV	650	19 - 24	<b>HS</b>
SV	650 X	19 - 24	<b>HS</b>
GSX-R	750	00 - 03	<b>HS</b>
SV	1000 , S	03 - 07	<b>HS</b>
TL	1000 S V-Twin	97 - 01	<b>HS</b>
GSF	1200 Bandit	06 - 06	<b>HS</b>
GSF	1200 S Bandit	06 - 06	<b>HS</b>



<b>SUZUKI</b>			
GSF	1250 A Bandit	07 - 18	<b>HS</b>
GSF	1250 Bandit	06 - 18	<b>HS</b>
GSF	1250 F Bandit	12 - 18	<b>HS</b>
GSF	1250 S Bandit	06 - 18	<b>HS</b>
GSF	1250 SA Bandit	07 - 18	<b>HS</b>
GSX	1250 FA Bandit	16 - 18	<b>HS</b>
GSX	1250 FA Traveller	15 - 16	<b>HS</b>

### SBS 632

### Recommended compound



<b>CANNONDALE</b>			
MX	400	00 - 03	<b>RSI</b>
C	440 R	03 - 03	<b>RSI</b>
E	440 , A, R	03 - 03	<b>RSI</b>
S	440	03 - 03	<b>HF</b>
X	440	03 - 03	<b>RSI</b>
<b>KAWASAKI</b>			
KDX	125	90 - 94	<b>SI</b>
KX	125	89 - 94	<b>RSI</b>
KDX	200	93 - 99	<b>SI</b>
KDX	200 SR	89 - 92	<b>SI</b>
KDX	220 R	97 - 05	<b>SI</b>
KDX	250 SR	91 - 94	<b>SI</b>
KLX	250	93 - 96	<b>SI</b>
KX	250	89 - 94	<b>RSI</b>
KX	500	89 - 95	<b>RSI</b>
KLX	650	93 - 96	<b>SI</b>
KLX	650 R	93 - 95	<b>SI</b>
<b>SUZUKI</b>			
RM	125	89 - 90	<b>RSI</b>
TS	125	89 - 96	<b>HF</b>
TS	200 R	90 - 94	<b>HF</b>
	250 Djebel	93 - 95	<b>HF</b>
DR	250	90 - 95	<b>HF</b>
RM	250	89 - 90	<b>RSI</b>
<b>YAMAHA</b>			
FZR	50	92 - 92	<b>HF</b>



<b>YAMAHA</b>			
YD	80	89 - 89	<b>HF</b>
DT	125 X Supermotard	05 - 08	<b>HF</b>
MT	125	20 - 24	<b>HF</b>
WR	125	91 - 97	<b>SI</b>
XSR	125	22 - 24	<b>HF</b>
YZ	125	90 - 95	<b>RSI</b>
YZF	125 R	19 - 24	<b>HF</b>
MT-15	155	18 - 21	<b>HF</b>
YZF	155 R	19 - 21	<b>HF</b>
DT	200 WR	91 - 93	<b>HF</b>
WR	200	91 - 92	<b>SI</b>
FZ25	250	19 - 19	<b>HF</b>
TT	250	93 - 03	<b>SI</b>
TY	250 Z (Scottish)	96 - 96	<b>RSI</b>
WR	250	90 - 97	<b>SI</b>
XG	250 Tricker	05 - 11	<b>HF</b>
XT	250	08 - 22	<b>HF</b>
YZ	250 A	90 - 90	<b>RSI</b>
YZ	250 WRA,WRB	90 - 91	<b>RSI</b>
TT	350	95 - 00	<b>SI</b>
WR	500 ZD,ZE	92 - 93	<b>SI</b>
TT	600 R	93 - 95	<b>HF</b>

STREET  
AMERICAN  
SCOOTER

HF • HS • LS  
H.HF • H.CT • H.HS • H.LS  
HF • CT • MS

RACING  
OFF ROAD  
ATV

RST • DC • DCC • DS-1 • DS-2 • RQ  
SI • RSI • CS  
ATS • SI • RSI • PSI

Drawings 1:1

Available compounds

HF • HS • DC • RST • DCC • DS-1 • RSI

SBS 631

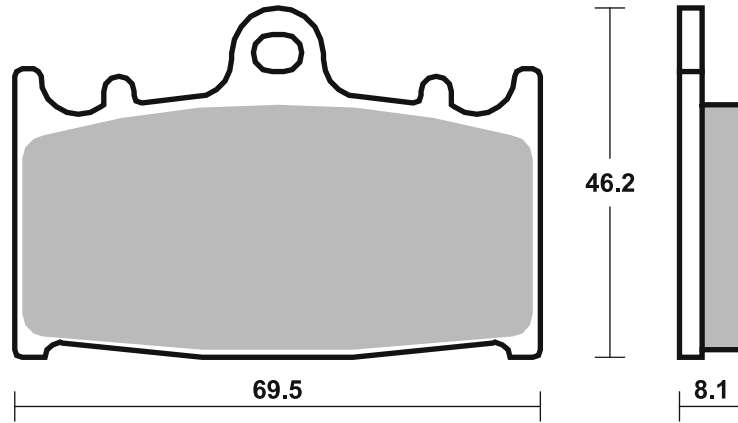

Available compounds

HF • SI • RSI

SBS 632

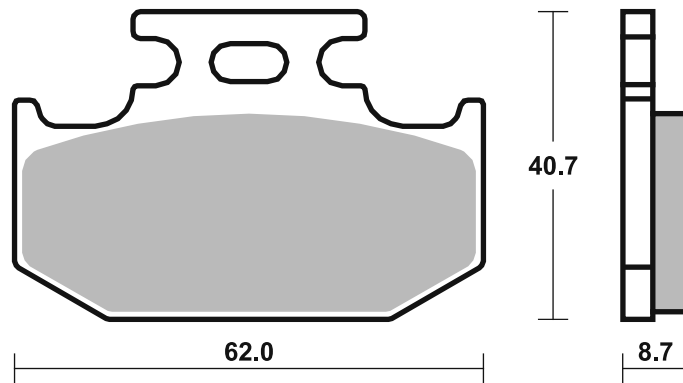

## Applications

### SBS 633

### Recommended compound



<b>MZ</b>			
	125 SM, SX	99 - 08	<b>HF</b>
RT	125	06 - 08	<b>HF HF</b>
<b>TRIUMPH</b>			
	750 Daytona	91 - 92	<b>LS</b>
	900 Daytona	91 - 93	<b>LS</b>
	900 Daytona Super III	94 - 98	<b>LS</b>
	900 Trophy	96 - 03	<b>LS</b>
	1000 Daytona	92 - 92	<b>LS</b>
	1200 Daytona	91 - 97	<b>LS</b>
	1200 Trophy	96 - 03	<b>LS</b>
<b>VOXAN</b>			
	1000 Scrambler	01 - 03	<b>HF</b>
<b>YAMAHA</b>			
XTZ	750 Super Tenere	89 - 95	<b>HF</b>

### SBS 634

### Recommended compound



<b>KTM</b>			
RC	250 Upgrade DS	14 - 15	<b>RST</b>
RC	390 Upgrade DS	14 - 23	<b>RST</b>
<b>YAMAHA</b>			
TZR	125	94 - 94	<b>HF</b>
TZR	125 R	94 - 04	<b>HF</b>
TZR	250	89 - 92	<b>HF</b>
FZR	400 R	91 - 94	<b>HS</b>
FZ6	600 Fazer S2	07 - 09	<b>HS</b>
FZ6	600 Fazer S2 ABS	07 - 09	<b>HS</b>
FZ6	600 S2	07 - 09	<b>HS</b>
FZ6	600 S2 ABS	07 - 09	<b>HS</b>
FZS	600 Fazer	98 - 03	<b>HS</b>
FZS	600 S Fazer	01 - 03	<b>HS</b>
YZF	600 R Thunder Cat	96 - 03	<b>HS</b>
YZF	600 R6	99 - 16	<b>HS</b>
	700 Tracer 7	21 - 24	<b>HS</b>
	700 Tracer 7 GT	21 - 24	<b>HS</b>
MT-07	700	14 - 24	<b>HS</b>
MT-07	700 Moto Cage	15 - 17	<b>HS</b>
MT-07	700 SP	18 - 18	<b>HS</b>
MT-07	700 Tracer	16 - 20	<b>HS</b>
MT-07	700 Tracer GT	19 - 19	<b>HS</b>
XSR	700	16 - 24	<b>HS</b>
XSR	700 XTribute	19 - 22	<b>HS</b>
YZF	700 R7	22 - 24	<b>HS</b>
YZF	750 R7 OW02	99 - 02	<b>HS</b>
	800 Fazer 8	10 - 15	<b>HS</b>
FZ8	800	10 - 14	<b>HS</b>
MXT	850 Niken	18 - 24	<b>HS</b>
MXT	850 Niken GT	19 - 24	<b>HS</b>



<b>YAMAHA</b>			
	900 Tracer 9	15 - 24	<b>HS</b>
	900 Tracer 9 GT	18 - 24	<b>HS</b>
MT-09	900	14 - 24	<b>HS</b>
MT-09	900 SP	18 - 23	<b>HS</b>
MT-09	900 Sport Tracker	15 - 16	<b>HS</b>
MT-09	900 Street Rally	14 - 16	<b>HS</b>
TDM	900	02 - 14	<b>HS</b>
XSR	900	16 - 24	<b>HS</b>
XSR	900 Abarth	17 - 22	<b>HS</b>
XSR	900 GP	24 - 24	<b>HS</b>
FZ1	1000 Fazer	06 - 16	<b>HS</b>
FZS	1000 Fazer	01 - 05	<b>HS</b>
MT-10	1000	16 - 24	<b>HS</b>
MT-10	1000 SP	17 - 24	<b>HS</b>
MT-10	1000 Tourer Ed.	17 - 19	<b>HS</b>
YZF	1000 R Thunder Ace	96 - 99	<b>HS</b>
YZF	1000 R1	98 - 03	<b>HS</b>
YZF	1000 R1	15 - 24	<b>HS</b>
YZF	1000 R1 SP	06 - 06	<b>HS</b>
YZF	1000 R1M	15 - 24	<b>HS</b>
YZF	1000 R1S	16 - 16	<b>HS</b>
BT	1100 Bulldog	02 - 06	<b>HS</b>
XT	1200 Z Super Tenere	14 - 19	<b>HS</b>
XT	1200 ZE Super Tenere	14 - 19	<b>HS</b>
XT	1200 ZE Super Tenere		
	Raid Ed.	18 - 19	<b>HS</b>
XTZ	1200 Super Tenere	10 - 13	<b>HS</b>
FJR	1300	01 - 03	<b>HS</b>
FJR	1300 ABS	03 - 05	<b>HS</b>
XJR	1300	99 - 18	<b>HS</b>
XJR	1300 Racer	15 - 19	<b>HS</b>



<b>YAMAHA</b>			
XJR	1300 SP	01 - 01	<b>HS</b>
MT-01	1700	05 - 06	<b>HS</b>
XV	1700 PC Road Star		
	Warrior	03 - 07	<b>HS</b>
XV	1700 Road Star		
	Warrior	02 - 02	<b>HS</b>
XV	1900 A Midnight Star	06 - 10	<b>HS</b>

STREET  
AMERICAN  
SCOOTER

HF • HS • LS  
H.HF • H.CT • H.HS • H.LS  
HF • CT • MS

RACING  
OFF ROAD  
ATV

RST • DC • DCC • DS-1 • DS-2 • RQ  
SI • RSI • CS  
ATS • SI • RSI • PSI

Drawings 1:1

Available compounds

HF • LS • SI • RSI

SBS 633

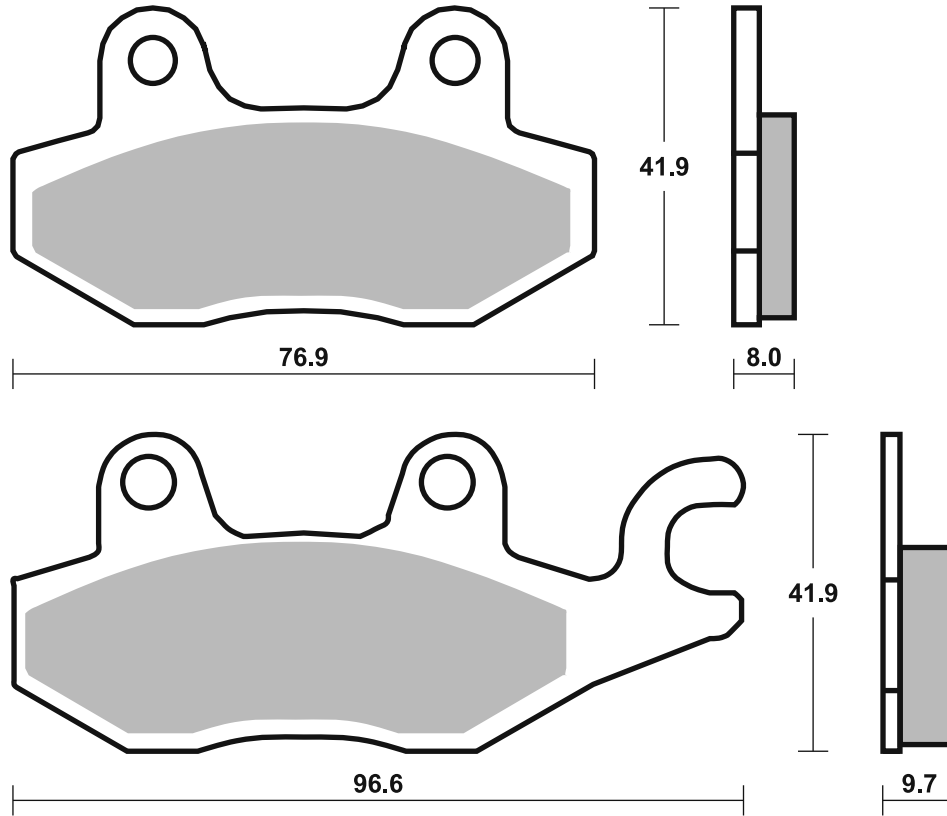

Available compounds

HF • HS • DC • RST • DS-1 • DS-2

SBS 634

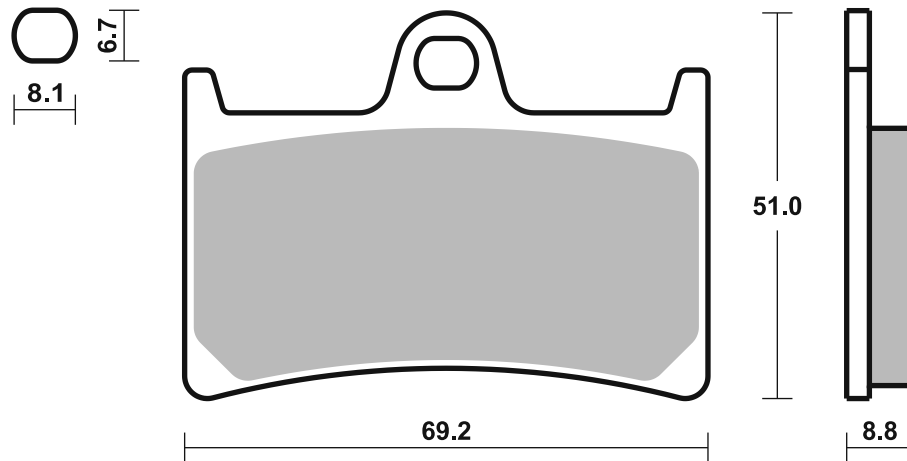



STREET  
AMERICAN  
SCOOTER

HF • HS • LS  
H.HF • H.CT • H.HS • H.LS  
HF • CT • MS

RACING  
OFF ROAD  
ATV

RST • DC • DCC • DS-1 • DS-2 • RQ  
SI • RSI • CS  
ATS • SI • RSI • PSI

Drawings 1:1

Available compounds

HF • LS

SBS 635

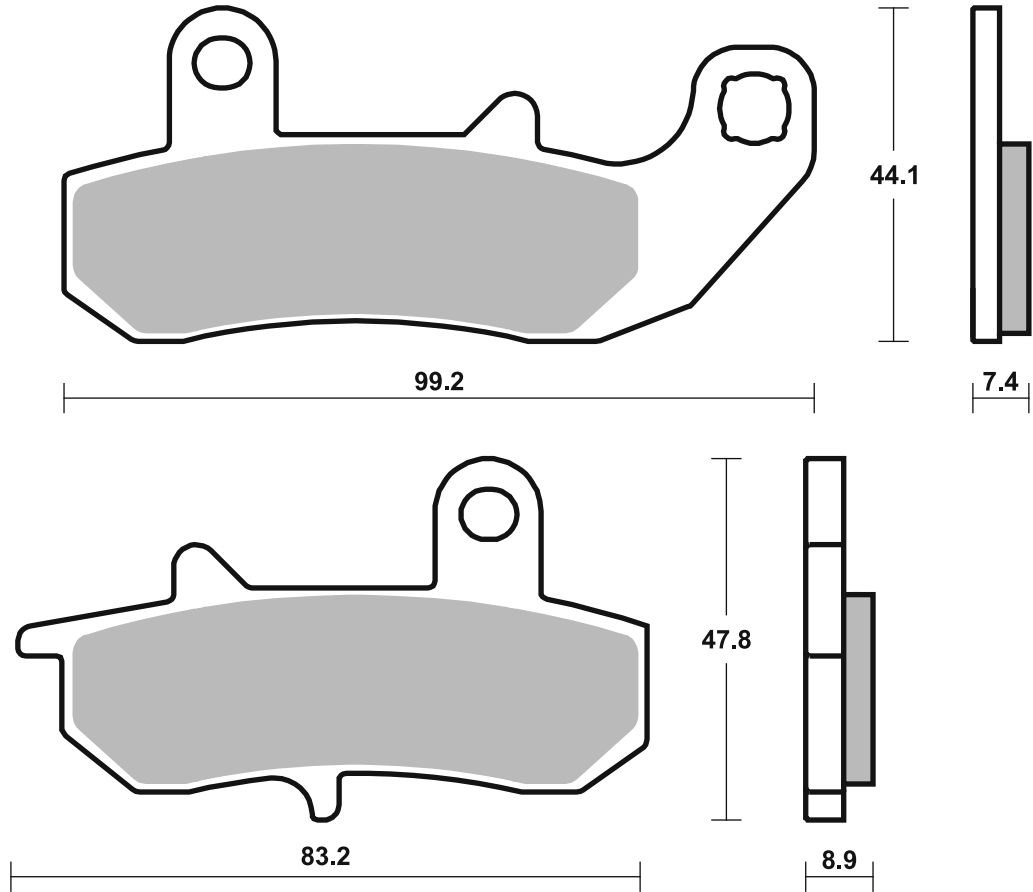

Available compounds

HF

SBS 636

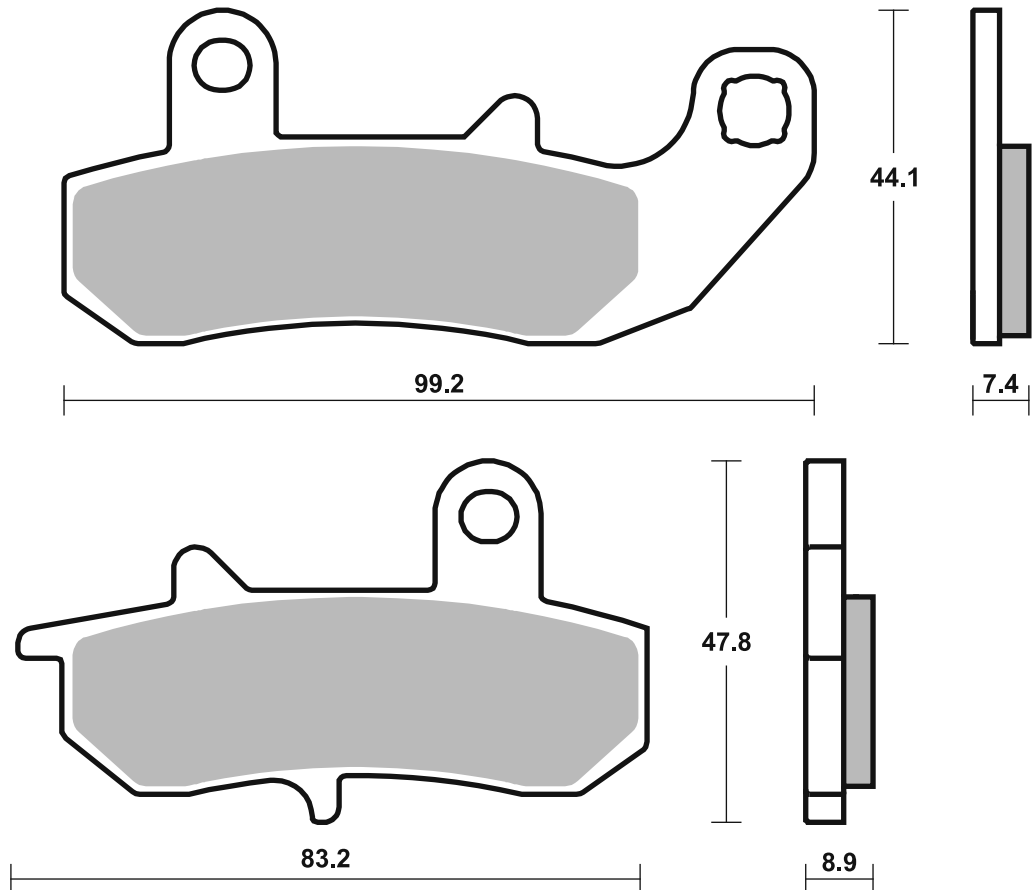

Dimensions in mm / Dimensions en mm  
1" = 25.4 mm, 1 mm = 0.04"





STREET  
AMERICAN  
SCOOTER

HF • HS • LS  
H.HF • H.CT • H.HS • H.LS  
HF • CT • MS

RACING  
OFF ROAD  
ATV

RST • DC • DCC • DS-1 • DS-2 • RQ  
SI • RSI • CS  
ATS • SI • RSI • PSI

Drawings 1:1

Available compounds

HF • SI • RSI

SBS 637

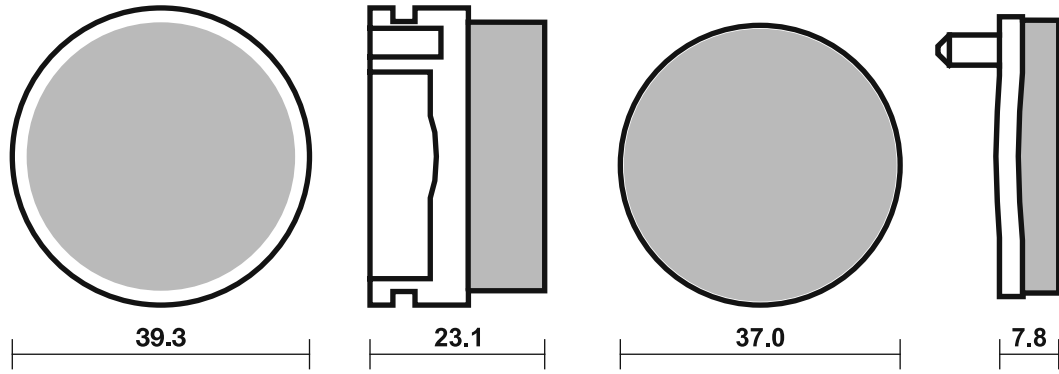

Available compounds

HF • HS • LS • DC • RST • DS-1 • RQ • SI • RSI • PSI

SBS 638

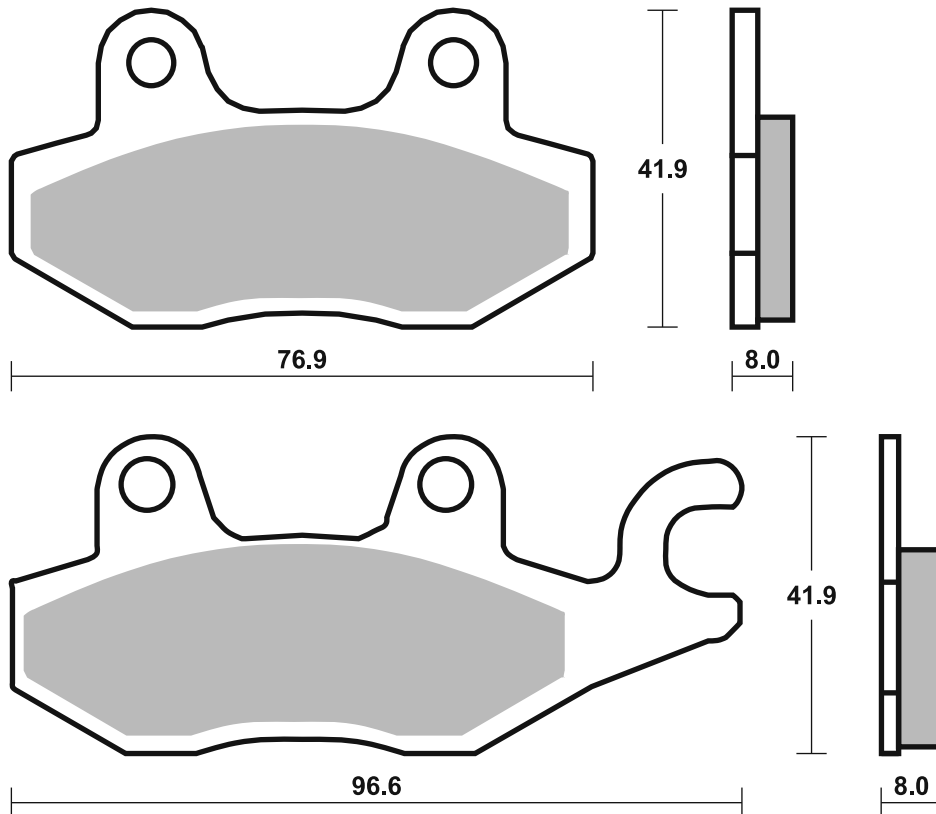

## Applications

### SBS 638

### Recommended compound



<b>KREIDLER</b>			
125 Florett RMC-F	07 - 08	<b>HF</b>	

<b>MOTOR UNION</b>			
HK 250 Haoke	97 - 99	<b>HF</b>	

<b>SUZUKI</b>			
LT-F 300 King Quad	02 - 02	<b>SI</b>	
LT-R 450	06 - 12	<b>SI</b>	
LT-A 500 FY Quadmaster	00 - 08	<b>SI</b>	
LT-F 500 F	98 - 07	<b>SI</b>	
DR 800 S, Big	91 - 95	<b>LS</b>	
DR 800 ST Big	96 - 98	<b>LS</b>	

<b>TRIUMPH</b>			
750 Trident	91 - 98	<b>HS</b>	
900 Bonneville	05 - 08	<b>LS</b>	
900 Daytona	94 - 98	<b>LS</b>	
900 Daytona, Sprint	93 - 93	<b>HS</b>	
900 Speed Triple	94 - 96	<b>LS</b>	
900 Sprint	94 - 98	<b>LS</b>	
900 Tiger	93 - 98	<b>HS</b>	
900 Trident	91 - 98	<b>HS</b>	
900 Trophy	91 - 95	<b>HS</b>	
955 Tiger	04 - 06	<b>LS</b>	
1000 Trophy	91 - 95	<b>HS</b>	
1050 Tiger	07 - 13	<b>LS</b>	
1050 Tiger SE	09 - 13	<b>LS</b>	
1200 Trophy	91 - 95	<b>HS</b>	

<b>VOGE</b>			
125 Brivido R	24 - 24	<b>HS</b>	



<b>VOGE</b>			
350 Trofeo AC	24 - 24	<b>HS</b>	

<b>YAMAHA</b>			
FZR 50	90 - 91	<b>HF</b>	
YBR 250	07 - 11	<b>HF</b>	
YFZ 450 S	04 - 09	<b>SI</b>	
YXR 450 Rhino	06 - 09	<b>SI</b>	
660 Rhino	05 - 08	<b>SI</b>	
YFM 700 R Raptor	06 - 08	<b>SI</b>	
YFM 700 Raptor	09 - 14	<b>SI</b>	
YXR 700 Rhino	08 - 14	<b>SI</b>	<b>SI</b>
XTZ 750 Super Tenere	89 - 95	<b>HF</b>	

### SBS 639

### Recommended compound



<b>YAMAHA</b>			
FZR 250 R	89 - 99	<b>HF</b>	
R1-Z 250	90 - 92	<b>HF</b>	

STREET  
AMERICAN  
SCOOTER

HF • HS • LS  
H.HF • H.CT • H.HS • H.LS  
HF • CT • MS

RACING  
OFF ROAD  
ATV

RST • DC • DCC • DS-1 • DS-2 • RQ  
SI • RSI • CS  
ATS • SI • RSI • PSI

Drawings 1:1

Available compounds

HF • HS • LS • DC • RST • DS-1 • RQ • SI • RSI • PSI

SBS 638

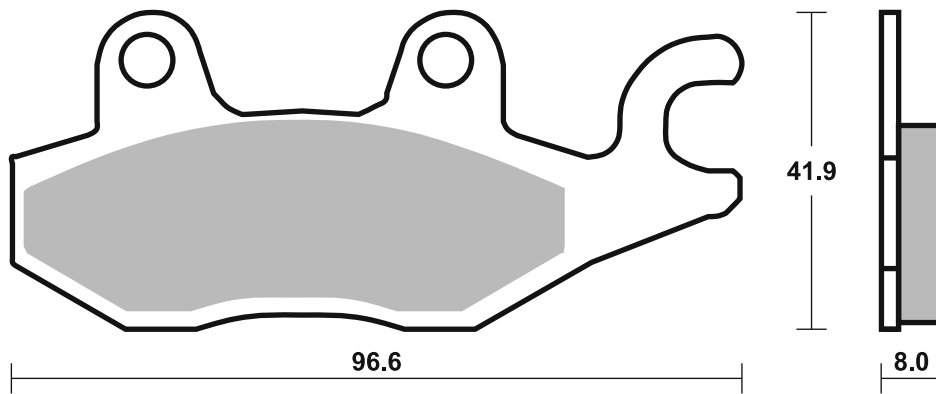
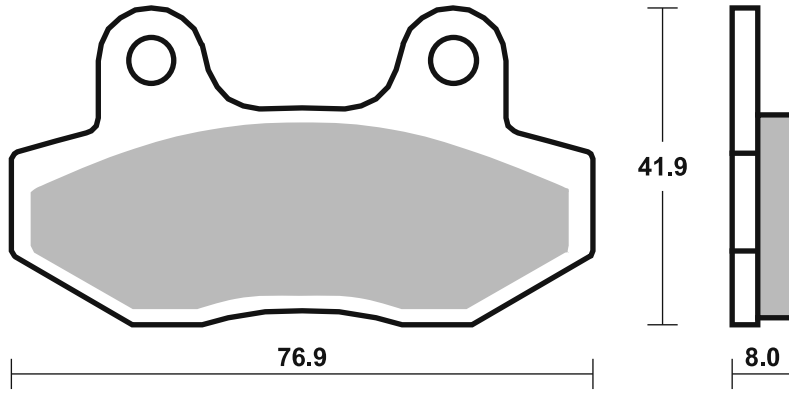

Available compounds

HF

SBS 639

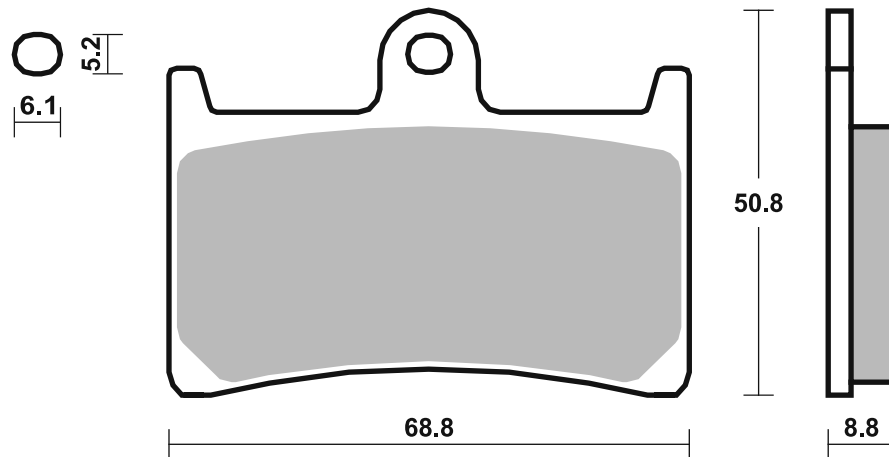



STREET  
AMERICAN  
SCOOTER

HF • HS • LS  
H.HF • H.CT • H.HS • H.LS  
HF • CT • MS

RACING  
OFF ROAD  
ATV

RST • DC • DCC • DS-1 • DS-2 • RQ  
SI • RSI • CS  
ATS • SI • RSI • PSI

Drawings 1:1

Available compounds

HF • HS

SBS 640

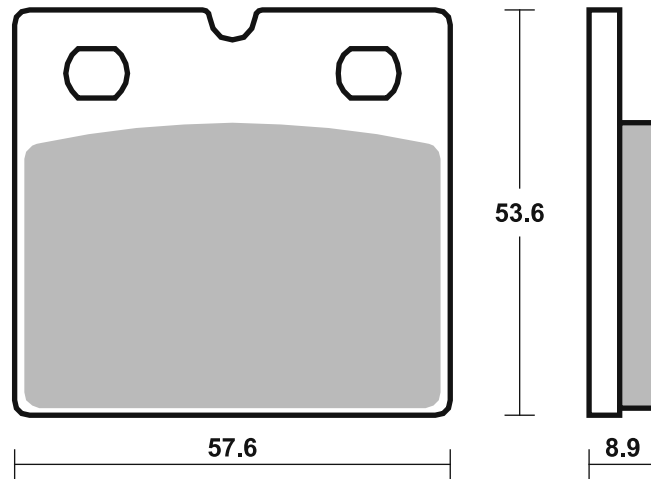

Available compounds

HF

SBS 641

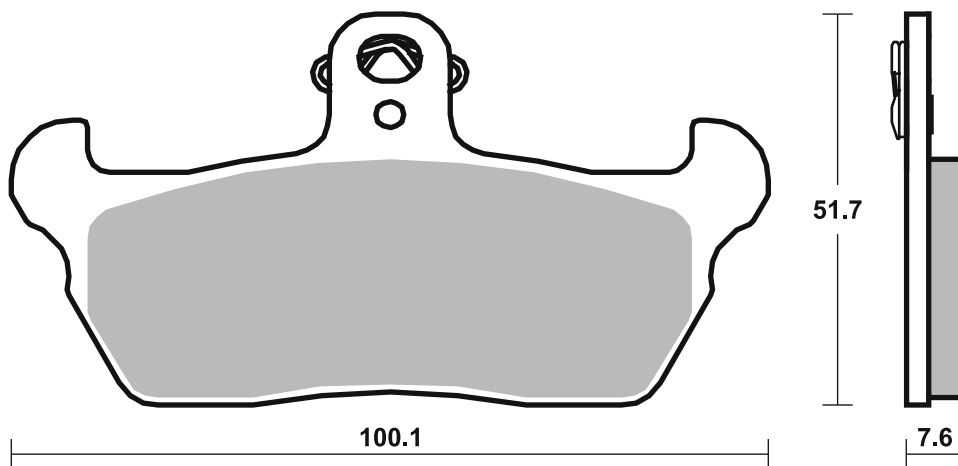

Available compounds

HF • SI • RSI • ATS • PSI

SBS 642

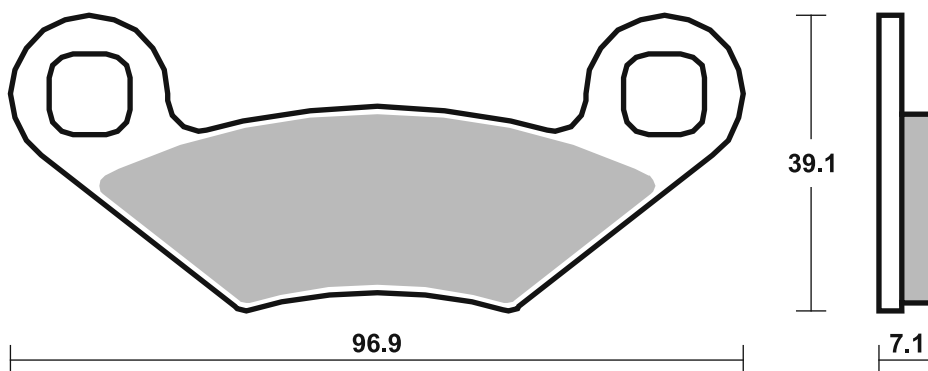

## Applications

### SBS 643 Recommended compound



<b>POLARIS</b>			
250 Cyclone	87 - 87		<b>HF</b>
250 Trail Boss	88 - 90		<b>HF</b>

### SBS 644 Recommended compound



<b>BMW</b>			
R80	800 R	91 - 95	<b>HS</b>
K1	1000	89 - 89	<b>HS</b>
K100	1000 LT	92 - 94	<b>HS</b>
K100	1000 RS	90 - 92	<b>HS</b>
R100	1000 R	91 - 95	<b>HS</b>
K1100	1100 LT/SE	92 - 00	<b>HS</b>
K1100	1100 RS	93 - 96	<b>HS</b>
R1100	1100 RS	93 - 93	<b>HS</b>

### SBS 645 Recommended compound



<b>YAMAHA</b>			
FZR	500 R (Austria)	90 - 91	<b>HS</b>
FZR	600 R	90 - 91	<b>HS</b>
TDM	850	96 - 01	<b>HS</b>
FZR	1000 EX UP	90 - 91	<b>HS</b>
V-MAX	1200	93 - 03	<b>HS</b>

Brake Pad 1:1 Drawings,  
Compounds, Fitments

STREET  
AMERICAN  
SCOOTER

HF • HS • LS  
H.HF • H.CT • H.HS • H.LS  
HF • CT • MS

RACING  
OFF ROAD  
ATV

RST • DC • DCC • DS-1 • DS-2 • RQ  
SI • RSI • CS  
ATS • SI • RSI • PSI

Available compounds

HF

SBS 643

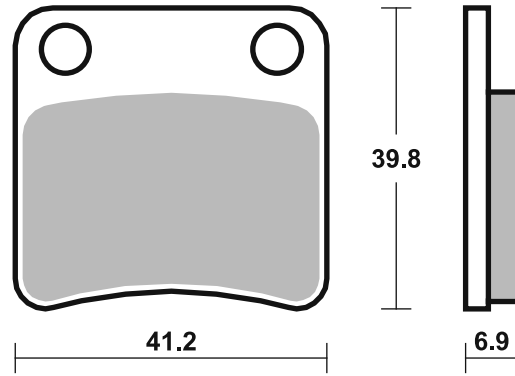

Available compounds

HF • HS

SBS 644

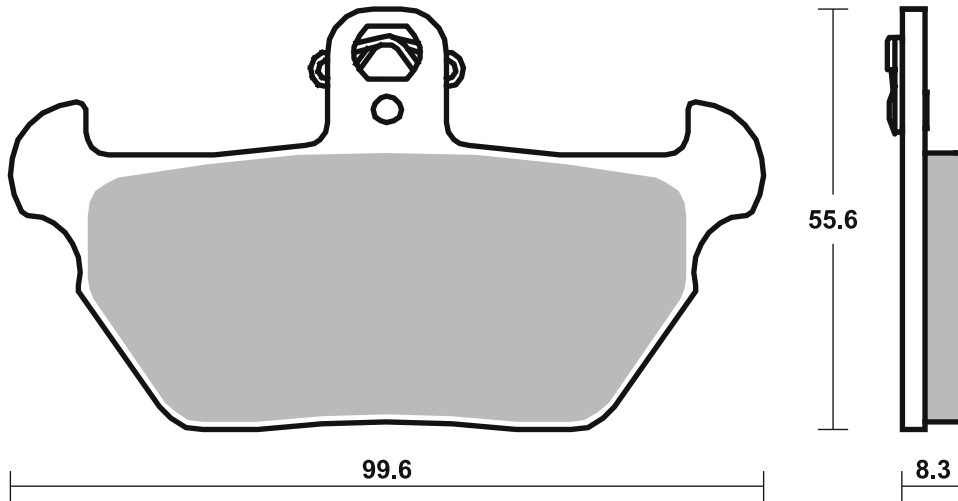

Available compounds

HF • HS • DCC

SBS 645

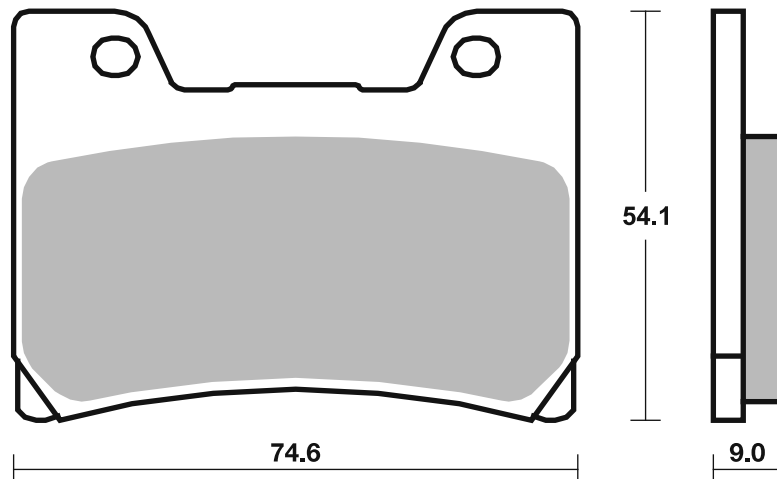





STREET  
AMERICAN  
SCOOTER

HF • HS • LS  
H.HF • H.CT • H.HS • H.LS  
HF • CT • MS

RACING  
OFF ROAD  
ATV

RST • DC • DCC • DS-1 • DS-2 • RQ  
SI • RSI • CS  
ATS • SI • RSI • PSI

Available compounds

HF

SBS 646

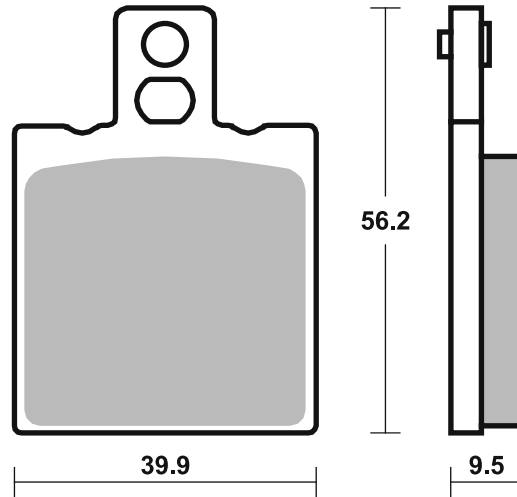

Available compounds

HF • HS

SBS 647

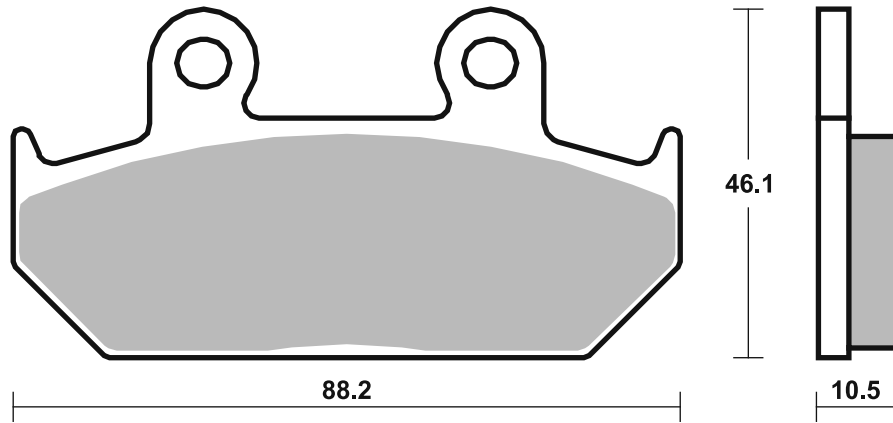

Available compounds

HF • SI • RSI

SBS 648

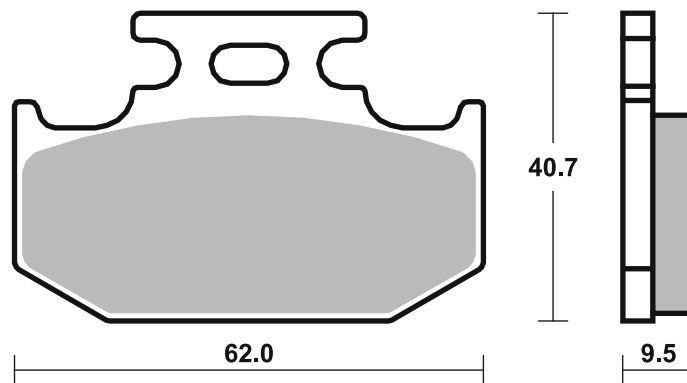

Brake Pad 1:1 Drawings,  
Compounds, Fitments

## Applications

### SBS 649

### Recommended compound



#### ARCTIC CAT

	400 DVX	04 - 08	<b>SI</b>
--	---------	---------	-----------

#### HYOSUNG

TE	400	05 - 06	<b>SI</b>
----	-----	---------	-----------

TE	450	07 - 11	<b>SI</b>
----	-----	---------	-----------

#### KAWASAKI

KFX	400	02 - 05	<b>SI</b>
-----	-----	---------	-----------

#### SUZUKI

LT	250	88 - 94	<b>SI</b>
----	-----	---------	-----------

LT-Z	400 Quad Sport	02 - 19	<b>SI</b>
------	----------------	---------	-----------

LT-R	450	06 - 12	<b>SI</b>
------	-----	---------	-----------

LT	500	87 - 95	<b>SI</b>
----	-----	---------	-----------

### SBS 650

### Recommended compound



#### YAMAHA

	400 Artesia	91 - 92	<b>HS</b>
--	-------------	---------	-----------

XT	500 E (Austria)	90 - 96	<b>HS</b>
----	-----------------	---------	-----------

XT	600 E	90 - 03	<b>HS</b>
----	-------	---------	-----------

XT	600 K	91 - 94	<b>HS</b>
----	-------	---------	-----------

XTZ	660 Tenere	91 - 98	<b>HS</b>
-----	------------	---------	-----------

STREET  
AMERICAN  
SCOOTER

HF • HS • LS  
H.HF • H.CT • H.HS • H.LS  
HF • CT • MS

RACING  
OFF ROAD  
ATV

RST • DC • DCC • DS-1 • DS-2 • RQ  
SI • RSI • CS  
ATS • SI • RSI • PSI

Drawings 1:1

Available compounds

HF • SI • RSI

SBS 649

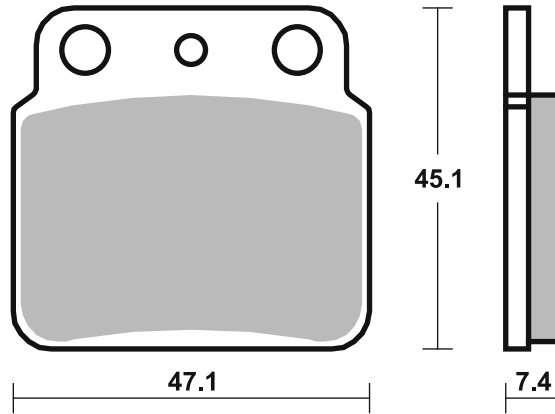

Available compounds

HF • HS

SBS 650

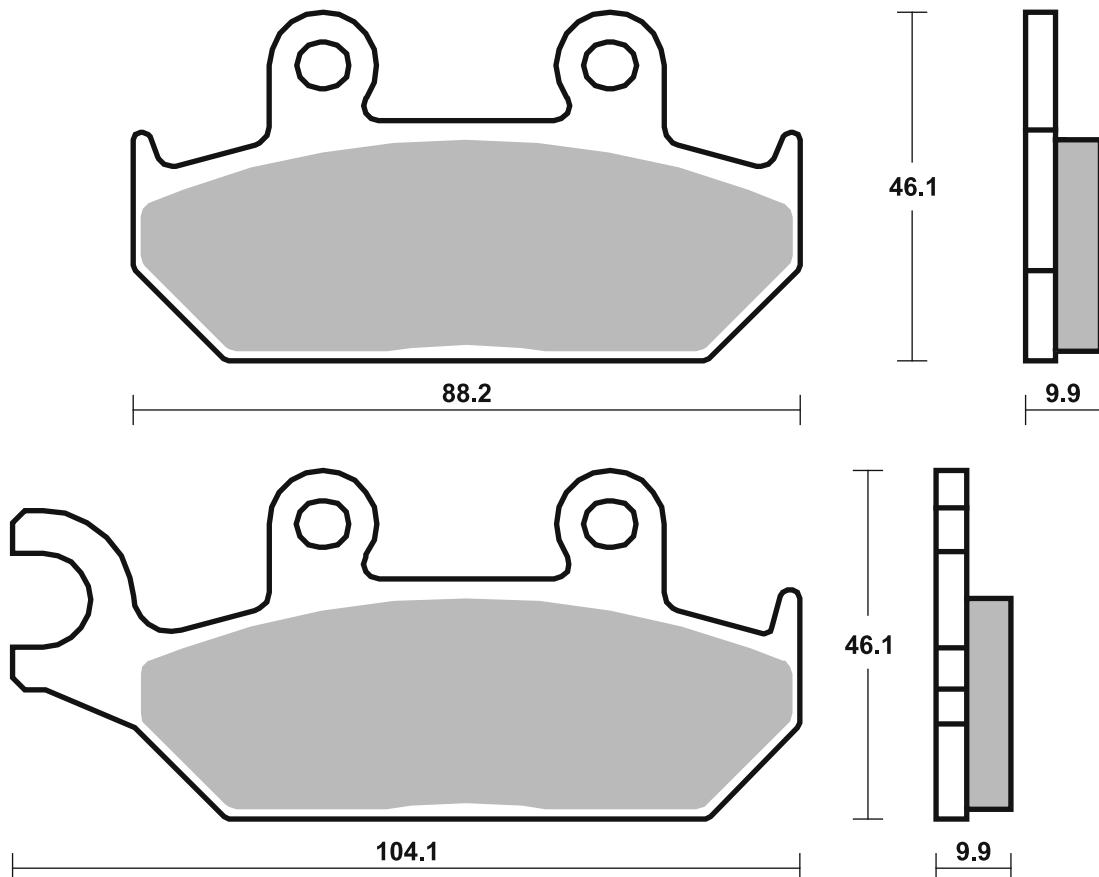

Dimensions in mm / Dimensions en mm  
1" = 25.4 mm, 1 mm = 0.04"

Brake Pad 1:1 Drawings,  
Compounds, Fitments

## Applications

### SBS 651 Recommended compound



<b>APRILIA</b>			
	125 Pegaso	92 - 99	<b>HF</b>
	125 Tuareg Rally	86 - 92	<b>HF</b>
<b>MX</b>	125	04 - 07	<b>HF</b>
<b>MX</b>	125 Supermoto	07 - 07	<b>HF</b>
<b>SX</b>	125	08 - 13	<b>HF</b>
	600 Pegaso	90 - 92	<b>HF</b>
	650 Pegaso	92 - 94	<b>HF</b>

<b>CAGIVA</b>			
<b>WMX</b>	50	89 - 89	<b>HF</b>

### SBS 652 Recommended compound



<b>APRILIA</b>			
	125 Classic	96 - 03	<b>HF</b>
	125 Pegaso	90 - 91	<b>HF</b>
	125 Red Rose	90 - 97	<b>HF</b>
	125 Tuareg Rally	86 - 92	<b>HF</b>
	125 Tuareg Wind	90 - 94	<b>HF</b>

<b>HRD</b>			
	50 GS Enduro	00 - 02	<b>HF</b>
	125 Supermotard	00 - 02	<b>HF</b>
	125 Trail	00 - 02	<b>HF</b>

<b>ITALJET</b>			
<b>SM</b>	125	02 - 05	<b>HF</b>

<b>RIEJU</b>			
<b>MRX</b>	125	03 - 08	<b>HF</b>
<b>SMX</b>	125	03 - 07	<b>HF</b>

<b>SIMSON</b>			
	125 SM	01 - 01	<b>HF</b>

STREET  
AMERICAN  
SCOOTER

HF • HS • LS  
H.HF • H.CT • H.HS • H.LS  
HF • CT • MS

RACING  
OFF ROAD  
ATV

RST • DC • DCC • DS-1 • DS-2 • RQ  
SI • RSI • CS  
ATS • SI • RSI • PSI

Available compounds

HF

SBS 651

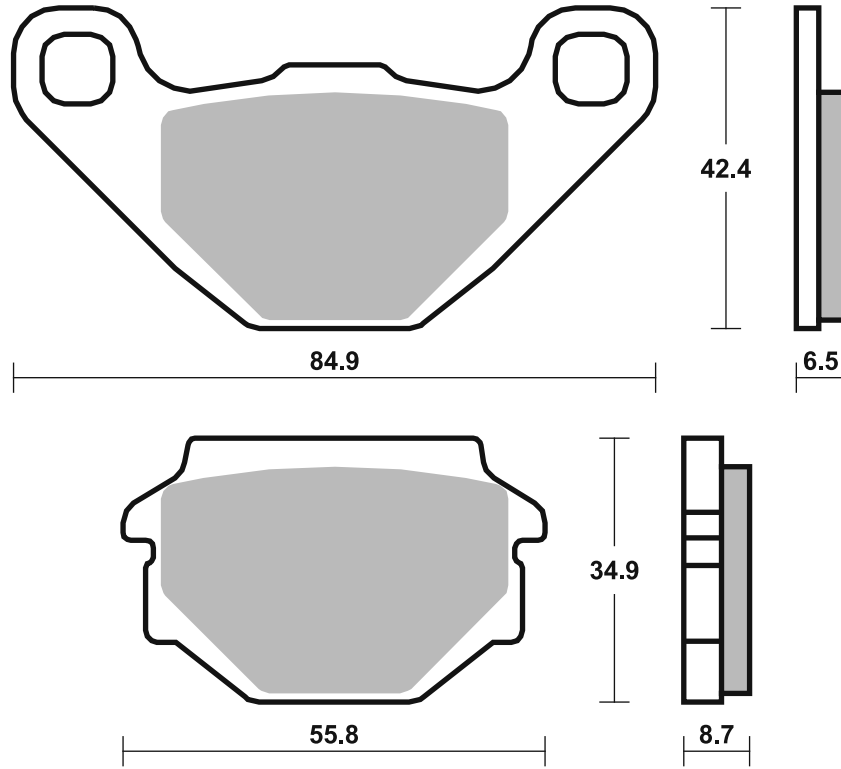

Available compounds

HF

SBS 652

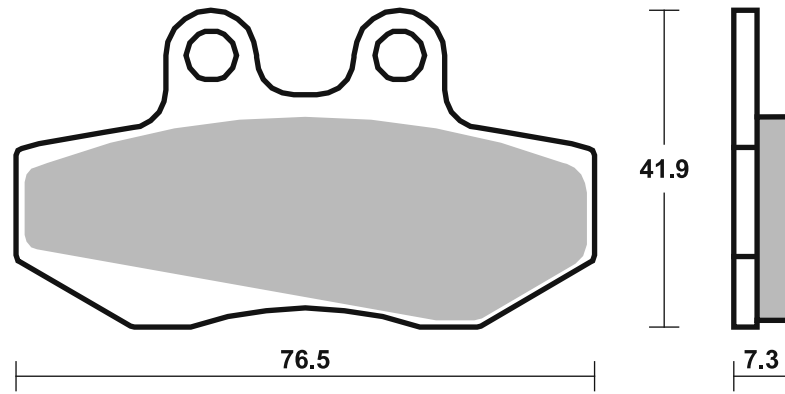

## Applications

### SBS 653 Recommended compound



#### YAMAHA

DT	125 Tenere Scout	90 - 94	HF
DTZ	125 Tenere	90 - 94	HF

### SBS 654 Recommended compound



#### HONDA

VTR	250	98 - 02	HF
CB	400 Super Four	92 - 95	HS
NTV	650	94 - 97	HS
ST	1100	90 - 02	LS
ST	1100 ABS-TCS	92 - 95	LS

#### YAMAHA

MT-01	1700	05 - 16	LS
-------	------	---------	----

STREET  
AMERICAN  
SCOOTER

HF • HS • LS  
H.HF • H.CT • H.HS • H.LS  
HF • CT • MS

RACING  
OFF ROAD  
ATV

RST • DC • DCC • DS-1 • DS-2 • RQ  
SI • RSI • CS  
ATS • SI • RSI • PSI

Drawings 1:1

Available compounds

HF

SBS 653

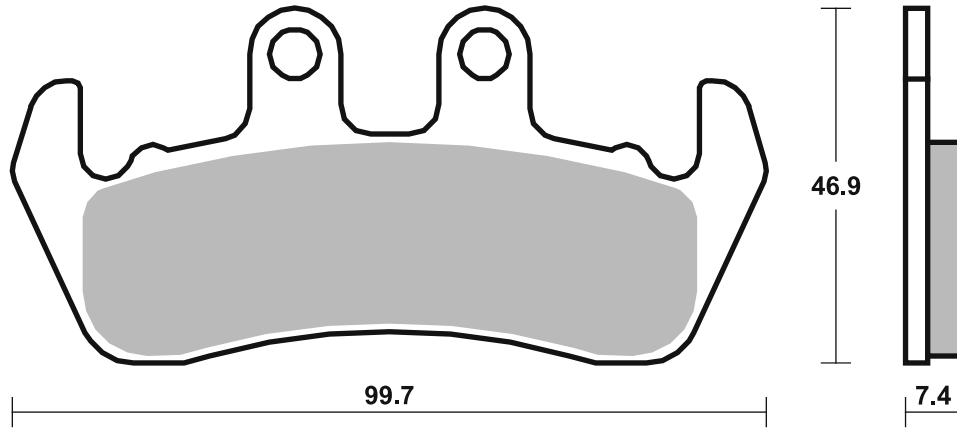

Available compounds

HF • HS • LS

SBS 654

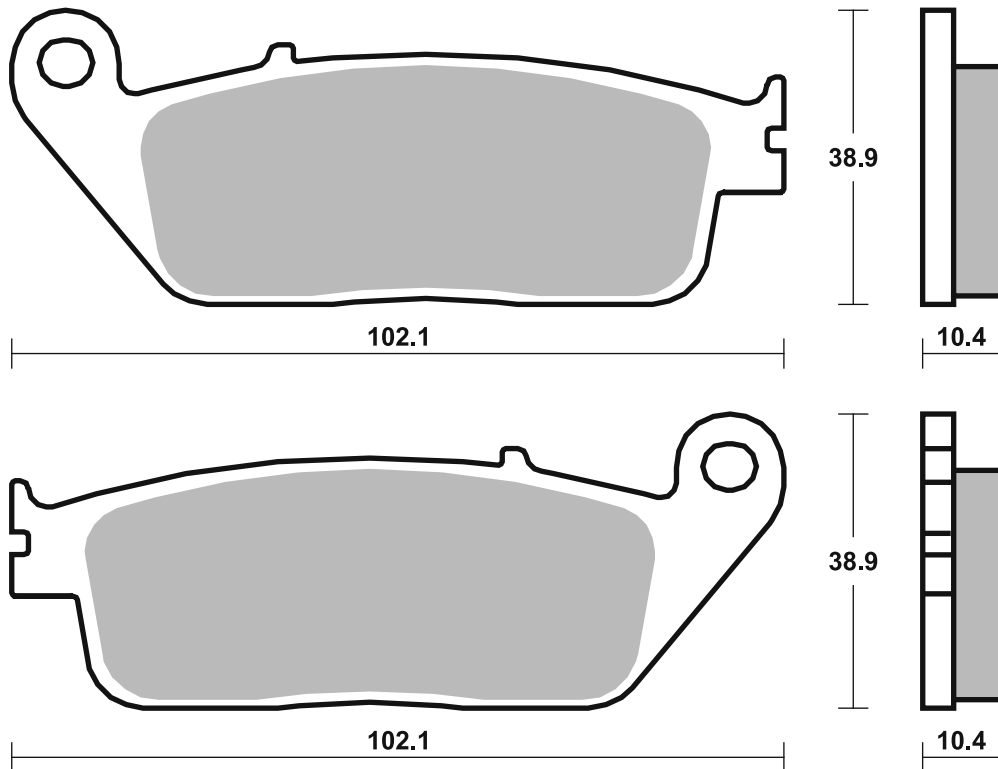

# Applications

## SBS 655

### Recommended compound



#### ISR CALIPERS

2 Piston (22-036)

4 Piston (22-043)

6 Piston Racing Caliper, small

## SBS 656

### Recommended compound



#### HARRISON/BILLET CALIPERS

Mini-6

#### ISR CALIPERS

6 Piston Racing Caliper, large



STREET  
AMERICAN  
SCOOTER

HF • HS • LS  
H.HF • H.CT • H.HS • H.LS  
HF • CT • MS

RACING  
OFF ROAD  
ATV

RST • DC • DCC • DS-1 • DS-2 • RQ  
SI • RSI • CS  
ATS • SI • RSI • PSI

Drawings 1:1

Available compounds

HF • DC

SBS 655

1 set = 6 pcs.

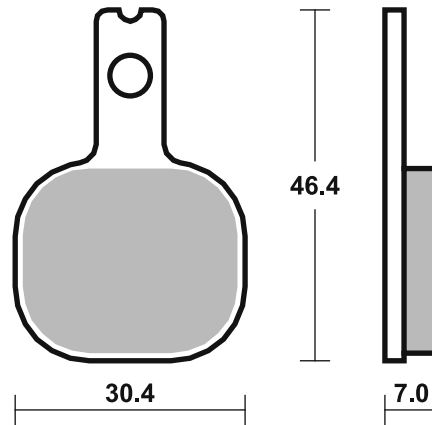

Available compounds

HF • DC • RQ • H.HF

SBS 656

1 set = 6 pcs.

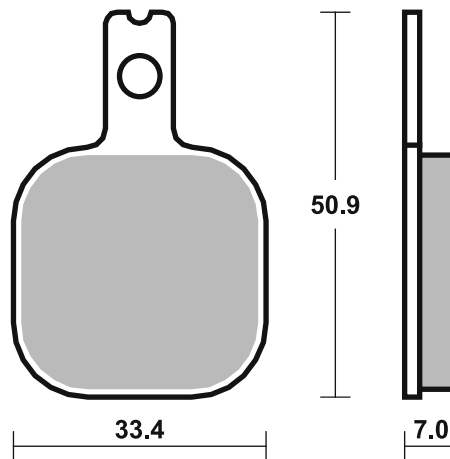



<b>HONDA</b>			
CBR	400 F	92 -96	LS
CBF	500	04 -08	LS
CBF	500 ABS	04 -08	LS
CB	600 Hornet	98 -06	LS
CB	600 Hornet (Japan)	98 -99	LS
CB	600 Hornet ABS	07 -12	LS
CB	600 Hornet, S	00 -03	LS
CBF	600 N	04 -11	LS
CBF	600 N ABS	08 -11	LS
CBF	600 S	04 -11	LS
CBF	600 S ABS	08 -11	LS
CBR	600 F ABS	11 -13	LS
CBR	600 F, Super Sport	91 -94	LS
CBR	600 F3	95 -98	LS
CBR	600 F4, F4 Sport	99 -06	LS
CBR	600 RR	03 -06	LS
NT	650 V Deauville	01 -01	LS
NC	700 D Integra	12 -13	LS
NC	700 SA ABS	12 -13	LS
NC	700 SD ABS	12 -13	LS
NC	700 XA ABS	12 -13	LS
NC	700 XD ABS	12 -13	LS
XL	700 Transalp ABS	08 -12	LS
CB	750 N, F, Seven Fifty	92 -95	LS
NR	750	92 -92	LS
XL	750 Transalp	23 -24	LS
CB	900 Hornet	02 -07	LS
CBR	900 RR Fireblade	92 -03	LS
CB	1000 F (Big One)	93 -97	LS
CBF	1000	06 -11	LS
CBF	1000 F ABS	15 -18	LS
CBF	1000 Limited Edition	09 -14	LS
CBR	1000 RR Fireblade	04 -05	LS
CRF	1000 L Africa Twin	16 -19	LS
CRF	1000 L Africa Twin Adventure Sports	18 -19	LS
VTR	1000 F Firestorm	97 -07	LS
VTR	1000 SP-1, SP-2	00 -06	LS
CB	1100	13 -13	LS
CB	1100	14 -21	LS
CB	1100 EX	14 -21	LS
CB	1100 RS ABS	17 -21	LS
CRF	1100 L Africa Twin	20 -24	LS
CRF	1100 L Africa Twin Adventure Sports	20 -24	LS
NT	1100	22 -24	LS
VT	1100 C2 Shadow A.C.E.	95 -04	LS
VT	1100 C2 Y	00 -05	LS
VT	1100 C3 Shadow Aero	98 -04	LS
VT	1100 T Shadow	98 -04	LS
CB	1300	05 -13	LS
CB	1300 S	11 -15	LS
VT	1300 CX A Fury	10 -22	LS
VTX	1300 C	04 -09	LS
VTX	1300 S	03 -07	LS
<b>KAWASAKI</b>			
ZX-25R	250	20 -23	LS
ZX-4R	400	23 -24	LS
ZX-4R	400 SE	23 -24	LS
ZX-4RR	400	23 -24	LS
EN	650 Vulcan S	15 -24	LS
EN	650 Vulcan S Cafe	17 -19	LS
EN	650 Vulcan S SE	17 -18	LS
EX	650 Ninja ABS	17 -23	LS
EX	650 Ninja Performance ABS	17 -23	LS
EX	650 Ninja Tourer ABS	17 -23	LS
KLE	650 Versys	16 -24	LS



<b>KAWASAKI</b>			
KLE	650 Versys ABS	16 -23	LS
Z	650 ABS	17 -24	LS
Z	650 RS	22 -24	LS
Z	750 , ABS	07 -12	LS
Z	900 RS	18 -24	LS
Z	900 RS Cafe	18 -21	LS
Z	900 RS SE	22 -24	LS
KLE	1000 Versys	12 -24	LS
KLE	1000 Versys ABS	15 -24	LS
KLE	1000 Versys LT	15 -16	LS
KLE	1000 Versys S	21 -24	LS
KLE	1000 Versys SE	19 -24	LS
KLV	1000	04 -07	LS
Z	1000	07 -09	LS
Z	1000 H2	20 -23	LS
Z	1000 H2 SE	21 -24	LS
<b>MBP</b>			
C	650 V	23 -23	LS
<b>SUZUKI</b>			
DL	250 V-Strom	17 -23	HF
GW	250 Inazuma	12 -19	LS
DL	650 V-Strom	04 -24	LS
DL	650 V-Strom XT	15 -24	LS
GSF	650 Bandit	07 -11	LS
GSF	650 Bandit / S Bandit ABS	06 -06	LS
GSF	650 Bandit ABS	07 -12	LS
GSF	650 S Bandit	07 -11	LS
GSF	650 S Bandit ABS	07 -13	LS
GSX	650 F	08 -18	HF
SV	650 S	03 -12	LS
SV	650 S ABS	07 -18	LS
GSR	750	11 -16	LS
GSX-S	750	15 -20	LS
GSX-S	750 Z	15 -16	LS
DL	800 V-Strom DE	23 -24	LS
DL	800 V-Strom SE	24 -24	LS
GSX-8R	800	24 -24	LS
GSX-8S	800	23 -24	LS
GSX-S	950	22 -24	LS
DL	1000 V-Strom	02 -13	LS
GSX-S	1000	15 -24	LS
GSX-S	1000 F	15 -23	LS
GSX-S	1000 GT	22 -24	LS
GSX-S	1000 GX	24 -24	LS
GSX-S	1000 Katana	19 -24	LS
SV	1000 , S	03 -07	LS
GSF	1200 Bandit	06 -06	LS
GSF	1200 S Bandit	06 -06	LS
GSF	1250 A Bandit	07 -18	LS
GSF	1250 Bandit	06 -18	LS
GSF	1250 F Bandit	12 -18	LS
GSF	1250 S Bandit	06 -18	LS
GSF	1250 SA Bandit	07 -18	LS
GSX	1250 FA Bandit	16 -18	LS
GSX	1250 FA Traveller	15 -16	LS
	1300 B-King	07 -07	LS
<b>VOGUE</b>			
	500 R	23 -23	LS
AC	500	23 -23	LS
ACX	500	23 -23	LS
DS	500	23 -23	LS
DSX	500	23 -23	LS
	525 Brivido R	24 -24	LS
	525 Brivido RR	24 -24	LS
	525 Trofeo ACX	24 -24	LS
	525 Valico DSX	24 -24	LS



<b>VOGUE</b>			
DSX	650	23 -23	LS
<b>YAMAHA</b>			
FZ6	600	04 -08	LS
FZ6	600 Fazer	04 -08	LS
FZ6	600 Fazer S2	07 -09	LS
FZ6	600 Fazer S2 ABS	07 -09	LS
FZ6	600 S2	07 -09	LS
FZ6	600 S2 ABS	07 -09	LS
XJ6-F	600	13 -15	LS
XJ6-N	600	13 -15	LS
XJ6-S	600	13 -15	LS
YZF	600 R6	03 -16	LS
	700 Tracer 7	21 -24	LS
	700 Tracer 7 GT	21 -24	LS
MT-07	700	14 -24	LS
MT-07	700 Moto Cage	15 -17	LS
MT-07	700 SP	18 -18	LS
MT-07	700 Tracer	16 -20	LS
MT-07	700 Tracer GT	19 -19	LS
XSR	700	16 -24	LS
XSR	700 XTribute	19 -22	LS
YZF	700 R7	22 -24	LS
	800 Fazer 8	10 -15	LS
FZ8	800	10 -14	LS
	900 Tracer 9	15 -24	LS
	900 Tracer 9 GT	18 -24	LS
MT-09	900	14 -24	LS
MT-09	900 SP	18 -24	LS
MT-09	900 Sport Tracker	15 -16	LS
MT-09	900 Street Rally	14 -16	LS
XSR	900	16 -24	LS
XSR	900 Abarth	17 -22	LS
XSR	900 GP	24 -24	LS
FZ1	1000 Fazer	06 -16	LS
MT-10	1000	16 -24	LS
MT-10	1000 SP	17 -24	LS
MT-10	1000 Tourer Ed.	17 -19	LS
YZF	1000 R1	04 -06	LS
YZF	1000 R1 (4-pad)	07 -14	LS
YZF	1000 R1 (4-pad) ABS	12 -14	LS
YZF	1000 R1 SP	06 -06	LS

STREET  
AMERICAN  
SCOOTER

HF • HS • LS  
H.HF • H.CT • H.HS • H.LS  
HF • CT • MS

RACING  
OFF ROAD  
ATV

RST • DC • DCC • DS-1 • DS-2 • RQ  
SI • RSI • CS  
ATS • SI • RSI • PSI

Available compounds

HF • LS • RQ

SBS 657

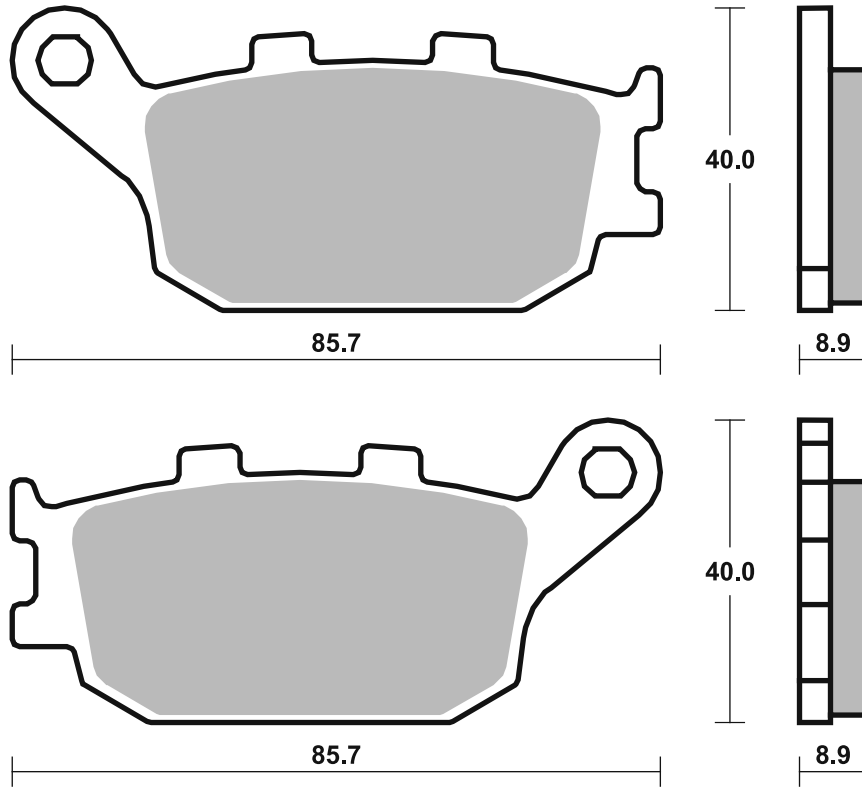

## Applications

### SBS 658

Recommended compound



<b>BUELL</b>			
	all models	94 - 97	<b>HF</b>
RS	1200	12 - 12	<b>HF</b>
<b>PERFORMANCE MACHINE</b>			
	125 X 6		
	137 X 6		

### SBS 659

Recommended compound



<b>YAMAHA</b>			
TZ	125	97 - 00	<b>RQ</b>
TZ	250	90 - 05	<b>RQ</b>
TZR	250 R	94 - 94	<b>HF</b>

### SBS 660

Recommended compound



<b>A.P. RACING CALIPERS</b>			
6 Piston 3366/3367 Series			

Brake Pad 1:1 Drawings,  
Compounds, Fitments

STREET  
AMERICAN  
SCOOTER

HF • HS • LS  
H.HF • H.CT • H.HS • H.LS  
HF • CT • MS

RACING  
OFF ROAD  
ATV

RST • DC • DCC • DS-1 • DS-2 • RQ  
SI • RSI • CS  
ATS • SI • RSI • PSI

Drawings 1:1

Available compounds

HF • RQ • H.HF • H.CT

SBS 658

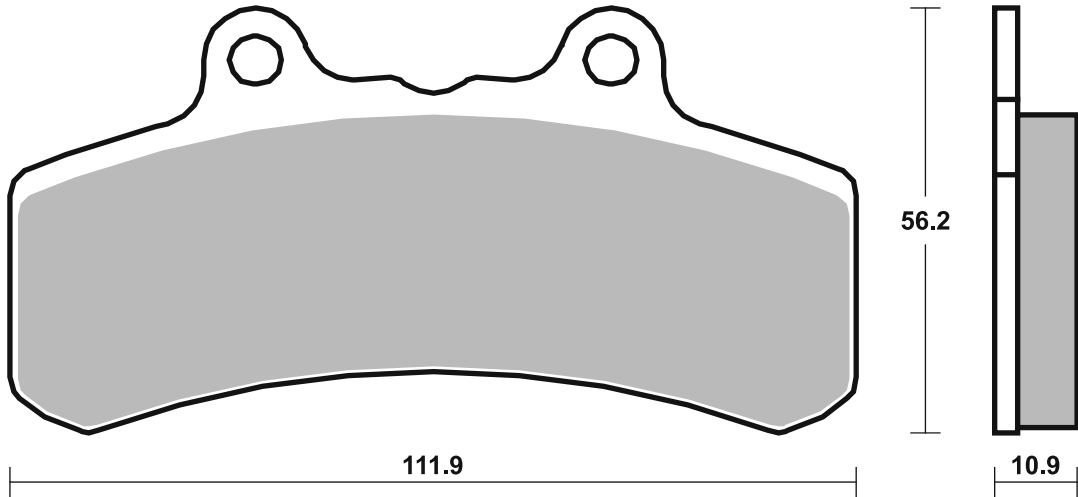

Available compounds

HF • RQ

SBS 659

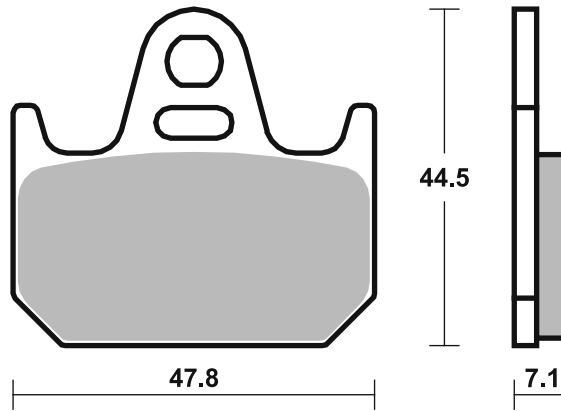

Available compounds

RQ

SBS 660

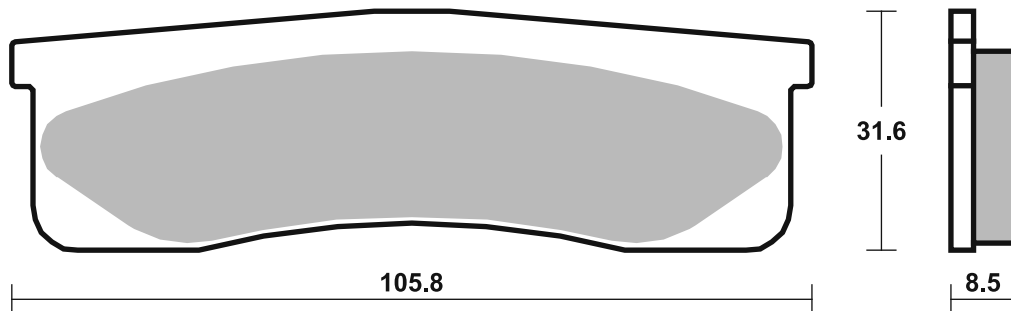

**Applications**

**SBS 661**

**Recommended compound**



**A.P. RACING CALIPERS**

CP-3485-8S0/9S0	
CP-3569-4S0/5S0	
CP-3586-4S0/5S0	

**SBS 662**

**Recommended compound**



**PERFORMANCE MACHINE**

124 X 4HR	
137 X 4	

**SBS 663**

**Recommended compound**



<b>SYM</b>			
NH	125 T	19 - 19	<b>HF</b>
NH	125 X	19 - 19	<b>HF</b>
<b>YAMAHA</b>			
FZX	250 Zeal	91 - 92	<b>HS</b>
SRV	250	92 - 97	<b>HS</b>
SR	400	14 - 16	<b>HS</b>
XJ	400 Diversion	91 - 93	<b>HS</b>
XV	535 DX Virago	98 - 03	<b>HS</b>
XV	535 S Virago	96 - 03	<b>HS</b>
XV	535 Virago	95 - 97	<b>HS</b>
XJ	600 N	91 - 97	<b>HS</b>
XJ	600 S Diversion	91 - 97	<b>HS</b>
XVS	650 A Drag Star		
	Classic	98 - 06	<b>HS</b>
XVS	650 Drag Star	97 - 06	<b>HS</b>
XJ	900 S, Diversion	94 - 03	<b>HS</b>
SCR	950 Scrambler	17 - 19	<b>HS</b>



<b>YAMAHA</b>			
XV	950 Bolt	14 - 18	<b>HS</b>
XV	950 Bolt C-Spec	15 - 18	<b>HS</b>
XV	950 Bolt Racer	17 - 18	<b>HS</b>
XV	950 Bolt R-Spec	14 - 22	<b>HS</b>
XV	950 R	19 - 20	<b>HS</b>
XVS	950 A Midnight Star	09 - 13	<b>HS</b>
XV	1100 Virago	94 - 98	<b>HS</b>
XVS	1300 Stryker	11 - 14	<b>HS</b>
XVZ	1300 TF Royal Star		
	Venture	99 - 01	<b>HS</b>
XV	1600 A Wild Star	99 - 07	<b>HS</b>

STREET  
AMERICAN  
SCOOTER

HF • HS • LS  
H.HF • H.CT • H.HS • H.LS  
HF • CT • MS

RACING  
OFF ROAD  
ATV

RST • DC • DCC • DS-1 • DS-2 • RQ  
SI • RSI • CS  
ATS • SI • RSI • PSI

Available compounds

RQ

SBS 661

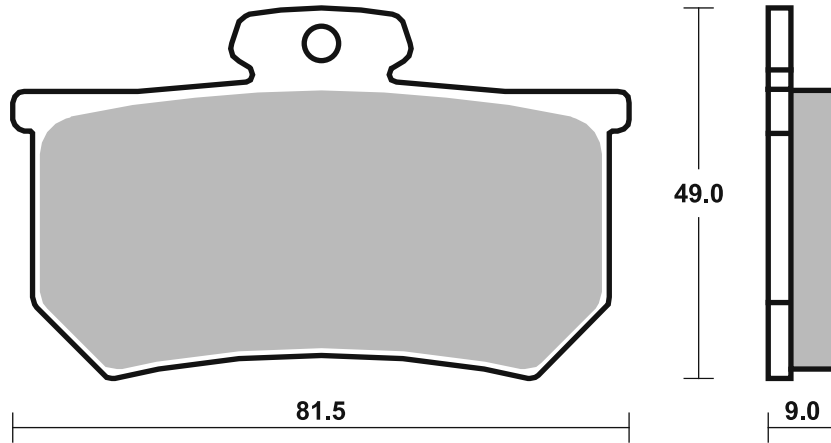

Available compounds

HF • RQ • H.HF • H.CT

SBS 662

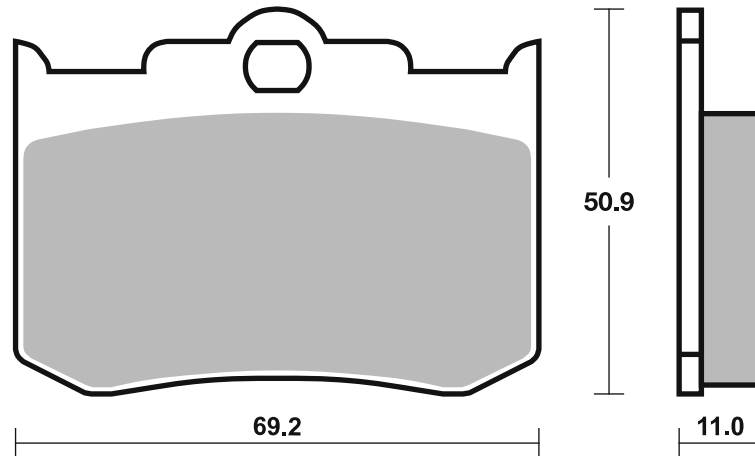

Available compounds

HF • HS

SBS 663

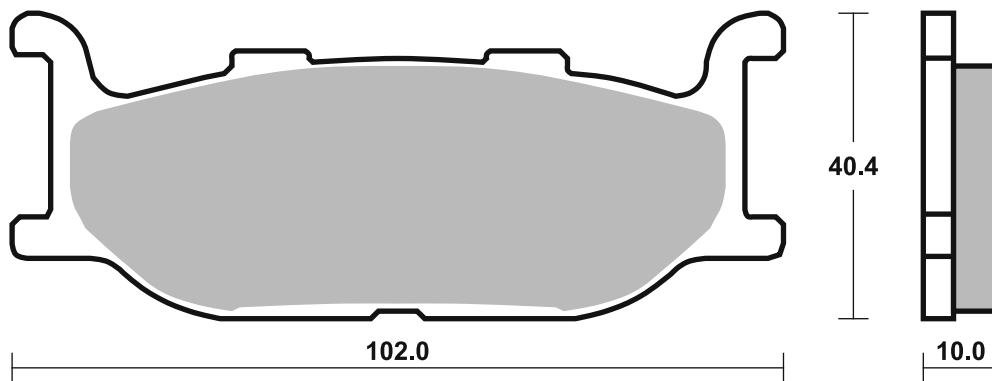

## Applications

### SBS 664

### Recommended compound



<b>HONDA</b>			
TLM	220	89 - 91	HF
TLM	260 R	90 - 90	HF

### SBS 665

### Recommended compound



<b>YAMAHA</b>			
FZR	600 R	92 - 95	HS
FZR	1000 EX UP	92 - 93	HS

### SBS 666

### Recommended compound



<b>KAWASAKI</b>			
ZXR	400	91 - 02	HS

Brake Pad 1:1 Drawings,  
 Compounds, Fitments



STREET  
AMERICAN  
SCOOTER

HF • HS • LS  
H.HF • H.CT • H.HS • H.LS  
HF • CT • MS

RACING  
OFF ROAD  
ATV

RST • DC • DCC • DS-1 • DS-2 • RQ  
SI • RSI • CS  
ATS • SI • RSI • PSI

Drawings 1:1

Available compounds

HF

SBS 664

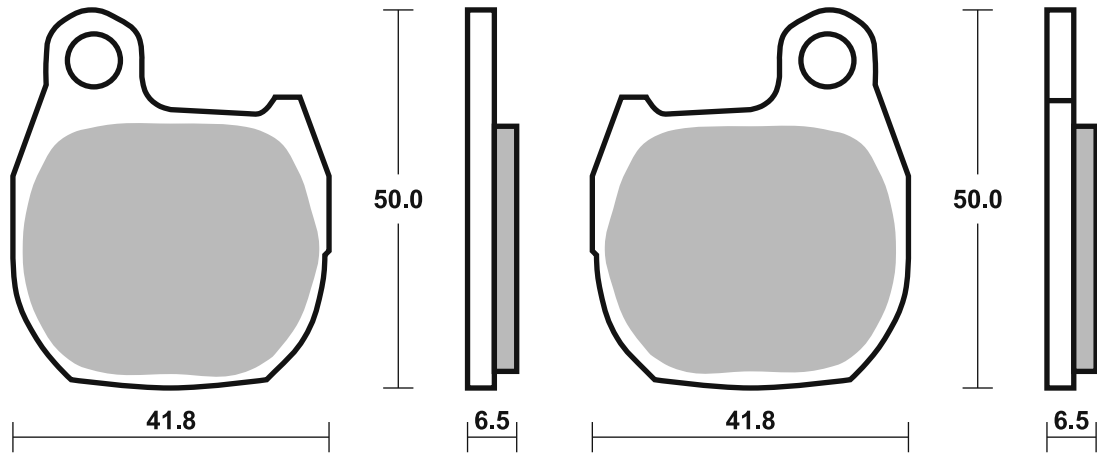

Available compounds

HF • HS

SBS 665

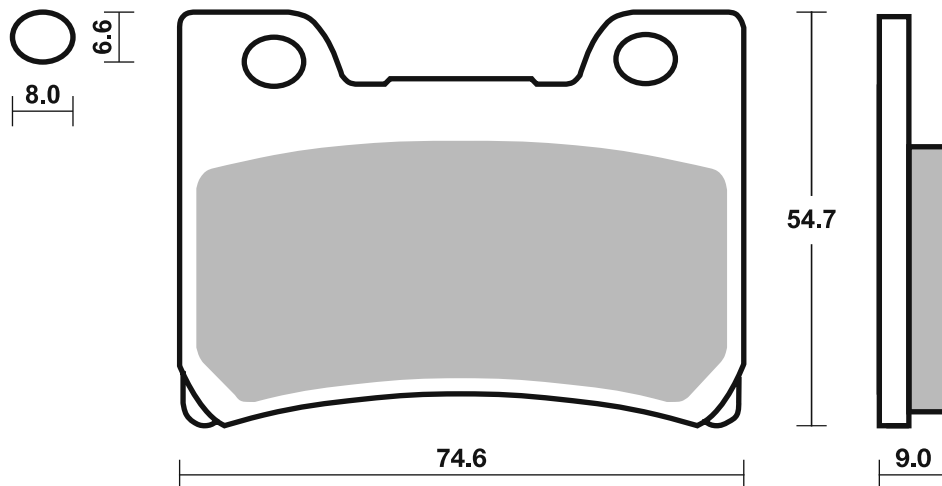

Available compounds

HF • HS • RST

SBS 666

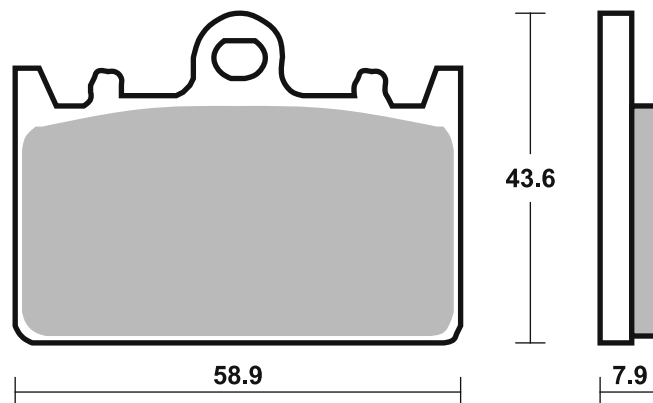



STREET  
AMERICAN  
SCOOTER

HF • HS • LS  
H.HF • H.CT • H.HS • H.LS  
HF • CT • MS

RACING  
OFF ROAD  
ATV

RST • DC • DCC • DS-1 • DS-2 • RQ  
SI • RSI • CS  
ATS • SI • RSI • PSI

Drawings 1:1

Available compounds

HF

SBS 667

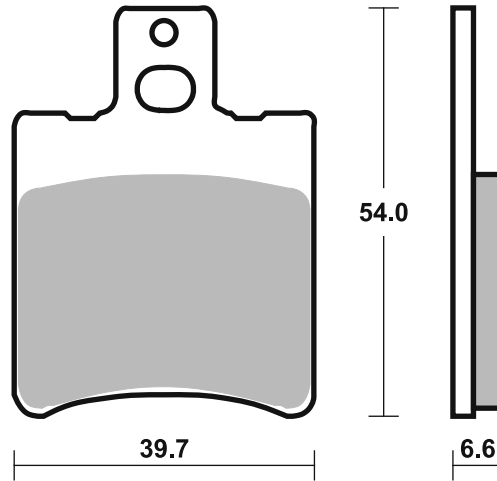

Available compounds

H.HF • H.CT • H.LS

SBS 668

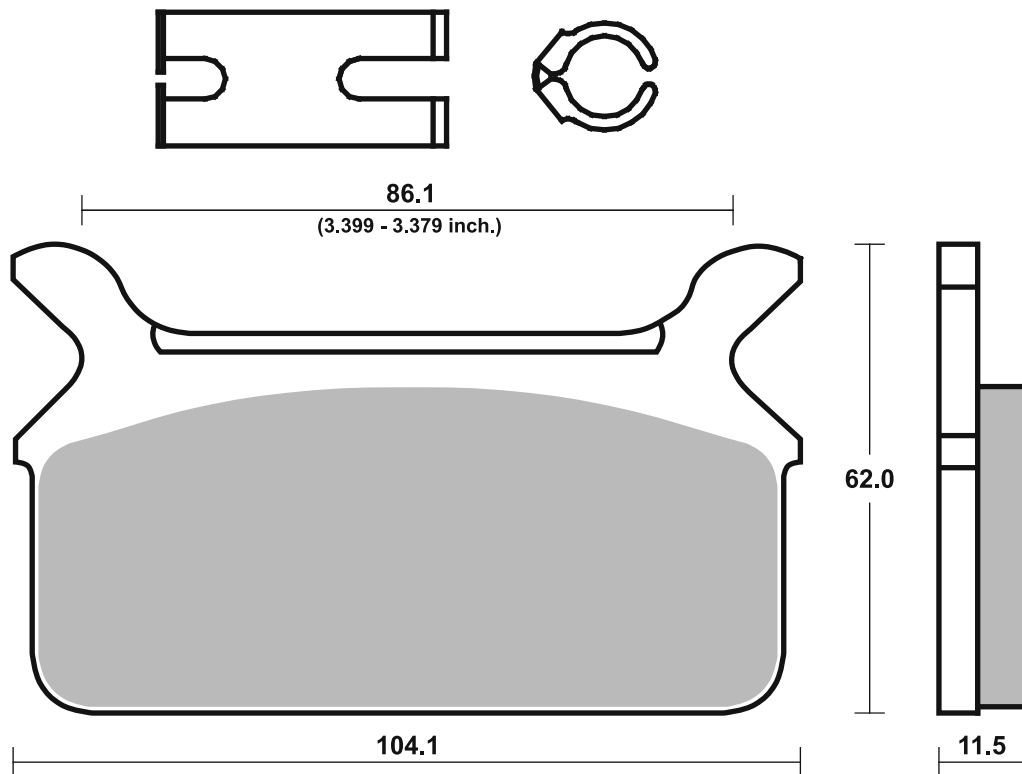



STREET  
AMERICAN  
SCOOTER

HF • HS • LS  
H.HF • H.CT • H.HS • H.LS  
HF • CT • MS

RACING  
OFF ROAD  
ATV

RST • DC • DCC • DS-1 • DS-2 • RQ  
SI • RSI • CS  
ATS • SI • RSI • PSI

Drawings 1:1

Available compounds

H.HF • H.CT • H.LS

SBS 669

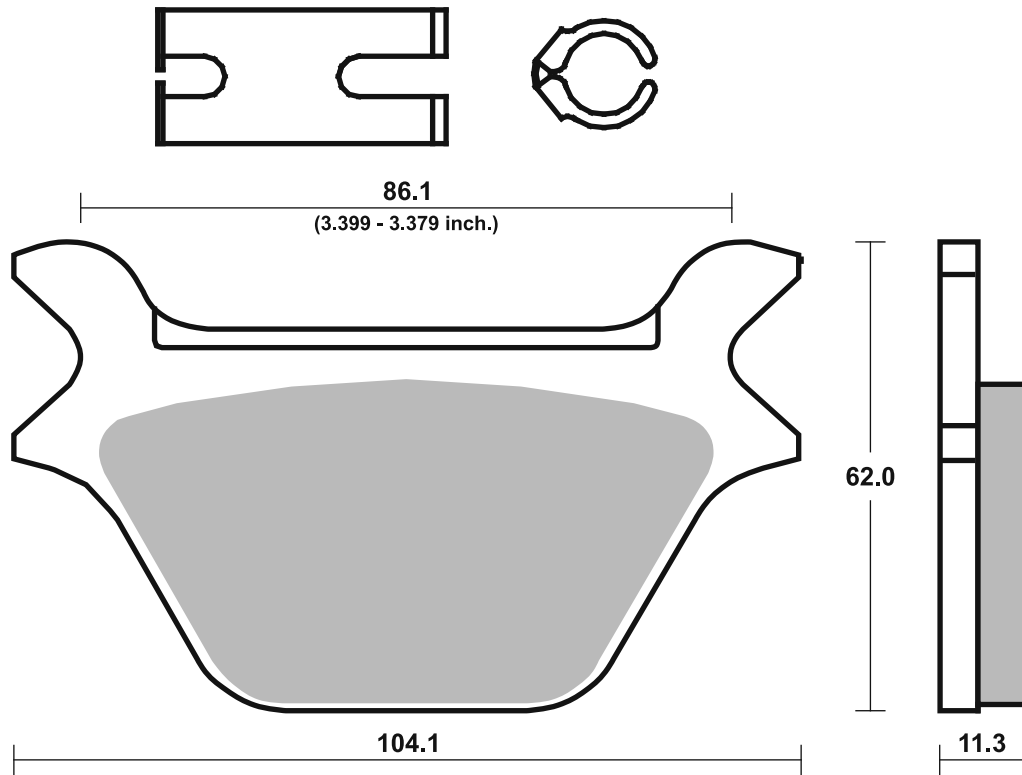

Available compounds

HF

SBS 670

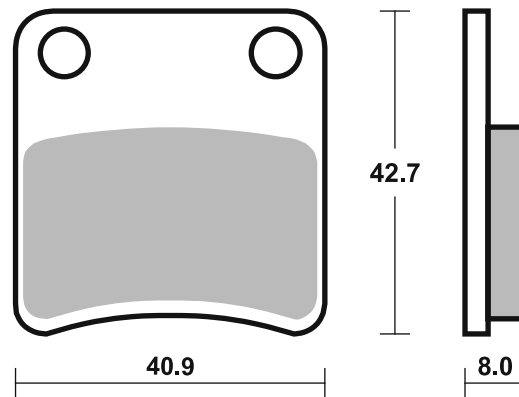



ALFER			
VRE	125 4-stroke	00 -00	SI
VR	250 Cross	99 -99	RSI
VR	250 Enduro	99 -99	SI
VR	250 No Limit	99 -99	RSI
VR	250 Supermotard	99 -99	RSI

APRILIA			
MX	125	04 -07	HF
MX	125 Supermoto	07 -07	HF
RX	125	97 -99	HF
RX	125 Enduro	08 -12	HF
RX	125 Supermotard	08 -12	HF
SX	125	08 -13	HF
RST	1000 Futura	01 -03	LS

BENELLI			
BX	449 Cross	07 -09	RSI
BX	505 Enduro	08 -08	SI

BIMOTA			
DBX	1100	13 -18	LS

BMW			
G	450 X	08 -10	SI
	1200 HP2 Enduro	04 -06	LS
	1200 HP2 Sport	08 -10	LS
K	1200 GT (K44) With Integral ABS	04 -08	LS
R	1200 NineT	14 -23	LS
R	1200 NineT Pure	17 -23	LS
R	1200 NineT Racer	17 -20	LS
R	1200 NineT Scrambler	16 -23	LS
R	1200 NineT Urban GS	17 -23	LS
R12	1200	24 -24	LS
R12	1200 NineT	24 -24	LS
K	1300 GT	09 -10	LS

#### BREMBO RACING CALIPERS

Floating Motocross Caliper			
22.5930.62			
Off Road 122A99021, P2 24			
Off Road XQ21361, P2 28			

CAGIVA			
	750 Elefant	93 -95	LS
	900 Elefant	93 -97	HF HF

CCM			
	450 MX	08 -10	RSI
GP	450	16 -16	SI
604	600 RS	01 -01	HF
604E	600 Sport	99 -01	SI
604E	600 Supermoto	99 -01	SI
C25	600	96 -98	SI
	644 DS	03 -06	HF
	644 R30	02 -06	HF

CF MOTO			
	AE8	22 -23	HS
	700 CL-X Adventure	24 -24	LS
	700 CL-X Heritage	22 -22	LS
	800 MT Explore	24 -24	LS
	800 MT Sport	22 -22	LS
	800 MT Touring	22 -22	LS
	800 NK	24 -24	LS

CF MOTO ZEEHO			
	AE8	22 -23	HS



DUCATI			
	620 Multistrada	05 -06	HS
	695 Monster	07 -12	HS
	803 Monster S2R	05 -07	HS
	803 Monster S2R ABS	05 -07	HS
	937 DesertX	23 -24	LS
	937 DesertX Rally	24 -24	LS
	1103 Multistrada V4 RS	24 -24	LS
	1158 Multistrada V4 Pikes Peak	22 -24	LS
	1200 Multistrada	15 -16	LS
	1200 Multistrada S	15 -17	LS
	1200 Multistrada S D-air	15 -17	LS
	1200 Multistrada S Pikes Peak	16 -17	LS
	1200 Multistrada S Touring ABS	15 -16	LS
	1260 Multistrada	18 -18	LS
	1260 Multistrada S	18 -19	LS
	1260 Multistrada S D-air	18 -19	LS
	1260 Multistrada S Grand Tour	20 -20	LS
	1260 Multistrada S Pikes Peak	18 -19	LS

#### FACTORY

YR	250	99 -03	SI
----	-----	--------	----

#### GASGAS

	50 Wild HP	04 -07	SI SI
MC	85	21 -24	RSI
EC	125	97 -99	SI
MC	125	21 -24	RSI
	200 Wild HP	08 -09	SI SI
EC	200	99 -99	SI
EC	200 Ranger Enduro	19 -19	SI
	240 Wild HP	04 -06	SI SI
	250 Wild HP	08 -08	SI SI
EC	250	97 -99	SI
EC	250	21 -23	SI
EC	250 F	21 -23	SI
MC	250	97 -99	RSI
MC	250	21 -24	RSI
MC	250 F	21 -24	RSI
	300 Wild HP	03 -05	SI SI
EC	300	99 -99	SI
EC	300	21 -23	SI
EC	300 Ranger Enduro	19 -19	SI
EC	350 F	21 -23	SI
MC	350 F	22 -24	RSI
	450 Wild HP	03 -09	SI SI
MC	450 F	21 -24	RSI
	515 Wild HP	09 -09	SI SI

#### HARLEY DAVIDSON

X	440	24 -24	H.HF
XG	500 Street	16 -18	H.HF
XG	750 Street	16 -17	H.HF
XG	750 Street Rod	18 -20	H.HF

#### HIGHLAND

	450 MX	06 -09	RSI
	950 V2 Motard	00 -08	HF
	950 V2 Outback	99 -08	HF



HONDA			
NX	500 Dominator (Austria)	97 -99	HS

#### HUSABERG

	all models	93 -98	SI
TE	125	13 -13	SI
FE	250	13 -13	SI
TE	250	11 -13	SI
TE	300	11 -13	SI
FE	350	13 -13	SI
FE	390	10 -13	SI
FC	400	99 -02	RSI
FE	400 ,s,e	99 -03	SI
FC	450	03 -08	RSI
FE	450	09 -13	SI
FE	450 e	04 -08	SI
FX	450 e	03 -08	RSI
FC	470	01 -02	RSI
FX	470 e	01 -02	RSI
FC	501	99 -01	RSI
FE	501	13 -13	SI
FE	501 ,S,E	99 -04	SI
FC	550	01 -05	RSI
FE	550 e	04 -08	SI
FE	570	09 -13	SI
FC	600	99 -01	RSI
FE	600 ,s,e	99 -02	SI
FE	650 e	01 -08	SI
FX	650 e	01 -05	RSI

#### HUSQVARNA

TC	85	21 -24	RSI
CR	125	96 -13	RSI
SM	125 S	09 -13	HF
SM	125 S 4T	11 -13	HF
SM	125 Supermotard, S	99 -13	HF
TC	125	14 -24	RSI
TE	125	14 -16	SI
TE	125 4T	11 -13	HF
TX	125	17 -19	SI
WR	125	96 -13	SI
WRE	125	96 -13	SI
TE	150 i	20 -23	SI
CR	250	96 -05	RSI
FC	250	14 -24	RSI
FE	250	14 -23	SI
TC	250	02 -24	RSI
TE	250	02 -18	SI
TE	250 4T	10 -13	SI
TE	250 i	20 -23	SI
WR	250	96 -13	SI
TC	300	14 -15	RSI
TE	300	14 -19	SI
TE	300 i	18 -23	SI
TE	300 Pro	24 -24	SI
WR	300	09 -13	SI
TE	310 4T	10 -13	SI
FC	350	14 -24	RSI
FE	350	14 -23	SI
FE	350 Pro	24 -24	SI
TE	350	96 -13	SI
WR	360	98 -13	SI
TE	400	01 -13	SI
TE	410	96 -13	SI
TC	449	11 -13	RSI
TE	449	11 -13	SI
FC	450	14 -24	RSI
FE	450	14 -23	SI
FX	450	17 -20	SI
TC	450	02 -10	RSI

STREET  
AMERICAN  
SCOOTER

HF • HS • LS  
H.HF • H.CT • H.HS • H.LS  
HF • CT • MS

RACING  
OFF ROAD  
ATV

RST • DC • DCC • DS-1 • DS-2 • RQ  
SI • RSI • CS  
ATS • SI • RSI • PSI

Drawings 1:1

Available compounds

HF • HS • LS • RQ • CS • SI • RSI • H.HF • H.CT • H.LS

SBS 671

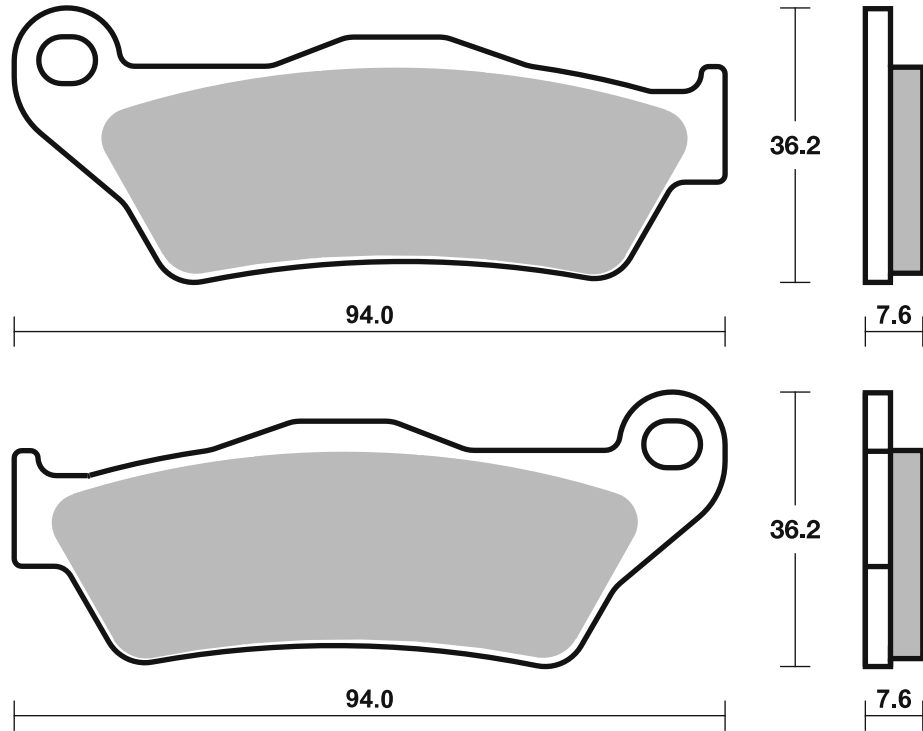



<b>HUSQVARNA</b>			
TE	450	02 - 10	<b>SI</b>
TE	450	14 - 14	<b>SI</b>
FE	501	14 - 23	<b>SI</b>
TC	510	02 - 10	<b>RSI</b>
TE	510	02 - 10	<b>SI</b>
TE	510 Centennial	04 - 05	<b>SI</b>
TE	511	11 - 14	<b>SI</b>
TC	570	01 - 13	<b>RSI</b>
TE	570	01 - 13	<b>SI</b>
TC	610	96 - 13	<b>RSI</b>
TE	610 Rally	96 - 13	<b>RSI</b>
TE	630	10 - 13	<b>HS</b>
TE	630	14 - 14	<b>SI</b>
	901 Norden	22 - 24	<b>LS</b>

<b>KAWASAKI</b>			
KX	450	24 - 24	<b>RSI</b>
KX	450 X	24 - 24	<b>SI</b>

<b>KRAM-IT</b>			
GS	250	97 - 00	<b>SI</b>
MX	250	97 - 00	<b>SI</b>
SM	250	97 - 00	<b>SI</b>

<b>KTM</b>			
SX	85 (17/14)	21 - 24	<b>RSI</b>
SX	85 (19/16)	21 - 24	<b>RSI</b>
	125 SuperMoto	00 - 03	<b>HF</b>
EGS	125	99 - 99	<b>HS</b>
EXC	125 Enduro	99 - 15	<b>SI</b>
EXE	125	00 - 00	<b>HF</b>
GS	125	92 - 97	<b>SI</b>
LC2	125	99 - 99	<b>HF</b>
MX	125	92 - 93	<b>SI</b>
SX	125	96 - 24	<b>RSI</b>
SXS	125	01 - 02	<b>RSI</b>
SX	144	07 - 08	<b>RSI</b>
EXC	150 TPI	20 - 23	<b>SI</b>
SX	150	09 - 23	<b>RSI</b>
XC-W	150	17 - 23	<b>SI</b>
EXC	200	99 - 00	<b>SI</b>
EXC	200 Enduro	99 - 16	<b>SI</b>
SX	200	03 - 04	<b>RSI</b>
EXC	250 Enduro	99 - 08	<b>SI</b>
EXC	250 Enduro 4T	99 - 06	<b>SI</b>
EXC	250 TPI	18 - 23	<b>SI</b>
EXC-F	250	07 - 23	<b>SI</b>
MX	250	92 - 93	<b>SI</b>
SX	250	96 - 24	<b>RSI</b>
SX-F	250	06 - 24	<b>RSI</b>
XC	250	06 - 14	<b>RSI</b>
EXC	300	93 - 96	<b>SI</b>
EXC	300 Enduro	99 - 08	<b>SI</b>
EXC	300 TPI	18 - 23	<b>SI</b>
MX	300	92 - 92	<b>SI</b>
SX	300	23 - 24	<b>RSI</b>
XC	300	06 - 14	<b>RSI</b>
EXC-F	350	11 - 23	<b>SI</b>
SX-F	350	11 - 24	<b>RSI</b>
MX	360	96 - 97	<b>SI</b>
SX	360	96 - 97	<b>RSI</b>
XC	360	96 - 97	<b>SI</b>
EXC	380 Enduro	99 - 99	<b>SI</b>
MX	380	98 - 98	<b>SI</b>
SX	380	98 - 02	<b>RSI</b>
XC	380	98 - 03	<b>SI</b>
EXC	400 Racing	00 - 07	<b>SI</b>
LC4	400	93 - 02	<b>SI</b>
LC4-E	400 Enduro	99 - 02	<b>SI</b>
SC	400	99 - 00	<b>SI</b>

<b>KTM</b>			
SX	400	00 - 02	<b>RSI</b>
SXC	400 Tiainen Replica	99 - 00	<b>SI</b>
EXC-F	450	04 - 23	<b>SI</b>
SX-F	450	03 - 24	<b>RSI</b>
XC-F	450	06 - 23	<b>RSI</b>
EXC-F	500	12 - 24	<b>SI</b>
MX	500	92 - 93	<b>SI</b>
SX	505	07 - 09	<b>RSI</b>
SX-F	505	07 - 08	<b>RSI</b>
XC-F	505	08 - 09	<b>RSI</b>
EXC	520 Racing	00 - 02	<b>SI</b>
SX-F	520	00 - 02	<b>RSI</b>
EXC	525 Racing	03 - 06	<b>SI</b>
SX-F	525	03 - 06	<b>RSI</b>
EXC	530 Racing	08 - 11	<b>SI</b>
SXC	540	98 - 98	<b>SI</b>
SXC	540 Tiainen Replica	99 - 00	<b>SI</b>
SXS	540	01 - 02	<b>RSI</b>
LC4	600 Six Days	92 - 92	<b>SI</b>
LC4	620 Competition	99 - 02	<b>SI</b>
LC4	620 Competition SuperMoto	00 - 01	<b>HF</b>
LC4	620 RXC	95 - 95	<b>SI</b>
LC4	620 Supercompetition	01 - 01	<b>HF</b>
SC	620	99 - 00	<b>SI</b>
SX	620	95 - 99	<b>RSI</b>
LC4	625 SC Supermoto	02 - 04	<b>HF</b>
SXC	625	03 - 04	<b>HF</b>
LC4	640 Adventure	99 - 04	<b>HF</b>
LC4-E	640 Enduro	99 - 04	<b>HF</b>
LC4-E	640 Supermoto	99 - 02	<b>HF</b>
LC4	660 Rally	01 - 03	<b>HF</b>
	790 Adventure	19 - 24	<b>LS</b>
	790 Adventure R	19 - 20	<b>LS</b>
	790 Adventure R Rally	20 - 20	<b>LS</b>
	890 Adventure R	21 - 24	<b>LS</b>
	890 Adventure R Rally	24 - 24	<b>LS</b>
	890 SMT	24 - 24	<b>LS</b>
	950 R Superenduro	06 - 08	<b>LS</b>
	950 SM	05 - 07	<b>LS</b>
	950 SM R	07 - 09	<b>LS</b>
LC8	950 Adventure	02 - 07	<b>LS</b>
	990 Adventure	06 - 11	<b>LS</b>
	990 Adventure R	10 - 12	<b>LS</b>
	990 Adventure S, ABS	06 - 11	<b>LS</b>
	990 Supermoto	07 - 11	<b>LS</b>
	990 Supermoto R	10 - 10	<b>LS</b>
	990 Supermoto T	09 - 13	<b>LS</b>
	1050 Adventure	15 - 16	<b>LS</b>
	1090 Adventure R	17 - 19	<b>LS</b>
	1090 Super Adventure	17 - 19	<b>LS</b>
	1090 Super Adventure R	17 - 20	<b>LS</b>
	1190 Adventure	13 - 16	<b>LS</b>
	1290 Super Adventure	15 - 16	<b>LS</b>
	1290 Super Adventure R	17 - 20	<b>LS</b>
	1290 Super Adventure S	17 - 23	<b>LS</b>
	1290 Super Adventure T	17 - 19	<b>LS</b>

<b>MAICO</b>			
	250 Motocross/Enduro	99 - 01	<b>SI</b>
	500 Motocross/Enduro	99 - 99	<b>SI</b>
	500 Supermotard	99 - 99	<b>HF</b>



<b>MBP</b>			
	1000 C1002V	23 - 23	<b>LS</b>
	1000 T1002V	23 - 23	<b>LS</b>

<b>MOTO-GUZZI</b>			
V100	1042 Mandello	22 - 23	<b>LS</b>
V100	1042 S Mandello	23 - 23	<b>LS</b>
V100	1042 Stelvio	24 - 24	<b>LS</b>
ES	1100 Quota	99 - 03	<b>HF</b>
V	1100 Breva, ABS	05 - 07	<b>LS</b>
	1200 Griso 8V	07 - 13	<b>LS</b>
	1200 Norge	06 - 14	<b>LS</b>
	1200 Norge GT 8V	10 - 13	<b>LS</b>
	1200 Sport	07 - 08	<b>LS</b>
	1200 Sport 8V	12 - 13	<b>LS</b>
	1200 Sport 8V SE	12 - 15	<b>LS</b>
	1200 Stelvio	08 - 11	<b>LS</b>
	1200 Stelvio 8V SE	12 - 16	<b>LS</b>
	1200 Stelvio NTX	09 - 11	<b>LS</b>
V	1200 Breva	08 - 13	<b>LS</b>

<b>MOTO-MORINI</b>			
	650 Seiemmezzo	20 - 23	<b>LS</b>
	1200 Granferro	10 - 10	<b>LS</b>
	1200 Granpasso	08 - 13	<b>LS</b>
	1200 GT	10 - 10	<b>LS</b>
	1200 Scrambler	09 - 10	<b>LS</b>

<b>MV AGUSTA</b>			
	550 Lucky Explorer	23 - 23	<b>LS</b>
	950 Lucky Explorer	23 - 23	<b>LS</b>

<b>PRAGA</b>			
ED	250	99 - 03	<b>SI</b>
CD	610	99 - 03	<b>SI</b>

<b>RIEJU</b>			
MRX	250 Marathon	10 - 12	<b>SI</b>
MRX	450 Marathon	08 - 12	<b>SI</b>

<b>ROYAL ENFIELD</b>			
	350 Classic	23 - 23	<b>HS</b>
	350 Meteor	23 - 23	<b>HS</b>
	411 Himalayan	19 - 23	<b>HF</b>
	500 Bullet	20 - 20	<b>HS</b>
	500 Bullet Trials	20 - 20	<b>HS</b>
	500 Classic	19 - 19	<b>HF</b>
	650 Super Meteor	23 - 23	<b>LS</b>

<b>SHERCO</b>			
SE-R	125	17 - 19	<b>SI</b>
SE	250 , R	14 - 14	<b>SI</b>
SE	250 2.5i Enduro	06 - 11	<b>SI</b>
SE	250 F, F-R	14 - 19	<b>SI</b>
SE	250 i/R	12 - 13	<b>SI</b>
SE	250 i-F	13 - 13	<b>SI</b>
SX	250 2.5i-F	09 - 11	<b>RSI</b>
SCF-R	300	16 - 19	<b>SI</b>
SE	300 , R	14 - 19	<b>SI</b>
SE	300 3.0i-F	10 - 11	<b>SI</b>
SE	300 F, F-R	14 - 19	<b>SI</b>
SE	300 i/R	12 - 13	<b>SI</b>
SE	300 i-F	13 - 13	<b>SI</b>
SE	450 4.5i Enduro	04 - 11	<b>SI</b>
SE	450 F, F-R	14 - 19	<b>SI</b>
SE	450 iR	12 - 13	<b>SI</b>
SE	510 5.1i Enduro	06 - 11	<b>SI</b>
SE	510 iR	12 - 13	<b>SI</b>

<b>STARK</b>			
	Varg	23 - 24	<b>RSI</b>



STREET  
AMERICAN  
SCOOTER

HF • HS • LS  
H.HF • H.CT • H.HS • H.LS  
HF • CT • MS

RACING  
OFF ROAD  
ATV

RST • DC • DCC • DS-1 • DS-2 • RQ  
SI • RSI • CS  
ATS • SI • RSI • PSI

Available compounds

HF • HS • LS • RQ • CS • SI • RSI • H.HF • H.CT • H.LS

SBS 671

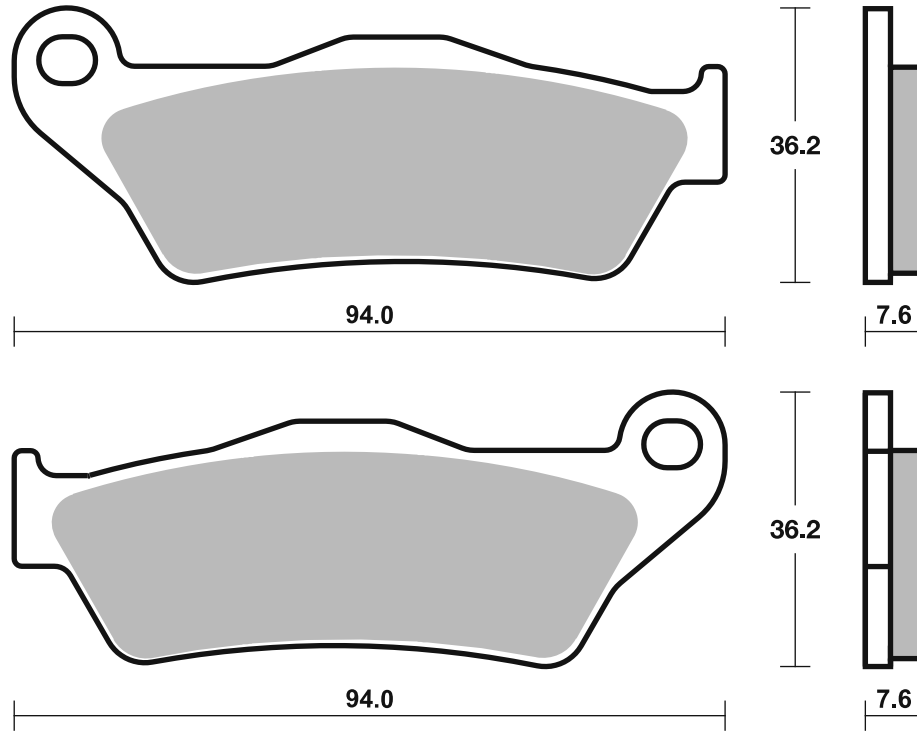

Applications

**SBS 671**

**Recommended compound**



<b>SWM</b>			
RS	300 R	15 - 20	<b>SI</b>
RS	500 R	15 - 20	<b>SI</b>
<b>TM</b>			
	80 Cross	96 - 00	<b>RSI</b>
MX	85	01 - 12	<b>RSI</b>
EN	125 Enduro	01 - 22	<b>SI</b>
MX	125	96 - 04	<b>RSI</b>
MX	144	08 - 24	<b>RSI</b>
	250 E	95 - 00	<b>RSI</b>
EN	250 Enduro	01 - 22	<b>SI</b>
EN	250 F Enduro	00 - 04	<b>SI</b>
MX	250	01 - 24	<b>RSI</b>
MX	250 F	01 - 24	<b>RSI</b>
EN	300 Enduro	01 - 05	<b>SI</b>
FT	300	17 - 19	<b>RSI</b>
MX	300	98 - 04	<b>RSI</b>
	320	96 - 97	<b>RSI</b>
	400 F	00 - 01	<b>RSI</b>
	400 F Enduro	01 - 01	<b>SI</b>
EN	450 F Enduro	02 - 22	<b>SI</b>
FT	450 Fi	17 - 19	<b>RSI</b>
MX	450 F	02 - 24	<b>RSI</b>
EN	530 F Enduro	01 - 05	<b>SI</b>
FT	530 Fi	17 - 19	<b>RSI</b>
MX	530 F	01 - 24	<b>RSI</b>
<b>TRIUMPH</b>			
TF	250 X	24 - 24	<b>RSI</b>
	800 Tiger XCA	18 - 18	<b>HS</b>
	800 Tiger XCX	18 - 20	<b>HS</b>



<b>TRIUMPH</b>			
	800 Tiger XRT	18 - 18	<b>HS</b>
	800 Tiger XRX	18 - 18	<b>HS</b>
	800 Tiger XRX Low	18 - 20	<b>HS</b>
	900 Bonneville T100	21 - 23	<b>HS</b>
	1200 Bonneville		
	Bobber	21 - 23	<b>HS</b>
	1200 Bonneville		
	Bobber Black	18 - 23	<b>HS</b>
	1200 Bonneville		
	Speedmaster	18 - 23	<b>HS</b>
	1200 Bonneville T120	21 - 23	<b>HS</b>
	1200 Bonneville T120		
	Black	21 - 23	<b>HS</b>
<b>VERTEMATI</b>			
C	500 Cross	02 - 04	<b>RSI</b>
E	501 Enduro	02 - 04	<b>SI</b>
S	501 Supermotard	02 - 04	<b>HF</b>
<b>VOR</b>			
	400 Cross	00 - 01	<b>RSI</b>
	400 Enduro	00 - 01	<b>SI</b>
EN	400	02 - 03	<b>SI</b>
MX	400	02 - 02	<b>RSI</b>
EN	450	02 - 04	<b>SI</b>
MX	450	02 - 04	<b>RSI</b>
	500 492 Enduro	99 - 99	<b>SI</b>
	500 495 Cross	99 - 99	<b>RSI</b>
EN	530	02 - 04	<b>SI</b>
MX	530	02 - 04	<b>RSI</b>



<b>WRM</b>			
	450 MX	06 - 08	<b>RSI</b>
<b>YAMAHA</b>			
YZF	125 R	08 - 13	<b>HF</b>
FZH	150 Fazer	11 - 14	<b>HF</b>
MT-15	155	18 - 21	<b>HS</b>
YZF	155 R	19 - 21	<b>HS</b>
FZ25	250	19 - 19	<b>HF</b>
TT	600 E,S	96 - 01	<b>HF</b>
TT	600 R	93 - 95	<b>HF</b>
TT	600 R	98 - 07	<b>HF</b>
XT	660 Z Tenere	08 - 15	<b>HS</b>
XT	660 Z Tenere ABS	11 - 15	<b>HS</b>
XTZ	700 Tenere	19 - 24	<b>HS</b>
XTZ	700 Tenere Explore	19 - 24	<b>HS</b>
XTZ	700 Tenere Extreme	19 - 24	<b>HS</b>
XTZ	700 Tenere World		
	Raid	19 - 24	<b>HS</b>
XTZ	700 Tenere World		
	Rally	19 - 24	<b>HS</b>
<b>ZERO</b>			
DS	ZF17.3	24 - 24	<b>LS</b>
DSR/X	ZF17.3	23 - 23	<b>LS</b>
FX	ZF2.8	15 - 15	<b>HS</b>
FX	ZF5.7	15 - 15	<b>HS</b>

**SBS 672**

**Recommended compound**



<b>BETA</b>			
TR	125 34	92 - 92	<b>HF</b>
TR	125 36	92 - 92	<b>HF</b>
<b>CAGIVA</b>			
	50 Prima	93 - 94	<b>HF</b>
	80 Prima	92 - 92	<b>HF</b>

STREET  
AMERICAN  
SCOOTER

HF • HS • LS  
H.HF • H.CT • H.HS • H.LS  
HF • CT • MS

RACING  
OFF ROAD  
ATV

RST • DC • DCC • DS-1 • DS-2 • RQ  
SI • RSI • CS  
ATS • SI • RSI • PSI

Drawings 1:1

Available compounds

HF • HS • LS • RQ • CS • SI • RSI • H.HF • H.CT • H.LS

SBS 671

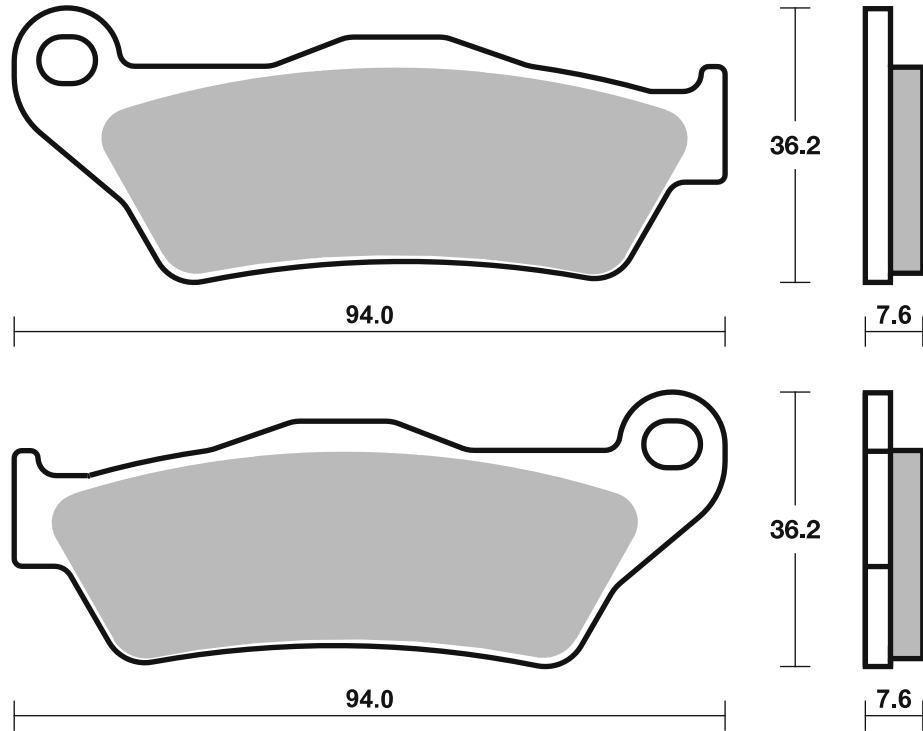

Available compounds

HF

SBS 672

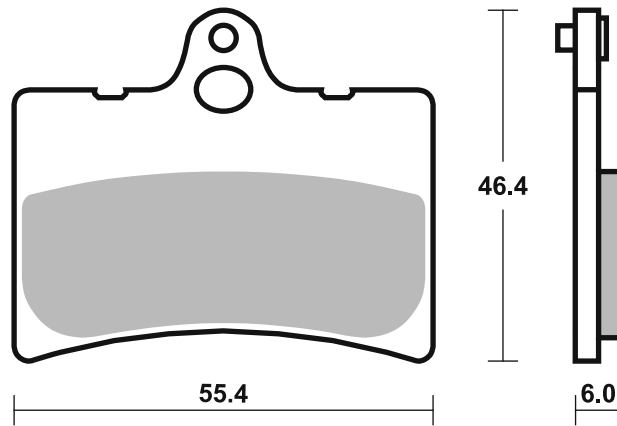



APRILIA			
650 Moto	95 -03	HF	
650 Pegaso	95 -00	HS	
650 Pegaso i.e.	01 -04	HS	
650 Pegaso i.e.			
Tuscany Tibet			
Raid	04 -04	HS	
650 Pegaso Trail	06 -08	HS	
650 Starck	96 -01	HF	
660 Tuareg	22 -24	HS	
ETV 1000 Caponord	01 -08	HS	
ETV 1000 Caponord Rally			
Raid	04 -08	HS	

BIMOTA			
DBX 1100	13 -18	HS	

BMW			
F 650 ,ST	94 -00	HF	
F 650 CS Scarver	02 -06	HS	
F 650 GS	08 -12	HS	
F 650 GS ABS	01 -07	HF	
F 650 GS ABS	08 -12	HS	
F 650 GS Dakar	01 -07	HF	
F 650 GS, Rally	01 -07	HF	
F 650 ST Strada	97 -01	HF	
G 650 GS	09 -15	HS	
G 650 GS Sertao	12 -14	HS	
G 650 Xchallenge	06 -07	HS	
G 650 Xcountry	06 -09	HS	
F 700 GS	13 -16	HS	
F 750 GS	18 -24	HS	
F 800 GS	08 -24	HS	
F 850 GS	18 -23	HS	
F 850 GS Adventure	18 -23	HS	
F 900 GS	24 -24	HS	
F 900 GS Adventure	24 -24	HS	
1200 HP2 Enduro	04 -06	HS	
R 1200 GS	13 -18	LS	
R 1200 GS Adventure	14 -18	LS	
R 1200 R	15 -18	LS	
R 1200 RS	14 -18	LS	
R 1200 RT	14 -18	LS	
R 1250 GS	19 -23	LS	
R 1250 GS Adventure	19 -24	LS	
R 1250 R	19 -24	LS	
R 1250 RS	19 -24	LS	
R 1250 RT	19 -24	LS	
R 1250 RT Sport	19 -20	LS	
K 1600 B	17 -24	LS	
K 1600 Grand America	18 -24	LS	
K 1600 GT	11 -24	LS	
K 1600 GTL	11 -24	LS	

CF MOTO			
400 NK Efi	17 -17	HS	
650 MT	19 -22	HS	
650 NK	14 -16	HS	
650 NK Efi	17 -17	HS	
650 TK	14 -15	HS	
700 MT	24 -24	HS	

DUCATI			
400 Scrambler			
Sixty Two	16 -20	HS	
1000 Biposto	07 -08	HS	
1000 GT	05 -10	HS	
1000 GT Touring	09 -10	HS	
1000 Paul Smart	05 -08	HS	
1000 Sport	05 -09	HS	
1000 Sport S	05 -09	HS	

DUCATI			
1158 Diavel V4	23 -24	LS	
1200 Diavel	11 -18	LS	
1200 Diavel Carbon	14 -23	LS	
1200 Diavel Dark	14 -23	LS	
1200 Diavel Strada	11 -14	LS	
1200 Diavel Titanium	15 -23	LS	
1200 Xdiavel	16 -18	LS	
1200 Xdiavel S	16 -18	LS	
1260 Diavel	19 -22	LS	
1260 Diavel			
Lamborghini	20 -23	LS	
1260 Diavel S	19 -22	LS	
1262 Xdiavel	19 -23	LS	
1262 Xdiavel Black			
Star	20 -23	LS	
1262 Xdiavel Dark	22 -24	LS	
1262 Xdiavel Nera	24 -24	LS	
1262 Xdiavel S	19 -24	LS	

GASGAS			
RX 450 F	23 -23	SI	
ES 700	23 -23	HS	

HARLEY DAVIDSON			
XG 500 Street	16 -18	H.HF	
XG 750 Street	16 -17	H.HF	
XG 750 Street Rod	18 -20	H.HF	

HONDA			
CBR 250 R (Bybre cal)	11 -11	HS	
CB 500	97 -05	HS	
CB 500 S	98 -03	HS	
FX 650 Vigor	99 -02	HS	
NT 650 V Deauville	98 -01	HS	
NX 650 Dominator	97 -99	HS	
SLR 650	97 -99	HS	

HUSQVARNA			
FR 450 Rally	22 -23	SI	
TR 650 Strada	13 -13	HS	
TR 650 Terra	13 -13	HS	
701 Enduro LR	20 -20	HS	
FE 701 Enduro	17 -20	HS	

INDIAN			
1000 Scout Sixty	17 -18	H.HS	
1200 Rogue	22 -23	H.HS	
1200 Scout	17 -23	H.HS	
1200 Scout Bobber	17 -23	H.HS	

KEEWAY			
M 502 N	23 -23	HS	

KTM			
450 Rally	11 -17	SI	
450 Rally	19 -22	SI	
LC4 640 Adventure	05 -07	HF	
690 Enduro	08 -14	HS	
690 Enduro R	09 -23	HS	
950 R Superenduro	06 -08	HS	
LC8 950 Adventure	02 -07	HS	
990 Adventure	06 -11	HS	
990 Adventure R	10 -12	HS	
990 Adventure S,			
ABS	06 -11	HS	

MBP			
M 502 N	23 -23	HS	



MOTO-GUZZI			
940 Custom	07 -07	LS	
1100 California EV	06 -06	LS	
1100 California EV			
Touring	06 -06	LS	
1100 California Jackal	00 -00	HF	
1100 California Jackal	01 -06	LS	
1100 California Jackal			
Basic	00 -00	HF	
1100 California Jackal			
Basic	01 -06	LS	
1100 California Special	99 -00	HF	
1100 California Special	01 -01	LS	
1100 California Special			
Sport Alloy	02 -06	LS	
1100 California Stone			
Metal	02 -03	LS	
1100 California Stone,			
Stone Touring	02 -05	LS	
1100 California			
Titanium	03 -05	LS	
1100 California Vintage	06 -13	LS	
1100 Griso	05 -10	LS	
ES 1100 Quota	99 -03	HF	
1400 Audace	15 -17	LS	
1400 California Custom	13 -15	LS	
1400 California Touring	13 -15	LS	
1400 California Touring			
SE	16 -17	LS	
1400 Eldorado	15 -17	LS	
MGX-21 1400 Flying Fortress	15 -17	LS	

MOTO-MORINI			
649 X-Cape	20 -23	HS	
650 Calibro	24 -24	HS	
650 Seiemmezzo	20 -23	HS	
1200 Granpasso	08 -13	HS	
1200 GT	10 -10	HS	
1200 Scrambler	09 -10	HS	

ROYAL ENFIELD			
451 Himalayan	24 -24	HS	
535 Continental GT	14 -19	HS	
650 Continental GT	20 -23	HS	
650 Interceptor	19 -23	HS	
650 Super Meteor	23 -23	HS	

SWM			
600 Superdual GT			
Pack	18 -18	HS	
600 Superdual T	18 -20	HS	
600 Superdual X	18 -20	HS	

TRIUMPH			
1200 Scrambler X	24 -24	LS	
1200 Scrambler XC	19 -23	LS	
1200 Scrambler XE	19 -24	LS	
1600 Thunderbird	09 -18	LS	
1700 Thunderbird			
Commander	14 -18	LS	
1700 Thunderbird LT	14 -18	LS	
1700 Thunderbird			
Nightstorm	14 -18	LS	
1700 Thunderbird			
Storm	11 -18	LS	
2300 Rocket 3 Classic	07 -13	LS	
2300 Rocket 3			
Roadster	10 -18	LS	
2300 Rocket 3 Touring	13 -14	LS	
2300 Rocket III	04 -13	LS	
2300 Rocket X	15 -15	LS	

STREET  
AMERICAN  
SCOOTER

HF • HS • LS  
H.HF • H.CT • H.HS • H.LS  
HF • CT • MS

RACING  
OFF ROAD  
ATV

RST • DC • DCC • DS-1 • DS-2 • RQ  
SI • RSI • CS  
ATS • SI • RSI • PSI

Drawings 1:1

Available compounds

HF • HS • LS • RST • SI • RSI • H.HF • H.CT • H.HS • H.LS

SBS 674

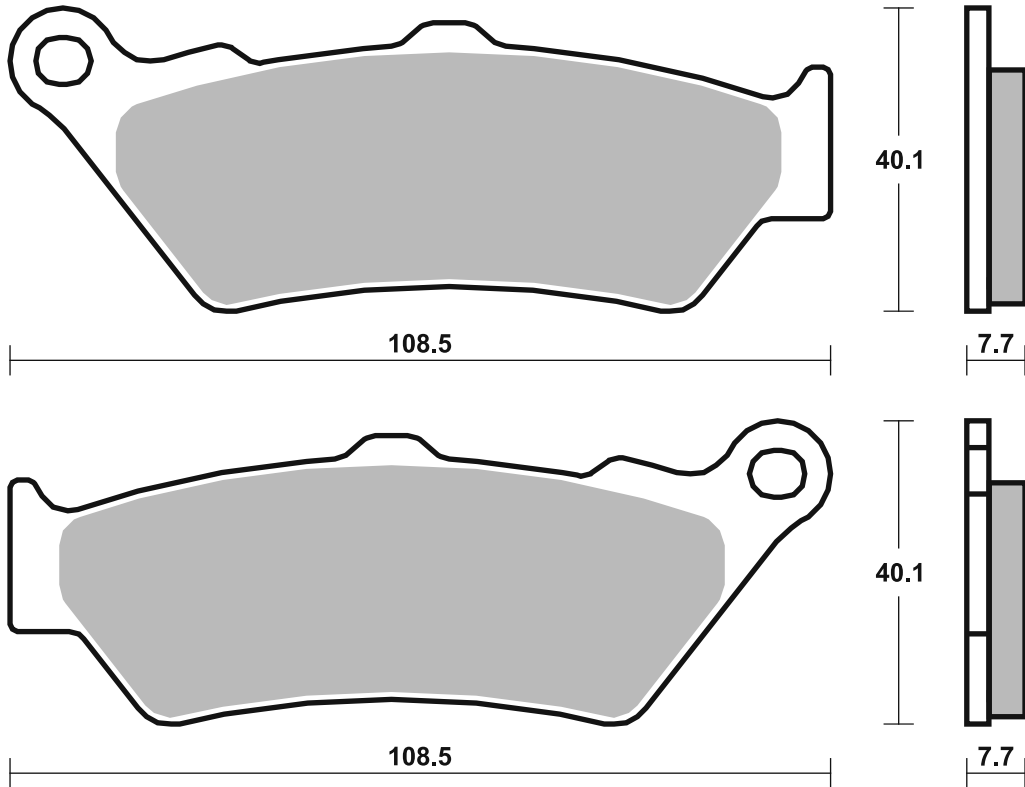

## Applications

### SBS 674

### Recommended compound



<b>VICTORY</b>			
1200 Octane	17 - 17	<b>H.HS</b>	
1500 Kingpin	04 - 05	<b>H.LS</b>	
1500 Touring Cruiser	03 - 06	<b>H.LS</b>	
1500 V92C Cruiser	98 - 02	<b>H.LS</b>	
1500 V92C Deluxe	01 - 02	<b>H.LS</b>	
1500 V92SC Sport Cruiser	00 - 02	<b>H.LS</b>	
1500 Vegas	03 - 05	<b>H.LS</b>	
1500 Vegas 8-Ball	05 - 05	<b>H.LS</b>	
1634 Hammer	05 - 07	<b>H.LS</b>	
1634 Hammer S	06 - 08	<b>H.LS</b>	
1634 Kingpin	06 - 07	<b>H.LS</b>	
1634 Kingpin Tour	06 - 07	<b>H.LS</b>	
1634 Vegas	06 - 07	<b>H.LS</b>	
1634 Vegas 8-Ball	06 - 07	<b>H.LS</b>	
1634 Vegas Jackpot	06 - 07	<b>H.LS</b>	

<b>VOGE</b>			
900 DSX	24 - 24	<b>HS</b>	
900 DS Valico	23 - 23	<b>HS</b>	

<b>YAMAHA</b>			
DT 125 X Supermotard	05 - 08	<b>HF</b>	
XT 660 R	04 - 11	<b>HS</b>	

<b>ZERO</b>			
DS ZF12.5	15 - 15	<b>HS</b>	
DS ZF13.0	16 - 17	<b>HS</b>	
DS ZF9.4	15 - 15	<b>HS</b>	
DS ZF9.8	16 - 17	<b>HS</b>	
DSR ZF13.0	16 - 17	<b>HS</b>	



<b>ZERO</b>			
FX ZF3.3	16 - 17	<b>HS</b>	
FX ZF6.5	16 - 17	<b>HS</b>	
FXE ZF7.2	21 - 22	<b>HS</b>	
FXS ZF3.3	16 - 17	<b>HS</b>	
FXS ZF3.6	16 - 22	<b>HS</b>	
FXS ZF6.5	16 - 17	<b>HS</b>	
S ZF12.5	15 - 15	<b>HS</b>	
S ZF13.0	16 - 17	<b>HS</b>	
S ZF9.4	15 - 15	<b>HS</b>	
S ZF9.8	16 - 17	<b>HS</b>	
SR ZF12.5	15 - 15	<b>HS</b>	
SR ZF13.0	16 - 17	<b>HS</b>	

### SBS 675

### Recommended compound



<b>ALFER</b>			
VRE 125 4-stroke	00 - 00	<b>SI</b>	
VR 250 Cross	99 - 99	<b>RSI</b>	
VR 250 Enduro	99 - 99	<b>SI</b>	
VR 250 No Limit	99 - 99	<b>RSI</b>	
VR 250 Supermotard	99 - 99	<b>RSI</b>	

<b>APRILIA</b>			
RS 457	24 - 24	<b>LS</b>	
650 Pegaso Factory	07 - 09	<b>LS</b>	
650 Pegaso i.e.	01 - 04	<b>LS</b>	
650 Pegaso i.e. Tuscany Tibet			
Raid	04 - 04	<b>LS</b>	
650 Pegaso Strada	05 - 09	<b>LS</b>	
650 Pegaso Trail	06 - 08	<b>LS</b>	
660 Tuareg	22 - 24	<b>LS</b>	
750 Dorsoduro			
Factory	12 - 13	<b>LS</b>	
SL 750 Shiver GT, ABS	09 - 12	<b>LS</b>	
SL 750 Shiver, ABS	07 - 18	<b>LS</b>	
SMV 750 Dorsoduro	08 - 18	<b>LS</b>	
NA 850 Mana	07 - 07	<b>LS</b>	
900 Dorsoduro	18 - 20	<b>LS</b>	
900 Shiver	18 - 20	<b>LS</b>	
1200 Caponord	13 - 19	<b>LS</b>	
1200 Caponord Rally	15 - 19	<b>LS</b>	
1200 Caponord Travel			
Pack	16 - 19	<b>LS</b>	
1200 Dorsoduro, ABS	11 - 14	<b>LS</b>	

<b>BENELLI</b>			
BX 449 Cross	07 - 09	<b>RSI</b>	
BX 449 Supermotard	08 - 10	<b>RSI</b>	
500 Tornado	24 - 24	<b>LS</b>	
BX 505 Enduro	08 - 08	<b>SI</b>	
TRK 702	24 - 24	<b>LS</b>	
TRK 702 X	24 - 24	<b>LS</b>	

<b>BETA</b>			
125 Jonathan	99 - 05	<b>HF</b>	
350 Euro	99 - 03	<b>HF</b>	
350 Jonathan	02 - 03	<b>HF</b>	

<b>BMW</b>			
G 310 GS	17 - 24	<b>LS</b>	
G 310 R	16 - 24	<b>LS</b>	
F 650 , ST	94 - 00	<b>HF</b>	
F 650 CS Scarver	02 - 06	<b>LS</b>	
F 650 GS	08 - 12	<b>LS</b>	
F 650 GS ABS	01 - 07	<b>HF</b>	
F 650 GS ABS	08 - 12	<b>LS</b>	
F 650 GS Dakar	01 - 07	<b>HF</b>	
F 650 GS, Rally	01 - 07	<b>HF</b>	
F 650 ST Strada	97 - 01	<b>HF</b>	
G 650 GS	09 - 15	<b>LS</b>	
G 650 GS Sertao	12 - 14	<b>LS</b>	
G 650 Xchallenge	06 - 07	<b>LS</b>	
G 650 Xcountry	06 - 09	<b>LS</b>	
G 650 Xmoto	06 - 07	<b>LS</b>	
F 700 GS	13 - 16	<b>LS</b>	
F 750 GS	18 - 24	<b>LS</b>	
F 800 GS	08 - 24	<b>LS</b>	

<b>BMW</b>			
F 800 GT	13 - 20	<b>LS</b>	
F 800 R	09 - 18	<b>LS</b>	
F 800 S	06 - 10	<b>LS</b>	
F 800 ST	06 - 12	<b>LS</b>	
F 800 ST Touring	11 - 12	<b>LS</b>	
F 850 GS	18 - 23	<b>LS</b>	
F 850 GS Adventure	18 - 23	<b>LS</b>	
R 850 RT	96 - 01	<b>LS</b>	
F 900 GS	24 - 24	<b>LS</b>	
F 900 GS Adventure	24 - 24	<b>LS</b>	
F 900 R	20 - 24	<b>LS</b>	
F 900 XR	20 - 24	<b>LS</b>	
M 1000 R	23 - 24	<b>LS</b>	
S 1000 R	13 - 24	<b>LS</b>	
S 1000 RR (Hayes cal.)	09 - 21	<b>LS</b>	
S 1000 RR (Nissin cal.)	21 - 24	<b>LS</b>	
S 1000 RR ABS	09 - 21	<b>LS</b>	
S 1000 RR HP4	12 - 14	<b>LS</b>	

<b>BORILE</b>			
B 500 CR, MT	02 - 04	<b>HF</b>	

<b>BREMBO RACING CALIPERS</b>			
Motocross Caliper 22.2180.20			

<b>BRIXTON</b>			
BX 500 Crossfire	15 - 23	<b>LS</b>	
BX 500 X Crossfire	15 - 23	<b>LS</b>	
BX 500 XC Crossfire	15 - 23	<b>LS</b>	

STREET  
AMERICAN  
SCOOTER

HF • HS • LS  
H.HF • H.CT • H.HS • H.LS  
HF • CT • MS

RACING  
OFF ROAD  
ATV

RST • DC • DCC • DS-1 • DS-2 • RQ  
SI • RSI • CS  
ATS • SI • RSI • PSI

Drawings 1:1

Available compounds

HF • HS • LS • RST • SI • RSI • H.HF • H.CT • H.HS • H.LS

SBS 674

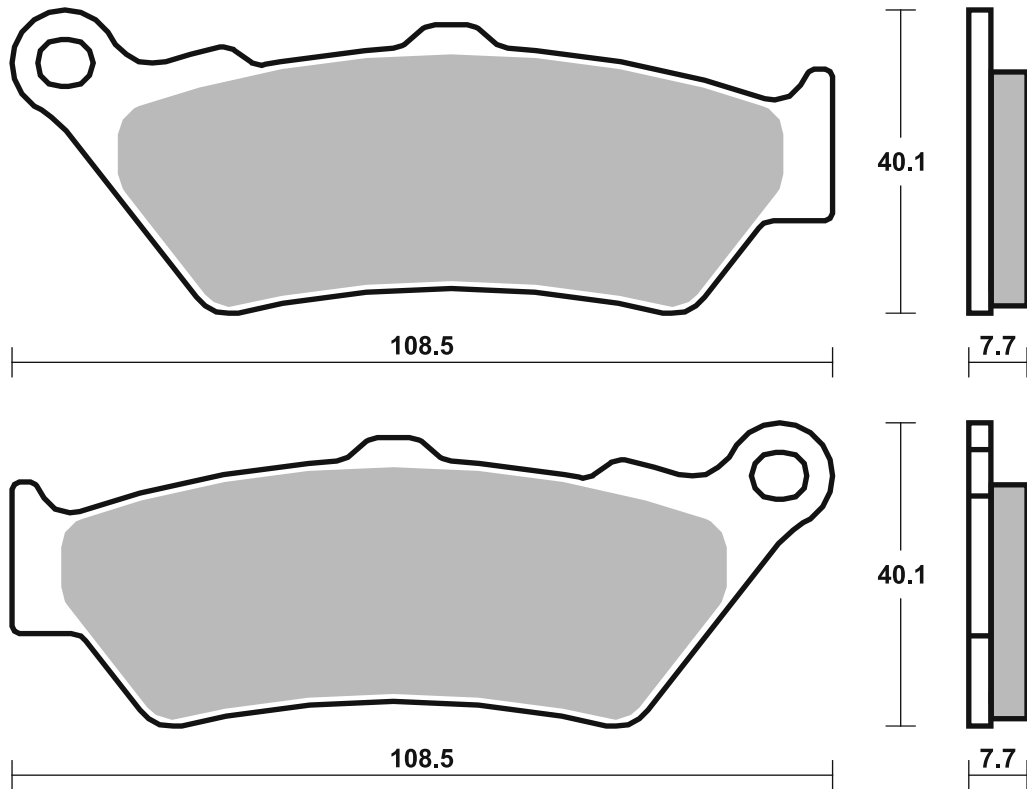

Available compounds

HF • LS • RQ • CS • SI • RSI • H.HF • H.CT • H.LS

SBS 675

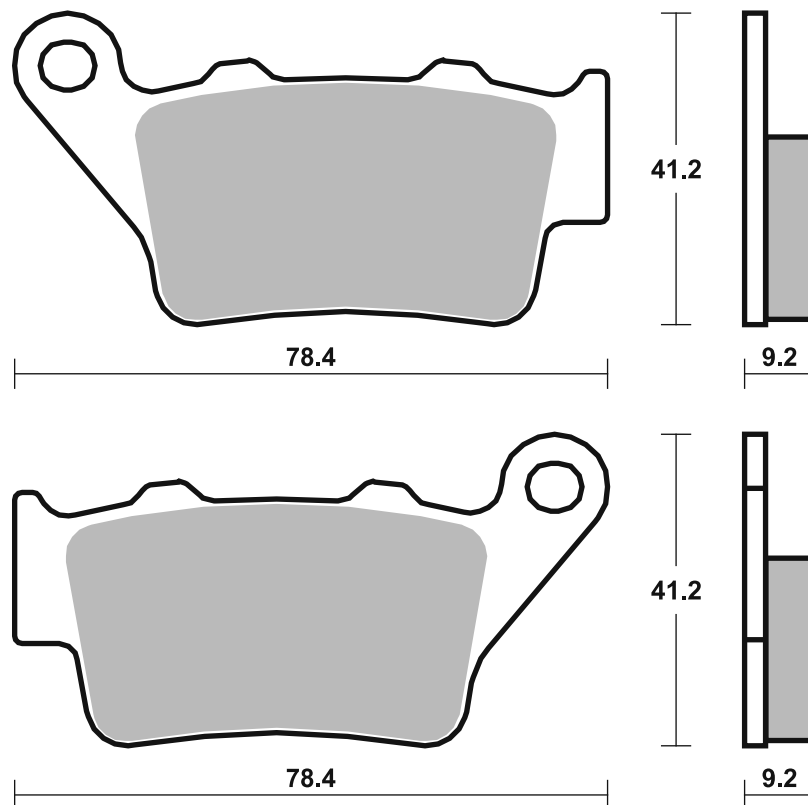



CCM			
GP	450	16 - 16	SI
604	600 RS	01 - 01	HF
604E	600 Sport	99 - 01	SI
604E	600 Supermoto	99 - 01	SI
C25	600	96 - 98	SI
	644 DS	03 - 06	HF
	644 R30	02 - 06	HF

## CF MOTO

	400 NK Efi	17 - 17	LS
	450 MT	24 - 24	LS
	650 MT	19 - 22	LS
	650 NK	14 - 16	LS
	650 NK Efi	17 - 17	LS
	650 TK	14 - 15	LS
	700 MT	24 - 24	LS

## DUCATI

	400 Scrambler		
	Sixty Two	16 - 20	LS
	698 Hypermotard		
	Mono	24 - 24	LS
	797 Monster	17 - 21	LS
	797 Monster+	17 - 20	LS
	803 Scrambler	17 - 18	LS
	803 Scrambler		
	Classic	15 - 19	LS
	803 Scrambler CR	17 - 20	LS
	803 Scrambler CR		
	Cafe Racer	17 - 20	LS
	803 Scrambler		
	Desert Sled	17 - 23	LS
	803 Scrambler		
	Enduro	15 - 16	LS
	803 Scrambler		
	Flat Track Pro	16 - 16	LS
	803 Scrambler		
	Full Throttle	15 - 24	LS
	803 Scrambler Icon	15 - 24	LS
	803 Scrambler Icon		
	Dark	20 - 23	LS
	803 Scrambler		
	Mach 2.0	18 - 18	LS
	803 Scrambler		
	Nightshift	20 - 24	LS
	803 Scrambler		
	SCR	20 - 20	LS
	803 Scrambler		
	Street Classic	17 - 18	LS
	803 Scrambler Urban		
	Enduro	15 - 18	LS
	803 Scrambler Urban		
	Motard	22 - 23	LS
	1000 Biposto	07 - 08	LS
	1000 GT	05 - 10	LS
	1000 GT Touring	09 - 10	LS
	1000 Paul Smart	05 - 08	LS
	1000 Sport	05 - 09	LS
	1000 Sport S	05 - 09	LS
	1100 Scrambler	18 - 19	LS
	1100 Scrambler		
	Dark Pro	20 - 24	LS
	1100 Scrambler		
	Desert X	20 - 20	LS
	1100 Scrambler Pro	20 - 23	LS
	1100 Scrambler		
	Special	18 - 19	LS
	1100 Scrambler Sport	18 - 19	LS
	1100 Scrambler Sport		
	Pro	20 - 24	LS



DUCATI			
	1100 Scrambler		
	Tribute Pro	22 - 24	LS

## FACTORY

YR	250	99 - 03	SI
----	-----	---------	----

## FANTIC

	125 Caballero Deluxe	23 - 23	HF
	125 Caballero Flat		
	Track	17 - 23	LS
	125 Caballero Rally	22 - 23	HF
	125 Caballero		
	Scrambler	22 - 23	HF
	500 Caballero	17 - 17	LS
	500 Caballero		
	Anniversary	23 - 23	LS
	500 Caballero Deluxe	23 - 23	LS
	500 Caballero		
	Explorer	22 - 23	HF
	500 Caballero Flat		
	Track	23 - 23	LS
	500 Caballero Rally	22 - 23	HF
	500 Caballero		
	Scrambler	22 - 23	HF
	500 Caballero		
	Six Days	22 - 22	HF

## GASGAS

EC	125	97 - 99	SI
EC	200	99 - 99	SI
EC	250	97 - 99	SI
MC	250	97 - 99	RSI
EC	300	99 - 99	SI
ES	700	23 - 23	LS
SM	700	23 - 23	LS

## HARLEY DAVIDSON

X	440	24 - 24	H.HF
	975 Bronx	20 - 21	H.LS
RA	1250 Pan America	21 - 22	H.LS
RA	1250 Pan America		
	Special	21 - 22	H.LS

## HIGHLAND

	450 MX	06 - 09	RSI
	950 V2 Motard	00 - 08	HF
	950 V2 Outback	99 - 08	HF

## HONDA

CBR	250 R (Bybre cal)	11 - 11	LS
CB	500	97 - 05	LS
CB	500 S	98 - 03	LS
NX	500 Dominator		
	(Austria)	97 - 99	LS
FX	650 Vigor	99 - 02	LS
NX	650 Dominator	97 - 99	LS
SLR	650	97 - 99	LS

## HRD

	50 GS Enduro	00 - 02	HF
--	--------------	---------	----

## HUSABERG

FC	400	99 - 02	RSI
FE	400 ,s,e	99 - 03	SI
FS	400 e, c	01 - 03	RSI
FC	450	03 - 08	RSI
FE	450 e	04 - 08	SI
FS	450 c	06 - 08	RSI
FS	450 e, c	03 - 05	RSI
FX	450 e	03 - 08	RSI



HUSABERG			
FC	470	01 - 02	RSI
FX	470 e	01 - 02	RSI
FC	501	99 - 01	RSI
FE	501 ,S,E	99 - 04	SI
FC	550	01 - 05	RSI
FE	550 e	04 - 08	SI
FC	600	99 - 01	RSI
FE	600 ,s, e	99 - 02	SI
FE	650 e	01 - 08	SI
FS	650 e, c	01 - 08	RSI
FX	650 e	01 - 05	RSI

## HUSQVARNA

	125 Svartpilen	21 - 23	LS
CR	125	96 - 04	RSI
SM	125 S	09 - 13	HF
SM	125 S 4T	11 - 13	HF
SM	125 Supermotard, S	99 - 13	HF
TE	125 4T	11 - 13	HF
WR	125	96 - 13	SI
WRE	125	96 - 13	SI
CR	250	96 - 04	RSI
TC	250	02 - 03	RSI
TE	250	02 - 13	SI
WR	250	96 - 13	SI
TE	350	96 - 13	SI
WR	360	98 - 13	SI
SM	400 R	02 - 02	HF
TE	400	01 - 13	SI
	401 Svartpilen	17 - 23	LS
	401 Vitpilen	17 - 23	LS
TE	410	96 - 13	SI
SM	450 R	03 - 04	HF
SM	450 R	05 - 05	RSI
TC	450	02 - 03	RSI
TE	450	02 - 10	SI
SM	510 R	05 - 05	RSI
TC	510	02 - 03	RSI
TE	510	02 - 10	SI
TE	510 Centennial	04 - 05	SI
	570 Nox	01 - 03	HF
SM	570 R	01 - 08	HF
TC	570	01 - 13	RSI
TE	570	01 - 13	SI
LT	610	00 - 02	HF
SM	610 Super Motard, S	98 - 00	HF
TC	610	96 - 13	RSI
TE	610 Rally	96 - 13	RSI
SMR	630	04 - 08	RSI
TR	650 Strada	13 - 13	LS
TR	650 Terra	13 - 13	LS
	701 Enduro LR	20 - 20	LS
	701 Svartpilen	18 - 19	LS
	701 Vitpilen	18 - 20	LS
FE	701 Enduro	17 - 20	LS
SM	701 Supermoto	15 - 20	LS
	900 Nuda	12 - 13	LS
	900 Nuda R, ABS	12 - 13	LS

## HYOSUNG

RX	450 SM	08 - 11	LS
----	--------	---------	----

## INDIAN

	1000 Scout Sixty	17 - 18	H.LS
	1200 Rogue	22 - 23	H.LS
	1200 Scout	17 - 23	H.LS
	1200 Scout Bobber	17 - 23	H.LS

## KEEWAY

M	502 N	23 - 23	LS
---	-------	---------	----



STREET  
AMERICAN  
SCOOTER

HF • HS • LS  
H.HF • H.CT • H.HS • H.LS  
HF • CT • MS

RACING  
OFF ROAD  
ATV

RST • DC • DCC • DS-1 • DS-2 • RQ  
SI • RSI • CS  
ATS • SI • RSI • PSI

Drawings 1:1

Available compounds

HF • LS • RQ • CS • SI • RSI • H.HF • H.CT • H.LS

SBS 675

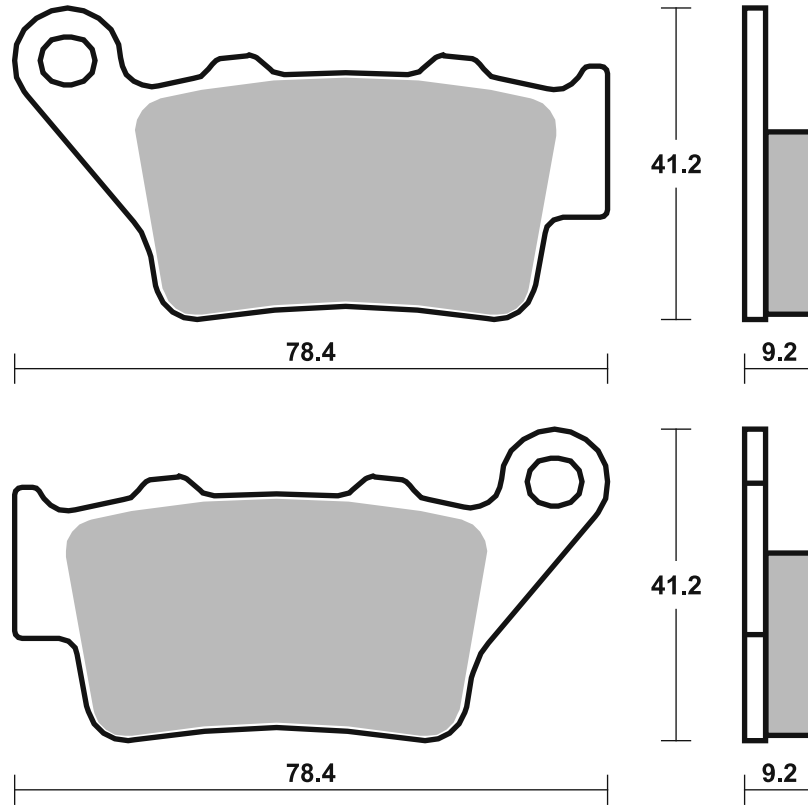



<b>KRAM-IT</b>			
GS	250 SMR	00 -00	RSI
MX	250	97 -00	SI
SM	250	97 -00	SI
<b>KTM</b>			
EGS	125 Duke	11 -19	LS
EXC	125 Sting	99 -99	HF
LC2	125 SuperMoto	00 -03	HF
EXC	125	99 -99	LS
EXC	125 Enduro	99 -03	SI
EXE	125	00 -00	HF
LC2	125	99 -99	HF
RC	125	14 -22	LS
SX	125	96 -03	RSI
SXS	125	01 -02	RSI
	200 Duke	12 -17	LS
EXC	200	99 -00	SI
EXC	200 Enduro	99 -03	SI
RC	200	14 -22	LS
	250 Duke	14 -15	LS
EXC	250 Enduro	99 -03	SI
EXC	250 Enduro 4T	99 -03	SI
RC	250	14 -15	LS
RC	250 Upgrade DS	14 -15	LS
RC4R	250	20 -20	RQ
SX	250	96 -02	RSI
EXC	300 Enduro	99 -03	SI
MX	360	96 -97	SI
SX	360	96 -97	RSI
XC	360	96 -97	SI
EXC	380 Enduro	99 -99	SI
MX	380	98 -98	SI
SX	380	98 -02	RSI
XC	380	98 -03	SI
	390 Adventure	20 -23	LS
	390 Adventure SW	23 -23	LS
	390 Duke	13 -23	LS
RC	390	14 -23	LS
RC	390 Upgrade DS	14 -23	LS
EXC	400 Racing	00 -03	SI
LC4-E	400 Enduro	99 -02	SI
SC	400	99 -00	SI
SX	400	00 -02	RSI
SXC	400 Tiainen		
	Replica	99 -00	SI
	450 Rally	11 -17	SI
EXC	520 Racing	00 -02	SI
SX-F	520	00 -02	RSI
EXC	525 Racing	03 -03	SI
SX-F	525	03 -03	RSI
SXC	540	98 -98	SI
SXC	540 Tiainen Replica	99 -00	SI
SXS	540	01 -02	RSI
LC4	620 Competition	99 -02	SI
LC4	620 Competition		
	SuperMoto	00 -01	HF
LC4	620 RXC	95 -95	SI
LC4	620 Supercompetition	01 -01	HF
SC	620	99 -00	SI
SX	620	95 -99	RSI
LC4	625 SC Supermoto	02 -04	HF
SMC	625	05 -06	HF
SXC	625	03 -04	HF
	640 Duke	03 -06	HF
LC4	640 Adventure	99 -07	HF
LC4	640 Supermoto	03 -04	HF
LC4-E	640 Enduro	99 -04	HF
LC4-E	640 Supermoto	99 -02	HF
LC4	660 Rally	01 -03	HF



<b>KTM</b>			
LC4	660 SM Factory		
	Replica	02 -02	RSI
<b>SMC</b>			
	660 Supermoto	03 -07	HF
	690 Duke	08 -11	LS
	690 Duke ABS	12 -19	LS
	690 Duke R	10 -11	LS
	690 Duke R	14 -17	LS
	690 Enduro	08 -14	LS
	690 Enduro R	09 -23	LS
	690 SM	07 -11	LS
	690 SMC	08 -10	LS
	690 SMC R	14 -24	LS
	690 Supermoto	07 -07	LS
	690 Supermoto R	08 -09	LS
	790 Duke	18 -20	LS
	890 Duke R	20 -20	LS
	990 Super Duke	04 -13	LS
	990 Super Duke R	09 -13	LS
<b>MAICO</b>			
	250 Motocross/		
	Enduro	99 -01	SI
	500 Motocross/		
	Enduro	99 -99	SI
	500 Supermotard	99 -99	HF
<b>MBP</b>			
M	502 N	23 -23	LS
<b>MOTO-MORINI</b>			
	650 Calibro	24 -24	LS
<b>PRAGA</b>			
ED	250	99 -03	SI
CD	610	99 -03	SI
<b>ROYAL ENFIELD</b>			
	350 Classic	23 -23	LS
	350 Meteor	23 -23	LS
	411 Himalayan	19 -23	HF
	451 Himalayan	24 -24	LS
	500 Bullet	20 -20	LS
	500 Bullet Trials	20 -20	LS
	500 Classic	19 -19	HF
	535 Continental GT	14 -19	LS
	650 Continental GT	20 -23	LS
	650 Interceptor	19 -23	LS
<b>SWM</b>			
	600 Superdual GT		
	Pack	18 -18	LS
	600 Superdual T	18 -20	LS
	600 Superdual X	18 -20	LS
	650 Superdual	15 -18	LS
<b>TM</b>			
	80 Cross	96 -00	RSI
MX	125	96 -00	RSI
	250 E	95 -00	RSI
EN	250 F Enduro	00 -00	SI
MX	300	98 -00	RSI
	320	96 -97	RSI
	400 F	00 -00	RSI
<b>TRIUMPH</b>			
	400 Scrambler X	24 -24	LS
	400 Speed	24 -24	LS
	660 Street Triple S	17 -20	LS
	675 Daytona R Triple	13 -18	LS
	675 Daytona Triple	13 -18	LS



<b>TRIUMPH</b>			
	675 Street Triple	13 -17	LS
	675 Street Triple R	13 -17	LS
	675 Street Triple RX	15 -16	LS
	765 Daytona Moto2	20 -22	LS
	765 Street Triple R	17 -23	LS
	765 Street Triple R		
	Low	17 -23	LS
	765 Street Triple RS	17 -23	LS
	765 Street Triple S	17 -20	LS
	850 Tiger Sport	21 -23	LS
	900 Rally Pro	20 -23	LS
	900 Tiger	20 -23	LS
	900 Tiger GT	20 -23	LS
	900 Tiger GT Low	20 -23	LS
	900 Tiger GT Pro	20 -23	LS
	900 Tiger Rally	20 -23	LS
	1200 Tiger GT	22 -23	LS
	1200 Tiger GT		
	Explorer	22 -23	LS
	1200 Tiger GT Pro	22 -23	LS
	1200 Tiger Rally		
	Explorer	22 -23	LS
	1200 Tiger Rally Pro	22 -23	LS
<b>VERTEMATI</b>			
C	500 Cross	02 -04	RSI
E	501 Enduro	02 -04	SI
S	501 Supermotard	02 -04	HF
<b>VICTORY</b>			
	1200 Octane	17 -17	H.LS
<b>VOGE</b>			
	525 CU	24 -24	LS
	900 DSX	24 -24	LS
DS	900 Valico	23 -23	LS
<b>VOR</b>			
	400 Cross	00 -01	RSI
	400 Enduro	00 -01	SI
EN	400	02 -03	SI
MX	400	02 -02	RSI
SM	400	02 -02	RSI
EN	450	02 -04	SI
MX	450	02 -04	RSI
SM	450	02 -04	RSI
	500 492 Enduro	99 -99	SI
	500 492 Super		
	Motard	00 -01	HF
	500 495 Cross	99 -99	RSI
EN	530	02 -04	SI
MX	530	02 -04	RSI
SM	530	02 -04	RSI
<b>YAMAHA</b>			
WR	125 R, XY	09 -16	HF
TT	600 E,S	96 -01	HF
TT	600 R	98 -07	HF
MT-03	660	06 -13	LS
XT	660 R	04 -11	LS
XT	660 X	04 -13	LS
XT	660 Z Tenere	08 -15	LS
XT	660 Z Tenere ABS	11 -15	LS
XTZ	700 Tenere	19 -24	LS
XTZ	700 Tenere Explore	19 -24	LS
XTZ	700 Tenere Extreme	19 -24	LS
XTZ	700 Tenere World		
	Raid	19 -24	LS
XTZ	700 Tenere World		
	Rally	19 -24	LS

STREET  
AMERICAN  
SCOOTER

HF • HS • LS  
H.HF • H.CT • H.HS • H.LS  
HF • CT • MS

RACING  
OFF ROAD  
ATV

RST • DC • DCC • DS-1 • DS-2 • RQ  
SI • RSI • CS  
ATS • SI • RSI • PSI

Drawings 1:1

Available compounds

HF • LS • RQ • CS • SI • RSI • H.HF • H.CT • H.LS

SBS 675

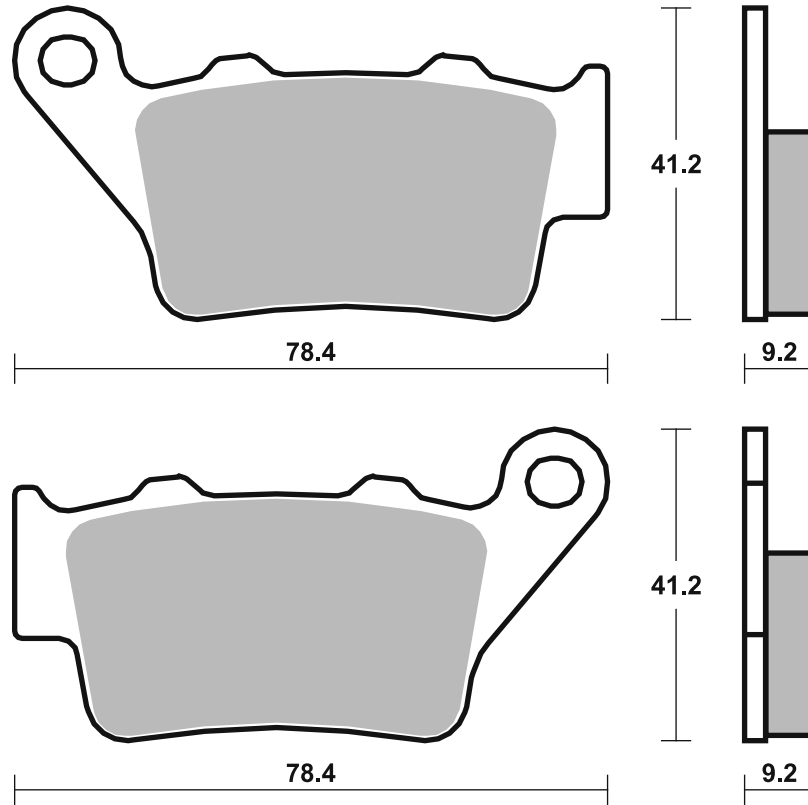

Applications

**SBS 675** Recommended compound



<b>ZERO</b>			
DS	ZF11.4	14 - 14	<b>LS</b>
DS	ZF12.5	15 - 15	<b>LS</b>
DS	ZF13.0	16 - 17	<b>LS</b>
DS	ZF8.5	14 - 14	<b>LS</b>
DS	ZF9.4	15 - 15	<b>LS</b>
DS	ZF9.8	16 - 17	<b>LS</b>
DSR	ZF13.0	16 - 17	<b>LS</b>
DSRBF	ZF14.4	19 - 21	<b>LS</b>
FX	ZF2.8	14 - 15	<b>LS</b>
FX	ZF3.3	16 - 17	<b>LS</b>
FX	ZF5.7	14 - 15	<b>LS</b>
FX	ZF6.5	16 - 17	<b>LS</b>
FXE	ZF7.2	21 - 22	<b>LS</b>
FXS	ZF3.3	16 - 17	<b>LS</b>
FXS	ZF3.6	16 - 22	<b>LS</b>
FXS	ZF6.5	16 - 17	<b>LS</b>
S	ZF11.4	14 - 14	<b>LS</b>
S	ZF12.5	15 - 15	<b>LS</b>
S	ZF13.0	16 - 17	<b>LS</b>
S	ZF14.4	24 - 24	<b>LS</b>
S	ZF8.5	14 - 14	<b>LS</b>
S	ZF9.4	15 - 15	<b>LS</b>
S	ZF9.8	16 - 17	<b>LS</b>
SR	ZF11.4	14 - 14	<b>LS</b>
SR	ZF12.5	15 - 15	<b>LS</b>
SR	ZF13.0	16 - 17	<b>LS</b>



<b>ZERO</b>			
SR	ZF15.6	24 - 24	<b>LS</b>
SR	ZF17.3	24 - 24	<b>LS</b>
SR/F	ZF14.4	19 - 21	<b>LS</b>
SR/F	ZF17.3	24 - 24	<b>LS</b>
SR/S	ZF14.4	19 - 22	<b>LS</b>

**SBS 676** Recommended compound



<b>BRACING</b>			
Front Harley Davidson			
<b>BUELL</b>			
M2	1200 Cyclone	98 - 02	<b>HS</b>
S1	1200 Lightning	98 - 02	<b>HS</b>
S1	1200 Whitelightning	98 - 02	<b>HS</b>
S3	1200 Thunderbolt	98 - 02	<b>HS</b>
X1	1200 Lightning	01 - 02	<b>HS</b>
<b>HHI</b>			
6 Piston Caliper			
<b>HONDA</b>			
CB	1300 SF	98 - 00	<b>HS</b>



<b>KAWASAKI</b>			
ZX-7RR	750 Ninja	96 - 02	<b>HS</b>
<b>MV AGUSTA</b>			
	750 Brutale,		
	Brutale S	01 - 05	<b>HS</b>
F4	750	99 - 02	<b>HS</b>
F4	750 SPR	01 - 03	<b>HS</b>
	910 Brutale	06 - 08	<b>HS</b>
	910 Brutale S	06 - 08	<b>HS</b>
F4	1000 Mamba	04 - 06	<b>HS</b>
F4	1000 S	04 - 06	<b>HS</b>
F4	1000 Tamburini	04 - 06	<b>HS</b>



<b>REBUFFINI</b>			
Kalipso			
Kerio			
RR108			

**SBS 678** Recommended compound



<b>HHI</b>			
4 Piston Caliper			
<b>INDIAN</b>			
	Chief	01 - 08	<b>H.HS H.LS</b>
	Scout	01 - 08	<b>H.HS H.LS</b>
<b>MOTOR FACTORY</b>			
4 Piston Caliper front/rear			
<b>PERFORMANCE MACHINE</b>			
125 X 4R			
125 X 4RSPH			
137 X 4B			
4 Piston Vintage Caliper			

Brake Pad 1:1 Drawings, Compounds, Fitments

STREET  
AMERICAN  
SCOOTER

HF • HS • LS  
H.HF • H.CT • H.HS • H.LS  
HF • CT • MS

RACING  
OFF ROAD  
ATV

RST • DC • DCC • DS-1 • DS-2 • RQ  
SI • RSI • CS  
ATS • SI • RSI • PSI

Drawings 1:1

Available compounds

HF • LS • RQ • CS • SI • RSI • H.HF • H.CT • H.LS

SBS 675

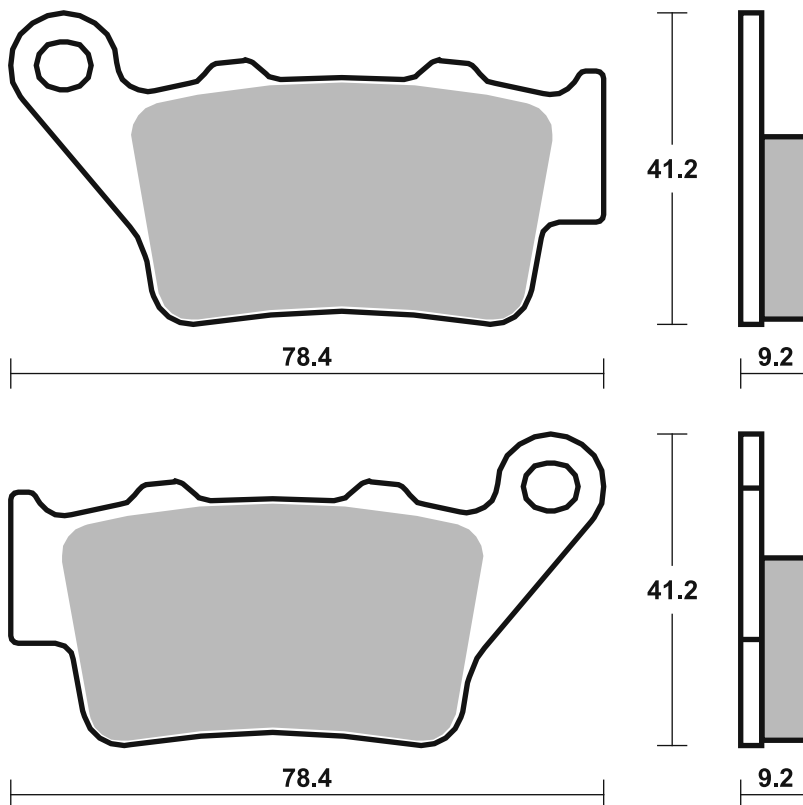

Available compounds

HF • HS • DC • RST • H.HF • H.CT • H.HS

SBS 676

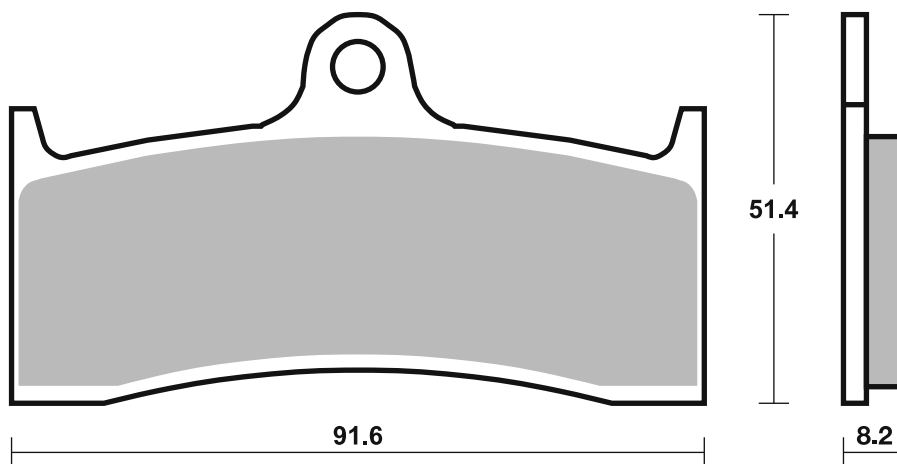

Available compounds

HF • HS • LS • DC • H.HF • H.CT • H.HS • H.LS

SBS 678

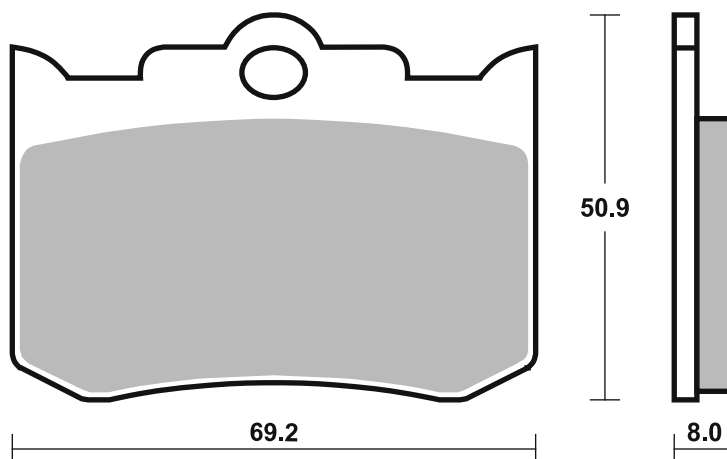

Dimensions in mm / Dimensions en mm  
1" = 25.4 mm, 1 mm = 0.04"

## Applications

### SBS 679 Recommended compound



#### HARLEY DAVIDSON

FXB	Series	74 - 77	H.HF
FXE	Series	74 - 77	H.HF
XL	Series	74 - 77	H.HF

### SBS 680 Recommended compound



#### CAGIVA

	50 Prima	93 - 94	HF
	80 Prima	92 - 92	HF

### SBS 681 Recommended compound



#### APRILIA

	650 Pegaso	92 - 94	HF

#### MZ

	125 SM, SX	99 - 01	HF
	660 (MUZ) Baghira	96 - 00	HF
	660 (MUZ) Black Panther	00 - 06	HF
	660 (MUZ) Mastiff	96 - 06	HF
	660 (MUZ) Street Moto	00 - 06	HF
	660 (MUZ) Super Moto	07 - 07	HF

STREET  
AMERICAN  
SCOOTER

HF • HS • LS  
H.HF • H.CT • H.HS • H.LS  
HF • CT • MS

RACING  
OFF ROAD  
ATV

RST • DC • DCC • DS-1 • DS-2 • RQ  
SI • RSI • CS  
ATS • SI • RSI • PSI

Drawings 1:1

Available compounds

H.HF

SBS 679

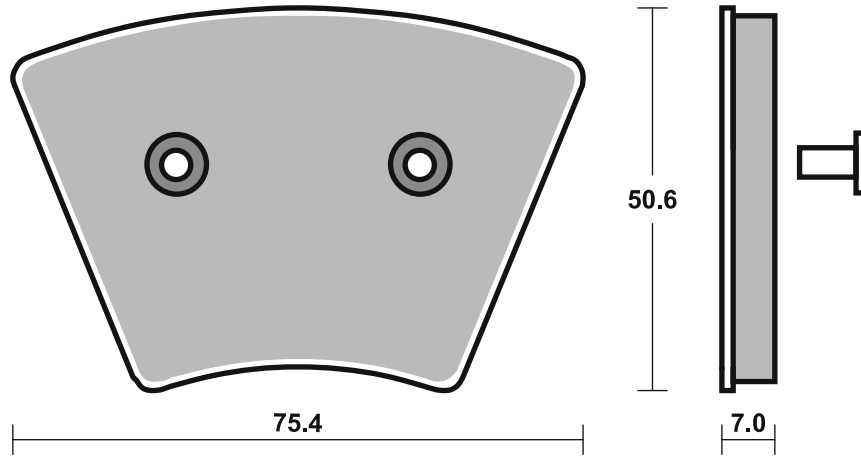

Available compounds

HF

SBS 680

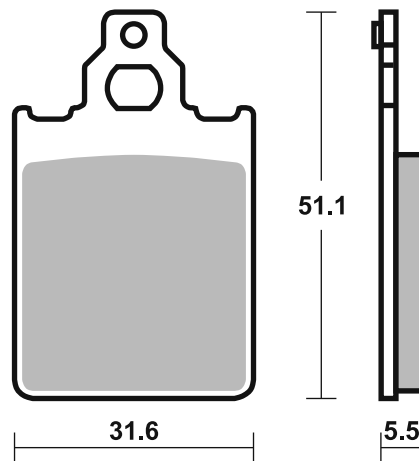

Available compounds

HF

SBS 681

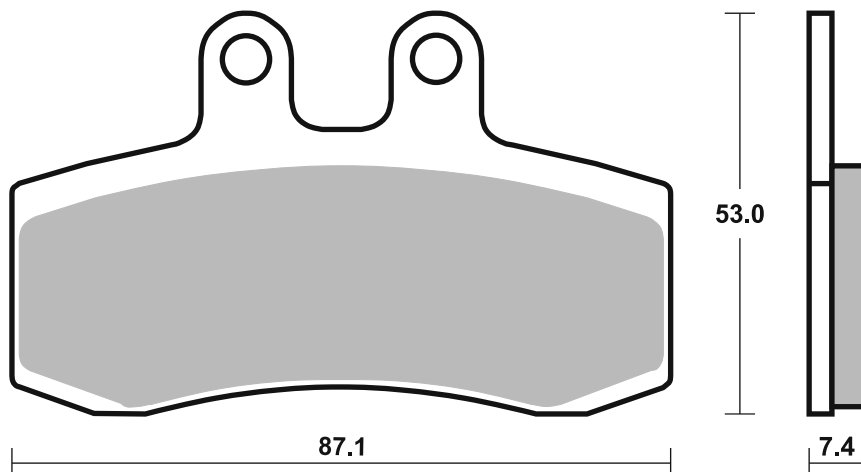

**SBS 682**

**Recommended compound**



**YAMAHA**

GTS	1000	93 - 99	HF	

**SBS 683**

**Recommended compound**



**PERFORMANCE MACHINE**

112 X 6RSB				
112 X 6SSB				
125 X 6QC				

**TRIUMPH**

900 Daytona Super III	94 - 98	HS		
-----------------------	---------	----	--	--

**YAMAHA**

YZF	750 R, SP	93 - 97	HS	
FZR	1000	94 - 95	HS	

Brake Pad 1:1 Drawings, Compounds, Fitments



STREET  
AMERICAN  
SCOOTER

HF • HS • LS  
H.HF • H.CT • H.HS • H.LS  
HF • CT • MS

RACING  
OFF ROAD  
ATV

RST • DC • DCC • DS-1 • DS-2 • RQ  
SI • RSI • CS  
ATS • SI • RSI • PSI

Drawings 1:1

Available compounds

HF

SBS 682

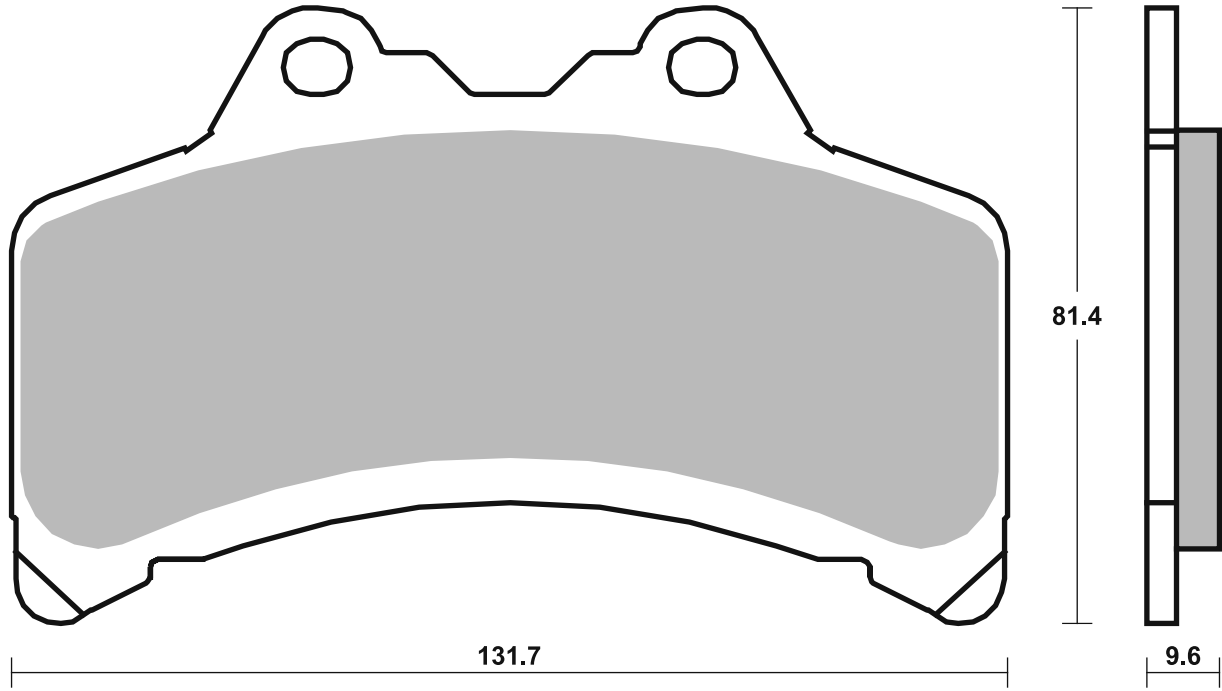

Available compounds

HF • HS • RST • H.HF • H.CT • H.HS

SBS 683

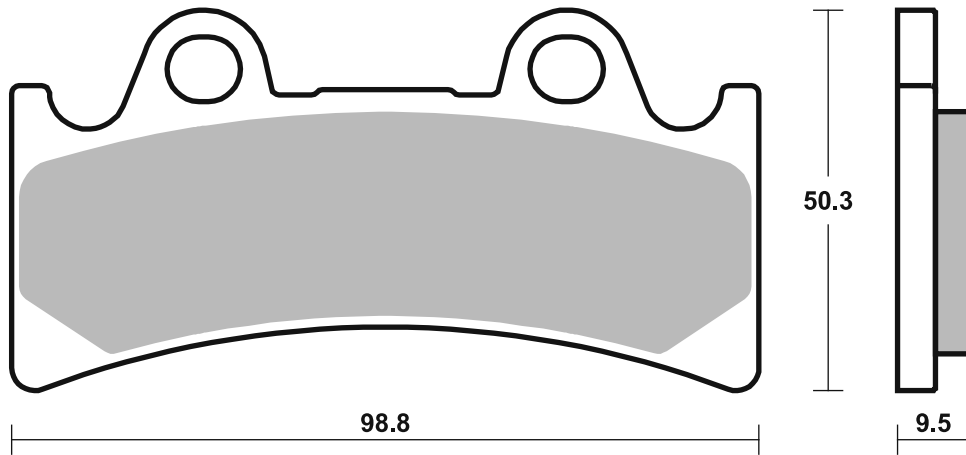



STREET  
AMERICAN  
SCOOTER

HF • HS • LS  
H.HF • H.CT • H.HS • H.LS  
HF • CT • MS

RACING  
OFF ROAD  
ATV

RST • DC • DCC • DS-1 • DS-2 • RQ  
SI • RSI • CS  
ATS • SI • RSI • PSI

Drawings 1:1

Available compounds

HF

SBS 684

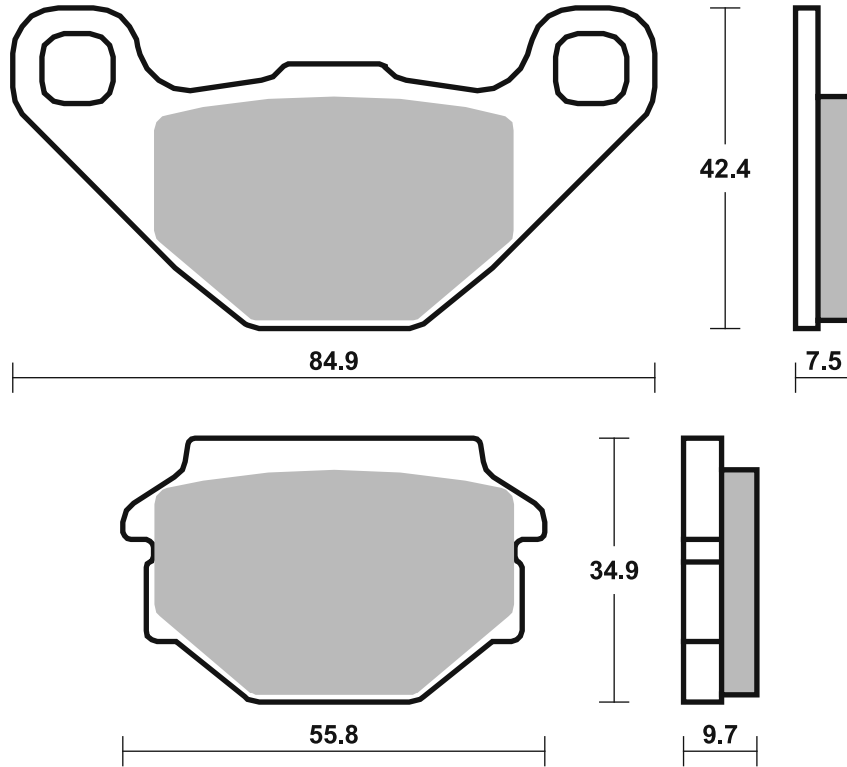

Available compounds

HF • HS • LS

SBS 685

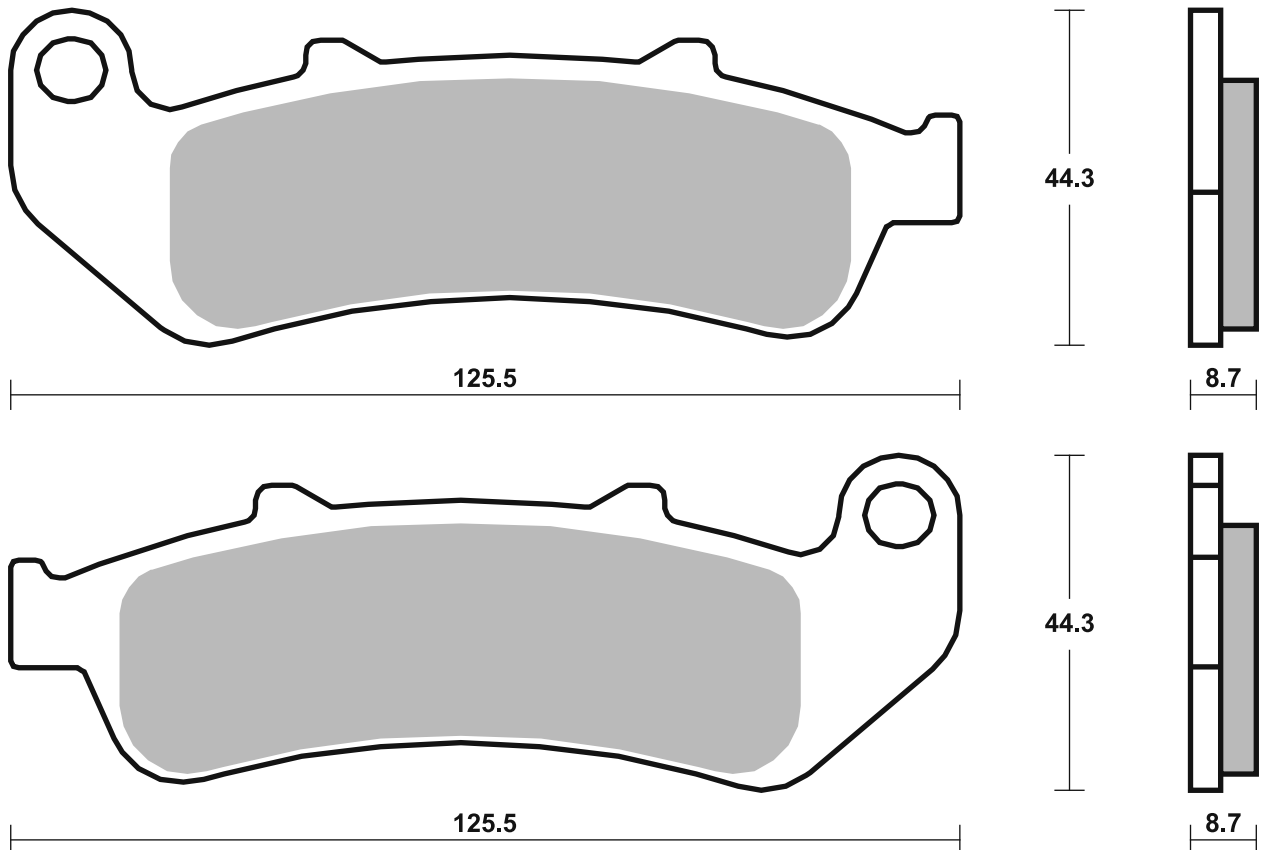

Dimensions in mm / Dimensions en mm  
1" = 25.4 mm, 1 mm = 0.04"

Brake Pad 1:1 Drawings,  
Compounds, Fitsments

## Applications

### SBS 686

### Recommended compound



#### JAYBRAKE

4 Piston Caliper A4 P/L

4 Piston J-Four Caliper

#### KAWASAKI

ZX-6R 600 Ninja 98 - 01 **HS**

ZX-6R 636 Ninja 02 - 02 **HS**

ZX-7R 750 Ninja 96 - 03 **HS**

ZX-9R 900 Ninja 96 - 01 **HS**

ZRX 1100 96 - 00 **HS**

ZRX 1200 01 - 04 **HS**

ZRX 1200 R 01 - 08 **HS**

ZRX 1200 S 01 - 07 **HS**

ZX-12R 1200 Ninja 00 - 03 **HS**

VN 1500 Mean Streak 02 - 03 **HS**

VN 1600 Mean Streak 04 - 04 **HS**

#### SUZUKI

GSX-R 750 94 - 99 **HS**

GSX-R 1000 01 - 02 **HS**

TL 1000 RW 98 - 02 **HS**

GSX-R 1100 93 - 97 **HS**

GSF 1200 Bandit 01 - 05 **HS**

GSF 1200 S Bandit 01 - 05 **HS**

GSX-R 1300 Hayabusa 99 - 07 **HS**

GSX 1400 02 - 07 **HS**

VZ 1600 Marauder 04 - 04 **HS**

### SBS 687

### Recommended compound



#### KAWASAKI

400 Ninja R 11 - 11 **LS**

ZR 400 Zephyr 97 - 01 **LS**

ZZR 500 (Austria) 93 - 98 **LS**

ZR 550 Zephyr 93 - 99 **LS**

ZR 550 Zephyr (D) from

VIN B024010- 93 - 01 **LS**

ZX-6R 600 (Ninja ZX6) 93 - 97 **LS**

ZX-6R 600 (Ninja ZX6R) 95 - 97 **LS**

ZX-6R 600 Ninja 98 - 01 **LS**

ZX-6R 600 Ninja 07 - 17 **LS**

ZX-6RR 600 Ninja 03 - 06 **LS**

ZZR 600 93 - 07 **LS**

ZX-6R 636 Ninja 02 - 06 **LS**

ER-6f 650 06 - 16 **LS**

ER-6n 650 06 - 16 **LS**

KLE 650 Versys 07 - 14 **LS**

KLE 650 Versys ABS 07 - 14 **LS**

Z 750 04 - 06 **LS**

Z 750 S 05 - 06 **LS**

ZX-9R 900 Ninja 94 - 01 **LS**

1000 Ninja SX 20 - 24 **LS**

Z 1000 03 - 06 **LS**

Z 1000 10 - 16 **LS**

Z 1000 ABS 15 - 19 **LS**

Z 1000 R 17 - 18 **LS**

Z 1000 SE 14 - 16 **LS**

Z 1000 SX 11 - 23 **LS**

ZX-10R 1000 Ninja 04 - 10 **LS**

GPZ 1100 (ZX 1100) 95 - 99 **LS**

GPZ 1100 ABS, Horizont 97 - 99 **LS**

STREET  
AMERICAN  
SCOOTER

HF • HS • LS  
H.HF • H.CT • H.HS • H.LS  
HF • CT • MS

RACING  
OFF ROAD  
ATV

RST • DC • DCC • DS-1 • DS-2 • RQ  
SI • RSI • CS  
ATS • SI • RSI • PSI

Drawings 1:1

Available compounds

HF • HS • DC • RST • H.HF • H.CT • H.HS

SBS 686

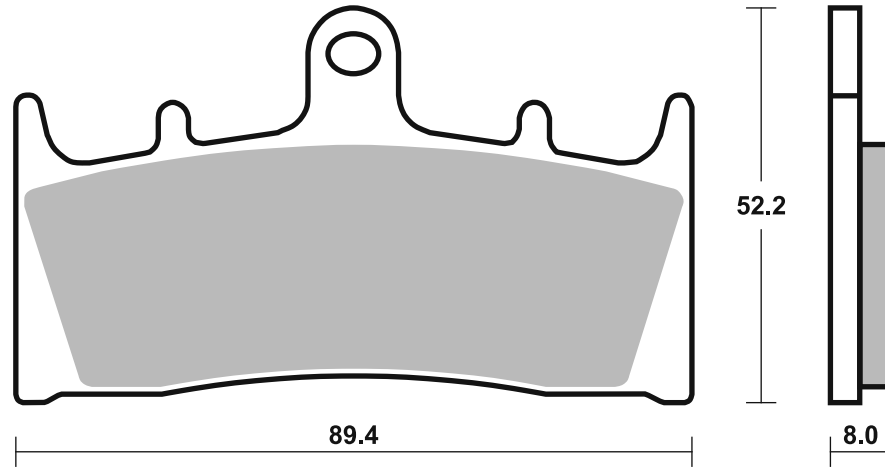

HF / HS - Th. 8.0  
RST / DC - Th. 9.5

Available compounds

HF • LS • RQ

SBS 687

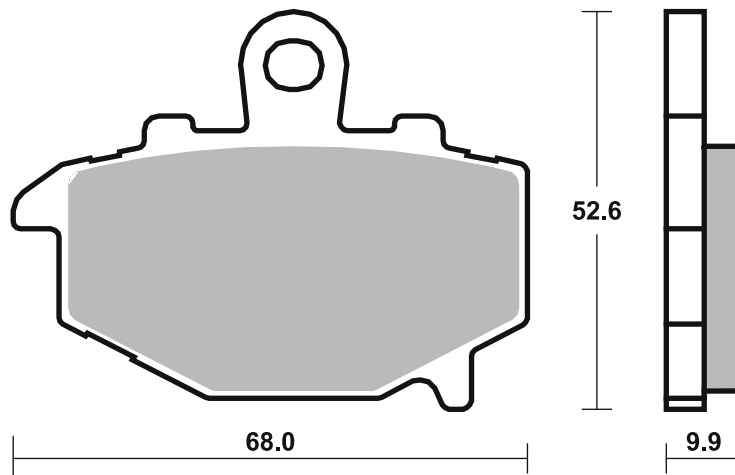
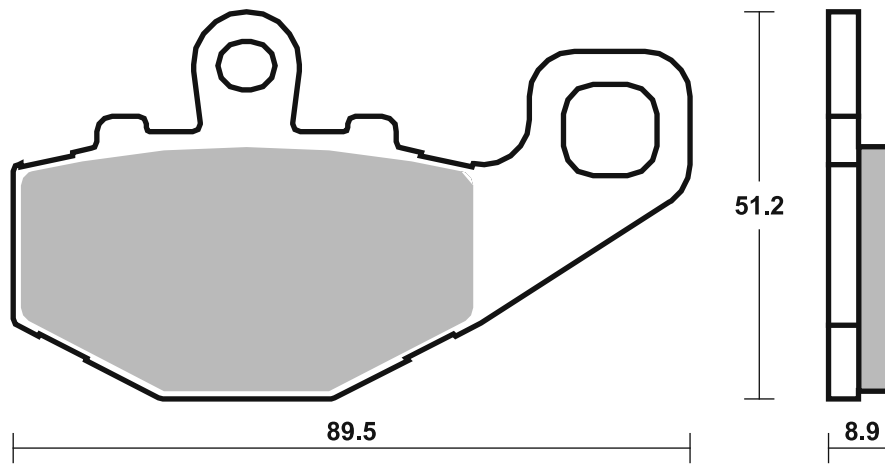



STREET  
AMERICAN  
SCOOTER

HF • HS • LS  
H.HF • H.CT • H.HS • H.LS  
HF • CT • MS

RACING  
OFF ROAD  
ATV

RST • DC • DCC • DS-1 • DS-2 • RQ  
SI • RSI • CS  
ATS • SI • RSI • PSI

Available compounds

HF • DC

SBS 688

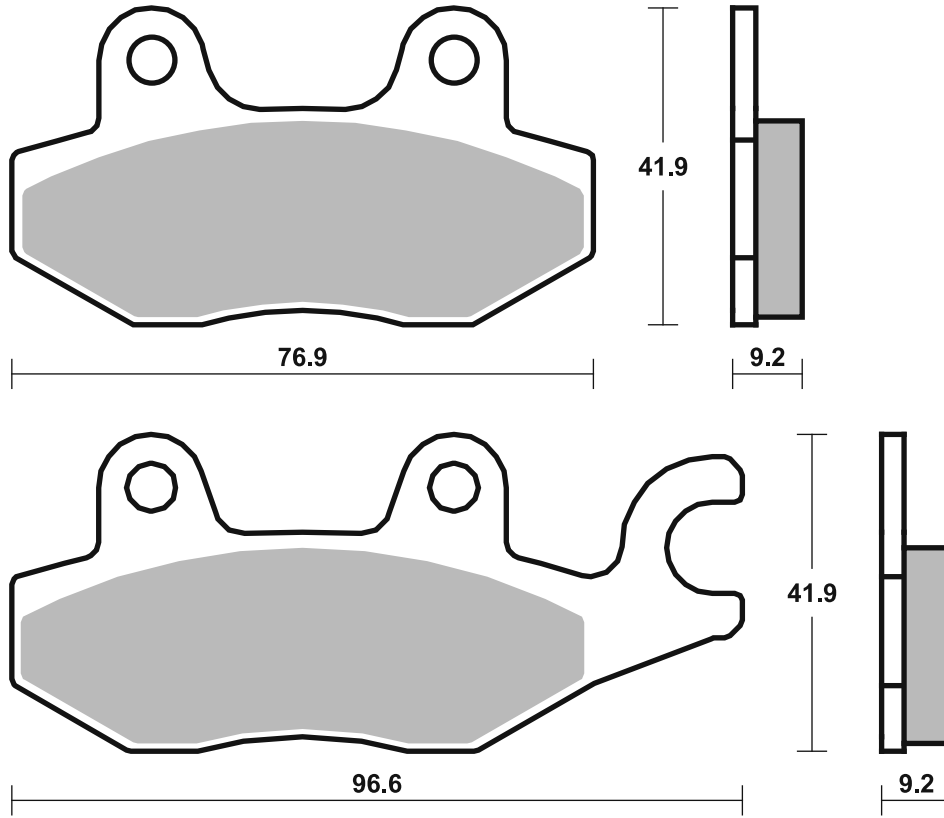

Available compounds

HF

SBS 689

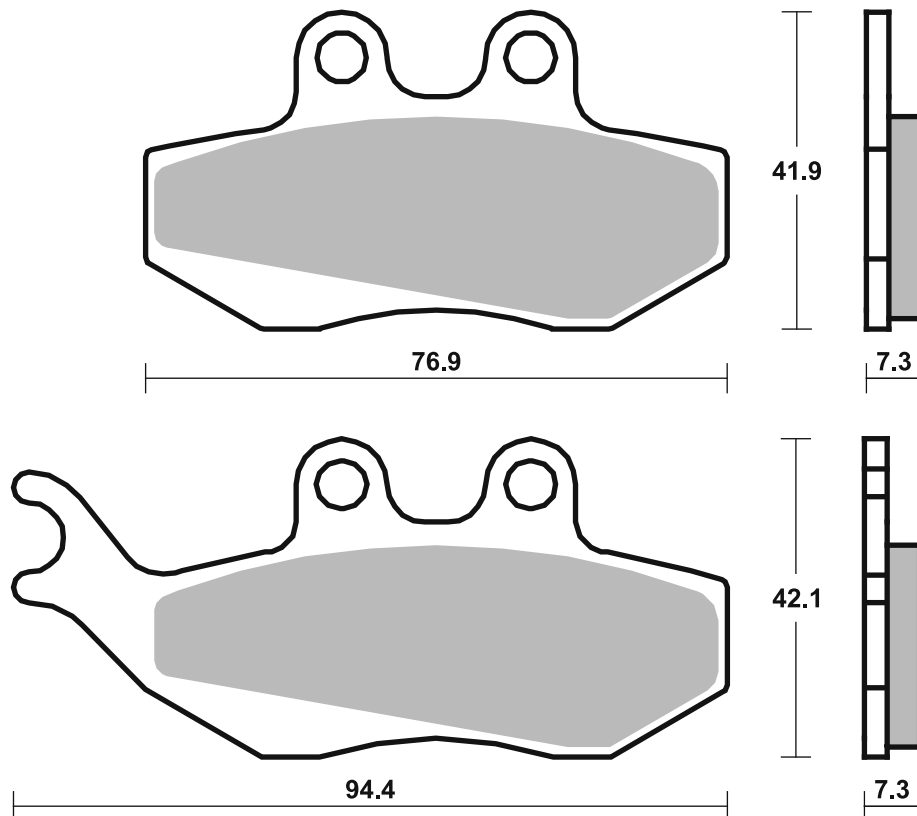

## Applications

### SBS 690

### Recommended compound



#### JINCHENG

JC	125 2B	97 - 97	HF
----	--------	---------	----

#### MOTOR UNION

JC	125 2B Deer	98 - 99	HF
----	-------------	---------	----

### SBS 691

### Recommended compound



#### BAOXIN

BX	125 L	97 - 97	HF
----	-------	---------	----

#### JIANSHE

JS	125 3	02 - 02	HF
----	-------	---------	----

#### JINCHENG

JC	150 T-D	06 - 09	HF
----	---------	---------	----

#### KEEWAY

	250 Supershadow	06 - 09	HF
--	-----------------	---------	----

#### LONCIN

LX	150 6	02 - 02	HF
----	-------	---------	----

#### MZ

	1000 (MUZ) S	01 - 02	HF
--	--------------	---------	----

#### QUINGOI

QM	125 2V	02 - 05	HF
----	--------	---------	----

#### YAMAHA

SR	125	97 - 02	HF
----	-----	---------	----

TDR	125 R	93 - 03	HS
-----	-------	---------	----

TZR	125	93 - 93	HF
-----	-----	---------	----

XV	125 Virago	97 - 00	HF
----	------------	---------	----

XVS	125 Drag Star	00 - 06	HF
-----	---------------	---------	----

XV	250 Route 66	95 - 97	HF
----	--------------	---------	----

XV	250 S Virago	95 - 07	HS
----	--------------	---------	----

XVS	250 Drag Star	01 - 04	HF
-----	---------------	---------	----

FZ6	600	04 - 08	HS
-----	-----	---------	----

FZ6	600 Fazer	04 - 08	HS
-----	-----------	---------	----



#### YAMAHA

FZ6R	600	09 - 14	HS
------	-----	---------	----

XJ	600 N	98 - 03	HS
----	-------	---------	----

XJ	600 S Diversion	98 - 03	HS
----	-----------------	---------	----

XJ6	600 Diversion	09 - 15	HS
-----	---------------	---------	----

XJ6-F	600	09 - 15	HS
-------	-----	---------	----

XJ6-N	600	09 - 15	HS
-------	-----	---------	----

XJ6-S	600	09 - 15	HS
-------	-----	---------	----

MT-03	660	06 - 13	HS
-------	-----	---------	----

XV	1100 Virago	99 - 99	HS
----	-------------	---------	----

XVS	1100 A Drag Star		
-----	------------------	--	--

	Classic	00 - 06	HS
--	---------	---------	----

XVS	1100 Drag Star	99 - 06	HS
-----	----------------	---------	----

XVS	1300 A Midnight Star	07 - 11	HS
-----	----------------------	---------	----

XVS	1300 Custom	14 - 16	HS
-----	-------------	---------	----



STREET  
AMERICAN  
SCOOTER

HF • HS • LS  
H.HF • H.CT • H.HS • H.LS  
HF • CT • MS

RACING  
OFF ROAD  
ATV

RST • DC • DCC • DS-1 • DS-2 • RQ  
SI • RSI • CS  
ATS • SI • RSI • PSI

Drawings 1:1

Available compounds

HF

SBS 690

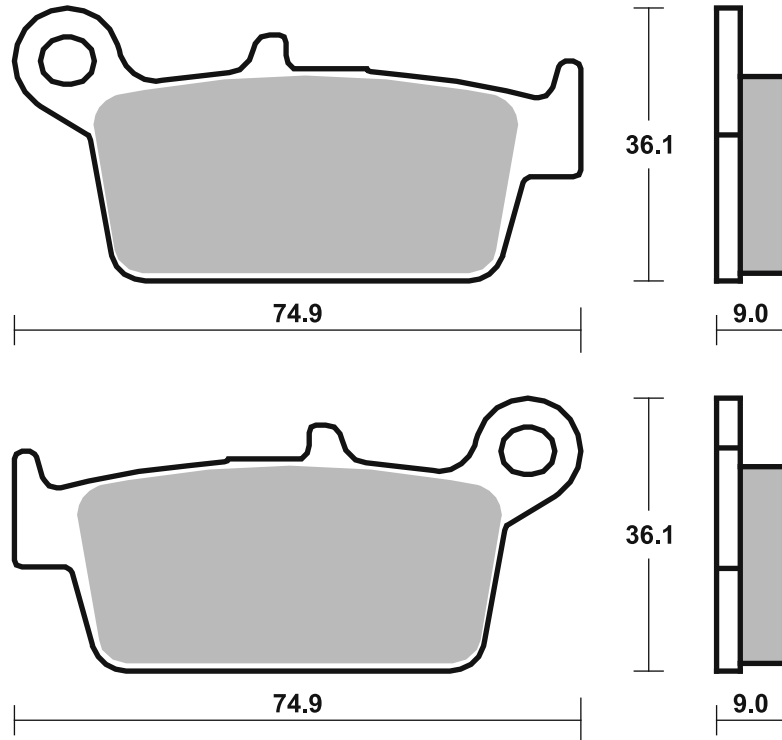

Available compounds

HF • HS

SBS 691

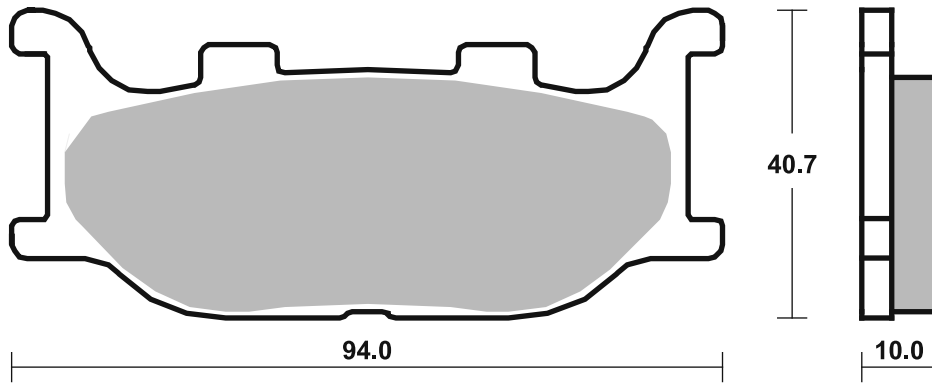

## Applications

### SBS 692

### Recommended compound



<b>APRILIA</b>			
	125 Pegaso	90 -91	<b>HF</b>
	125 Tuareg Wind	90 -94	<b>HF</b>
RX	125	91 -91	<b>HF</b>
RX	125	97 -99	<b>HF</b>
	600 Tuareg	88 -89	<b>HF</b>
	600 Tuareg Wind	90 -94	<b>HF</b>
	650 Moto	95 -03	<b>HF</b>
	650 Pegaso	95 -00	<b>HF</b>
	650 Starck	96 -01	<b>HF</b>
<b>BUELL</b>			
	all models	94 -97	<b>HF</b>
RS	1200	12 -12	<b>HF</b>
<b>CAGIVA</b>			
	125 Cross	86 -86	<b>SI</b>
	125 W 8	96 -01	<b>HF</b>
WMX	125	89 -90	<b>SI</b>
WMX	250	89 -90	<b>SI</b>
	600 W 16	95 -97	<b>HF</b>
<b>FANTIC</b>			
	50 ,1 Raider	87 -87	<b>HF</b>
	50 Strada	83 -83	<b>HF</b>
<b>HUSQVARNA</b>			
CR/WR	125	91 -91	<b>SI</b>
WR	240	87 -91	<b>SI</b>
CR	250	91 -91	<b>SI</b>
WR	260	90 -93	<b>SI</b>
TC	610 Cross	91 -91	<b>SI</b>
TE	610	91 -95	<b>SI</b>



<b>KRAM-IT</b>			
	50 Scrambler	90 -90	<b>HF</b>
ER	125	89 -93	<b>SI</b>
MC	250	89 -89	<b>SI</b>
ER	300	89 -89	<b>SI</b>
<b>KTM</b>			
MX	125	89 -90	<b>SI</b>
MX	125	92 -93	<b>SI</b>
MX	250	89 -90	<b>SI</b>
MX	250	92 -93	<b>SI</b>
MX	500	89 -93	<b>SI</b>
<b>YAMAHA</b>			
TDR	125 (Italy)	90 -93	<b>SI</b>

### SBS 694

### Recommended compound



<b>AJP</b>			
PR5	250 Enduro	09 -09	<b>SI</b>
PR5	250 Supermotard	09 -09	<b>SI</b>
<b>APRILIA</b>			
MXV	450	09 -13	<b>RSI</b>
RXV	450	06 -13	<b>SI</b>
RXV	550	06 -13	<b>SI</b>
<b>BETA</b>			
RR	125	18 -19	<b>SI</b>
RR	250	05 -09	<b>SI</b>
	300 Crosstrainer	15 -15	<b>SI</b>
RR	300	13 -19	<b>SI</b>
RR	350 Efi	15 -15	<b>SI</b>
RR	350 Efi Racing	15 -15	<b>SI</b>
RR	350 Enduro	12 -14	<b>SI</b>
RR	390	15 -19	<b>SI</b>
RR	400 Enduro	05 -05	<b>SI</b>
RR	430	15 -19	<b>SI</b>
RR	430 Racing	15 -19	<b>SI</b>
	450 RX	24 -24	<b>RSI</b>
RR	450 Cross		
	Country	12 -12	<b>SI</b>
RR	450 Enduro	05 -07	<b>SI</b>
RR	480	15 -19	<b>SI</b>
RR	480 Racing	15 -19	<b>SI</b>
RR	498 Enduro	12 -14	<b>SI</b>
RR	525 Enduro	05 -13	<b>SI</b>



<b>BIMOTA</b>			
BBX	300 Enduro	12 -12	<b>SI</b>
BX	450	23 -23	<b>SI</b>
BBX	508 Enduro	12 -12	<b>SI</b>
<b>BRACING</b>			
	Front Cross		
<b>CANNONDALE</b>			
MX	400	00 -03	<b>RSI</b>
C	440 R	03 -03	<b>RSI</b>
E	440 ,A, R	03 -03	<b>RSI</b>
X	440	03 -03	<b>RSI</b>
<b>CPI</b>			
	125 Sahel	02 -02	<b>HF</b>
<b>FANTIC</b>			
	50 Regolarna		
	Competizione	08 -09	<b>HF</b>
MX	50 Regolarna		
	Competizione	08 -08	<b>RSI</b>
MX	65 Regolarna		
	Competizione	08 -08	<b>RSI</b>
	80 Regolarna		
	Competizione	08 -08	<b>HF</b>
MX	85 Regolarna		
	Competizione	08 -08	<b>RSI</b>
	125 Caballero		
	Enduro 2T	12 -10	<b>HF</b>



<b>FANTIC</b>			
	125 Caballero		
	Motard 2T	10 -10	<b>HF</b>
	125 Regolarna		
	Competizione	08 -08	<b>HF</b>
<b>GASGAS</b>			
	125 Enducross	93 -93	<b>SI</b>
EC	125	00 -06	<b>SI</b>
MC	125	03 -13	<b>RSI</b>
EC	200	00 -09	<b>SI</b>
EC	200	17 -17	<b>SI</b>
EC	200 Hobby	07 -16	<b>SI</b>
XC	200	18 -19	<b>SI</b>
EC	250	00 -20	<b>SI</b>
EC	250 Enduro GP 18	18 -19	<b>SI</b>
EC	250 fse	02 -11	<b>SI</b>
MC	250	00 -13	<b>RSI</b>
XC	250	17 -19	<b>SI</b>
EC	300	00 -20	<b>SI</b>
EC	300 Enduro GP 18	18 -19	<b>SI</b>
XC	300	18 -19	<b>SI</b>
	400 Pampera	06 -09	<b>SI</b>
EC	400 fse	02 -02	<b>SI</b>
EC	450 fse	03 -15	<b>SI</b>
EC	450 FSR	07 -16	<b>SI</b>
EC	515 fsr	08 -16	<b>SI</b>
<b>HM</b>			
	125 Supermotard	00 -02	<b>HF</b>

STREET  
AMERICAN  
SCOOTER

HF • HS • LS  
H.HF • H.CT • H.HS • H.LS  
HF • CT • MS

RACING  
OFF ROAD  
ATV

RST • DC • DCC • DS-1 • DS-2 • RQ  
SI • RSI • CS  
ATS • SI • RSI • PSI

Drawings 1:1

Available compounds

HF • SI • RSI

SBS 692

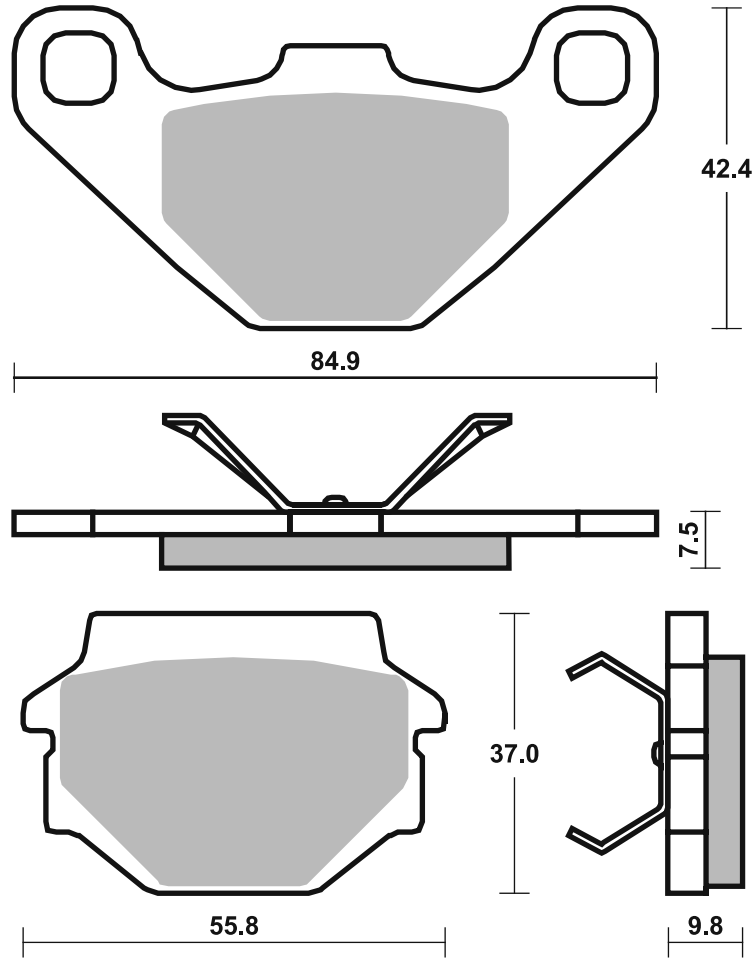

Available compounds

HF • HS • CS • SI • RSI

SBS 694

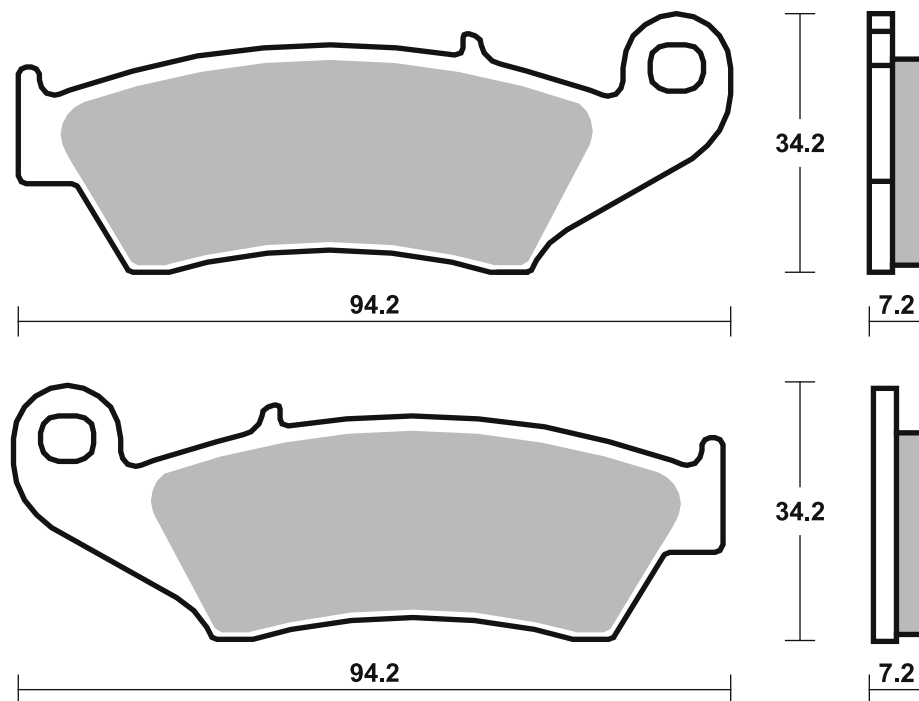



<b>HM</b>			
CR	125 Supermotard	04 - 06	<b>RSI</b>
CRE	125 Enduro	95 - 06	<b>SI</b>
CRE	125 Supermotard	03 - 03	<b>HF</b>
	250 Supermotard	00 - 02	<b>HF</b>
CRE	250 Enduro	95 - 03	<b>SI</b>
CRE	250 F Enduro	04 - 13	<b>SI</b>
CRE	250 Supermotard	03 - 03	<b>HF</b>
CRE	250 Supermotard	04 - 07	<b>RSI</b>
CRE	250 X Enduro	04 - 13	<b>SI</b>
CRF	250 Supermotard	04 - 06	<b>RSI</b>
CRE	450 F Enduro	02 - 13	<b>SI</b>
CRE	450 X Enduro	04 - 13	<b>SI</b>
CRF	450 Supermotard	02 - 06	<b>RSI</b>

**HONDA**

CR	125 R	95 - 07	<b>RSI</b>
CRE	125	02 - 07	<b>SI</b>
CRF	125 F	14 - 24	<b>SI</b>
XLR	125 R	98 - 01	<b>HF</b>
XR	125 L	03 - 07	<b>HF</b>
CRF	150 F	03 - 06	<b>SI</b>
CTX	200	04 - 06	<b>SI</b>
CRF	230	04 - 09	<b>SI</b>
CRF	230 L	08 - 10	<b>SI</b>
CRF	230 M	09 - 12	<b>SI</b>
SL	230	97 - 01	<b>HF</b>
CR	250 R	95 - 07	<b>RSI</b>
CRE	250	02 - 07	<b>SI</b>
CRE	250 F	04 - 04	<b>SI</b>
CRF	250 F	19 - 24	<b>SI</b>
CRF	250 R	04 - 24	<b>RSI</b>
CRF	250 RX	19 - 24	<b>SI</b>
CRF	250 X	04 - 19	<b>SI</b>
XLR	250 R SPL	94 - 94	<b>SI</b>
XR	250 L	93 - 97	<b>HF</b>
XR	250 S	96 - 00	<b>HF</b>
XR	300	10 - 12	<b>HF</b>
XR	400 R	96 - 04	<b>SI</b>
XR	400 Supermotard	00 - 03	<b>RSI</b>
XR	440 R	00 - 03	<b>SI</b>
CRE	450 F	02 - 06	<b>SI</b>
CRF	450 L	19 - 21	<b>RSI</b>
CRF	450 R	02 - 24	<b>RSI</b>
CRF	450 R-S	22 - 24	<b>RSI</b>
CRF	450 RWE	19 - 24	<b>RSI</b>
CRF	450 RX	17 - 24	<b>SI</b>
CRF	450 X	05 - 24	<b>SI</b>
TRX	450 R	04 - 09	<b>SI</b>
CR	500 R	95 - 01	<b>RSI</b>
XL	600 V, Transalpino	97 - 99	<b>HS</b>
XR	600 R	93 - 00	<b>SI</b>
XL	650 V Transalp	00 - 07	<b>HS</b>
XR	650 L	93 - 18	<b>HF</b>
XR	650 R	00 - 11	<b>SI</b>
TRX	700 XX	08 - 12	<b>SI</b>
XL	700 Transalp	08 - 11	<b>HS</b>
XRV	750 Africa Twin	93 - 03	<b>HS</b>

**KAWASAKI**

KX	125	94 - 08	<b>RSI</b>
KDX	200	94 - 99	<b>SI</b>
KDX	220 R	97 - 05	<b>SI</b>
KLX	250	93 - 96	<b>SI</b>
KLX	250	98 - 07	<b>SI</b>
KX	250	94 - 08	<b>RSI</b>
KX	250	19 - 24	<b>RSI</b>
KX	250 F	04 - 18	<b>RSI</b>
KX	250 X	21 - 24	<b>SI</b>
KLX	300	96 - 07	<b>HF</b>
KLX	300 R	97 - 07	<b>SI</b>



<b>KAWASAKI</b>			
KLX	400 R	03 - 04	<b>SI</b>
KLX	400 SR	03 - 04	<b>HF</b>
KLX	450 R	07 - 24	<b>SI</b>
KX	450	19 - 23	<b>RSI</b>
KX	450 F	06 - 18	<b>RSI</b>
KX	450 X	21 - 23	<b>SI</b>
KX	500	94 - 04	<b>RSI</b>
KLX	650	93 - 96	<b>SI</b>
KLX	650 R	93 - 95	<b>SI</b>
KLX	650 R D1	96 - 96	<b>SI</b>

**KOVE**

MX	250	24 - 24	<b>RSI</b>
MX	250 Enduro	24 - 24	<b>SI</b>
MX	250 Off Road	23 - 23	<b>RSI</b>
	450 Rally	23 - 23	<b>SI</b>
MX	450	24 - 24	<b>RSI</b>

**SUZUKI**

DR	125 SM	08 - 12	<b>HF</b>
RM	125	96 - 09	<b>RSI</b>
DR-Z	250	01 - 07	<b>SI</b>
RM	250	96 - 09	<b>RSI</b>
RMX	250	96 - 98	<b>RSI</b>
RMX	250 X-K1	99 - 99	<b>SI</b>
RM-Z	250	04 - 24	<b>RSI</b>
DR	350 V, W, X	97 - 99	<b>SI</b>
DR-Z	400 S/E	00 - 23	<b>HF</b>
DR-Z	400 SM	05 - 24	<b>RSI</b>
RMX	450 Z	10 - 18	<b>SI</b>
RM-Z	450	05 - 24	<b>RSI</b>
DR	650 SE T-W	96 - 99	<b>HF</b>

**YAMAHA**

WR	125	98 - 02	<b>SI</b>
YZ	125	98 - 07	<b>RSI</b>
WR	250	98 - 02	<b>SI</b>
WR	250 F	01 - 13	<b>SI</b>
WR	250 F Efi	15 - 17	<b>SI</b>
WR	250 R	08 - 20	<b>HS</b>
YZ	250	98 - 07	<b>RSI</b>
YZ	250 F	01 - 06	<b>RSI</b>
WR	400 F	98 - 00	<b>SI</b>
YZ	400 F	98 - 99	<b>RSI</b>
WR	426 F	01 - 02	<b>SI</b>
YZ	426 F	00 - 02	<b>RSI</b>
WR	450 F	03 - 15	<b>SI</b>
YZ	450 F	03 - 07	<b>RSI</b>

**ZERO**

DS	ZF11.4	13 - 14	<b>HS</b>
DS	ZF8.5	13 - 14	<b>HS</b>
FX	ZF2.8	13 - 14	<b>HS</b>
FX	ZF5.7	13 - 14	<b>HS</b>
MX	ZF2.8	13 - 13	<b>RSI</b>
MX	ZF5.7	13 - 13	<b>RSI</b>
S	ZF11.4	13 - 14	<b>HS</b>
S	ZF8.5	13 - 14	<b>HS</b>
SR	ZF11.4	14 - 14	<b>HS</b>
XU	ZF2.8	13 - 13	<b>HS</b>
XU	ZF5.7	13 - 13	<b>HS</b>

STREET  
AMERICAN  
SCOOTER

HF • HS • LS  
H.HF • H.CT • H.HS • H.LS  
HF • CT • MS

RACING  
OFF ROAD  
ATV

RST • DC • DCC • DS-1 • DS-2 • RQ  
SI • RSI • CS  
ATS • SI • RSI • PSI

Available compounds

HF • HS • CS • SI • RSI

SBS 694

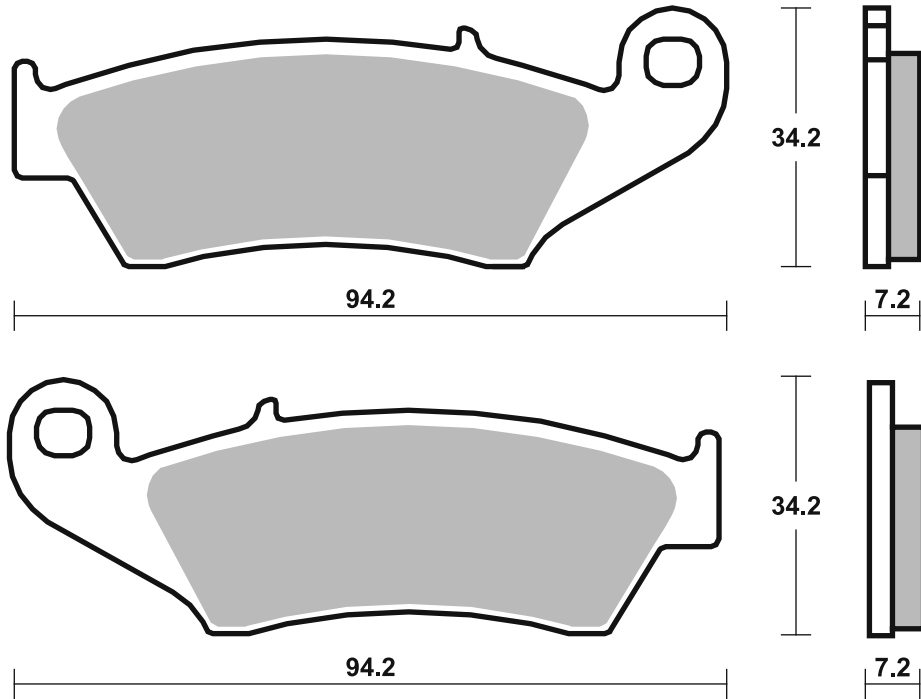

## Applications

### SBS 695

### Recommended compound



<b>APRILIA</b>			
SXV	450 Van den Bosch		
	Rep.	08 - 10	<b>RST</b>
SXV	550 Van den Bosch		
	Rep.	08 - 10	<b>RST</b>
<b>BREMBO RACING CALIPERS</b>			
GP X10.48.13/14, racing			
<b>GALESPEED</b>			
4 Piston Axial Front Caliper, GSFCAR3430AF(Right)/ GSFCAL3430AF(Left)			
4 Piston Axial Front Caliper, GSFCAR3430AT(Right)/ GSFCAL3430AT(Left)			
4 Piston Radial Front Caliper, GSFCAR3430F(Right)/ GSFCAL3430F(Left)			



<b>GALESPEED</b>			
4 Piston Radial Front Caliper, GSFCAR3430T (Right)/GSFCAL3430T(Left)			

### SBS 697

### Recommended compound



<b>BENELLI</b>			
666	125 Born in Hell	98 - 98	<b>HF</b>

### SBS 699

### Recommended compound



<b>JAWA</b>			
	350	93 - 95	<b>HF</b>

Brake Pad 1:1 Drawings,  
Compounds, Fitments

STREET  
AMERICAN  
SCOOTER

HF • HS • LS  
H.HF • H.CT • H.HS • H.LS  
HF • CT • MS

RACING  
OFF ROAD  
ATV

RST • DC • DCC • DS-1 • DS-2 • RQ  
SI • RSI • CS  
ATS • SI • RSI • PSI

Drawings 1:1

Available compounds

DC • RST • DS-1 • DS-2

SBS 695

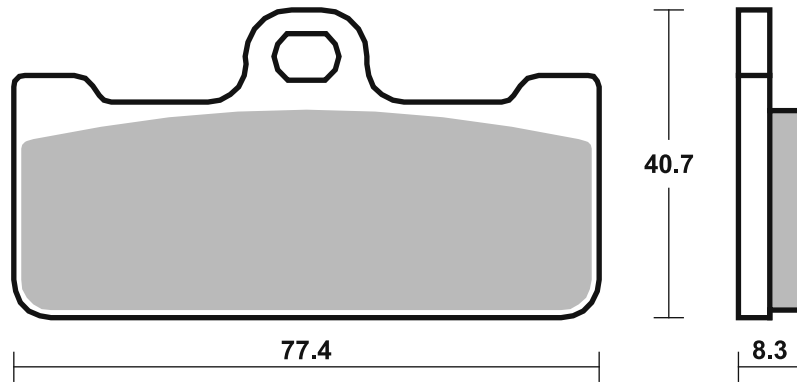

Available compounds

HF

SBS 697

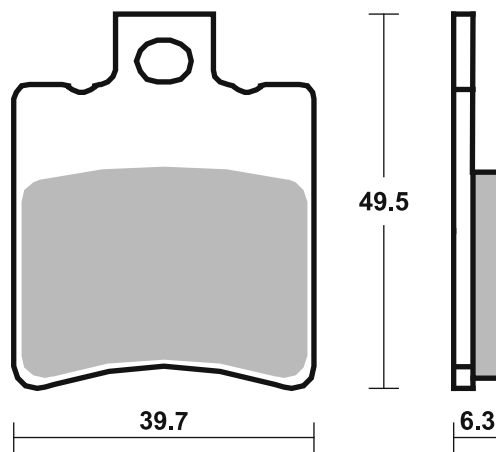

Available compounds

HF

SBS 699

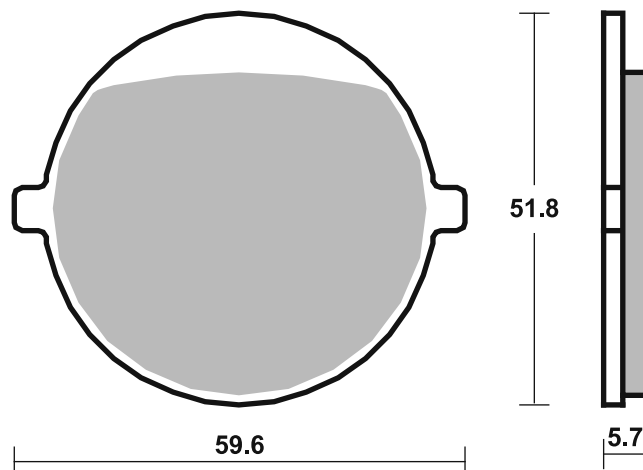

**Applications**

**SBS 700 Recommended compound**



<b>BRIXTON</b>			
1200 Cromwell	15 - 23	<b>HS</b>	
<b>DAELIM</b>			
125 Roadwin	04 - 12	<b>HF</b>	
125 Rocket	99 - 01	<b>HF</b>	
VL 125 Daystar	00 - 12	<b>HF</b>	
VT 125 Evolution	00 - 03	<b>HF</b>	
VT 125 Magna	97 - 99	<b>HF</b>	
250 Roadwin	08 - 12	<b>HF</b>	

<b>HONDA</b>			
CBR 250 RR	17 - 21	<b>HS</b>	
CBR 300 F	14 - 16	<b>HS</b>	
CBR 300 F ABS	14 - 17	<b>HS</b>	
CBR 300 R	14 - 23	<b>HS</b>	
CMX 300 Rebel	17 - 18	<b>HS</b>	
VRX 400 T Roadstar	95 - 99	<b>HS</b>	
CB 500 F	13 - 21	<b>HS</b>	
CB 500 X	13 - 21	<b>HS</b>	
CBF 500	04 - 08	<b>HS</b>	
CBR 500 R	13 - 21	<b>HS</b>	
CL 500	23 - 24	<b>HS</b>	
CMX 500 Rebel	17 - 23	<b>HS</b>	
CMX 500 Rebel S	20 - 20	<b>HS</b>	
SCL 500	23 - 24	<b>HS</b>	
XL 600 V, Transalpino	94 - 96	<b>HS</b>	
CBR 650 F ABS	14 - 20	<b>HS</b>	
DN-01 680	08 - 11		<b>LS</b>
CTX 700 D ABS w/DCT	13 - 15	<b>HS</b>	
CTX 700 N	14 - 18	<b>HS</b>	
CTX 700 ND ABS w/DCT	14 - 15	<b>HS</b>	
CTX 700	14 - 18	<b>HS</b>	
NC 750 S w/DCT	14 - 21	<b>HS</b>	
NC 750 X w/DCT	14 - 19	<b>HS</b>	
NC 750 XAE	14 - 19	<b>HS</b>	
NM4 750 Vultus ABS w/DCT	15 - 18	<b>HS</b>	
VF 750 C, CD Magna	94 - 98	<b>HS</b>	
VFR 750 F	88 - 98		<b>LS</b>
VT 750 Black Widow	01 - 03	<b>HS</b>	
VT 750 C2 Shadow A.C.E.	97 - 03	<b>HS</b>	
VT 750 C2 Shadow Spirit	07 - 11	<b>HS</b>	
VT 750 C2B	11 - 18	<b>HS</b>	
VT 750 C4 Shadow	04 - 05	<b>HS</b>	
VT 750 RS	11 - 13	<b>HS</b>	
VT 750 S	11 - 12	<b>HS</b>	
750 Shadow Aero	24 - 24	<b>HS</b>	



<b>HONDA</b>			
750 Shadow Phantom	24 - 24	<b>HS</b>	
VFR 950 F, Carat	92 - 92		<b>LS</b>
CBF 1000 Limited Edition	09 - 14	<b>HS</b>	
CBF 1000	06 - 11	<b>HS</b>	
CBR 1000 F	89 - 92		<b>LS</b>
VFR 1000	89 - 89		<b>LS</b>
CTX 1300	14 - 18	<b>LS</b>	
GL 1500 F6 C Valkyrie	96 - 02	<b>LS</b>	

<b>INDIAN</b>			
1768 Pursuit			
Dark Horse	22 - 23		<b>H.LS</b>
1768 Pursuit Limited	22 - 23		<b>H.LS</b>
1800 Challenger	20 - 23		<b>H.LS</b>
1800 Challenger Dark Horse	20 - 23		<b>H.LS</b>
1800 Challenger Elite	22 - 23		<b>H.LS</b>
1800 Challenger Limited	20 - 23		<b>H.LS</b>
1800 Chief	15 - 23		<b>H.LS</b>
1800 Chief Bobber	22 - 23		<b>H.LS</b>
1800 Chief Bobber Dark Horse	22 - 23		<b>H.LS</b>
1800 Chief Classic	14 - 18		<b>H.LS</b>
1800 Chief Dark Horse	15 - 23		<b>H.LS</b>
1800 Chief Vintage	14 - 19		<b>H.LS</b>
1800 Chieftain	14 - 23		<b>H.LS</b>
1800 Chieftain Classic	15 - 18		<b>H.LS</b>
1800 Chieftain Dark Horse	15 - 23		<b>H.LS</b>
1800 Chieftain Limited	15 - 23		<b>H.LS</b>
1800 Roadmaster	15 - 23		<b>H.LS</b>
1800 Roadmaster Classic	15 - 18		<b>H.LS</b>
1800 Roadmaster Dark Horse	20 - 23		<b>H.LS</b>
1800 Roadmaster Elite	15 - 21		<b>H.LS</b>
1800 Roadmaster Limited	21 - 23		<b>H.LS</b>
1800 Springfield	16 - 23		<b>H.LS</b>
1800 Springfield Dark Horse	15 - 23		<b>H.LS</b>
1800 Super Chief	22 - 23		<b>H.LS</b>
1800 Super Chief Limited	22 - 23		<b>H.LS</b>



<b>TRIUMPH</b>			
900 Adventurer	96 - 02		<b>LS</b>
900 Legend TT	99 - 01		<b>LS</b>
900 Thunderbird	96 - 05		<b>LS</b>
900 Thunderbird Sport	03 - 04		<b>LS</b>
900 Tiger	99 - 00		<b>LS</b>

<b>VICTORY</b>			
1634 Hammer	08 - 08		<b>H.LS</b>
1634 Kingpin all models	08 - 12		<b>H.LS</b>
1634 Vegas	08 - 17		<b>H.LS</b>
1634 Vegas 8-Ball	08 - 17		<b>H.LS</b>
1634 Vegas Jackpot	08 - 08		<b>H.LS</b>
1731 Boardwalk	13 - 15		<b>H.LS</b>
1731 Cross Country	10 - 17		<b>H.LS</b>
1731 Cross Country 8-Ball	14 - 16		<b>H.LS</b>
1731 Cross Country Tour	12 - 17		<b>H.LS</b>
1731 Cross Roads	10 - 12		<b>H.LS</b>
1731 Cross Roads 8-Ball	14 - 14		<b>H.LS</b>
1731 Cross Roads Classic	14 - 14		<b>H.LS</b>
1731 Gunner	15 - 17		<b>H.LS</b>
1731 Hammer	09 - 11		<b>H.LS</b>
1731 Hammer 8-Ball	10 - 16		<b>H.LS</b>
1731 Hammer S	09 - 17		<b>H.LS</b>
1731 Hard-Ball	12 - 13		<b>H.LS</b>
1731 High-Ball	12 - 17		<b>H.LS</b>
1731 Jackpot	10 - 16		<b>H.LS</b>
1731 Judge	13 - 17		<b>H.LS</b>
1731 Kingpin	10 - 12		<b>H.LS</b>
1731 Kingpin 8-Ball	10 - 11		<b>H.LS</b>
1731 Magnum	15 - 17		<b>H.LS</b>
1731 Magnum X-1	15 - 17		<b>H.LS</b>
1731 Vegas	10 - 17		<b>H.LS</b>
1731 Vegas 8-Ball	10 - 17		<b>H.LS</b>
1731 Vegas Jackpot	09 - 09		<b>H.LS</b>
1731 Vision all models	08 - 17		<b>H.LS</b>

<b>VOGE</b>			
ACX 500	23 - 23	<b>HS</b>	

**SBS 701 Recommended compound**



<b>SUZUKI</b>			
RF 900 RR,RS,RS2,T,V	94 - 97		<b>LS</b>

Brake Pad 1:1 Drawings, Compounds, Fitments



STREET  
AMERICAN  
SCOOTER

HF • HS • LS  
H.HF • H.CT • H.HS • H.LS  
HF • CT • MS

RACING  
OFF ROAD  
ATV

RST • DC • DCC • DS-1 • DS-2 • RQ  
SI • RSI • CS  
ATS • SI • RSI • PSI

Drawings 1:1

Available compounds

HF • HS • LS • DC • RST • DS-1 • DS-2 • H.HF • H.CT • H.LS

SBS 700

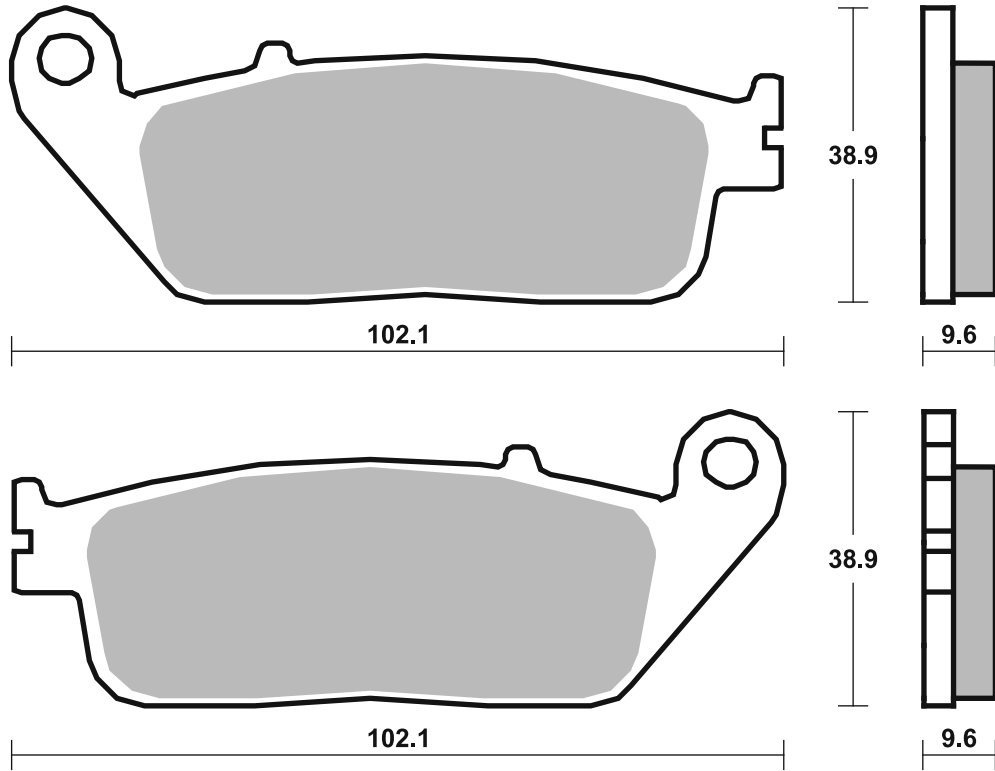

Available compounds

HF • LS

SBS 701

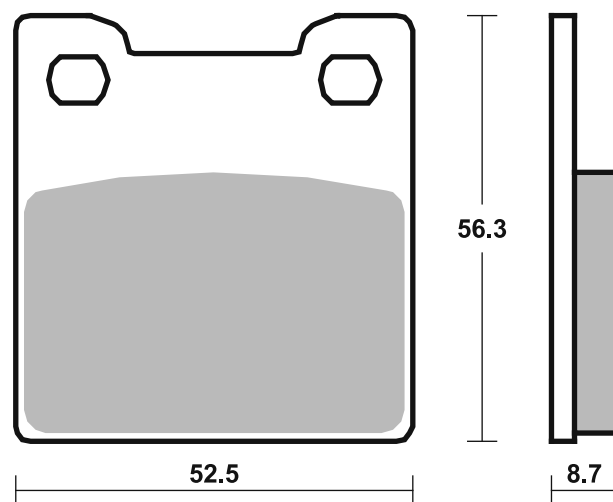

Dimensions in mm / Dimensions en mm  
1" = 25.4 mm , 1 mm = 0.04"

Brake Pad 1:1 Drawings,  
Compounds, Fitments

Applications

**SBS 702**

**Recommended compound**



**KAWASAKI**

KLX	125 L	03 -06	<b>SI</b>
-----	-------	--------	-----------

**SUZUKI**

RM	80	96 -01	<b>RSI</b>
----	----	--------	------------

RM	85	02 -04	<b>RSI</b>
----	----	--------	------------

DR-Z	125 L	03 -24	<b>SI</b>
------	-------	--------	-----------

**SBS 703**

**Recommended compound**



**BMW**

R	850 C	99 -01	<b>HS</b>
---	-------	--------	-----------

R	850 GS	99 -07	<b>HS</b>
---	--------	--------	-----------

R	850 R	96 -02	<b>HS</b>
---	-------	--------	-----------

R	850 RT	96 -01	<b>HS</b>
---	--------	--------	-----------

R	1100 GS	94 -01	<b>HS</b>
---	---------	--------	-----------

R	1100 R Cast wheels	99 -01	<b>HS</b>
---	--------------------	--------	-----------

R	1100 R Spoke wheels	99 -06	<b>HS</b>
---	---------------------	--------	-----------

R	1100 RT Cast wheels	95 -01	<b>HS</b>
---	---------------------	--------	-----------

R	1100 RT Spoke wheels	95 -01	<b>HS</b>
---	----------------------	--------	-----------

R	1100 S	99 -00	<b>HS</b>
---	--------	--------	-----------

R1100	1100 RS	94 -01	<b>HS</b>
-------	---------	--------	-----------

R	1150 GS	00 -01	<b>HS</b>
---	---------	--------	-----------

K	1200 LT	99 -00	<b>HS</b>
---	---------	--------	-----------

K	1200 RS	97 -00	<b>HS</b>
---	---------	--------	-----------

R	1200 C	98 -02	<b>HS</b>
---	--------	--------	-----------

Brake Pad 1:1 Drawings, Compounds, Fitments

STREET  
AMERICAN  
SCOOTER

HF • HS • LS  
H.HF • H.CT • H.HS • H.LS  
HF • CT • MS

RACING  
OFF ROAD  
ATV

RST • DC • DCC • DS-1 • DS-2 • RQ  
SI • RSI • CS  
ATS • SI • RSI • PSI

Drawings 1:1

Available compounds

HF • CS • SI • RSI

SBS 702

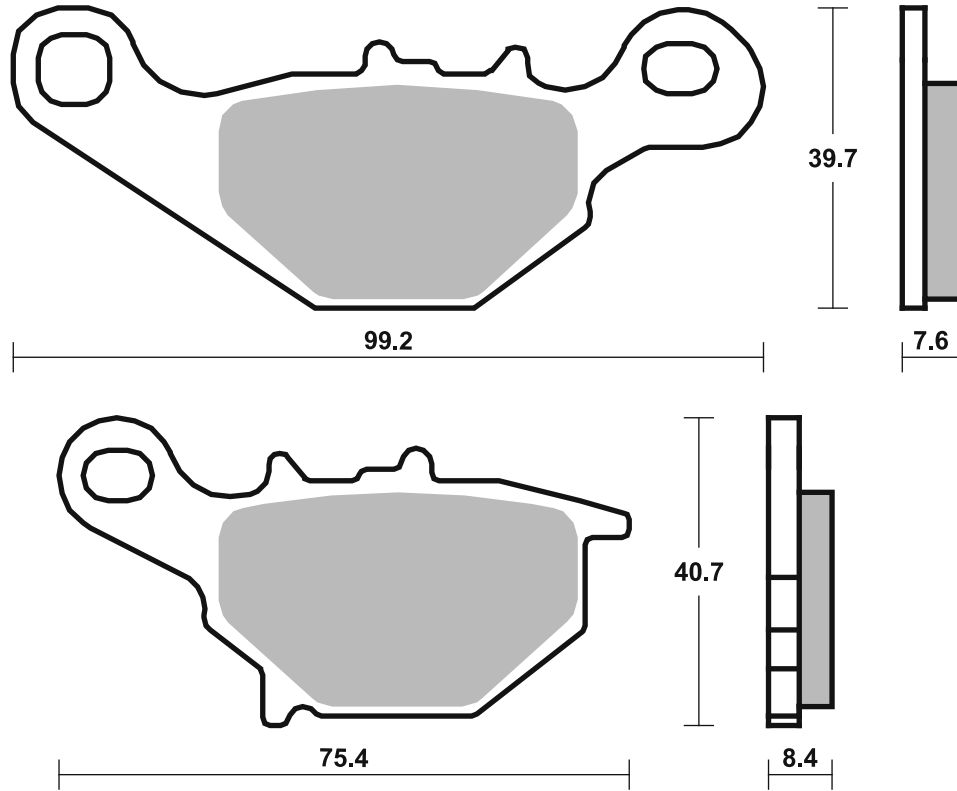

Available compounds

HF • HS

SBS 703

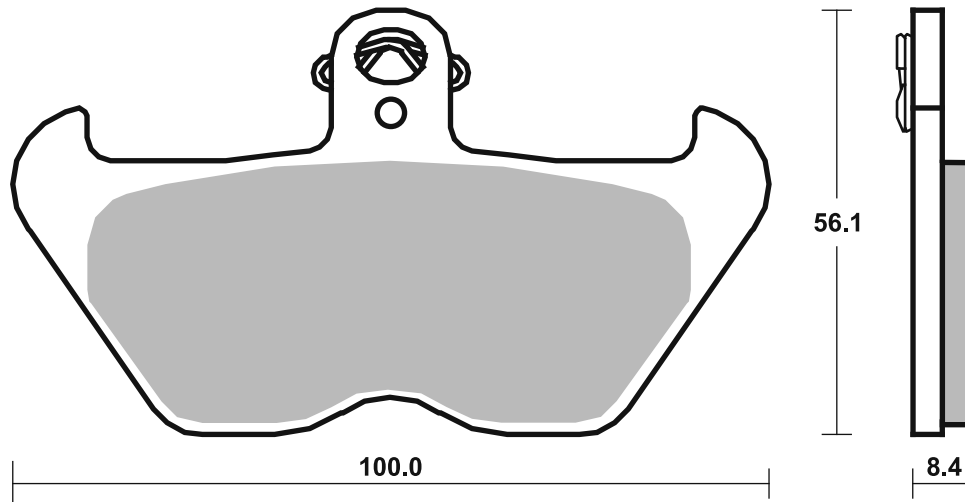

## Applications

### SBS 704

### Recommended compound



KAWASAKI			
	400 Ninja R	11 - 11	HS
ER-6f	650	06 - 16	HS
ER-6n	650	06 - 16	HS
KLE	650 Versys	07 - 14	HS
KLE	650 Versys ABS	07 - 14	HS
W	650	99 - 05	HF
Z	750	04 - 06	HS
Z	750 S	05 - 06	HS
ZR	750 Zephyr	96 - 97	HS
ZR-7	750	99 - 04	HS LS
ZR-7	750	99 - 04	HS LS
ZR-7S	750	01 - 04	HS LS
ZR-7S	750	01 - 04	HS LS
VN	800 Drifter	99 - 02	HS LS
W	800	11 - 16	HS
W	800	20 - 24	HS
W	800 Cafe	19 - 22	HS
W	800 Street	19 - 22	HS
KLV	1000	04 - 07	HS
	1100 Zephyr	97 - 02	HS
GPZ	1100 (ZX 1100)	95 - 99	HS
GPZ	1100 ABS, Horizont	97 - 99	HS
VN	1500 Classic Tourer	98 - 01	HS
VN	1500 Classic Tourer Fi	00 - 04	HS
VN	1500 Drifter	99 - 02	HS LS
VN	1600 Classic	03 - 08	HS
VN	1700 Classic	09 - 14	HS
VN	1700 Classic Tourer	09 - 14	HS
SUZUKI			
RV	125 VanVan	03 - 18	HF



SUZUKI			
RV	200 VanVan	16 - 19	HF
GS	500	96 - 08	HS
GS	500 F	04 - 08	HS
GSF	600 Bandit / S Bandit	00 - 04	HS
GSX	600 FW	98 - 04	HS
DL	650 V-Strom	04 - 24	HS
DL	650 V-Strom XT	15 - 24	HS
GSF	650 Bandit / S Bandit	05 - 05	HS
GSF	650 Bandit / S Bandit		
	ABS	06 - 06	HS
SFV	650 Gladius	09 - 16	HS
SV	650	16 - 18	HS
SV	650 S	99 - 12	HS
SV	650 S	03 - 12	HS
SV	650 X	18 - 18	HS
XF	650 Freewind	97 - 02	HS
GSR	750	11 - 16	HS
GSX	750	98 - 08	HS
GSX	750 F	03 - 06	HS
GSX	750 FW	98 - 02	HS
GSX-S	750	15 - 16	HS
GSX-S	750 Z	15 - 16	HS
C	800 Intruder	05 - 18	HS
M	800 Intruder	05 - 18	HS
VL	800 Intruder LC		
	Volusia	01 - 04	HS
VZ	800 Marauder	97 - 04	HS
DL	1000 V-Strom	02 - 13	HS
GSX	1100 G	96 - 98	HS
C	1500 Intruder	05 - 10	HS
M	1500 Intruder	09 - 18	HS



SUZUKI			
VL	1500 Intruder LC	02 - 02	HS

### SBS 705

### Recommended compound



KAWASAKI			
	400 Ninja R	11 - 11	HS
ER-5	500	01 - 07	HS
ER-6f	650	06 - 16	HS
ER-6n	650	06 - 16	HS
KLE	650 Versys	07 - 14	HS
KLE	650 Versys ABS	07 - 14	HS
KLR	650	95 - 04	HS
Z	750	04 - 06	HS
Z	750 S	05 - 06	HS
ZR	750 Zephyr	96 - 97	HS
ZR-7	750	99 - 04	HS
ZR-7S	750	01 - 04	HS
VN	800 Classic	98 - 99	HS
VN	800 Drifter	99 - 02	HS
VN	900 Classic	06 - 16	HS
VN	900 Classic SE	11 - 16	HS
VN	900 Custom	07 - 16	HS
KLV	1000	04 - 07	HS
	1100 Zephyr	97 - 02	HS
GPZ	1100 (ZX 1100)	95 - 99	HS
GPZ	1100 ABS, Horizont	97 - 99	HS
VN	1500 Classic	97 - 04	HS
VN	1500 Classic Fi	00 - 04	HS
VN	1500 Classic Tourer	98 - 01	HS
VN	1500 Classic Tourer		
	Fi	00 - 04	HS
VN	1500 Drifter	99 - 02	HS
VN	1600 Classic	03 - 08	HS
VN	1700 Classic	09 - 14	HS
VN	1700 Classic Tourer	09 - 14	HS



SUZUKI			
GSF	250 VS, S Bandit	95 - 00	HS
TU	250 X	09 - 19	HF
GSF	600 Bandit / S Bandit	00 - 04	HS
GSX	600 FW	98 - 04	HS
DL	650 V-Strom	04 - 24	HS
DL	650 V-Strom XT	15 - 24	HS
GSF	650 Bandit / S Bandit	05 - 05	HS
GSF	650 Bandit / S Bandit		
	ABS	06 - 06	HS
SFV	650 Gladius	09 - 16	HS
SV	650	16 - 18	HS
SV	650 S	99 - 12	HS
SV	650 S	03 - 12	HS
SV	650 S ABS	07 - 18	HS
SV	650 X	18 - 18	HS
GSR	750	11 - 16	HS
GSX	750	98 - 08	HS
GSX	750 F	03 - 06	HS
GSX	750 FW	98 - 02	HS
GSX-S	750	15 - 16	HS
GSX-S	750 Z	15 - 16	HS
DR	800 ST Big	96 - 98	HS
DL	1000 V-Strom	02 - 13	HS
GSX	1100 G	96 - 98	HS
C	1500 Intruder	05 - 10	HS
M	1500 Intruder	09 - 18	HS
VL	1500 Intruder LC	02 - 02	HS

STREET HF • HS • LS  
 AMERICAN H.HF • H.CT • H.HS • H.LS  
 SCOOTER HF • CT • MS

RACING  
 OFF ROAD  
 ATV

RST • DC • DCC • DS-1 • DS-2 • RQ  
 SI • RSI • CS  
 ATS • SI • RSI • PSI

Drawings 1:1

Available compounds

HF • HS • LS • RST

SBS 704

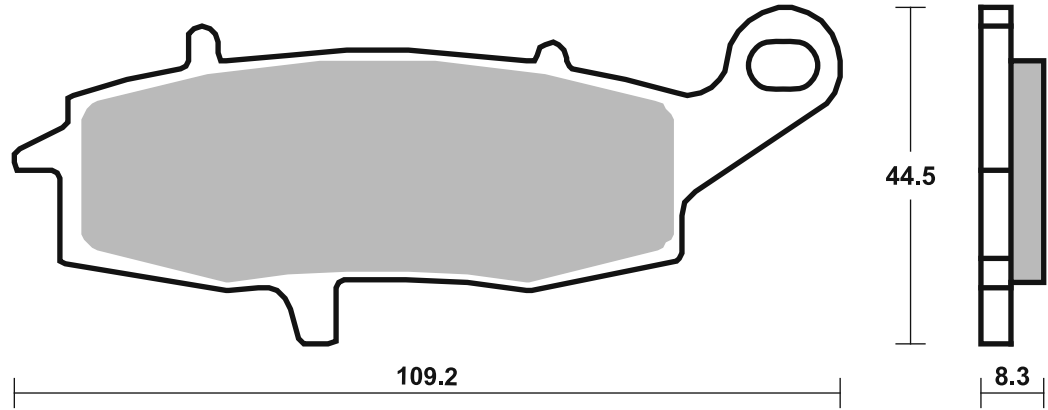
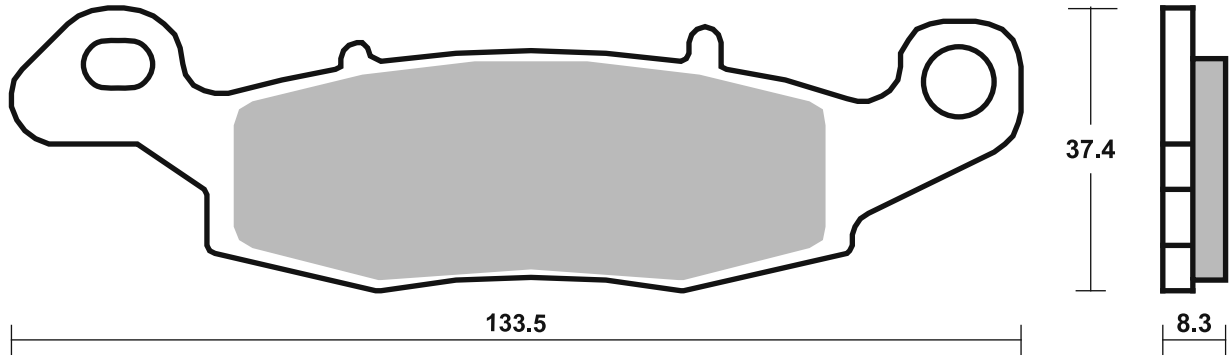

Available compounds

HF • HS • RST

SBS 705

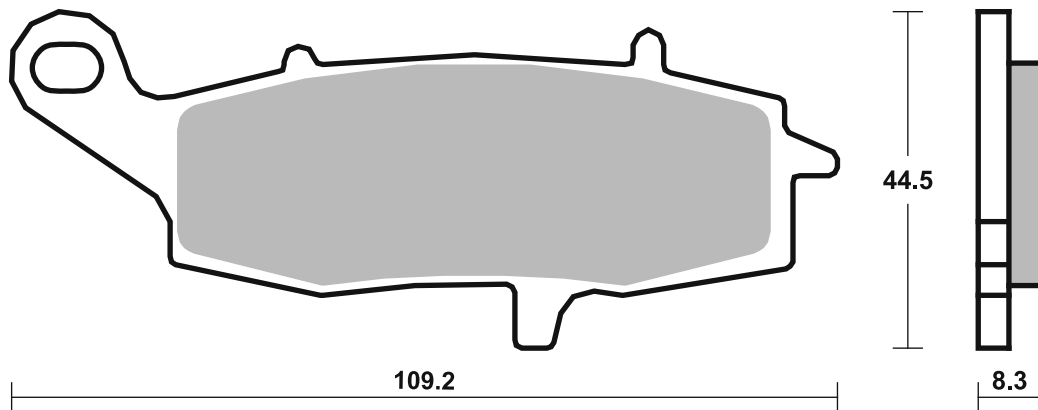
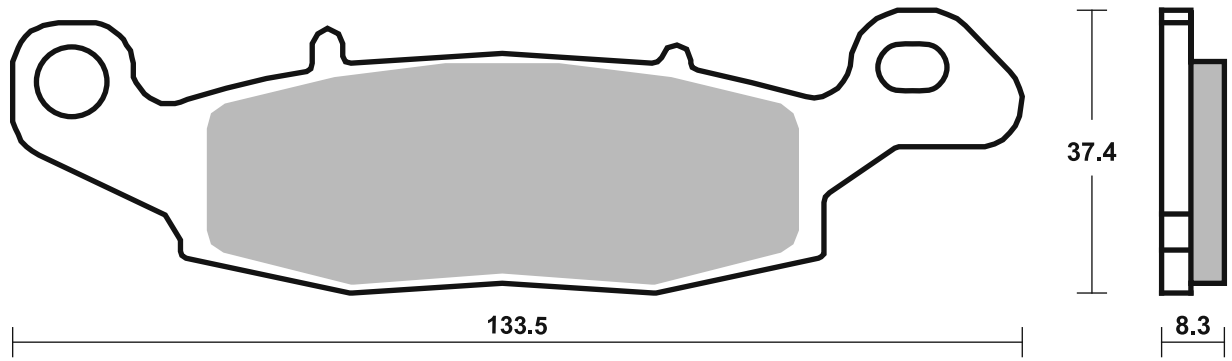



<b>APRILIA</b>			
RS	250	97 -02	<b>HF</b>
RS	250 Pista	04 -04	<b>HF</b>
	650 Pegaso Strada	05 -09	<b>HS</b>
	750 Dorsoduro		
	Factory	12 -13	<b>HS</b>
SMV	750 Dorsoduro	08 -08	<b>HS</b>
	1000 Blue Marlin	02 -02	<b>HS</b>
RST	1000 Futura	01 -03	<b>HS</b>
RSV	1000	97 -01	<b>HS</b>
RSV	1000 Falco SL, R	00 -04	<b>HS</b>
RSV	1000 R	00 -00	<b>HS</b>
RSV	1000 SP	00 -00	<b>HS</b>
RSV	1000 Tuono Fighter	03 -05	<b>HS</b>
RSV	1000 Tuono R, ABS	04 -12	<b>HS</b>
RSV	1000 Tuono V4 R	11 -13	<b>HS</b>
	1200 Dorsoduro, ABS	11 -14	<b>HS</b>

<b>BENELLI</b>			
666	125 Born in Hell	98 -98	<b>HF</b>
BKX	125	23 -23	<b>HF</b>
BKX	125 S	23 -23	<b>HF</b>
BKX	250	23 -23	<b>HF</b>
BKX	250 S	23 -23	<b>HF</b>
BN	302	14 -14	<b>HS</b>
	402 S	18 -19	<b>HS</b>
	500 Leoncino	16 -17	<b>HS</b>
TRK	502	16 -17	<b>HS</b>
BN	600	12 -13	<b>HS</b>
	756 Cue	10 -12	<b>HS</b>
	899 Trek	07 -12	<b>HS</b>
TNT	899	07 -15	<b>HS</b>
	900 Tornado 3	00 -06	<b>HS</b>
TNT	1100	04 -04	<b>HS</b>
TNT	1130	05 -14	<b>HS</b>
TNT	1130 Trek	06 -12	<b>HS</b>
TNT	1130 Trek Amazonas	07 -15	<b>HS</b>

<b>BIMOTA</b>			
DB4	900	99 -00	<b>HS</b>
SB8	1000 R	98 -00	<b>HS</b>
SB8K	1000	06 -06	<b>HS</b>

<b>BMW</b>			
G	650 Xmoto	06 -07	<b>HS</b>
F	800 GT	13 -20	<b>HS</b>
F	800 R	09 -14	<b>HS</b>
F	800 S	06 -10	<b>HS</b>
F	800 ST	06 -12	<b>HS</b>
F	800 ST Touring	11 -12	<b>HS</b>
R	1200 NineT Pure	17 -23	<b>HS</b>
R	1200 NineT Racer	17 -20	<b>HS</b>
R	1200 NineT		
	Scrambler	16 -23	<b>HS</b>
R	1200 NineT Urban GS	17 -23	<b>HS</b>

<b>BRACING</b>			
Street, Supermotard			

<b>BRAMMO</b>			
	Empulse	14 -16	<b>H.HS</b>

<b>BREMO RACING CALIPERS</b>			
100 mm Motard Radial XA78910, P4 30/34			
100 mm Radial 220A16810, P4 30/34			
100 mm Radial 220A80310, P4 30/34			
108 mm Motard Radial XA69510, P4 30/34			



<b>BREMO RACING CALIPERS</b>			
108 mm Radial 220A01610, P4 30/34			
108 mm Radial 220A80210, P4 30/34			
Goldline two pin 20.6800, road Radial 220A16820, P4 30/34			

<b>BRIXTON</b>			
BX	500 XC Crossfire	15 -23	<b>HS</b>

<b>CAGIVA</b>			
	650 Raptor	01 -08	<b>HS</b>
	650 V-Raptor	01 -08	<b>HS</b>
	1000 Raptor	00 -08	<b>HS</b>
	1000 V-Raptor	00 -08	<b>HS</b>
	1000 Xtra Raptor	02 -06	<b>HS</b>

<b>CF MOTO</b>			
	125 NK	24 -24	<b>HS</b>
	450 CL-C	24 -24	<b>HS</b>
	450 MT	24 -24	<b>HS</b>
	450 NK	24 -24	<b>HS</b>
	700 CL-X Adventure	24 -24	<b>HS</b>
	700 CL-X Heritage	22 -22	<b>HS</b>
	800 MT Explore	24 -24	<b>HS</b>
	800 MT Sport	22 -22	<b>HS</b>
	800 MT Touring	22 -22	<b>HS</b>
	800 NK	24 -24	<b>HS</b>

<b>DUCATI</b>			
	400 Monster (Japan)	01 -06	<b>HS</b>
	600 Monster	00 -01	<b>HS</b>
	620 Monster Dark i.e.	02 -06	<b>HS</b>
	620 Monster i.e., s i.e.	02 -06	<b>HS</b>
	620 Multistrada Dark	05 -06	<b>HS</b>
	620 Sport	03 -06	<b>HS</b>
	696 Monster	08 -12	<b>HS</b>
	748 , S	99 -02	<b>HS</b>
	748 R	00 -00	<b>HS</b>
	748 SPS	98 -99	<b>HS</b>
	750 Monster	00 -01	<b>HS</b>
	750 Monster i.e.	02 -02	<b>HS</b>
	750 Sport	00 -02	<b>HS</b>
	750 Super Sport	00 -02	<b>HS</b>
	795 Monster	12 -12	<b>HS</b>
	796 Hypermotard	10 -12	<b>HS</b>
	796 Monster	11 -14	<b>HS</b>
	796 Monster ABS	11 -14	<b>HS</b>
	800 Monster Dark i.e., s i.e.	03 -07	<b>HS</b>
	800 Monster i.e., s i.e.	03 -07	<b>HS</b>
	800 Sport	03 -06	<b>HS</b>
	800 Supersport	03 -06	<b>HS</b>
	848	08 -10	<b>HS</b>
	848 Streetfighter	12 -15	<b>HS</b>
	900 Monster	00 -01	<b>HS</b>
	900 Monster i.e.	02 -02	<b>HS</b>
	900 Super Sport	98 -02	<b>HS</b>
MH	900	00 -01	<b>HS</b>
	916 Monster S4	01 -03	<b>HS</b>
	916 Sport Touring 4	99 -01	<b>HS</b>
	916 SPS	97 -98	<b>HS</b>
	944 Sport Touring	98 -03	<b>HS</b>
	944 ST2	97 -03	<b>HS</b>
	992 ST3	04 -07	<b>HS</b>
	992 ST3s ABS	06 -07	<b>HS</b>
	996	99 -01	<b>HS</b>
	996 Monster S4R	04 -06	<b>HS</b>



<b>DUCATI</b>			
	996 S	01 -01	<b>HS</b>
	996 ST4s	02 -06	<b>HS</b>
	996 ST4s ABS	03 -06	<b>HS</b>
	998	02 -04	<b>HS</b>
	998 S	02 -04	<b>HS</b>
	1000 Monster Dark i.e., s i.e.	03 -06	<b>HS</b>
	1000 Monster i.e., s i.e.	03 -06	<b>HS</b>
	1000 Monster S2R	06 -07	<b>HS</b>
	1000 Multistrada	07 -07	<b>HS</b>
	1000 Multistrada DS	03 -06	<b>HS</b>
	1000 Multistrada S DS	05 -06	<b>HS</b>
	1000 Supersport DS	03 -06	<b>HS</b>
	1100 Hypermotard	07 -09	<b>HS</b>
	1100 Hypermotard EVO	10 -12	<b>HS</b>
	1100 Monster	09 -13	<b>HS</b>
	1100 Monster ABS	09 -10	<b>HS</b>
	1100 Monster EVO	11 -13	<b>HS</b>
	1100 Monster EVO ABS	11 -13	<b>HS</b>
	1100 Monster S	09 -13	<b>HS</b>
	1100 Monster S ABS	09 -10	<b>HS</b>
	1100 Multistrada	07 -09	<b>HS</b>
	1100 Multistrada S	07 -09	<b>HS</b>
	1200 Multistrada	10 -14	<b>HS</b>
	1200 Multistrada S GT	12 -14	<b>HS</b>
	1200 Multistrada S Pikes Peak	11 -14	<b>HS</b>
	1200 Multistrada S Sport	10 -14	<b>HS</b>
	1200 Multistrada S Touring	10 -14	<b>HS</b>
	1200 Multistrada Touring ABS	10 -14	<b>HS</b>

<b>FANTIC</b>			
	700 Caballero Scrambler	23 -23	<b>HS</b>

<b>HOREX</b>			
VR6	1200	11 -16	<b>HS</b>

<b>HUSQVARNA</b>			
	570 Nox	01 -03	<b>HF</b>
LT	610	00 -02	<b>HF</b>
SM	610 Super Motard, S	98 -00	<b>HF</b>
SMR	630	04 -08	<b>RST</b>
	701 Svartpilen	18 -19	<b>HS</b>
	701 Vitpilen	18 -20	<b>HS</b>
	900 Nuda	12 -13	<b>HS</b>
	901 Norden	22 -24	<b>HS</b>

<b>KTM</b>			
RC4R	250	20 -20	<b>RST</b>
SMC	625	05 -06	<b>HF</b>
	640 Duke	03 -06	<b>HF</b>
LC4	640 Supermoto	04 -04	<b>HF</b>
SMC	660 Supermoto	04 -07	<b>HF</b>
	690 Duke ABS	12 -19	<b>HS</b>
	690 Supermoto	07 -07	<b>HS</b>
	790 Adventure	19 -24	<b>HS</b>
	790 Adventure R	19 -20	<b>HS</b>
	790 Adventure R Rally	20 -20	<b>HS</b>
	790 Duke	18 -20	<b>HS</b>
	890 Adventure R	21 -24	<b>HS</b>
	890 Adventure R Rally	24 -24	<b>HS</b>

STREET HF • HS • LS  
AMERICAN H.HF • H.CT • H.HS • H.LS  
SCOOTER HF • CT • MS

RACING  
OFF ROAD  
ATV

RST • DC • DCC • DS-1 • DS-2 • RQ  
SI • RSI • CS  
ATS • SI • RSI • PSI

Drawings 1:1

Available compounds

HF • HS • DC • RST • DS-1 • DS-2 • H.HF • H.CT • H.HS

SBS 706

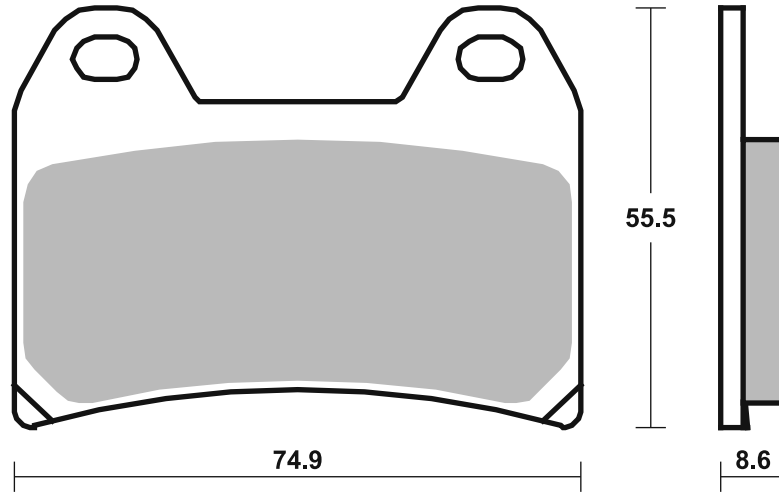

Brake Pad 1:1 Drawings,  
Compounds, Fitsments



KTM			
890 SMT	24 - 24	HS	
1050 Adventure	15 - 16	HS	
1090 Adventure R	17 - 19	HS	
1090 Super Adventure	17 - 19	HS	
1090 Super Adventure R	17 - 20	HS	
1190 Adventure	13 - 16	HS	
1290 Super Adventure	15 - 16	HS	
1290 Super Adventure R	17 - 20	HS	
1290 Super Adventure S	17 - 23	HS	
1290 Super Adventure T	17 - 19	HS	

MBP			
1000 C1002V	23 - 23	HS	
1000 T1002V	23 - 23	HS	

MOTO-GUZZI			
750 Brevia	03 - 09	HS	
750 Nevada Classic			
750 Nevada, Nevada Club	03 - 16	HF	
V7 750 Cafe Classic	10 - 13	HS	
V7 750 Classic	09 - 12	HS	
V7 750 Clubman Racer	10 - 10	HS	
V7 750 Racer	11 - 14	HS	
V7 750 Stone	12 - 14	HS	
V7 II 750 Racer	15 - 16	HS	
V7 II 750 Scrambler	16 - 16	HS	
V7 II 750 Special	15 - 16	HS	
V7 II 750 Stone	15 - 16	HS	
V7 II 750 Stornello	16 - 16	HS	
V7 II 750 Stornello Ltd. Edition	17 - 18	HS	
V7 III 750 Anniversario	17 - 18	HS	
V7 III 750 Carbon	18 - 19	HS	
V7 III 750 Euro 4	17 - 19	HS	
V7 III 750 Limited	19 - 19	HS	
V7 III 750 Milano	18 - 20	HS	
V7 III 750 Racer	17 - 20	HS	
V7 III 750 Rough	18 - 20	HS	
V7 III 750 Special	17 - 19	HS	
V7 III 750 Stone	17 - 20	HS	
V7 850 Brevia	06 - 09	HS	
V7 850 Special	22 - 23	HS	
V7 850 Stone	22 - 23	HS	
V7 850 Stone Fast Endurance	22 - 22	HS	
V7 850 Stone Special Edition	23 - 23	HS	
V85 850 TT	19 - 23	HS	
V85 850 TT Evocative Graphics	23 - 23	HS	
V85 850 TT Guardia d'Onore	22 - 23	HS	
V85 850 TT Travel	20 - 23	HS	
V9 850 Bobber	16 - 17	HS	
V9 850 Bobber Sports	19 - 20	HS	
V9 850 Roamer	16 - 17	HS	
V9 850 X-Track	17 - 17	HS	
940 Custom	07 - 07	HS	
1100 California EV	06 - 06	HS	
1100 California EV Touring	06 - 06	HS	
1100 California Jackal	01 - 06	HS	
1100 California Jackal Basic	01 - 06	HS	



MOTO-GUZZI			
1100 California Special	01 - 01	HS	
1100 California Special Sport Alloy	02 - 06	HS	
1100 California Stone Metal	02 - 03	HS	
1100 California Stone, Stone Touring	02 - 05	HS	
1100 California Titanium	03 - 05	HS	
1100 California Vintage	06 - 13	HS	
1100 Griso	05 - 10	HS	
EV 1100 California, 80, Touring	01 - 01	HS	
V 1100 Brevia	04 - 04	HS	
V 1100 Brevia, ABS	05 - 07	HS	
V11 1100 , Scura, Sport Scura	02 - 05	HS	
V11 1100 Lemans, Lemans Tenni, Lemans Rosso			
V11 1100 Corsa	01 - 06	HS	
V11 1100 Sport Rosso			
V11 1100 Sport Rosso Mandell	01 - 06	HS	
V11 1100 Sport, Sport Naked	01 - 05	HS	
1200 Griso 8V	07 - 13	HS	
1200 Norge	06 - 14	HS	
1200 Norge GT 8V	10 - 13	HS	
1200 Sport	07 - 08	HS	
1200 Sport 4V	09 - 11	HS	
1200 Sport 8V	12 - 13	HS	
1200 Sport 8V SE	12 - 15	HS	
1200 Stelvio	08 - 11	HS	
1200 Stelvio 8V SE	12 - 16	HS	
1200 Stelvio NTX	09 - 11	HS	
V 1200 Brevia	08 - 13	HS	
1400 Audace	15 - 17	HS	
1400 California Custom	13 - 15	HS	
1400 California Touring	13 - 15	HS	
1400 California Touring SE	16 - 17	HS	
1400 Eldorado	15 - 17	HS	
MGX-21 1400 Flying Fortress	15 - 17	HS	

MOTO-MORINI			
1200 11 1/2	18 - 18	HS	
1200 9 1/2	06 - 09	HS	
1200 Corsaro	06 - 13	HS	
1200 Sport	08 - 13	HS	

MV AGUSTA			
675 Brutale	12 - 15	HS	
F3 675	11 - 14	HS	
800 Brutale	13 - 20	HS	
800 Brutale Dragster	15 - 19	HS	
800 Brutale Dragster RC	17 - 20	HS	
800 Brutale Dragster RR	15 - 19	HS	
800 Brutale Dragster RR LH44	18 - 20	HS	
800 Brutale Dragster RR Pirelli	18 - 20	HS	
800 Brutale RC	18 - 20	HS	
800 Brutale Rosso	20 - 21	HS	
800 Brutale RR	16 - 20	HS	
800 Dragster Rosso	20 - 21	HS	
800 RVS#1	18 - 20	HS	
920 Brutale	12 - 14	HS	
989 Brutale R	09 - 09	HS	



MV AGUSTA			
990 Brutale R	10 - 11	HS	
1090 Brutale R	12 - 15	HS	

MZ			
1000 (MUZ) S	01 - 02	HS	

NORTON			
961 Commando SE	10 - 11	HS	
961 Commando SF Sport	11 - 15	HS	

SUZUKI			
GSX 1200	99 - 01	HS	

VICTORY			
Empulse TT	16 - 17	H.HS	
1500 Kingpin	04 - 05	H.HS	
1500 Touring Cruiser	03 - 06	H.HS	
1500 V92C Cruiser	98 - 02	H.HS	
1500 V92C Deluxe	01 - 02	H.HS	
1500 V92SC Sport Cruiser	00 - 02	H.HS	
1500 Vegas	03 - 05	H.HS	
1500 Vegas 8-Ball	05 - 05	H.HS	
1634 Hammer	05 - 07	H.HS	
1634 Hammer S	06 - 08	H.HS	
1634 Kingpin	06 - 07	H.HS	
1634 Kingpin Tour	06 - 07	H.HS	
1634 Vegas	06 - 07	H.HS	
1634 Vegas 8-Ball	06 - 07	H.HS	
1634 Vegas Jackpot	06 - 07	H.HS	

VOGE			
525 CU	24 - 24	HS	

VOXAN			
VB1 1000 EVO	04 - 06	HS	

YAMAHA			
XJR 400 R	95 - 96	HS	
XT 660 X	04 - 13	HS	
TRX 850 (Italy)	95 - 99	HS	
XJR 1200 (Italy)	95 - 98	HS	

ZERO			
DS ZF17.3	24 - 24	HS	
DSR/X ZF17.3	23 - 23	HS	
DSRBF ZF14.4	19 - 21	HS	
S ZF14.4	24 - 24	HS	
SR ZF15.6	24 - 24	HS	
SR ZF17.3	24 - 24	HS	
SR/F ZF14.4	19 - 21	HS	
SR/F ZF17.3	24 - 24	HS	
SR/S ZF14.4	19 - 22	HS	



STREET HF • HS • LS  
AMERICAN H.HF • H.CT • H.HS • H.LS  
SCOOTER HF • CT • MS

RACING  
OFF ROAD  
ATV

RST • DC • DCC • DS-1 • DS-2 • RQ  
SI • RSI • CS  
ATS • SI • RSI • PSI

Drawings 1:1

Available compounds

HF • HS • DC • RST • DS-1 • DS-2 • H.HF • H.CT • H.HS

SBS 706

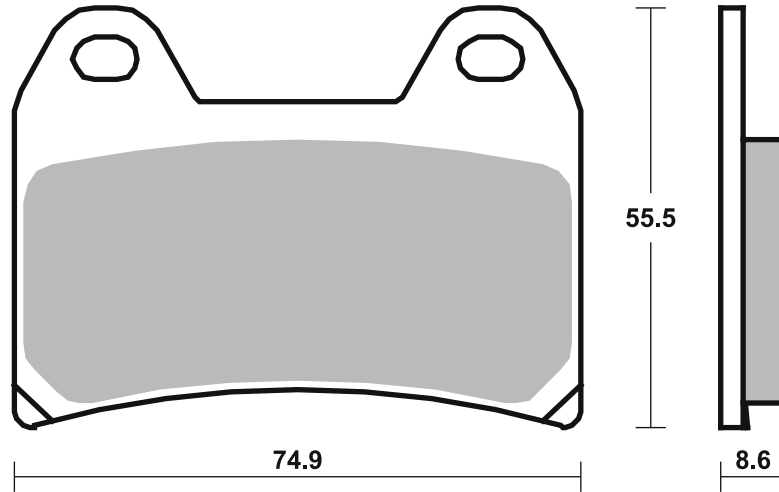

# Applications

## SBS 707

### Recommended compound



#### A.P. RACING CALIPERS

6 Piston 4466/4477 Series

#### PFM

6 Piston Racing Caliper

## SBS 708

### Recommended compound



#### SYM

	125 Attila	95 - 02	HF
H01	150	95 - 00	HF

#### ZERO

DS	ZF6.0	10 - 12	HF
DS	ZF9.0	10 - 12	HF
MX		10 - 12	HF
S	ZF6.0	10 - 12	HF
X		10 - 12	HF
XU		11 - 12	HF

Brake Pad 1:1 Drawings, Compounds, Fitments

STREET  
AMERICAN  
SCOOTER

HF • HS • LS  
H.HF • H.CT • H.HS • H.LS  
HF • CT • MS

RACING  
OFF ROAD  
ATV

RST • DC • DCC • DS-1 • DS-2 • RQ  
SI • RSI • CS  
ATS • SI • RSI • PSI

Drawings 1:1

Available compounds

RST • DS-1 • RQ

SBS 707

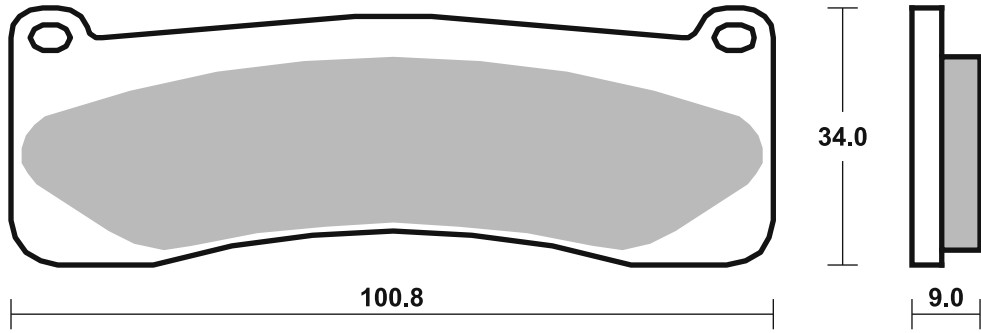

Available compounds

HF

SBS 708

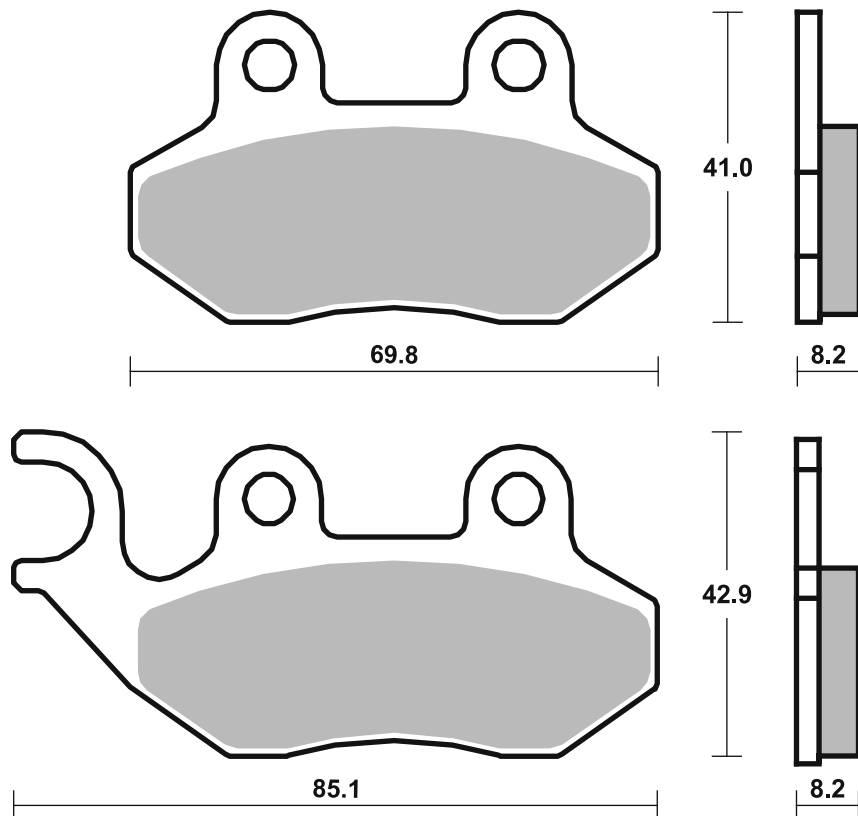

## Applications

### SBS 709 Recommended compound



#### YAMAHA

Model	Year Range	Compound
YFZ 450 S	06 - 09	SI
YFM 700 Raptor	13 - 14	SI

### SBS 711 Recommended compound



#### BREMBO RACING CALIPERS

100 mm Radial Monoblock
XA7G210/11, P4 32/36
100 mm Radial Monoblock
XA7G240/41, P4 32/36
Monoblock X101740/41,
P4 32/36
Radial Monoblock X973760/61,
P4 32/36
Radial Monoblock XA93310/11
Radial XA3B830/31, P4 32/36
Radial XA3B860/61, P4 32/36

#### NISSIN

4 Piston Racing Caliper (1)

STREET HF • HS • LS  
AMERICAN H.HF • H.CT • H.HS • H.LS  
SCOOTER HF • CT • MS

RACING  
OFF ROAD  
ATV

RST • DC • DCC • DS-1 • DS-2 • RQ  
SI • RSI • CS  
ATS • SI • RSI • PSI

Drawings 1:1

Available compounds

HF • LS • SI • RSI

SBS 709

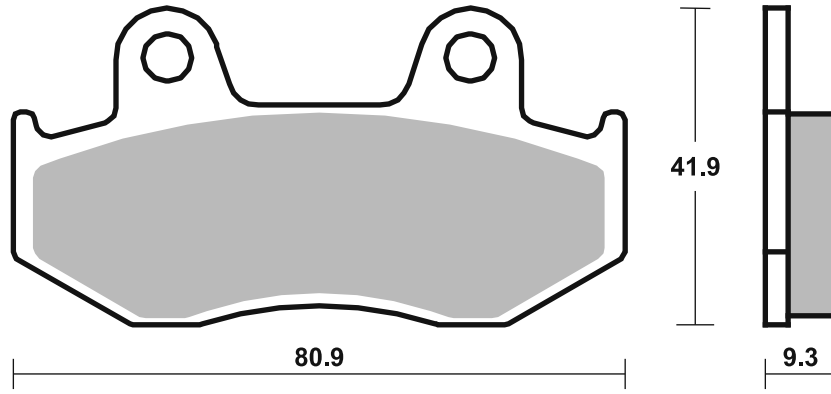

Available compounds

DC • RST • DS-1 • DS-2

SBS 711

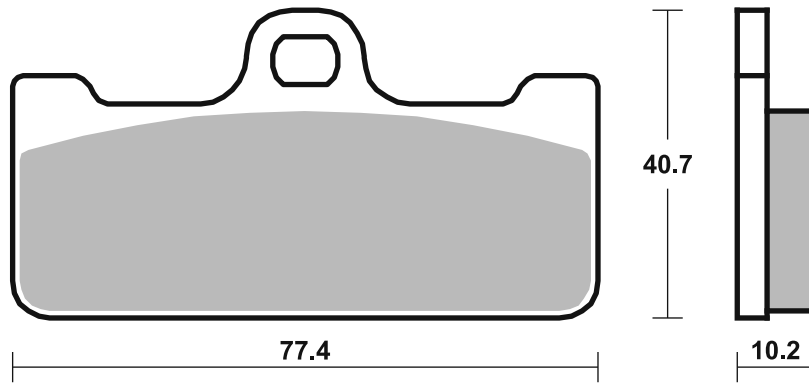

## Applications

### SBS 713

### Recommended compound



<b>HONDA</b>			
CA	125 Rebel	95 - 96	<b>HF</b>
CMX	250 C Rebel	96 - 00	<b>HF</b>
<b>JINCHENG</b>			
JC	250	06 - 09	<b>HF</b>
<b>KEEWAY</b>			
	125 Superlight	06 - 16	<b>HF</b>
	150 Superlight	06 - 16	<b>HF</b>
	250 Land Cruiser	06 - 14	<b>HF</b>
<b>KREIDLER</b>			
	125 Enduro	07 - 08	<b>HF</b>
	125 Supermoto	07 - 08	<b>HF</b>
	200 Enduro	07 - 08	<b>HF</b>
<b>MZ</b>			
	125 SM, SX	02 - 08	<b>HF</b>
<b>QUINGOI</b>			
QM	125 GY	02 - 05	<b>HF</b>

### SBS 714

### Recommended compound



<b>SUZUKI</b>			
RF	900 RR,RS,RS2,T,V	94 - 97	<b>HS</b>
GSF	1200 Bandit	97 - 00	<b>HS</b>

STREET HF • HS • LS  
 AMERICAN H.HF • H.CT • H.HS • H.LS  
 SCOOTER HF • CT • MS

RACING  
 OFF ROAD  
 ATV

RST • DC • DCC • DS-1 • DS-2 • RQ  
 SI • RSI • CS  
 ATS • SI • RSI • PSI

Drawings 1:1

Available compounds

HF

SBS 713

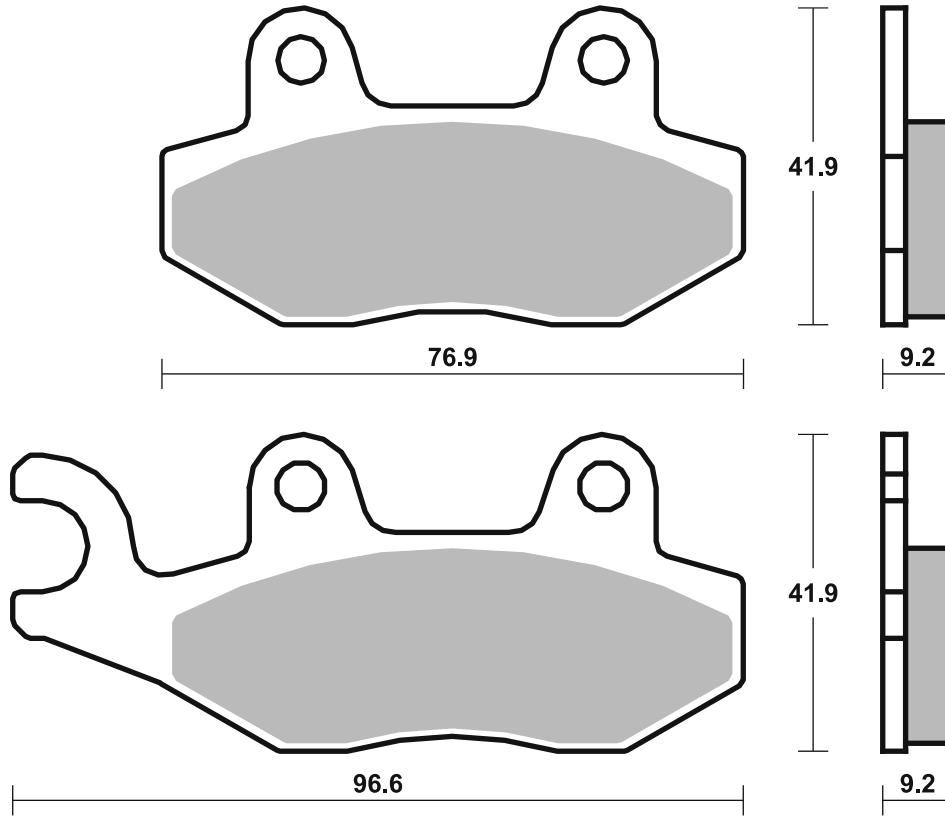

Available compounds

HF • HS

SBS 714

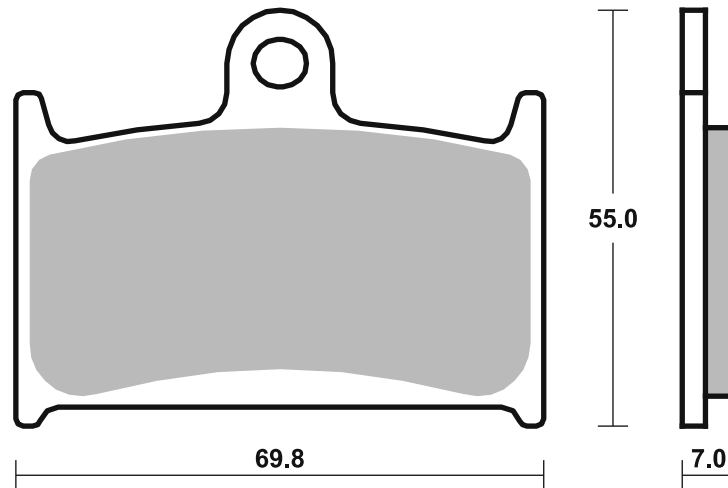

## Applications

### SBS 715

### Recommended compound



HARLEY DAVIDSON			
XL	883 L Super Low	14 - 18	H.LS
XL	883 N Iron	14 - 22	H.LS
XL	883 R Roadster	14 - 15	H.LS
XL	1200 C, CA, CB, CP Custom	14 - 19	H.LS
XL	1200 CX	17 - 17	H.LS
XL	1200 Iron	18 - 22	H.LS
XL	1200 Roadster	18 - 20	H.LS
XL	1200 T Super Low	15 - 17	H.LS
XL	1200 V Seventy-Two	14 - 16	H.LS
XL	1200 X Forty-Eight	14 - 22	H.LS
XL	1200 X Forty-Eight Spec.	19 - 20	H.LS
HONDA			
	750 Shadow Aero	24 - 24	LS



HONDA			
	750 Shadow Phantom	24 - 24	LS
VT	750 C2S ABS	13 - 14	LS
VT	750 CS ABS	13 - 14	LS
CB	1300 R	02 - 04	LS
CB	1300 SF	98 - 00	LS
CB	1300 X-4	97 - 03	LS
KAWASAKI			
ZX-7RR	750 Ninja	96 - 02	LS
GTR	1400	07 - 16	LS
GTR	1400 ABS	07 - 16	LS
ZZR	1400	06 - 19	LS
ZZR	1400 ABS	06 - 19	LS
ZZR	1400 Performance Sport	17 - 19	LS



KAWASAKI			
ZZR	1400 SE	16 - 18	LS
MZ			
	1000 (MUZ) S	03 - 10	LS
	1000 (MUZ) SF	05 - 10	LS
	1000 (MUZ) SFX	07 - 07	LS
	1000 (MUZ) SN	05 - 05	LS
	1000 (MUZ) ST	07 - 10	LS

### SBS 716

### Recommended compound



POLARIS			
	250 2x4, 4x4	90 - 93	ATS
	250 Big Boss 4x6, 6x6	89 - 93	ATS
	250 Trail Blazer	90 - 07	ATS
	250 Trail Boss	91 - 99	ATS
	250 Trail Boss 2x4, 4x4	91 - 92	ATS
	250 Xplorer 4x4	00 - 02	ATS
	300 2x4, 4x4	94 - 95	ATS
	300 Big Boss 6x6	94 - 94	ATS
	300 Hawkeye 2x4, 4x4	07 - 11	ATS
	300 Xplorer 4x4	96 - 99	ATS
	300 Xpress 2x4	98 - 99	ATS
	300 Xpress L	96 - 97	ATS
	325 Magnum 2x4, 4x4	00 - 02	ATS
	325 Trail Boss	00 - 02	ATS
	330 ATP	04 - 06	ATS
	330 ATP	06 - 06	ATS
	330 Magnum 2x4, 4x4	03 - 13	ATS
	330 Trail Boss	03 - 14	ATS
	335 Sportsman 4x4	99 - 02	ATS
	350 Big Boss	93 - 93	ATS



POLARIS			
	350 L 2x4, 4x4	90 - 90	ATS
	350 L 4x4	93 - 93	ATS
	350 Sportsman 4x4	93 - 93	ATS
	350 Trail Boss 2x4, 4x4	88 - 89	ATS
	350 Trail Boss L 2x4	91 - 93	ATS
	350 Trail Boss L 4x4	91 - 91	ATS
	400 Big Boss L 6x6	96 - 96	ATS
	400 L 2x4	94 - 95	ATS
	400 L 4x4	94 - 94	ATS
	400 Scrambler 2x4, 4x4	00 - 03	ATS
	400 Scrambler 4x4	98 - 03	ATS
	400 Scrambler L 4x4	95 - 97	ATS
	400 Sport	99 - 00	ATS
	400 Sport L	94 - 98	ATS
	400 Sportsman	01 - 13	ATS
	400 Sportsman L 4x4	94 - 97	ATS
	400 Trail Blazer	03 - 04	ATS
	400 Xplorer L 4x4	95 - 02	ATS
	400 Xpress L	96 - 97	ATS



POLARIS			
	425 2x4, 4x4 Magnum	95 - 98	ATS
	425 Magnum 6x6	96 - 96	ATS
	425 Xpedition 4x4	00 - 03	ATS
	450 Sportsman	06 - 09	ATS
	455 Diesel EBS 4x4	99 - 01	ATS
	500 ATP HO	04 - 05	ATS
	500 Big Boss 6x6	98 - 99	ATS
	500 Magnum 2x4, 4x4	02 - 07	ATS
	500 Magnum 4x4	00 - 01	ATS
	500 Outlaw	06 - 09	ATS
	500 Predator	03 - 13	ATS
	500 Predator e	06 - 13	ATS
	500 Ranger 6x6	00 - 02	ATS
	500 Scrambler 2x4	01 - 02	ATS
	500 Scrambler 4x4	97 - 13	ATS
	500 Sportsman 4x4	96 - 14	ATS
	500 Sportsman 6x6	00 - 11	ATS
	500 Sportsman EBS 4x4	98 - 02	ATS
	500 Xplorer 4x4	97 - 97	ATS

### SBS 717

### Recommended compound



POLARIS			
	250 2x4, 4x4	90 - 93	ATS
	250 Big Boss 4x6, 6x6	89 - 93	ATS
	250 Big Boss 4x6, 6x6 Middle Axle Brake	89 - 93	ATS
	250 Trail Blazer	90 - 98	ATS
	250 Trail Boss	91 - 99	ATS
	250 Trail Boss 2x4, 4x4	91 - 92	ATS
	300 2x4, 4x4	94 - 95	ATS
	300 Big Boss 6x6	94 - 94	ATS
	300 Big Boss 6x6 Middle Axle Brake	94 - 94	ATS
	300 Xplorer 4x4	96 - 99	ATS
	300 Xpress 2x4	98 - 99	ATS
	300 Xpress L	96 - 97	ATS
	350 Big Boss	93 - 93	ATS
	350 Big Boss Middle Axle Brake	93 - 93	ATS



POLARIS			
	350 L 2x4, 4x4	90 - 90	ATS
	350 L 4x4	93 - 93	ATS
	350 Sportsman 4x4	93 - 93	ATS
	350 Trail Boss 2x4, 4x4	88 - 89	ATS
	350 Trail Boss L 2x4	91 - 93	ATS
	350 Trail Boss L 4x4	91 - 91	ATS
	400 Big Boss L 6x6	96 - 96	ATS
	400 L 2x4	94 - 95	ATS
	400 L 4x4	94 - 94	ATS
	400 Scrambler 4x4	98 - 98	ATS
	400 Scrambler L 4x4	95 - 97	ATS
	400 Sport L	94 - 98	ATS
	400 Sportsman L 4x4	94 - 97	ATS
	400 Xplorer L 4x4	95 - 99	ATS
	400 Xpress L	96 - 97	ATS
	425 2x4, 4x4 Magnum	95 - 98	ATS
	425 Magnum 6x6	96 - 96	ATS
	500 Big Boss 6x6	98 - 99	ATS



POLARIS			
	500 Big Boss 6x6 Middle Axle Brake	98 - 99	ATS
	500 Scrambler 4x4	97 - 97	ATS
	500 Sportsman 4x4	96 - 14	ATS
	500 Xplorer 4x4	97 - 97	ATS



STREET HF • HS • LS  
 AMERICAN H.HF • H.CT • H.HS • H.LS  
 SCOOTER HF • CT • MS

RACING  
 OFF ROAD  
 ATV

RST • DC • DCC • DS-1 • DS-2 • RQ  
 SI • RSI • CS  
 ATS • SI • RSI • PSI

Drawings 1:1

Available compounds HF • LS • RQ • H.HF • H.CT • H.LS

SBS 715

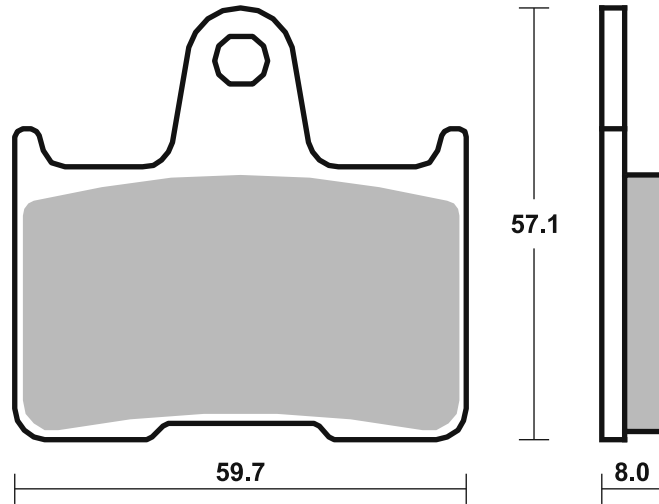

Available compounds HF • SI • RSI • ATS

SBS 716

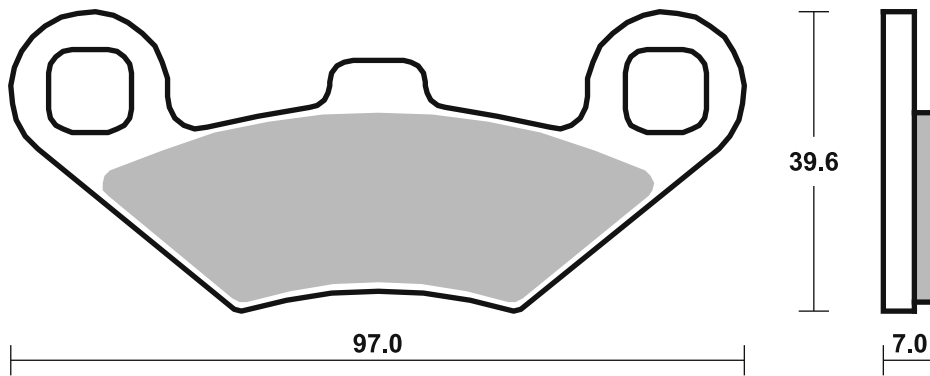

Available compounds HF • SI • RSI • ATS

SBS 717

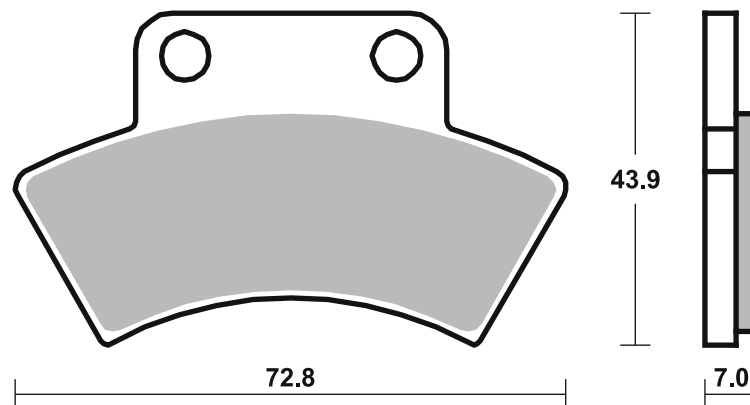

Applications

**SBS 718**

**Recommended compound**



**A.P. RACING CALIPERS**

CP-3548	

**SBS 719**

**Recommended compound**



**A.P. RACING CALIPERS**

CP-4226-2S0/3S0	

**SBS 720**

**Recommended compound**



**A.P. RACING CALIPERS**

CP-4484-2S0/3S0	

Brake Pad 1:1 Drawings, Compounds, Fitments

STREET HF • HS • LS  
AMERICAN H.HF • H.CT • H.HS • H.LS  
SCOOTER HF • CT • MS

RACING  
OFF ROAD  
ATV

RST • DC • DCC • DS-1 • DS-2 • RQ  
SI • RSI • CS  
ATS • SI • RSI • PSI

Drawings 1:1

Available compounds

HF • SI • RSI

SBS 718

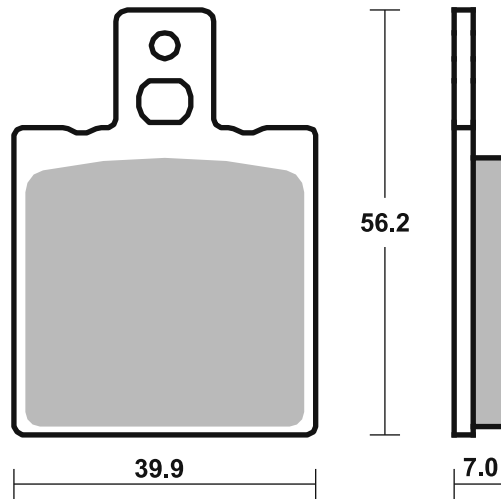

Available compounds

RST • RQ

SBS 719

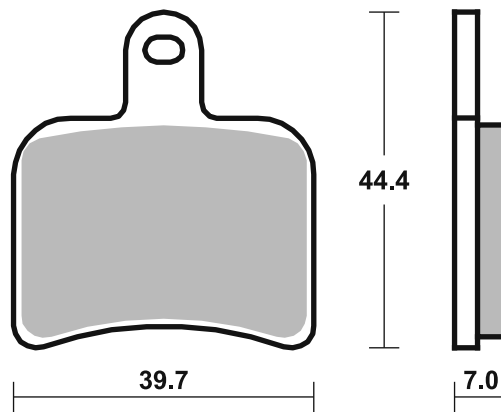

Available compounds

RQ

SBS 720

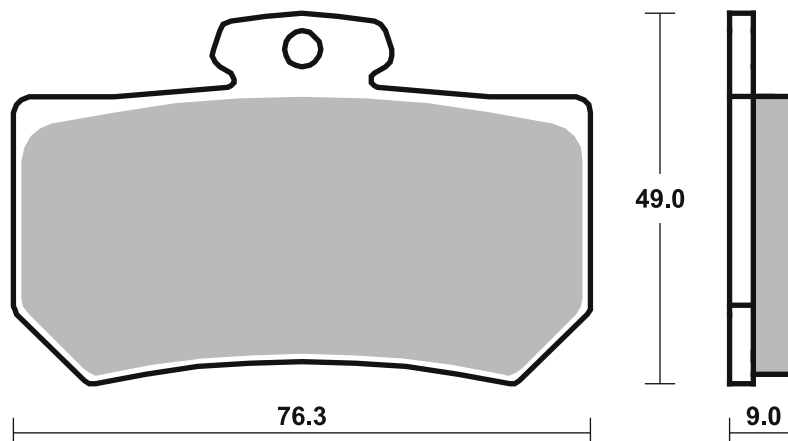



STREET  
AMERICAN  
SCOOTER

HF • HS • LS  
H.HF • H.CT • H.HS • H.LS  
HF • CT • MS

RACING  
OFF ROAD  
ATV

RST • DC • DCC • DS-1 • DS-2 • RQ  
SI • RSI • CS  
ATS • SI • RSI • PSI

Drawings 1:1

Available compounds

HF • HS

SBS 721

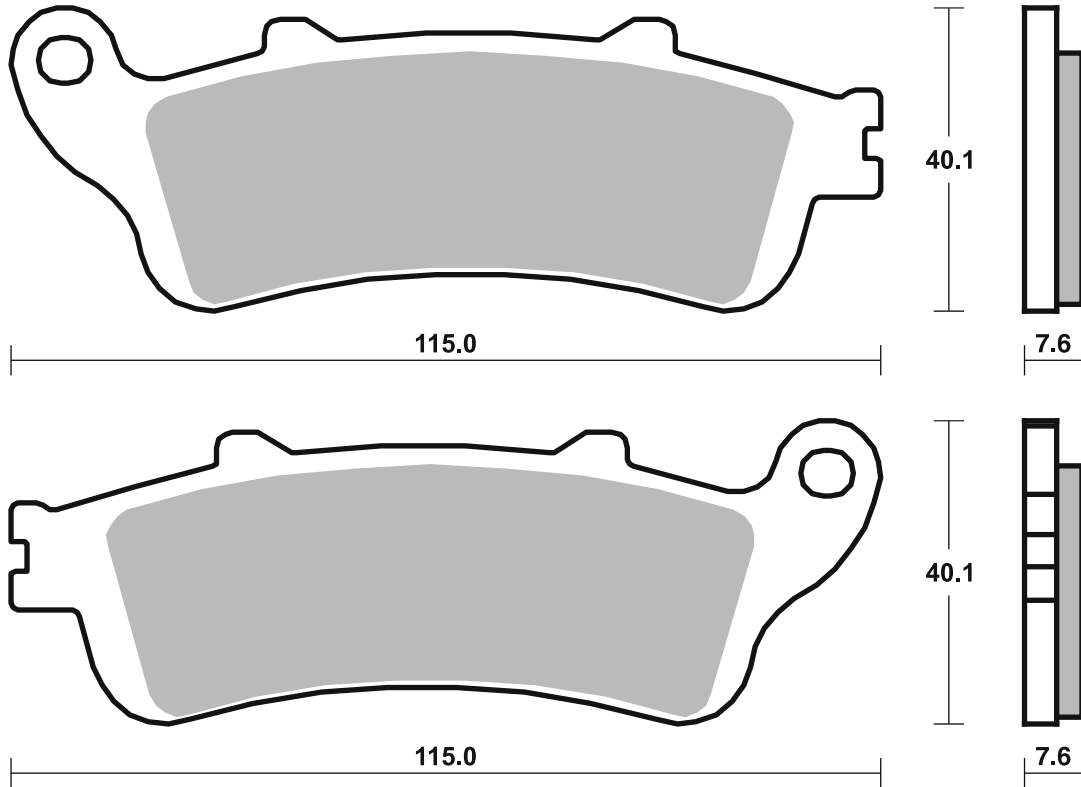

Available compounds

HF • LS

SBS 722

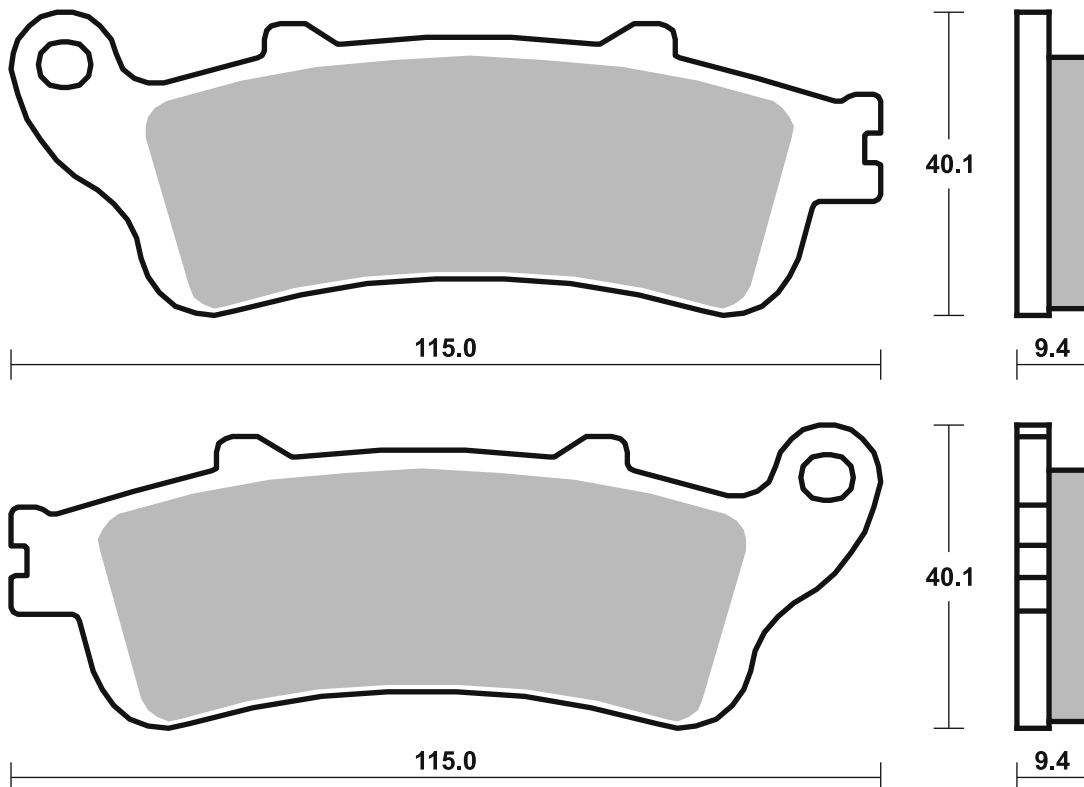

## Applications

### SBS 723

### Recommended compound



#### CAGIVA

125 Brillo	08 -08	HF

### SBS 726

### Recommended compound



#### KAWASAKI

KX 80	97 -00	RSI
KX 85	01 -24	RSI
KX 85 II	01 -24	RSI
KX 100	97 -21	RSI
KL 250 Super Sherpa	00 -02	SI

#### SUZUKI

RM 85	05 -24	RSI
RM 100	03 -03	RSI

Brake Pad 1:1 Drawings,  
Compounds, Fitments

STREET HF • HS • LS  
AMERICAN H.HF • H.CT • H.HS • H.LS  
SCOOTER HF • CT • MS

RACING  
OFF ROAD  
ATV

RST • DC • DCC • DS-1 • DS-2 • RQ  
SI • RSI • CS  
ATS • SI • RSI • PSI

Drawings 1:1

Available compounds

HF

SBS 723

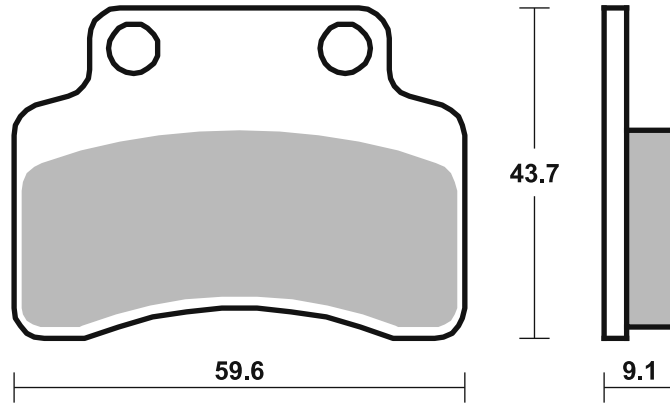

Available compounds

CS • SI • RSI

SBS 726

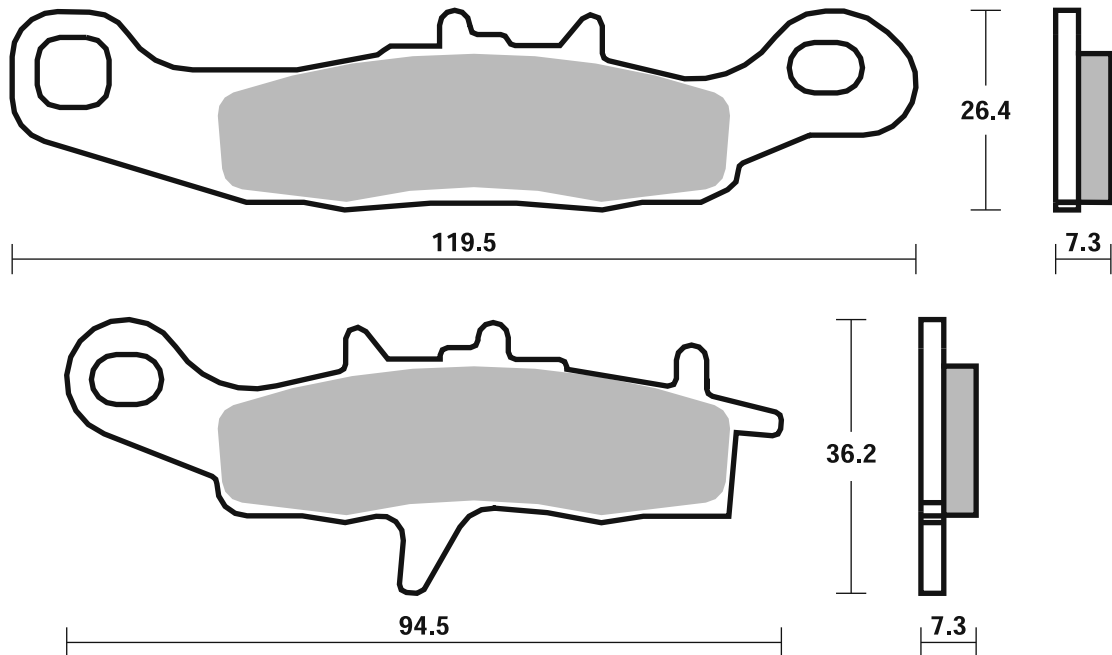

# Applications

## SBS 727

### Recommended compound



HONDA			
CB	400 Super Four S	97 - 02	HS

## SBS 728

### Recommended compound



YAMAHA			
TW	125	99 - 07	HF
DT	175	00 - 00	HF
TW	200	01 - 22	HF
	225 Bronco, Cellow	97 - 02	HF
XT	225	01 - 01	HF
XG	250 Tricker	05 - 11	HF
XT	250	08 - 22	HF
YZF	600 R6	99 - 02	LS
YZF	1000 R1	02 - 03	LS

## SBS 729

### Recommended compound



NISSIN			
6 Piston Racing Caliper			
<b>PERFORMANCE MACHINE</b>			
112 X 6B			
112 X 6QC			
YAMAHA			
YZF	750 R7 OW02		
	Race kit	99 - 01	HS

Brake Pad 1:1 Drawings, Compounds, Fitments



STREET HF • HS • LS  
AMERICAN H.HF • H.CT • H.HS • H.LS  
SCOOTER HF • CT • MS

RACING  
OFF ROAD  
ATV

RST • DC • DCC • DS-1 • DS-2 • RQ  
SI • RSI • CS  
ATS • SI • RSI • PSI

Drawings 1:1

Available compounds

HF • HS

SBS 727

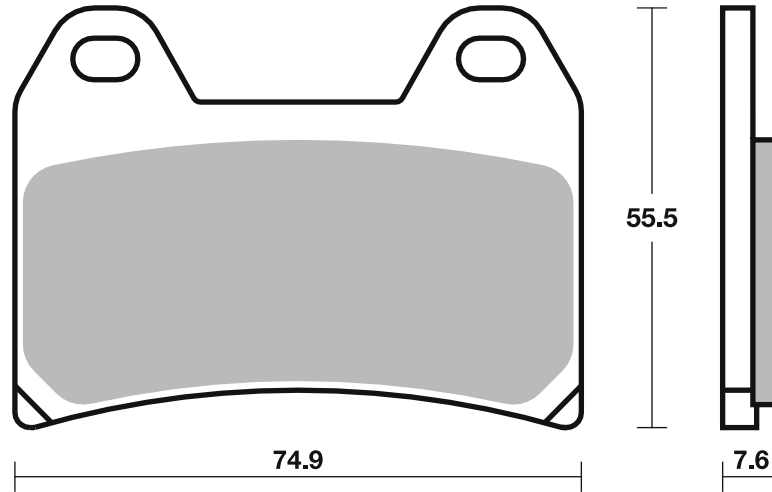

Available compounds

HF • LS • RQ

SBS 728

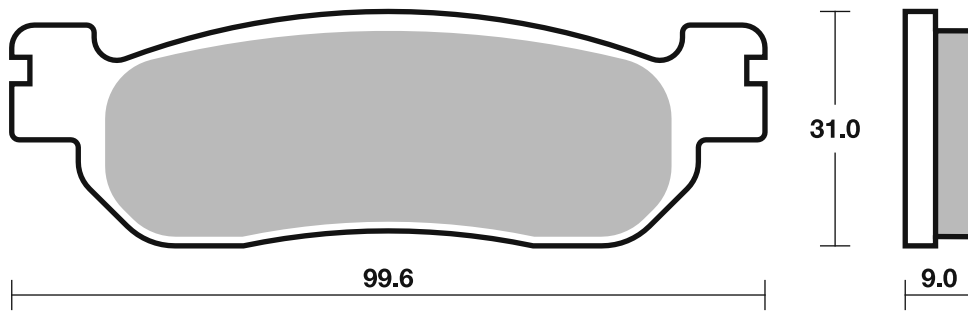

Available compounds

HF • HS • DC • H.HF • H.CT • H.HS

SBS 729

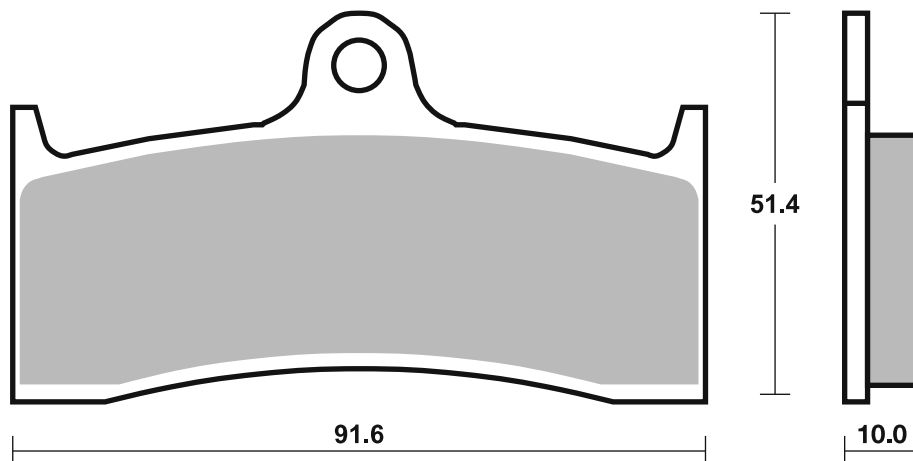



<b>APRILIA</b>			
RS	660 Tuono Factory	22 - 23	LS
RS	660	20 - 22	LS
RS	660 Extrem	23 - 23	LS
RS	660 Trofeo	22 - 22	LS
	1000 Blue Marlin	02 - 02	LS
	1000 Tuono	03 - 10	LS
ETV	1000 Caponord	01 - 08	LS
ETV	1000 Caponord Rally		
	Raid	04 - 08	LS
RSV	1000	97 - 03	LS
RSV	1000 Factory Pista	04 - 04	LS
RSV	1000 Falco SL, R	00 - 04	LS
RSV	1000 Nera	04 - 04	LS
RSV	1000 R	00 - 07	LS
RSV	1000 R Factory	04 - 08	LS
RSV	1000 SP	00 - 00	LS
RSV	1000 Tuono Fighter	03 - 05	LS
RSV	1000 Tuono R	03 - 03	LS
RSV	1000 Tuono R Factory,		
	ABS	06 - 12	LS
RSV	1000 Tuono R, ABS	04 - 12	LS
RSV	1000 Tuono V4 R	11 - 14	LS
RSV4	1000 ,ABS	09 - 13	LS
RSV4	1000 Factory	09 - 11	LS
RSV4	1000 Factory APRC ABS	13 - 16	LS
RSV4-R	1000 ,ABS APRC	10 - 10	LS
RSV4-RF	1000	15 - 20	LS
RSV4-RR	1000	15 - 20	LS
RSV	1100 Tuono V4	15 - 15	LS
RSV	1100 Tuono V4 Factory	15 - 18	LS
RSV	1100 Tuono V4 RR	15 - 19	LS
RSV4	1100 Factory	19 - 23	LS
<b>BENDA</b>			
LFS	700	23 - 23	LS
LFX	700	23 - 23	LS
<b>BENELLI</b>			
BN	302	14 - 14	LS
	500 C	19 - 19	LS
	500 Leoncino	16 - 17	LS
	502 C	23 - 24	LS
TRK	502	16 - 17	LS
BN	600	12 - 17	LS
BN	600 GT	14 - 15	LS
T	600 Tornado Naked	20 - 20	LS
	752 S	20 - 24	LS
	756 Cue	07 - 12	LS
	800 Leoncino	20 - 23	LS
	800 Leoncino Trail	22 - 23	LS
TRK	800	21 - 23	LS
	899 Trek	07 - 12	LS
TNT	899	07 - 15	LS
TNT	899 Century Racer	11 - 11	LS
	900 Tornado TRE	03 - 06	LS
	900 Tornado TRE RS	04 - 06	LS
TNT	1130	05 - 14	LS
TNT	1130 Cafe Racer	05 - 13	LS
TNT	1130 Century Racer	11 - 12	LS
TNT	1130 Officine	07 - 07	LS
TNT	1130 R	17 - 17	LS
TNT	1130 Sport	05 - 08	LS
TNT	1130 Titanium	05 - 08	LS
TNT	1130 Trek	06 - 12	LS
TNT	1130 Trek Amazonas	07 - 15	LS
<b>BIMOTA</b>			
3D	800 Tesi	16 - 16	LS
	1000 Tera	24 - 24	LS
	1000 Tesi H2	21 - 23	LS



<b>BIMOTA</b>			
BB3	1000	14 - 18	LS
DB5	1000	05 - 11	LS
DB5	1000 S	07 - 11	LS
DB6	1000 Delirio	07 - 09	LS
KB4	1000	23 - 23	LS
KB4	1000 RC	23 - 23	LS
DB10	1078 Bimotard	12 - 12	LS
DB5	1078 RE	12 - 12	LS
DB7	1098	08 - 08	LS
3D	1100 Tesi	07 - 11	LS
DB6R	1100 Delirio	08 - 09	LS
DB8	1198	10 - 14	LS
	1200 Impeto	16 - 17	LS
DB11	1200 VLX	13 - 13	LS
DB12	1200	12 - 12	LS
DB9	1200 Brivido	12 - 18	LS
<b>BOMBARDIER</b>			
	500 Traxter 4x4	99 - 00	HF HF
<b>BRAMMO</b>			
	Empulse	14 - 16	LS
<b>BREMO RACING CALIPERS</b>			
	Goldline 20.6951.50, road		
	Supersport 120A44110, P2 34		
<b>CAGIVA</b>			
	650 Raptor	01 - 08	LS
	650 V-Raptor	01 - 08	LS
	1000 Raptor	00 - 08	LS
	1000 V-Raptor	00 - 08	LS
	1000 X3 Raptor	04 - 04	LS
	1000 X-Raptor	03 - 04	LS
	1000 Xtra Raptor	02 - 06	LS
<b>CF MOTO</b>			
	125 NK	24 - 24	LS
	400 SR S	24 - 24	LS
	700 CL-X Spirit	24 - 24	LS
	700 CL-X Sport	22 - 22	LS
	800 NK GP	24 - 24	LS
<b>CF MOTO ZEEHO</b>			
	AE8	22 - 23	LS
<b>DERBI</b>			
GPR	50 Nude	04 - 10	HF
GPR	50 Racing	04 - 13	HF
GP1	125	05 - 06	HF
GP1	250	05 - 09	HF
	659 Mulhacen	05 - 07	LS
	659 Mulhacen Cafe	08 - 08	LS
<b>DUCATI</b>			
	620 Multistrada	05 - 06	LS
	620 Multistrada Dark	05 - 06	LS
	620 Sport	03 - 06	LS
	696 Monster	08 - 12	LS
	749 , S	03 - 07	LS
	749 R	04 - 07	LS
	750 Sport	00 - 02	LS
	750 Super Sport	00 - 02	LS
	795 Monster	12 - 12	LS
	796 Hypermotard	10 - 12	LS
	796 Monster	11 - 14	LS
	796 Monster ABS	11 - 14	LS
	800 Sport	03 - 06	LS
	800 Supersport	03 - 06	LS
	821 Hypermotard	13 - 16	LS



<b>DUCATI</b>			
	821 Hypermotard ABS	13 - 16	LS
	821 Hypermotard SP	13 - 16	LS
	821 Hypermotard SP		
	ABS	13 - 16	LS
	821 Hyperstrada	13 - 16	LS
	821 Hyperstrada ABS	13 - 16	LS
	821 Monster	14 - 21	LS
	821 Monster Dark	15 - 16	LS
	821 Monster Stealth	19 - 21	LS
	848	08 - 10	LS
	848 EVO	11 - 12	LS
	848 Streetfighter	12 - 15	LS
	848 Streetfighter S	12 - 15	LS
	899 Panigale	14 - 15	LS
	900 Super Sport	98 - 02	LS
	916 Sport Touring 4	99 - 01	LS
	937 Monster	20 - 24	LS
	937 Monster +	20 - 24	LS
	937 Monster SP	23 - 24	LS
	939 Hypermotard	16 - 18	LS
	939 Hypermotard SP	16 - 18	LS
	939 Hyperstrada	16 - 16	LS
	939 SuperSport	17 - 20	LS
	939 SuperSport S	17 - 20	LS
	944 Sport Touring	98 - 03	LS
	944 ST2	97 - 03	LS
	950 Hypermotard	19 - 24	LS
	950 Hypermotard RVE	20 - 24	LS
	950 Hypermotard SP	19 - 24	LS
	950 Supersport	20 - 24	LS
	950 SuperSport S	20 - 24	LS
	955 Panigale V2	20 - 24	LS
	955 Panigale V2		
	Bayliss	22 - 24	LS
	955 Streetfighter V2	22 - 24	LS
	959 Panigale	16 - 20	LS
	959 Panigale Corse	18 - 20	LS
D16RR	990 Desmosedici RR	07 - 08	LS
	992 ST3	04 - 07	LS
	992 ST3s ABS	06 - 07	LS
	996 ST4s	02 - 06	LS
	996 ST4s ABS	03 - 06	LS
	998 Monster S4Rs	06 - 06	LS
	998 Superleggera V4	20 - 24	LS
	999	03 - 07	LS
	999 Monster S4R	07 - 08	LS
	999 Monster S4RS	07 - 08	LS
	999 R	03 - 07	LS
	999 RS (slipper clutch)	04 - 05	LS
	999 S	03 - 07	LS
	1000 Hypermotard	06 - 06	LS
	1000 Monster S2R	06 - 07	LS
	1000 Multistrada	07 - 07	LS
	1000 Multistrada DS	03 - 06	LS
	1000 Multistrada S DS	05 - 06	LS
	1000 Panigale V4 R	19 - 24	LS
	1000 Supersport DS	03 - 06	LS
	1098	07 - 08	LS
	1098 R	08 - 10	LS
	1098 R Bayliss LE	09 - 10	LS
	1098 S	07 - 08	LS
	1098 Streetfighter	09 - 14	LS
	1098 Streetfighter S	09 - 13	LS
	1100 Hypermotard	07 - 09	LS
	1100 Hypermotard EVO	10 - 12	LS
	1100 Hypermotard EVO		
	SP	10 - 12	LS
	1100 Hypermotard S	07 - 09	LS
	1100 Monster	09 - 13	LS
	1100 Monster ABS	09 - 10	LS

STREET HF • HS • LS  
AMERICAN H.HF • H.CT • H.HS • H.LS  
SCOOTER HF • CT • MS

RACING  
OFF ROAD  
ATV

RST • DC • DCC • DS-1 • DS-2 • RQ  
SI • RSI • CS  
ATS • SI • RSI • PSI

Drawings 1:1

Available compounds

HF • LS • RQ

SBS 730

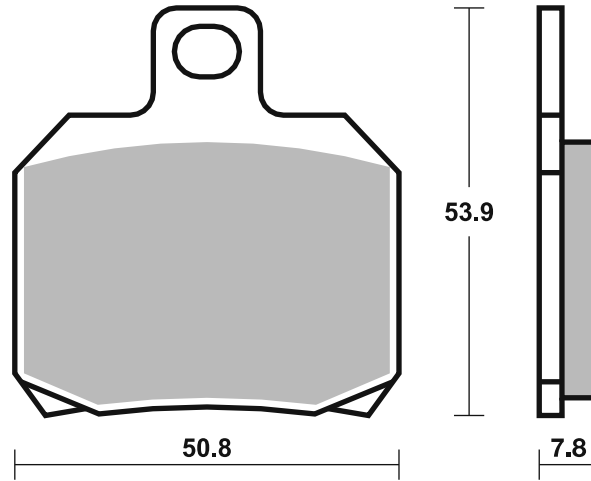

Brake Pad 1:1 Drawings,  
Compounds, Fitments



<b>DUCATI</b>			
1100 Monster EVO	11 - 13		<b>LS</b>
1100 Monster EVO			
ABS	11 - 13		<b>LS</b>
1100 Monster S	09 - 13		<b>LS</b>
1100 Monster S ABS	09 - 10		<b>LS</b>
1100 Multistrada	07 - 09		<b>LS</b>
1100 Multistrada S	07 - 09		<b>LS</b>
1103 Panigale V4	18 - 24		<b>LS</b>
1103 Panigale V4 SP	21 - 21		<b>LS</b>
1103 Panigale V4 SP2	22 - 24		<b>LS</b>
1103 Panigale V4			
Speciale	18 - 19		<b>LS</b>
1103 Panigale V4S	18 - 24		<b>LS</b>
1103 Panigale V4S			
Corse	19 - 19		<b>LS</b>
1103 Streetfighter V4	20 - 24		<b>LS</b>
1103 Streetfighter V4			
Lamborghini	20 - 24		<b>LS</b>
1103 Streetfighter V4			
SP	22 - 23		<b>LS</b>
1103 Streetfighter V4			
SP2	23 - 24		<b>LS</b>
1103 Streetfighter V4S	20 - 24		<b>LS</b>
1198	09 - 13		<b>LS</b>
1198 S	09 - 12		<b>LS</b>
1198 SP	11 - 12		<b>LS</b>
1199 Panigale	12 - 14		<b>LS</b>
1199 Panigale R	13 - 15		<b>LS</b>
1199 Panigale S	12 - 14		<b>LS</b>
1199 Superleggera	14 - 14		<b>LS</b>
1200 Monster	14 - 21		<b>LS</b>
1200 Monster 25			
Anniversario	19 - 19		<b>LS</b>
1200 Monster R	16 - 19		<b>LS</b>
1200 Monster S	14 - 21		<b>LS</b>
1200 Monster S Stripe	15 - 17		<b>LS</b>
1200 Multistrada	10 - 14		<b>LS</b>
1200 Multistrada S GT	12 - 14		<b>LS</b>
1200 Multistrada S			
Pikes Peak	11 - 14		<b>LS</b>
1200 Multistrada S			
Sport	10 - 14		<b>LS</b>
1200 Multistrada S			
Touring	10 - 14		<b>LS</b>
1200 Multistrada			
Touring ABS	10 - 14		<b>LS</b>
1299 Panigale	15 - 17		<b>LS</b>
1299 Panigale R	15 - 17		<b>LS</b>
1299 Panigale R Final			
Edition	17 - 20		<b>LS</b>
1299 Panigale S	15 - 17		<b>LS</b>
1299 Panigale S			
Anniversario	17 - 17		<b>LS</b>
1299 Superleggera	17 - 17		<b>LS</b>
<b>ENERGICA</b>			
Ego	15 - 21		<b>LS</b>
Eva EsseEsse9	18 - 23		<b>LS</b>
Eva Ribelle	15 - 21		<b>LS</b>
Experia	23 - 23		<b>LS</b>
<b>FANTIC</b>			
700 Caballero			
Scrambler	23 - 23		<b>LS</b>
<b>GALESPEED</b>			
2 Piston Axial Rear Caliper, GSRCA34AF			
2 Piston Axial Rear Caliper, GSRCA34AT			

<b>GALESPEED</b>			
2 Piston Radial Rear Caliper, GSRCA30F (30 mm Piston)			
2 Piston Radial Rear Caliper, GSRCA30T (30 mm Piston)			
2 Piston Radial Rear Caliper, GSRCA34F (34 mm Piston)			
2 Piston Radial Rear Caliper, GSRCA34T (34 mm Piston)			
<b>GILERA</b>			
600 Supersport	02 - 02		<b>LS</b>
<b>HARLEY DAVIDSON</b>			
Livewire	19 - 24		<b>LS</b>
<b>HONDA</b>			
CBR 1000 RR-R Fireblade	20 - 24		<b>LS</b>
CBR 1000 RR-R SP			
Fireblade	20 - 24		<b>LS</b>
RC213V-S 1000	16 - 18		<b>LS</b>
<b>HOREX</b>			
VR6 1200 Cafe Racer	17 - 23		<b>LS</b>
VR6 1200 Classic	17 - 23		<b>LS</b>
VR6 1200 Raw	23 - 23		<b>LS</b>
<b>INDIAN</b>			
FTR 1200	19 - 23		<b>LS</b>
FTR 1200 R carbon	21 - 23		<b>LS</b>
FTR 1200 Rally	19 - 23		<b>LS</b>
FTR 1200 S	19 - 23		<b>LS</b>
FTR 1200 S RR	20 - 23		<b>LS</b>
<b>ITALJET</b>			
500 Dragster	23 - 23		<b>LS</b>
<b>KAWASAKI</b>			
ZX 1000 H2 Carbon Ninja	17 - 20		<b>LS</b>
ZX 1000 H2 Ninja	15 - 21		<b>LS</b>
ZX 1000 H2R Ninja	15 - 24		<b>LS</b>
<b>KTM</b>			
RC8 890 C	22 - 22		<b>LS</b>
RC8 1190	08 - 11		<b>LS</b>
RC8 1190 R	09 - 15		<b>LS</b>
RC8 1190 R Track	11 - 15		<b>LS</b>
1290 Super Duke GT	16 - 20		<b>LS</b>
1290 Super Duke R	14 - 22		<b>LS</b>
1290 Super Duke R			
EVO	22 - 22		<b>LS</b>
1290 Superduke R			
Black	20 - 20		<b>LS</b>
<b>LAVERDA</b>			
TTS 800	99 - 99		<b>HF</b>
SFC 1000	04 - 04		<b>LS</b>
<b>LIVEWIRE</b>			
ONE	19 - 24		<b>LS</b>
<b>MONDIAL</b>			
1000 EVO	04 - 04		<b>LS</b>
1000 Piega	03 - 04		<b>LS</b>
1000 RZ Nuda	04 - 04		<b>LS</b>
1000 Starfighter	04 - 04		<b>LS</b>
<b>MOTO-GUZZI</b>			
750 Brevia	03 - 09		<b>LS</b>
750 Nevada Classic			
ie	06 - 11		<b>HF</b>

<b>MOTO-GUZZI</b>			
750 Nevada, Nevada			
Club	03 - 16		<b>HF</b>
V7 750 Cafe Classic	10 - 13		<b>LS</b>
V7 750 Classic	09 - 12		<b>LS</b>
V7 750 Clubman Racer	10 - 10		<b>LS</b>
V7 750 Racer	11 - 11		<b>LS</b>
850 Brevia	06 - 09		<b>LS</b>
V 1100 Brevia	04 - 04		<b>LS</b>
1200 MGS-01 Corsa	05 - 13		<b>LS</b>
1200 Sport 4V	09 - 11		<b>LS</b>
<b>MOTO-MORINI</b>			
649 X-Cape	20 - 23		<b>LS</b>
750 Corsaro	24 - 24		<b>LS</b>
750 Corsaro Sport	24 - 24		<b>LS</b>
1200 11 1/2	18 - 18		<b>LS</b>
1200 9 1/2	06 - 09		<b>LS</b>
1200 Corsaro	06 - 13		<b>LS</b>
1200 Corsaro ZT	20 - 20		<b>LS</b>
1200 Corsaro ZZ	18 - 20		<b>LS</b>
1200 Milano	18 - 24		<b>LS</b>
1200 Scrambler	18 - 18		<b>LS</b>
1200 Sport	08 - 13		<b>LS</b>
1200 Super Scrambler	20 - 20		<b>LS</b>
1200 X-Cape	24 - 24		<b>LS</b>
<b>MV AGUSTA</b>			
675 Brutale	12 - 15		<b>LS</b>
F3 675	13 - 20		<b>LS</b>
F3 675 RC	16 - 20		<b>LS</b>
800 Brutale	13 - 20		<b>LS</b>
800 Brutale Dragster	15 - 19		<b>LS</b>
800 Brutale Dragster			
RC	17 - 20		<b>LS</b>
800 Brutale Dragster			
RR	15 - 19		<b>LS</b>
800 Brutale Dragster			
RR LH44	18 - 20		<b>LS</b>
800 Brutale Dragster			
RR Pirelli	18 - 20		<b>LS</b>
800 Brutale RC	18 - 20		<b>LS</b>
800 Brutale Rosso	20 - 21		<b>LS</b>
800 Brutale RR	16 - 20		<b>LS</b>
800 Dragster Rosso	20 - 21		<b>LS</b>
800 Rivale	13 - 17		<b>LS</b>
800 RVS#1	18 - 20		<b>LS</b>
800 Stradale	15 - 16		<b>LS</b>
800 Superverloce	19 - 22		<b>LS</b>
800 Turismo Veloce	14 - 19		<b>LS</b>
800 Turismo Veloce			
Lusso	14 - 20		<b>LS</b>
800 Turismo Veloce			
Lusso Scs	18 - 21		<b>LS</b>
800 Turismo Veloce			
RC	17 - 20		<b>LS</b>
800 Turismo Veloce			
Rosso	20 - 21		<b>LS</b>
F3 800 AMG GT	16 - 20		<b>LS</b>
F3 800 RC	16 - 20		<b>LS</b>
F3 800 RR	21 - 23		<b>LS</b>
950 9.5 LXP Orioli	24 - 24		<b>LS</b>
1000 Brutale RR	20 - 20		<b>LS</b>
1000 Rush	20 - 20		<b>LS</b>
<b>NIU</b>			
RQi	24 - 24		<b>LS</b>
<b>NORTON</b>			
961 Commando			
Cafe Racer	11 - 14		<b>LS</b>

STREET HF • HS • LS  
AMERICAN H.HF • H.CT • H.HS • H.LS  
SCOOTER HF • CT • MS

RACING  
OFF ROAD  
ATV

RST • DC • DCC • DS-1 • DS-2 • RQ  
SI • RSI • CS  
ATS • SI • RSI • PSI

Drawings 1:1

Available compounds

HF • LS • RQ

SBS 730

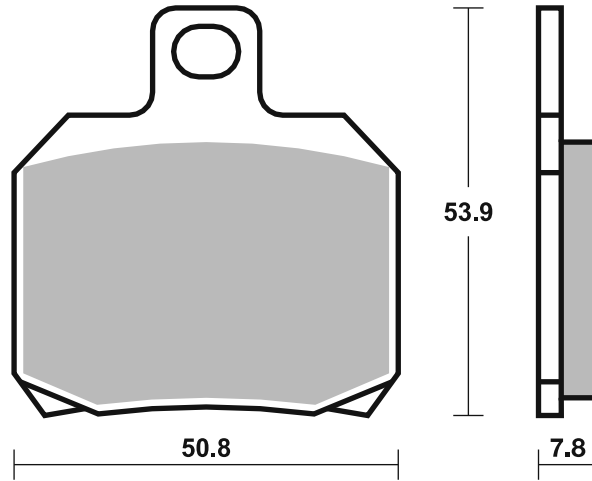



STREET HF • HS • LS  
AMERICAN H.HF • H.CT • H.HS • H.LS  
SCOOTER HF • CT • MS

RACING  
OFF ROAD  
ATV

RST • DC • DCC • DS-1 • DS-2 • RQ  
SI • RSI • CS  
ATS • SI • RSI • PSI

Drawings 1:1

Available compounds

HF • LS • RQ

SBS 730

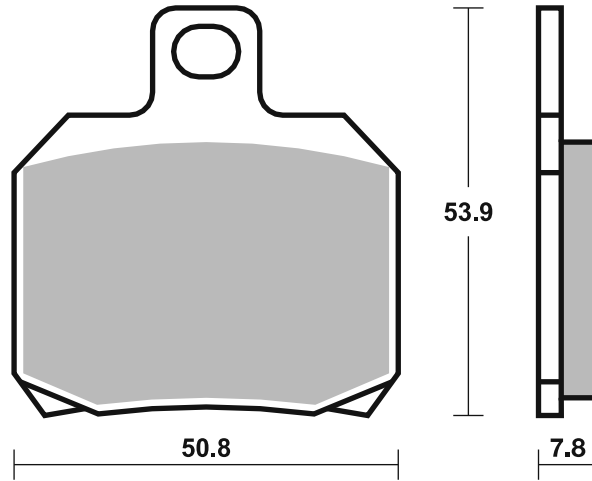

Available compounds

RQ

SBS 732

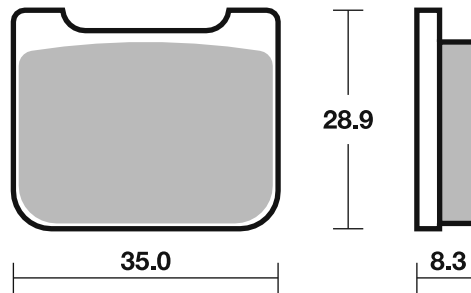





STREET HF • HS • LS  
 AMERICAN H.HF • H.CT • H.HS • H.LS  
 SCOOTER HF • CT • MS

RACING  
 OFF ROAD  
 ATV

RST • DC • DCC • DS-1 • DS-2 • RQ  
 SI • RSI • CS  
 ATS • SI • RSI • PSI

Drawings 1:1

Available compounds

HF • LS • RQ

SBS 733

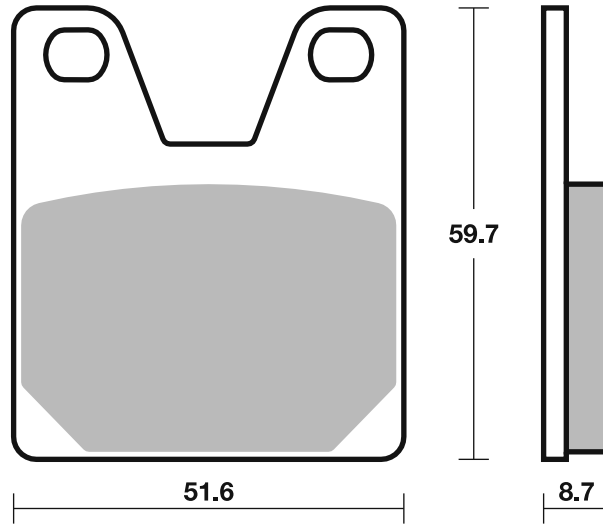

Available compounds

HF • HS • DC • RST

SBS 734

HF / HS - Th. 7.2  
 RST / DC - Th. 8.0

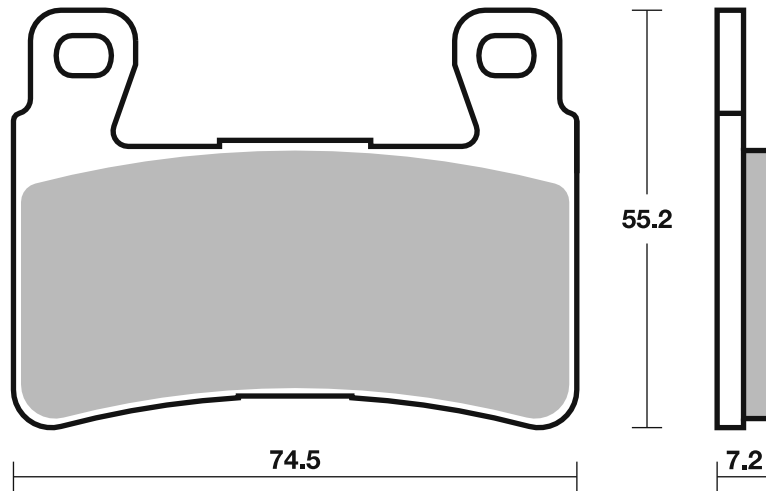

## Applications

### SBS 735

### Recommended compound



<b>HONDA</b>			
NT	650 V Deauville	02 - 05	<b>HS</b>
VFR	800 FI	98 - 01	<b>HS</b>
VFR	800 V-TEC, ABS	02 - 05	<b>HS</b>
XL	1000 Varadero	99 - 99	<b>HS</b>
XL	1000 Varadero (Linked brake system)	00 - 06	<b>HS</b>
CB	1100 Hornet	99 - 99	<b>HS</b>
CB	1100 X-11	00 - 03	<b>HS</b>
CBR	1100 XX Super Blackbird	96 - 07	<b>HS</b>
ST	1300 Pan European, ABS	02 - 07	<b>HS</b>
GL	1800 Gold Wing	01 - 17	<b>HS</b>
GL	1800 Gold Wing F6B	13 - 16	<b>HS</b>
VTX	1800	01 - 12	<b>HS</b>
<b>KAWASAKI</b>			
EN	650 Vulcan S	15 - 24	<b>HS</b>
EN	650 Vulcan S Cafe	17 - 19	<b>HS</b>
EN	650 Vulcan S SE	17 - 18	<b>HS</b>
<b>VICTORY</b>			
	1731 Vision all models	08 - 17	<b>H.HS</b>

### SBS 736

### Recommended compound



<b>HONDA</b>			
NT	650 V Deauville	02 - 05	<b>LS</b>
NT	700 Deauville ABS	06 - 12	<b>LS</b>
NT	700 V Varadero, ABS	10 - 13	<b>LS</b>
VFR	800	06 - 13	<b>LS</b>
VFR	800 ABS	06 - 13	<b>LS</b>
VFR	800 FI	98 - 01	<b>LS</b>
VFR	800 V-TEC, ABS	02 - 05	<b>LS</b>
XL	1000 Varadero	99 - 99	<b>LS</b>
XL	1000 Varadero	07 - 13	<b>LS</b>
XL	1000 Varadero (Linked brake system)	00 - 06	<b>LS</b>
XL	1000 Varadero ABS	04 - 13	<b>LS</b>
CB	1100 Hornet	99 - 99	<b>LS</b>
CB	1100 X-11	00 - 03	<b>LS</b>
CBR	1100 XX Super Blackbird	96 - 07	<b>LS</b>
VT	1300 CXA A Fury ABS	10 - 22	<b>LS</b>
VTX	1800	01 - 12	<b>LS</b>

STREET  
AMERICAN  
SCOOTER

HF • HS • LS • SP  
H.HF • H.CT • H.HS • H.LS  
HF • CT • MS

RACING  
OFF ROAD  
ATV

RS • DC • DCC • DS-1 • DS-2 • RQ  
SI • RSI • CS  
ATS • SI • RSI • PSI

Drawings 1:1

Available compounds **HF • HS • H.HF • H.CT • H.HS**

**SBS 735**

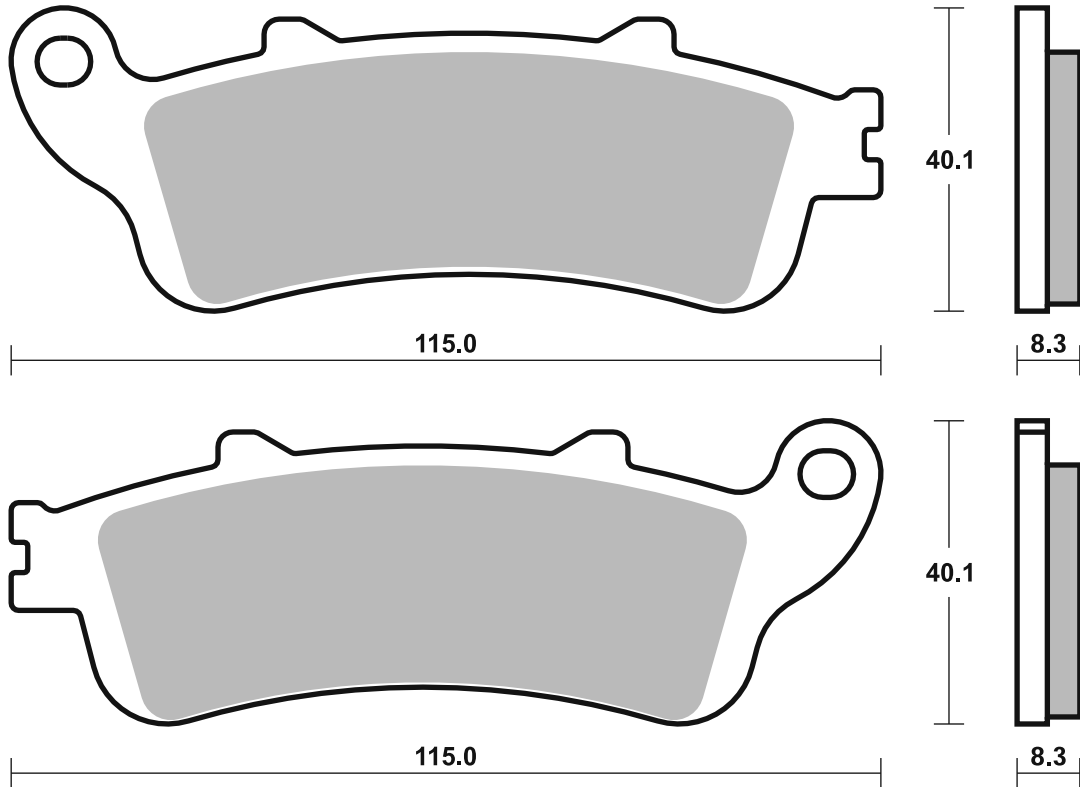

Available compounds **HF • LS**

**SBS 736**

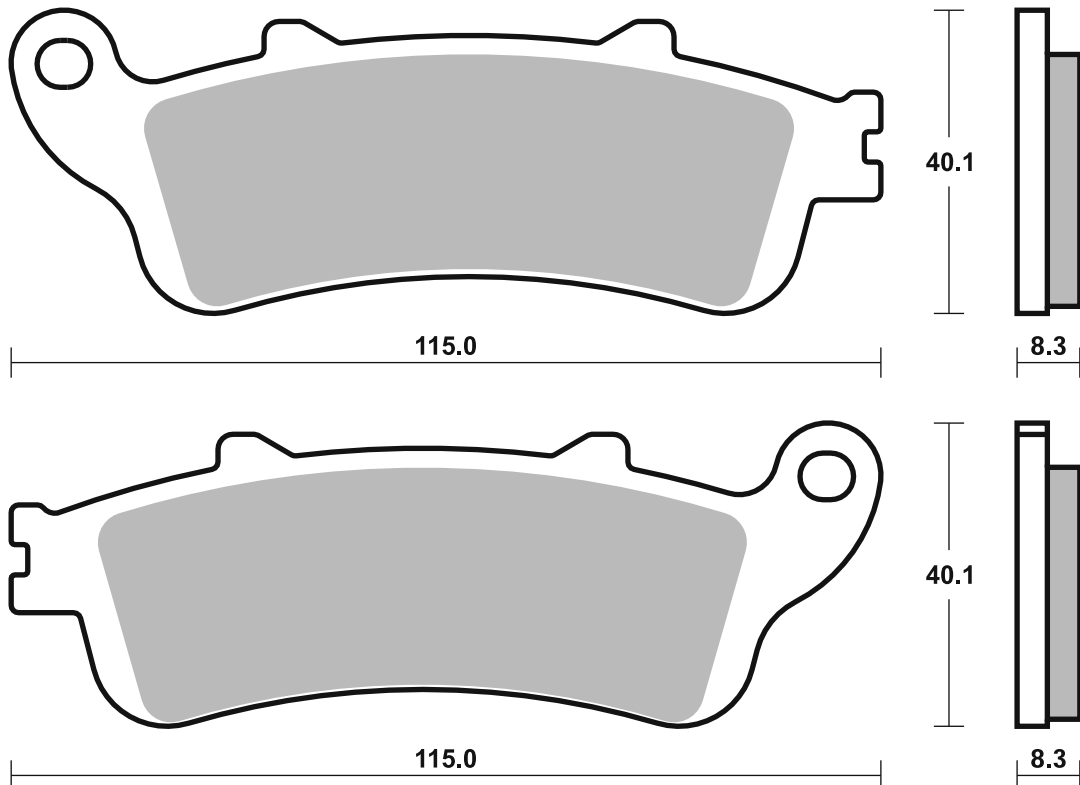

Applications

**SBS 737**

Recommended compound



**HARRISON/BILLET CALIPERS**

4 Piston Billet  
Big-6

**SBS 739**

Recommended compound



**EXCELSIOR-HENDERSON**

1386 Deadwood			
Special	00 - 00	H.HS	H.LS
1386 Super X			
all models	99 - 99	H.HS	H.LS

**SBS 740**

Recommended compound



**TRIUMPH**

1200 Trophy SE	13 - 18	HS	
----------------	---------	----	--

**YAMAHA**

FJR 1300 A	13 - 20	HS	
FJR 1300 ABS	06 - 12	HS	
FJR 1300 AE	16 - 19	HS	
FJR 1300 AS	13 - 19	HS	
XV 1900 A	11 - 11	HS	

Brake Pad 1:1 Drawings,  
Compounds, Fitments

STREET HF • HS • LS  
 AMERICAN H.HF • H.CT • H.HS • H.LS  
 SCOOTER HF • CT • MS

RACING  
 OFF ROAD  
 ATV

RST • DC • DCC • DS-1 • DS-2 • RQ  
 SI • RSI • CS  
 ATS • SI • RSI • PSI

Drawings 1:1

Available compounds

HF • H.HF • H.CT

SBS 737

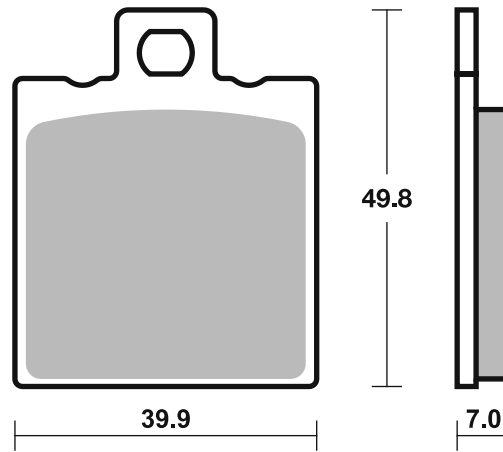

Available compounds

H.HS • H.LS

SBS 739

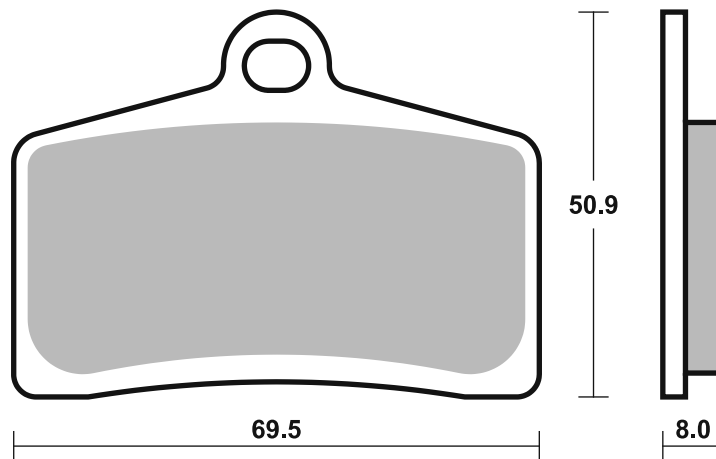

Available compounds

HF • HS

SBS 740

1 set = 4 pcs.

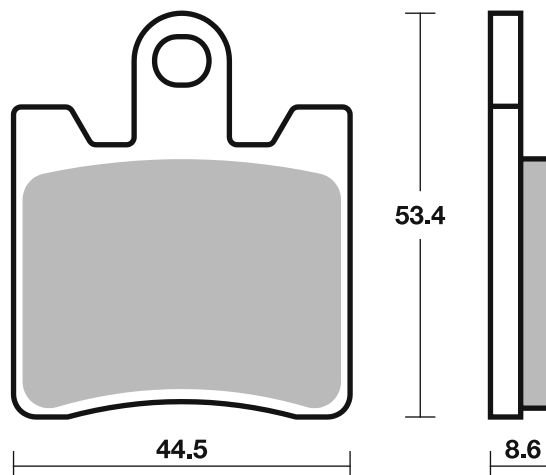



STREET HF • HS • LS  
 AMERICAN H.HF • H.CT • H.HS • H.LS  
 SCOOTER HF • CT • MS

RACING  
 OFF ROAD  
 ATV

RST • DC • DCC • DS-1 • DS-2 • RQ  
 SI • RSI • CS  
 ATS • SI • RSI • PSI

Drawings 1:1

Available compounds **HF • LS • RQ**

**SBS 742**

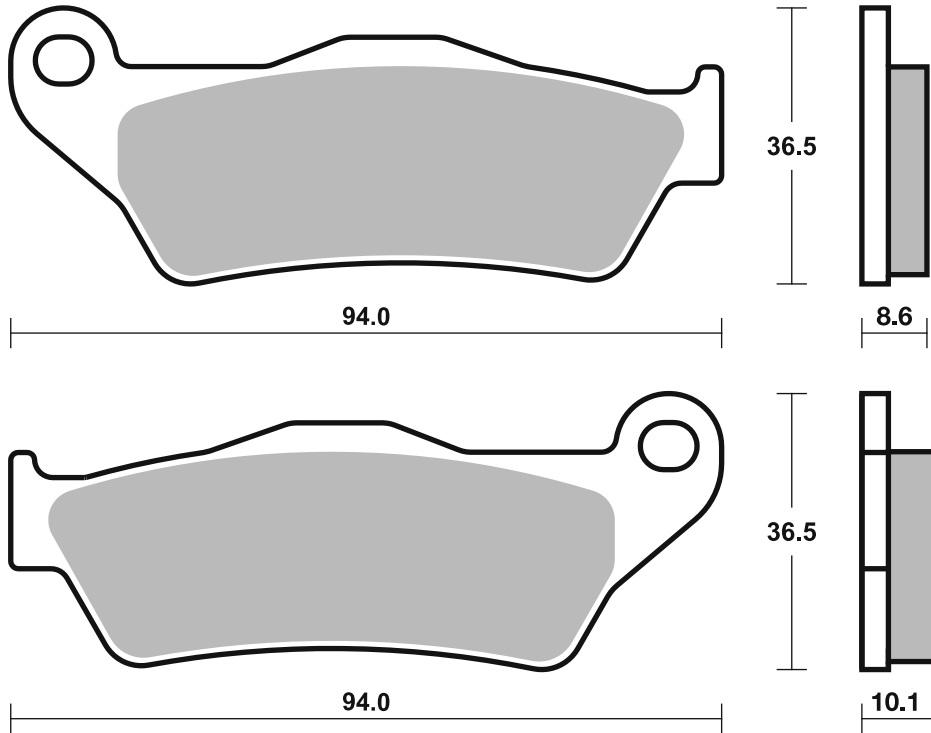

Available compounds **HF • HS**

**SBS 743**

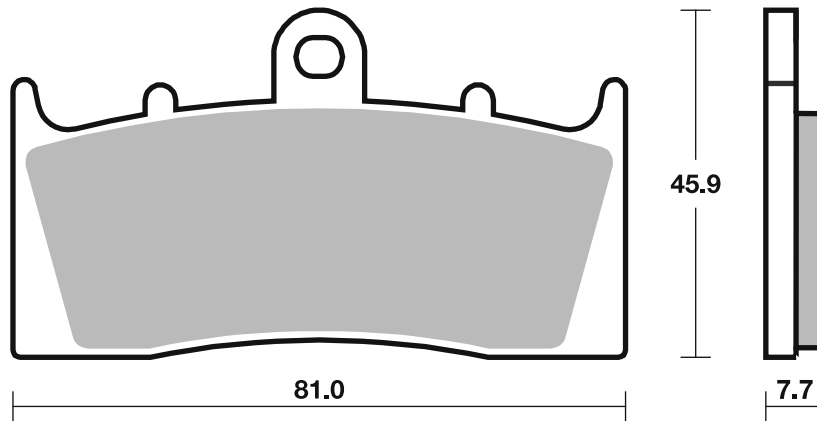

**SBS 746 Recommended compound**



BMW			
K	1200 LT	99 - 00	HF
K	1200 LT With		
	Integral ABS	01 - 08	HF
R	1200 CL	03 - 04	HF

**SBS 747 Recommended compound**



APRILIA			
RS	125	06 - 12	HF
HYOSUNG			
GD	250 EXIV-R	15 - 17	HF
GT	250 iR	15 - 15	HF
GT	300 R	16 - 17	HF
GT	650 iR	15 - 15	HF

Brake Pad 1:1 Drawings,  
Compounds, Fitments



STREET  
AMERICAN  
SCOOTER

HF • HS • LS  
H.HF • H.CT • H.HS • H.LS  
HF • CT • MS

RACING  
OFF ROAD  
ATV

RST • DC • DCC • DS-1 • DS-2 • RQ  
SI • RSI • CS  
ATS • SI • RSI • PSI

Drawings 1:1

Available compounds

HF

SBS 746

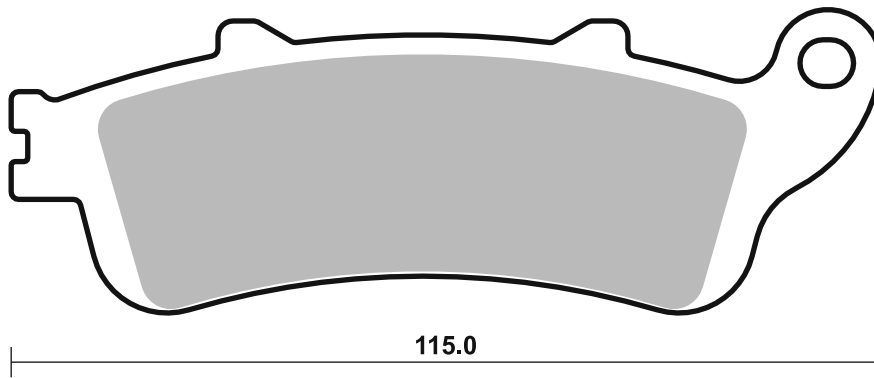
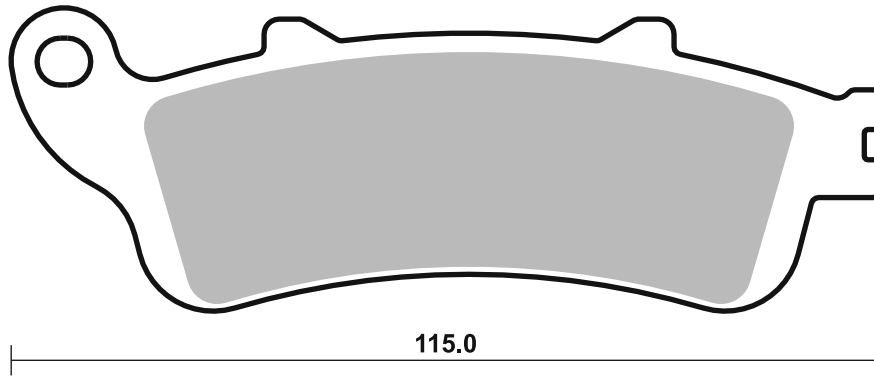

Available compounds

HF • RQ

SBS 747

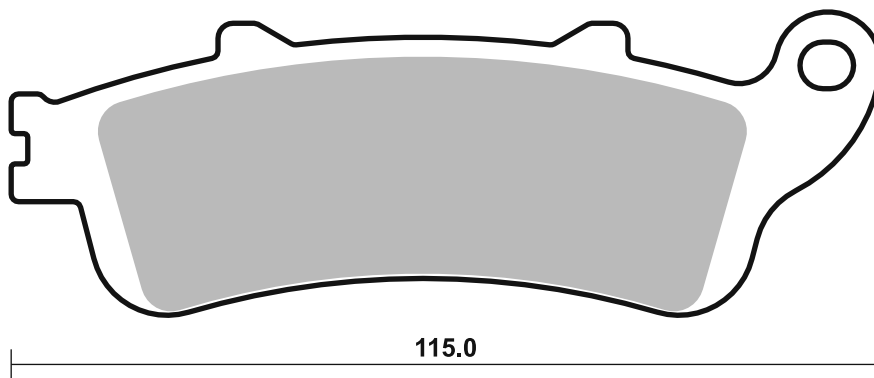
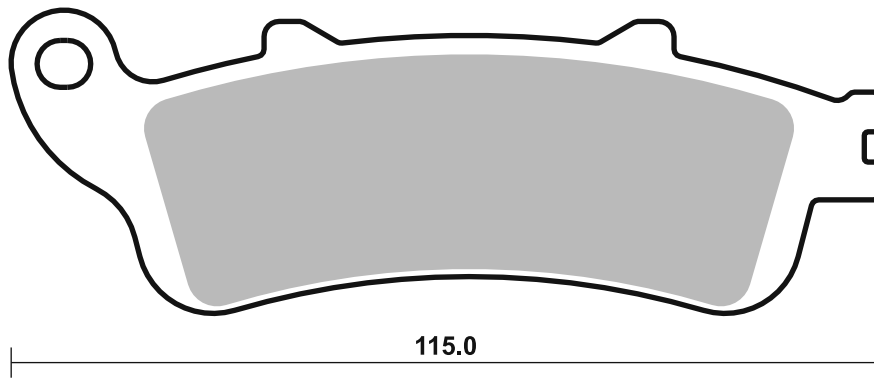



STREET HF • HS • LS  
 AMERICAN H.HF • H.CT • H.HS • H.LS  
 SCOOTER HF • CT • MS

RACING  
 OFF ROAD  
 ATV

RST • DC • DCC • DS-1 • DS-2 • RQ  
 SI • RSI • CS  
 ATS • SI • RSI • PSI

Available compounds

HF • SI

SBS 749

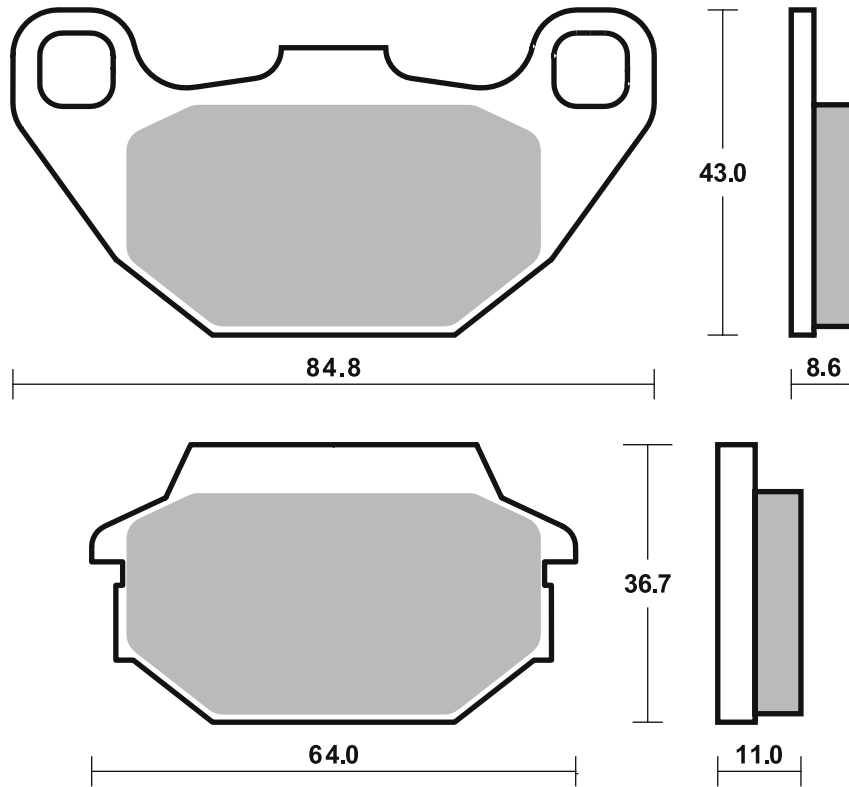

Available compounds

CS • SI • RSI

SBS 752

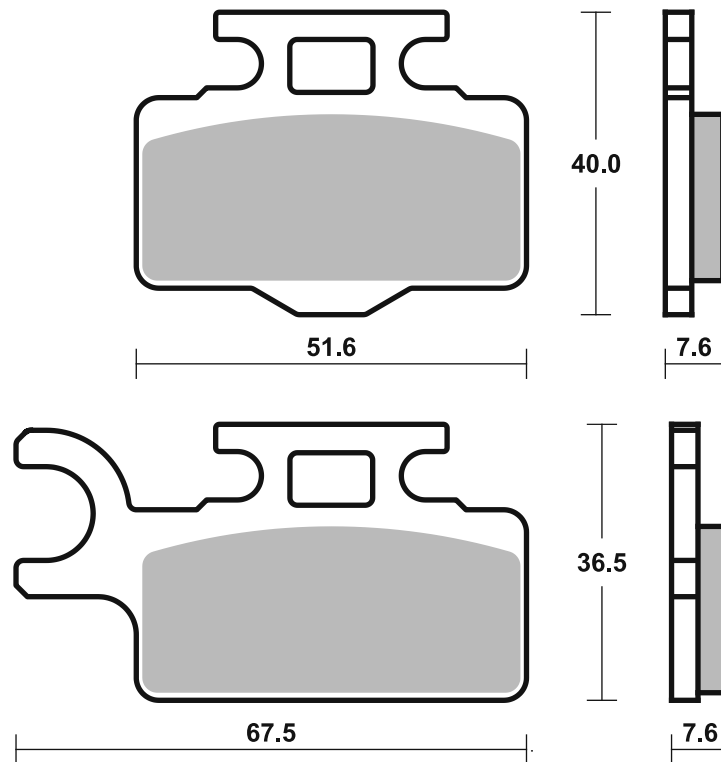

# Applications

## SBS 754

### Recommended compound



<b>BOMBARDIER</b>				
DS	250	06 - 06	SI	SI
	330 Outlander	03 - 06	SI	SI
	400 Outlander	03 - 06	SI	SI
	400 Outlander Max	03 - 06	SI	SI
	500 Quest	02 - 06	SI	SI
	500 Traxter 4x4	01 - 06	SI	
	500 Traxter Max	03 - 05	SI	
	650 Quest	02 - 06	SI	SI
	650 Quest Max	03 - 06	SI	
	650 Traxter Max	03 - 05	SI	
DS	650	01 - 06	SI	SI
	800 Outlander	06 - 06	SI	SI
	800 Outlander XT	06 - 06	SI	SI

<b>CAN-AM</b>				
	400 Outlander EFI	09 - 14	SI	SI
	400 Outlander			
	MAX STD	07 - 13	SI	SI
	400 Outlander			
	MAX XT	07 - 13	SI	SI
	400 Outlander STD	07 - 14	SI	SI
	400 Outlander XT	07 - 14	SI	SI
	500 Outlander			
	MAX STD	07 - 12	SI	SI
	500 Outlander			
	MAX XT	07 - 12	SI	SI
	500 Outlander STD	07 - 12	SI	SI
	500 Outlander XT	07 - 12	SI	SI
	500 Renegade	08 - 11	SI	SI
	650 Outlander			
	MAX STD	07 - 12	SI	SI



<b>CAN-AM</b>				
	650 Outlander			
	MAX XT	07 - 12	SI	SI
	650 Outlander STD	07 - 12	SI	SI
	650 Outlander XT	07 - 12	SI	SI
	800 Commander			
	MAX R EFI	18 - 20	PSI	
	800 Commander			
	R EFI	18 - 18	PSI	
	800 Outlander			
	MAX LTD	07 - 11	SI	SI
	800 Outlander			
	MAX STD	07 - 11	SI	SI
	800 Outlander			
	MAX XT	07 - 11	SI	SI
	800 Outlander STD	07 - 11	SI	SI
	800 Outlander XT	07 - 11	SI	SI
	800 Renegade	08 - 11	SI	SI
	800 Renegade EFI	07 - 11	SI	SI
	800 Renegade X	08 - 11	SI	SI
	1000 Commander	16 - 17	PSI	
	1000 Commander			
	MAX	14 - 17	PSI	
	1000 Commander			
	MAX R EFI	18 - 19	PSI	
	1000 Commander			
	R EFI	18 - 20	PSI	
	1000 Maverick	14 - 18	PSI	
	1000 Maverick MAX	14 - 18	PSI	

<b>CANNONDALE</b>				
	440 Blaze	03 - 03	SI	SI



<b>CANNONDALE</b>				
	440 Cannibal	03 - 03	SI	SI
	440 Glamis	03 - 03	SI	SI
	440 Moto	03 - 03	SI	SI
	440 Speed	03 - 03	SI	SI

<b>JOHN DEERE</b>				
	500 Buck	05 - 05	SI	
	500 Buck EX, EXT	05 - 05	SI	
	500 Trail Buck	05 - 05	SI	
	650 Trail Buck	05 - 05	SI	
	650 Trail Buck EX, EXT	05 - 05	SI	

<b>YAMAHA</b>				
YFM	400 FAM Kodiak	00 - 02		SI
YFM	400 FWN Big Bear			
	4WD	00 - 11		SI
YFM	400 FWNH Big Bear-Buckmaster			
	4WD	00 - 11		SI
YFM	400 N Big Bear 2WD	00 - 11		SI
YFM	450 FA Kodiak	03 - 07		SI
YFM	450 Wolverine	06 - 10		SI

## SBS 755

### Recommended compound



<b>POLARIS</b>				
	250 Trail Blazer	99 - 07		ATS
	250 Xplorer 4x4	00 - 02		ATS
	325 Magnum 2x4, 4x4	00 - 02		ATS
	325 Trail Boss	00 - 02		ATS
	325 Xpedition	00 - 01		ATS
	330 Trail Boss	03 - 14		ATS
	335 Sportsman 4x4	99 - 02		ATS
	400 Scrambler 2x4, 4x4	00 - 03		ATS
	400 Scrambler 4x4	99 - 03		ATS
	400 Sport	99 - 00		ATS
	400 Sportsman	01 - 13		ATS
	400 Trail Blazer	03 - 04		ATS
	400 Xplorer L 4x4	00 - 02		ATS
	425 Xpedition 4x4	00 - 03		ATS
	455 Diesel EBS 4x4	99 - 01		ATS
	500 Magnum 4x4	00 - 01		ATS
	500 Scrambler 2x4	01 - 02		ATS
	500 Sportsman EBS 4x4	98 - 02		ATS

STREET  
AMERICAN  
SCOOTER

HF • HS • LS  
H.HF • H.CT • H.HS • H.LS  
HF • CT • MS

RACING  
OFF ROAD  
ATV

RST • DC • DCC • DS-1 • DS-2 • RQ  
SI • RSI • CS  
ATS • SI • RSI • PSI

Drawings 1:1

Available compounds

HF • SI • RSI • PSI

SBS 754

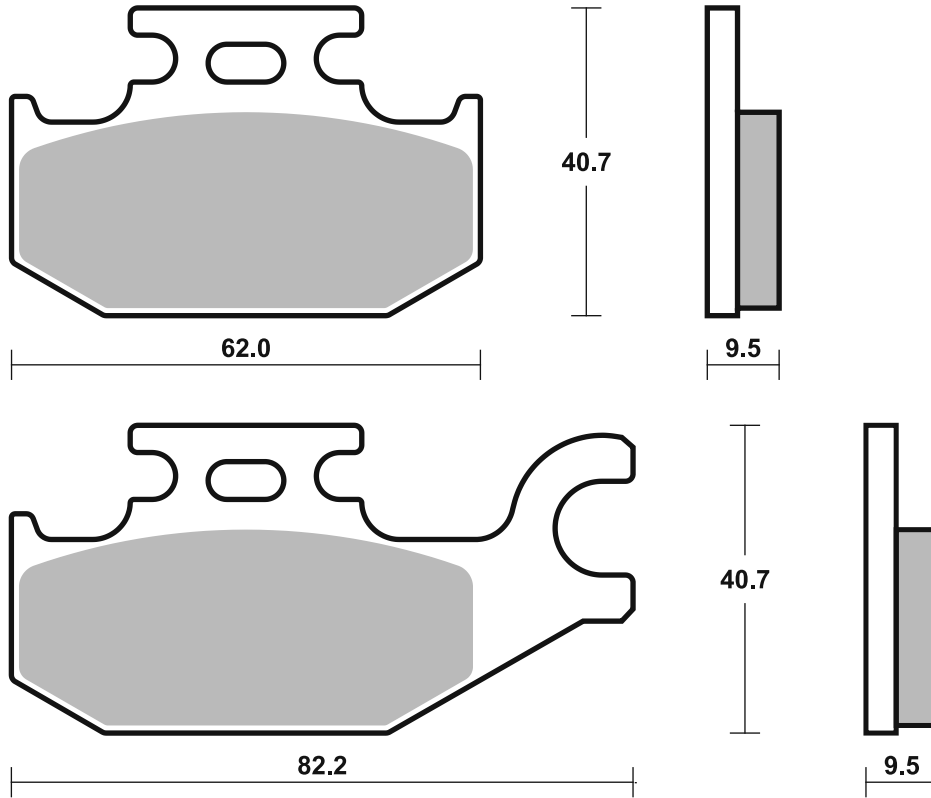

Available compounds

SI • RSI • ATS

SBS 755

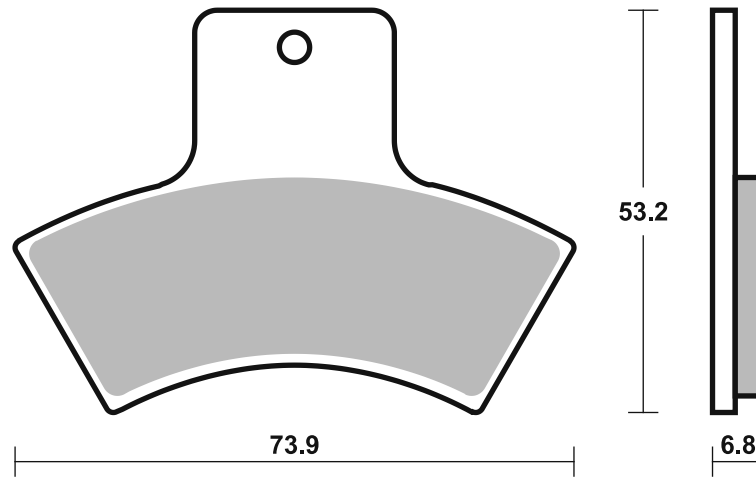

## Applications

### SBS 756

#### Recommended compound



<b>POLARIS</b>			
400 Big Boss L 6x6			
Middle Axle			
Brake	96 - 96	ATS	
425 Magnum 6x6			
Middle Axle			
Brake	96 - 96	ATS	

### SBS 757

#### Recommended compound



<b>POLARIS</b>			
500 Sportsman 6x6	00 - 11	ATS	

### SBS 758

#### Recommended compound



<b>ARCTIC CAT</b>			
250 2x4/4x4	99 - 04	ATS	ATS
300 2x4/4x4	98 - 04	ATS	ATS
375 2x4/4x4	02 - 02	ATS	ATS
400 2x4/4x4	98 - 04	ATS	ATS
400 2x4/4x4 (FIS)	02 - 04	ATS	ATS
400 2x4/4x4 (FIS) (Man. Hand Brake)			
	05 - 08	ATS	
400 TBX 4x4	04 - 04	ATS	ATS
440 Bear Cat	96 - 97	ATS	ATS
454 Arctic Cat 4x4	98 - 98	ATS	ATS
454 Bear Cat			
2x4/4x4	96 - 98	ATS	ATS
500 2x4/4x4	98 - 04	ATS	ATS
500 2x4/4x4 (FIS)	02 - 04	ATS	ATS
500 TBX 4x4	02 - 04	ATS	ATS
500 TRV 4x4	03 - 04	ATS	ATS



<b>LAVERDA</b>			
HP 125 Quasar	04 - 04	ATS	
HP 180 Quasar	04 - 04	ATS	
400 Quasar 4x4	04 - 04	ATS	ATS
500 Quasar 4x4	04 - 04	ATS	ATS
500 Quasar 4x4 C	04 - 04	ATS	ATS

Brake Pad 1:1 Drawings, Compounds, Fitments

STREET HF • HS • LS  
AMERICAN H.HF • H.CT • H.HS • H.LS  
SCOOTER HF • CT • MS

RACING  
OFF ROAD  
ATV

RST • DC • DCC • DS-1 • DS-2 • RQ  
SI • RSI • CS  
ATS • SI • RSI • PSI

Drawings 1:1

Available compounds

SI • RSI • ATS

SBS 756

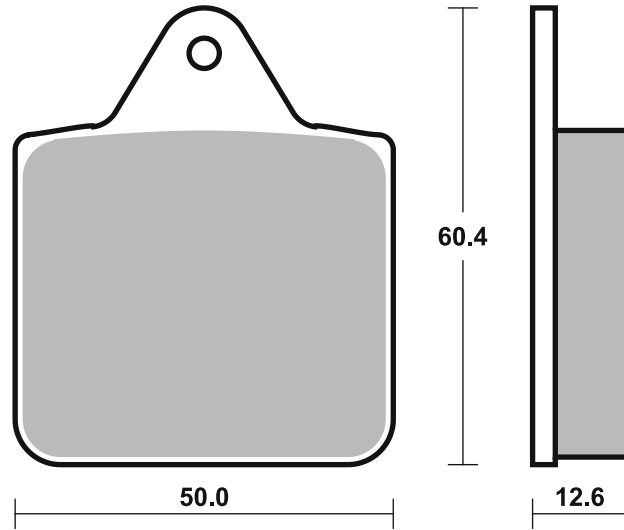

Available compounds

SI • RSI • ATS

SBS 757

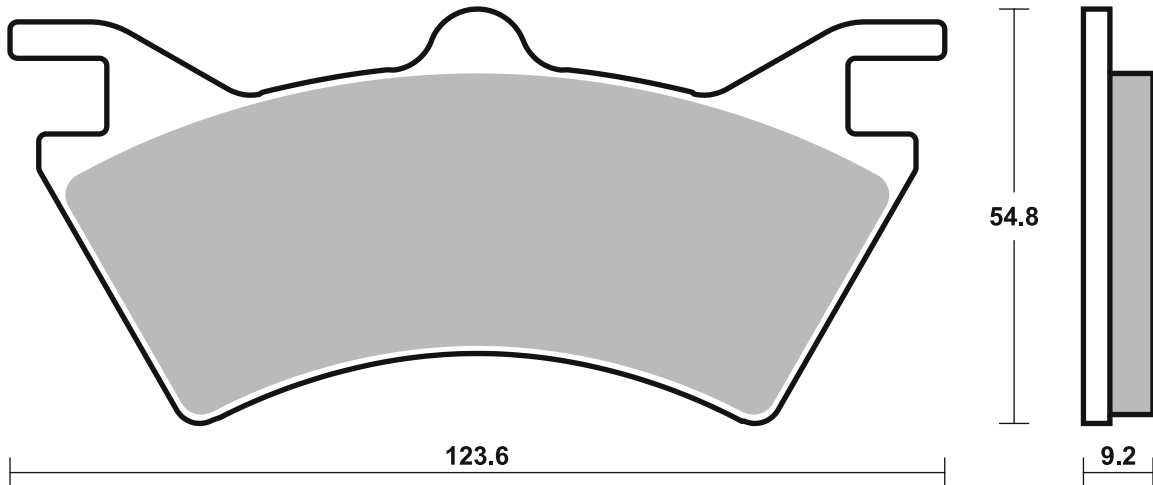

Available compounds

SI • RSI • ATS

SBS 758

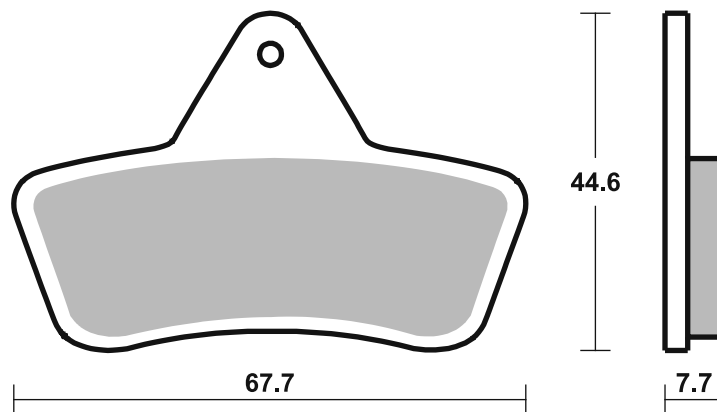

**SBS 759**

**Recommended compound**



**BREMBO RACING CALIPERS**

Racing rear X206001, P2 24

**SBS 762**

**Recommended compound**



**APRILIA**

RSV	1000	02 - 03	HS
RSV	1000 Factory Pista	04 - 04	HS
RSV	1000 Nera	04 - 04	HS
RSV	1000 R	01 - 07	HS
RSV	1000 R Factory	04 - 08	HS
RSV	1000 Tuono R	03 - 03	HS
RSV	1000 Tuono R Factory, ABS	06 - 12	HS

**BENELLI**

BX	449 Supermotard	08 - 10	RST
	500 C	19 - 19	HS
	500 Leoncino		
	Cinquecento	18 - 19	HS
	500 Tornado Naked	23 - 23	HS
	502 C	23 - 24	HS
TRK	502	18 - 24	HS
BN	600	14 - 17	HS
BN	600 GT	14 - 15	HS
T	600 Tornado Naked	20 - 20	HS
TRK	702	24 - 24	HS
	752 S	18 - 18	HS
	756 Cue	07 - 09	HS
	800 Leoncino	22 - 23	HS
	800 Leoncino Trail	22 - 23	HS
TNT	899 Century Racer	11 - 11	HS
	900 Tornado TRE	03 - 06	HS
	900 Tornado TRE RS	04 - 06	HS
TNT	1130 Cafe Racer	05 - 13	HS
TNT	1130 Century Racer	11 - 12	HS
TNT	1130 Officine	07 - 07	HS
TNT	1130 Sport	05 - 08	HS
TNT	1130 Titanium	05 - 08	HS

**BIMOTA**

DB5	1000	05 - 11	HS
DB5	1000 S	07 - 11	HS
DB6	1000 Delirio	07 - 09	HS
SB8K	1000 Santamonica	07 - 09	HS
DB10	1078 Bimotard	12 - 12	HS
DB5	1078 RE	12 - 12	HS
DB7	1098	08 - 08	HS
3D	1100 Tesi	07 - 11	HS
DB6R	1100 Delirio	08 - 09	HS

**BIMOTA**

DB12	1200	12 - 12	HS
DB9	1200 Brivido	12 - 18	HS

**BMW**

G	450 SMR	09 - 10	RST
---	---------	---------	-----

**BREMBO RACING CALIPERS**

Goldline 4 pad 20.7850.11/21,  
road  
Motard Axial XA32950, P4 34

**CAGIVA**

	1000 X3 Raptor	04 - 04	HS
	1000 X-Raptor	03 - 04	HS

**DERBI**

	659 Mulhacen	06 - 07	HS
	659 Mulhacen Cafe	08 - 08	HS

**DUCATI**

	748 R	01 - 02	HS
	749 , S	03 - 07	HS
	749 R	04 - 07	HS
	996 R	01 - 01	HS
	996 RS		
	(slipper clutch)	00 - 01	HS
	998 Monster S4Rs	06 - 06	HS
	998 R	02 - 04	HS
	998 RS		
	(slipper clutch)	02 - 03	HS
	999	03 - 07	HS
	999 Monster S4R	07 - 08	HS
	999 Monster S4RS	07 - 08	HS
	999 R	03 - 07	HS
	999 RS		
	(slipper clutch)	04 - 05	HS
	999 S	03 - 07	HS
	1000 Hypermotard	06 - 06	HS

**GILERA**

	600 Supersport	02 - 02	HS
--	----------------	---------	----

**HUSQVARNA**

SMR	449	11 - 13	RST
-----	-----	---------	-----



**HUSQVARNA**

SM	450 R	05 - 13	RST
SM	450 RR	06 - 10	RST
SM	510 Centennial	06 - 06	RST
SM	510 R	05 - 10	RST
SMR	511	11 - 13	RST
SM	610 ie	07 - 10	RST
SM	630	10 - 10	HS
STR	650 CRC	07 - 07	HF
SM	701 Supermoto	15 - 20	HS

**HYOSUNG**

RX	450 SM	08 - 11	HS
----	--------	---------	----

**KTM**

	690 Duke	08 - 11	HS
	690 Duke R	10 - 11	HS
	690 SM	07 - 11	HS
	690 SMC	08 - 10	HS
	690 SMC R	14 - 20	HS
	690 Supermoto R	08 - 09	HS
	950 SM	05 - 07	HS
	950 SM R	07 - 09	HS
	990 Super Duke	04 - 13	HS
	990 Super Duke R	09 - 13	HS
	990 Supermoto	07 - 11	HS
	990 Supermoto T	09 - 13	HS

**LAVERDA**

SFC	1000	04 - 04	HS
-----	------	---------	----

**MONDIAL**

	1000 EVO	04 - 04	HS
	1000 Piega	03 - 04	HS
	1000 RZ Nuda	04 - 04	HS
	1000 Starfighter	04 - 04	HS

**MOTO-GUZZI**

	1200 MGS-01 Corsa	05 - 13	HS
--	-------------------	---------	----

**MOTO-MORINI**

	1200 Granferro	10 - 10	HS
--	----------------	---------	----

**MV AGUSTA**

	910 Brutale R	06 - 08	HS
--	---------------	---------	----

Brake Pad 1:1 Drawings,  
Compounds, Fitments



STREET HF • HS • LS  
AMERICAN H.HF • H.CT • H.HS • H.LS  
SCOOTER HF • CT • MS

RACING  
OFF ROAD  
ATV

RST • DC • DCC • DS-1 • DS-2 • RQ  
SI • RSI • CS  
ATS • SI • RSI • PSI

Drawings 1:1

Available compounds

RQ

SBS 759

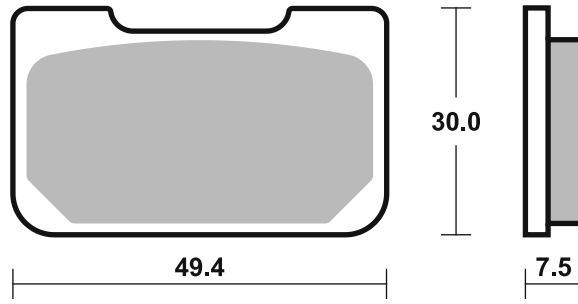

Available compounds

HF • HS • DC • RST • DS-1

SBS 762

1 set = 4 pcs.

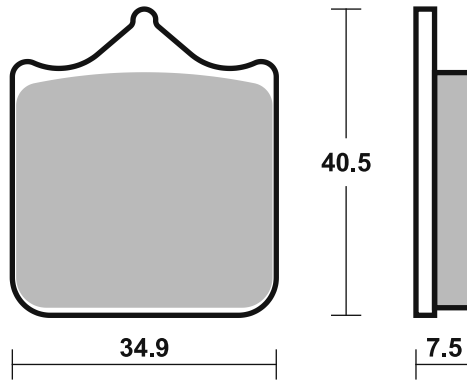

## Applications

### SBS 762

### Recommended compound



<b>MV AGUSTA</b>			
F4	1000 R	06 - 07	<b>HS</b>
<b>NORTON</b>			
	961 Commando		
	Cafe Racer	11 - 14	<b>HS</b>
	961 Commando SE	12 - 14	<b>HS</b>
	961 Commando SF	13 - 15	<b>HS</b>
<b>QJ MOTOR</b>			
SRK	600	24 - 24	<b>HS</b>
<b>SHERCO</b>			
SM	450 4.5i Supermotard	06 - 06	<b>RST</b>
<b>SWM</b>			
	440 Gran Milano	18 - 18	<b>HS</b>
SM	450 R	15 - 17	<b>HS</b>
	500 Ace of Spades	18 - 21	<b>HS</b>



<b>SWM</b>			
	500 Gran Milano		
	Outlaw	18 - 21	<b>HS</b>
SM	500 R	18 - 20	<b>HS</b>
	650 Superdual	15 - 18	<b>HS</b>
<b>TM</b>			
SMX	450 F	04 - 04	<b>RST</b>
SMX	660 F	04 - 04	<b>RST</b>
<b>TRIUMPH</b>			
	900 Scrambler	23 - 23	<b>HS</b>
	900 Speed Twin	23 - 23	<b>HS</b>
	900 Street Scrambler	19 - 22	<b>HS</b>
	900 Street Twin	19 - 22	<b>HS</b>
	1050 Speed 94	15 - 16	<b>HS</b>
	1050 Speed Triple	08 - 15	<b>HS</b>
	1200 Speed Twin	19 - 20	<b>HS</b>

### SBS 763

### Recommended compound



<b>MV AGUSTA</b>			
F3	675	11 - 12	<b>LS</b>
	750 Brutale,		
	Brutale S	01 - 05	<b>LS</b>
F4	750	99 - 02	<b>LS</b>
F4	750 SPR	01 - 03	<b>LS</b>
F3	800	14 - 20	<b>LS</b>
	910 Brutale	06 - 08	<b>LS</b>
	910 Brutale R	06 - 08	<b>LS</b>
	910 Brutale S	06 - 08	<b>LS</b>
	920 Brutale	12 - 14	<b>LS</b>
	989 Brutale R	09 - 09	<b>LS</b>
	990 Brutale R	10 - 11	<b>LS</b>
F4	1000 LH44	18 - 20	<b>LS</b>
F4	1000 Mamba	04 - 06	<b>LS</b>
F4	1000 R	06 - 07	<b>LS</b>
F4	1000 R	12 - 19	<b>LS</b>
F4	1000 RC	15 - 20	<b>LS</b>
F4	1000 RR	12 - 20	<b>LS</b>



<b>MV AGUSTA</b>			
F4	1000 S	04 - 06	<b>LS</b>
F4	1000 Tamburini	04 - 06	<b>LS</b>
	1078 Brutale RR	09 - 09	<b>LS</b>
F4	1078 312 RR	08 - 11	<b>LS</b>
F4	1078 CC	08 - 11	<b>LS</b>
	1090 Brutale Corse	14 - 16	<b>LS</b>
	1090 Brutale R	12 - 15	<b>LS</b>
	1090 Brutale RR	10 - 17	<b>LS</b>

### SBS 765

### Recommended compound



<b>SUZUKI</b>			
GSX-R	600	04 - 05	<b>LS</b>
GSF	650 Bandit / S Bandit	05 - 05	<b>LS</b>
GSX-R	750	04 - 05	<b>LS</b>
GSX-R	1000	01 - 03	<b>LS</b>
GSX	1400	02 - 07	<b>LS</b>

STREET HF • HS • LS  
 AMERICAN H.HF • H.CT • H.HS • H.LS  
 SCOOTER HF • CT • MS

RACING  
 OFF ROAD  
 ATV

RST • DC • DCC • DS-1 • DS-2 • RQ  
 SI • RSI • CS  
 ATS • SI • RSI • PSI

Drawings 1:1

Available compounds

HF • HS • DC • RST • DS-1

SBS 762

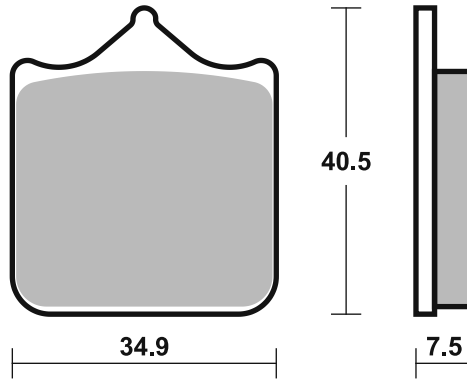

Available compounds

HF • LS • RQ

SBS 763

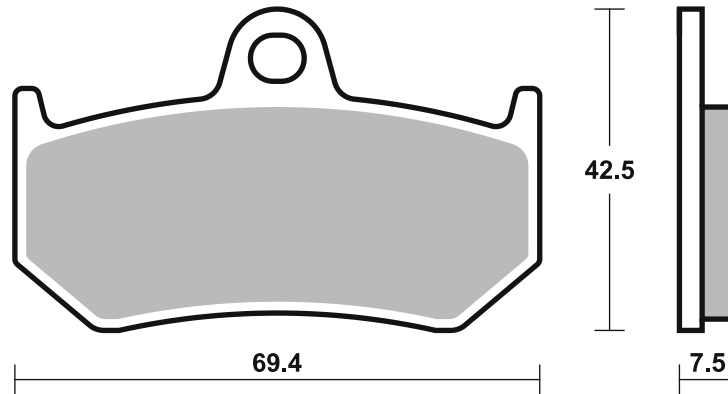

Available compounds

HF • LS • RQ

SBS 765

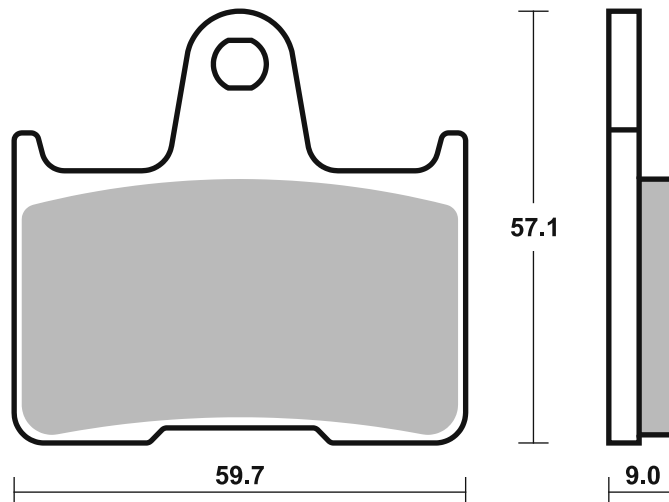

**Applications**

**SBS 766**

**Recommended compound**



<b>NISSIN</b>			
3 Piston Racing Rear Caliper			

**SBS 767**

**Recommended compound**



<b>BOMBARDIER</b>			
DS	250	06 - 06	SI
	330 Outlander	03 - 06	SI
	400 Outlander	03 - 06	SI
	400 Outlander Max	03 - 06	SI
	500 Quest	02 - 06	SI
	500 Traxter 4x4	01 - 06	SI SI
	500 Traxter Max	03 - 05	SI SI
	650 Quest	02 - 06	SI
	650 Quest Max	03 - 06	SI SI
	650 Traxter Max	03 - 05	SI SI
DS	650	01 - 06	SI
	800 Outlander	06 - 06	SI
	800 Outlander XT	06 - 06	SI
<b>CAN-AM</b>			
	400 Outlander EFI	09 - 14	SI
	400 Outlander MAX STD	07 - 13	SI
	400 Outlander MAX XT	07 - 13	SI
	400 Outlander STD	07 - 14	SI
	400 Outlander XT	07 - 14	SI
	500 Outlander MAX STD	07 - 12	SI
	500 Outlander MAX XT	07 - 12	SI
	500 Outlander STD	07 - 12	SI
	500 Outlander XT	07 - 12	SI
	500 Renegade	08 - 11	SI
	600 Ryker	19 - 23	PSI



<b>CAN-AM</b>			
	650 Outlander MAX STD	07 - 12	SI
	650 Outlander MAX XT	07 - 12	SI
	650 Outlander STD	07 - 12	SI
	650 Outlander XT	07 - 12	SI
	800 Outlander MAX LTD	07 - 11	SI
	800 Outlander MAX STD	07 - 11	SI
	800 Outlander MAX XT	07 - 11	SI
	800 Outlander STD	07 - 11	SI
	800 Outlander XT	07 - 11	SI
	800 Renegade	08 - 11	SI
	800 Renegade EFI	07 - 11	SI
	800 Renegade X	08 - 11	SI
	900 Ryker	19 - 23	PSI
	900 Ryker Rally	19 - 23	PSI
	900 Ryker S	19 - 23	PSI
<b>CANNONDALE</b>			
	440 Blaze	03 - 03	SI
	440 Cannibal	03 - 03	SI
	440 Glamis	03 - 03	SI
	440 Moto	03 - 03	SI
	440 Speed	03 - 03	SI
<b>JOHN DEERE</b>			
	500 Buck	05 - 05	SI SI
	500 Buck EX, EXT	05 - 05	SI SI



<b>JOHN DEERE</b>			
	500 Trail Buck	05 - 05	SI SI
	650 Trail Buck	05 - 05	SI SI
	650 Trail Buck EX, EXT	05 - 05	SI SI

Brake Pad 1:1 Drawings, Compounds, Fitments

STREET HF • HS • LS  
 AMERICAN H.HF • H.CT • H.HS • H.LS  
 SCOOTER HF • CT • MS

RACING  
 OFF ROAD  
 ATV

RST • DC • DCC • DS-1 • DS-2 • RQ  
 SI • RSI • CS  
 ATS • SI • RSI • PSI

Drawings 1:1

Available compounds

LS

SBS 766

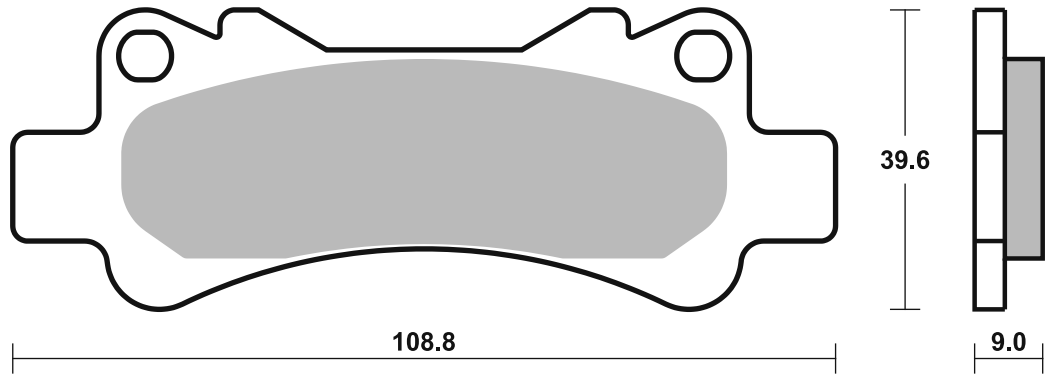

Available compounds

SI • RSI • PSI

SBS 767

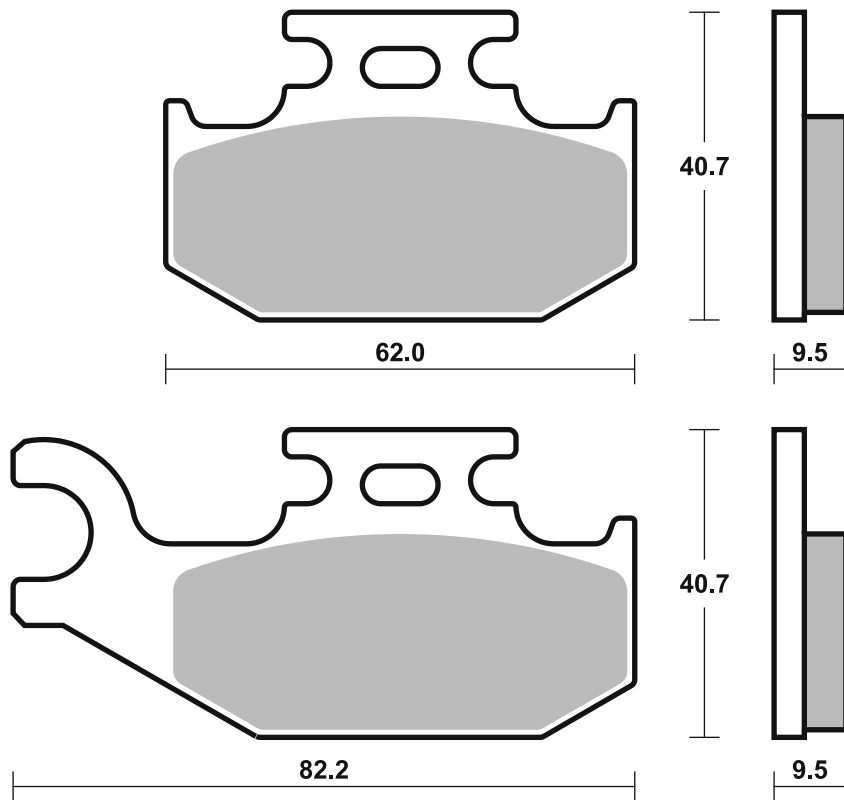

# Applications

## SBS 769 Recommended compound



<b>HYOSUNG</b>			
GV	650 Aquila	04 - 05	HF
<b>YAMAHA</b>			
TDM	900	02 - 14	LS
SCR	950 Scrambler	17 - 19	LS
XV	950 Bolt	14 - 18	LS
XV	950 Bolt C-Spec	15 - 18	LS
XV	950 Bolt Racer	17 - 18	LS
XV	950 Bolt R-Spec	14 - 21	LS
XV	950 R	19 - 20	LS
XVS	950 A Midnight Star	09 - 13	LS
XT	1200 Z Super Tenere	14 - 19	LS
XT	1200 ZE Super Tenere	14 - 19	LS
XT	1200 ZE Super Tenere Raid Ed.	18 - 19	LS
XTZ	1200 Super Tenere	10 - 13	LS
FJR	1300	01 - 03	LS
FJR	1300 A	13 - 20	LS



<b>YAMAHA</b>			
FJR	1300 ABS	03 - 12	LS
FJR	1300 AE	16 - 19	LS
FJR	1300 AS	13 - 19	LS
XVS	1300 A Midnight Star	07 - 11	LS
XVS	1300 Custom	14 - 16	LS
XVS	1300 Stryker	11 - 14	LS
VMX	1700 V-Max	09 - 18	LS
XV	1700 PC Road Star Warrior	03 - 07	LS
XV	1900 A	11 - 11	LS
XV	1900 A Midnight Star	06 - 10	LS

## SBS 770 Recommended compound



<b>YAMAHA</b>			
FZS	1000 Fazer	01 - 05	LS
XJR	1300	02 - 18	LS
XJR	1300 Racer	15 - 19	LS

## SBS 771 Recommended compound



<b>BERINGER</b>			
6 Piston Caliper			

STREET HF • HS • LS  
 AMERICAN H.HF • H.CT • H.HS • H.LS  
 SCOOTER HF • CT • MS

RACING  
 OFF ROAD  
 ATV

RST • DC • DCC • DS-1 • DS-2 • RQ  
 SI • RSI • CS  
 ATS • SI • RSI • PSI

Drawings 1:1

Available compounds HF • LS

SBS 769

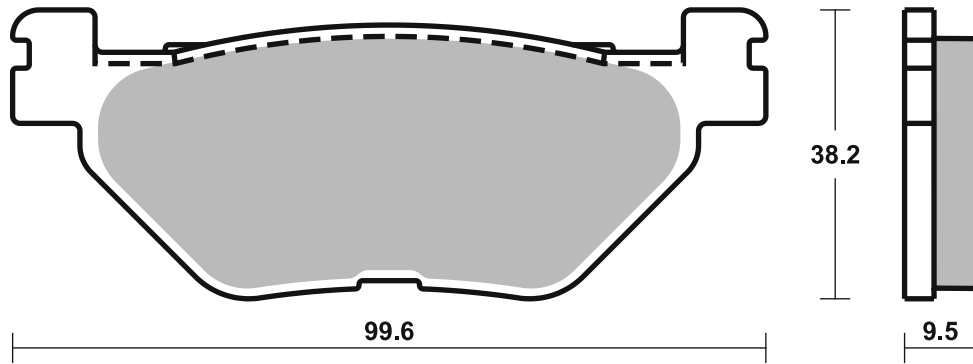

Available compounds

HF • LS

SBS 770

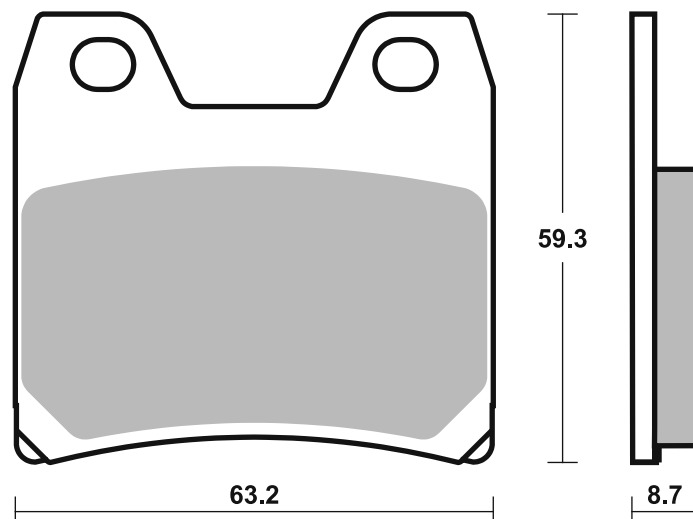

Available compounds

HF • HS • RQ

SBS 771

1 set = 6 pcs.

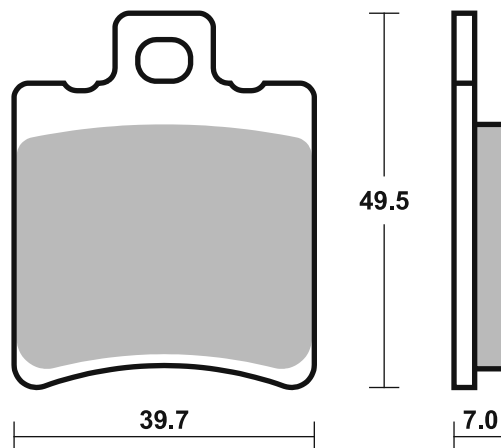

Brake Pad 1:1 Drawings,  
 Compounds, Fitments

Applications

SBS 772

Recommended compound



DERBI			
GP1	250	05 - 09	HF

SBS 773

Recommended compound



SCORPA			
250 T-Ride		08 - 11	HF
SHERCO			
SE	125 1.25F	10 - 12	HF
YAMAHA			
XT	125 R	05 - 13	HF
XT	125 X Supermotard	05 - 13	HF

Brake Pad 1:1 Drawings,  
Compounds, Fitments



STREET HF • HS • LS  
AMERICAN H.HF • H.CT • H.HS • H.LS  
SCOOTER HF • CT • MS

RACING  
OFF ROAD  
ATV

RST • DC • DCC • DS-1 • DS-2 • RQ  
SI • RSI • CS  
ATS • SI • RSI • PSI

Drawings 1:1

Available compounds

HF

SBS 772

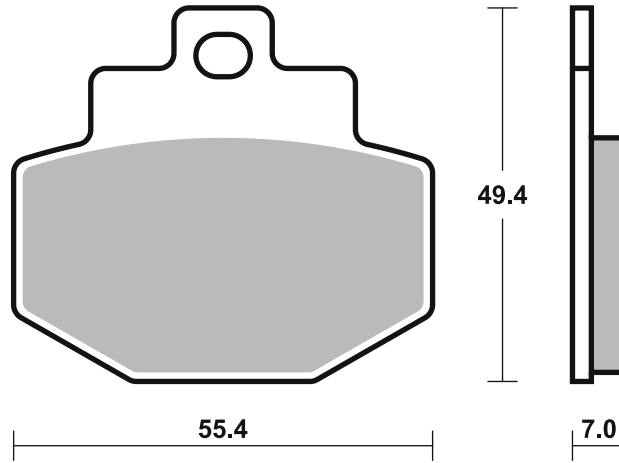

Available compounds

HF

SBS 773

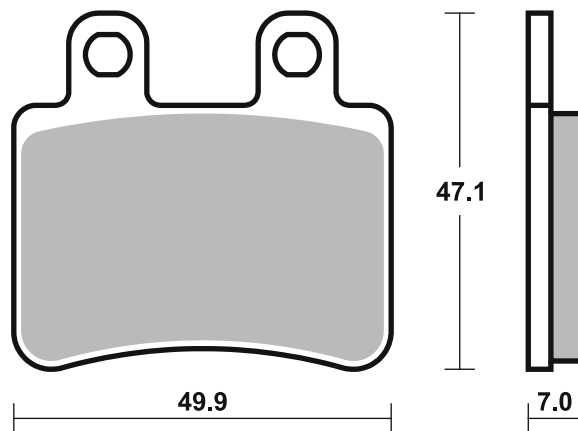

## Applications

### SBS 774

### Recommended compound



<b>AJP</b>			
PR3	125 Enduro	08 - 12	HF
PR3	125 Supermotard	08 - 12	HF
MX	200	09 - 11	HF
PR3	200 Enduro	08 - 12	HF
PR3	200 Supermotard	08 - 12	HF
<b>BETA</b>			
	125 M4	06 - 06	HF
	125 Urban	10 - 15	HF
ALP	125 4-stroke	06 - 09	HF
RR	125 Enduro 4T	10 - 15	HF
RR	125 Supermotard	08 - 09	HF
	200 Urban	10 - 10	HF
ALP	200 4-stroke	06 - 20	HF
ALP	350 4.0	04 - 18	HF
<b>DERBI</b>			
	125 Mulhacen	07 - 07	HF
	125 Senda R 4T	04 - 12	HF
	125 Senda X-Treme		
	SM 4T	04 - 05	HF
<b>FANTIC</b>			
	125 Regolarna Casa	08 - 08	HF
	125 Supersei		
	Motard	08 - 08	HF
<b>GASGAS</b>			
	125 Pampera	04 - 13	HF
	250 Pampera	02 - 13	HF
	280 Pampera	04 - 08	HF
<b>HM</b>			
CRE	50	06 - 13	HF



<b>KEEWAY</b>			
	125 Enduro	07 - 08	HF
	125 X-Ray	07 - 08	HF
<b>SHERCO</b>			
SE	125 1.25F	10 - 12	HF
<b>YAMAHA</b>			
XT	125 R	05 - 13	HF
XT	125 X Supermotard	05 - 13	HF

### SBS 775

### Recommended compound



<b>ARCTIC CAT</b>			
	250 DVX	06 - 09	SI
	300 DVX	09 - 16	SI
<b>GILERA</b>			
	250 Oregon Quad	07 - 11	SI
<b>KYMCO</b>			
	250 MXU	06 - 14	SI
	250 Urban Quad	06 - 06	SI
KXR	250	04 - 14	SI
	300 Maxxer	06 - 13	SI
	300 Maxxer		
	Supermoto	15 - 15	SI

STREET HF • HS • LS  
 AMERICAN H.HF • H.CT • H.HS • H.LS  
 SCOOTER HF • CT • MS

RACING  
 OFF ROAD  
 ATV

RST • DC • DCC • DS-1 • DS-2 • RQ  
 SI • RSI • CS  
 ATS • SI • RSI • PSI

Drawings 1:1

Available compounds

HF

SBS 774

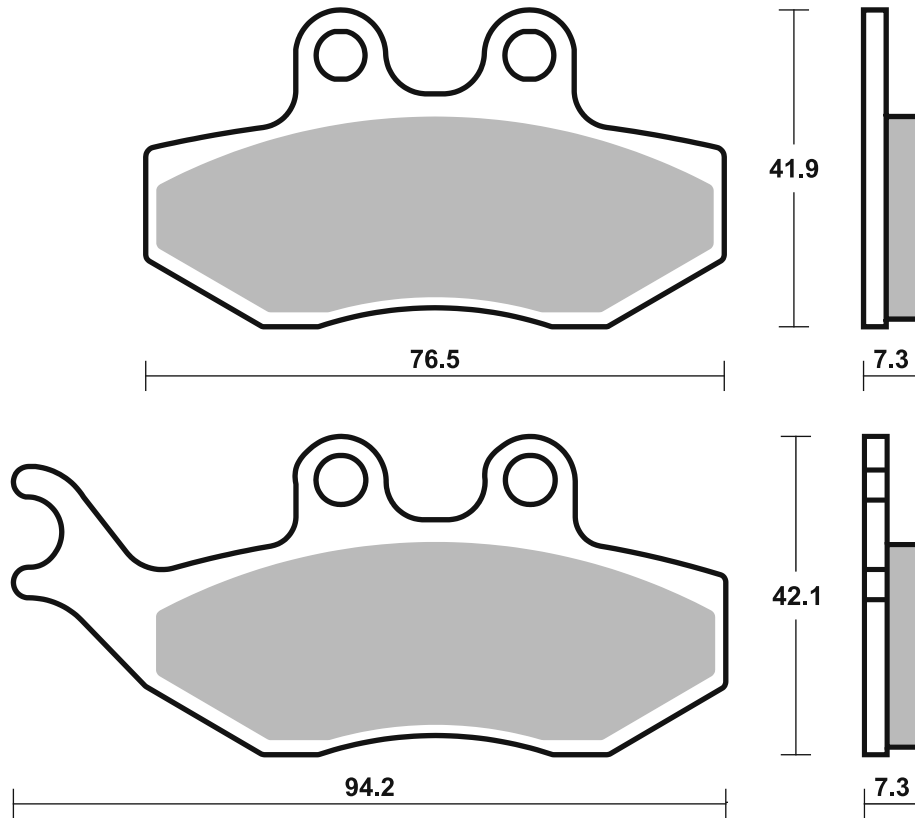

Available compounds

HF • SI • RSI

SBS 775

1 set = 4 pcs.

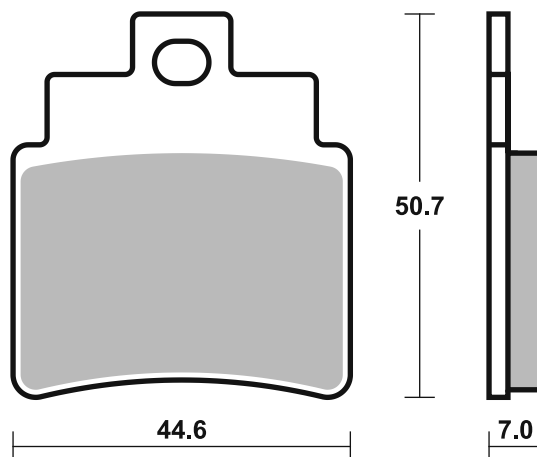

## Applications

### SBS 777

### Recommended compound



<b>BRACING</b>			
Rear cross (1 piston)			
<b>FANTIC</b>			
125 Caballero			
Enduro 2T	12 - 10		<b>HF</b>
125 Caballero			
Motard 2T	10 - 10		<b>HF</b>
125 Caballero			
Motard 4T	10 - 10		<b>HF</b>
125 Caballero			
Regularita 4T	10 - 10		<b>HF</b>
XEF 125 Competition	22 - 22		<b>HF</b>
XMF 125 Competition	22 - 22		<b>HF</b>
200 Caballero			
Motard 4T	10 - 10		<b>HF</b>
200 Caballero			
Regularita 4T	10 - 10		<b>HF</b>
250 Enduro 4T	16 - 17		<b>HF</b>
<b>HM</b>			
CR	125 Supermotard	04 - 06	<b>RSI</b>
CRE	125 Enduro	02 - 06	<b>SI</b>
CRM	125 X Supermotard	07 - 07	<b>RSI</b>
CRE	250 Enduro	02 - 03	<b>SI</b>
CRE	250 F Enduro	04 - 13	<b>SI</b>
CRE	250 Supermotard	04 - 07	<b>RSI</b>
CRE	250 X Enduro	04 - 13	<b>SI</b>
CRF	250 Supermotard	04 - 06	<b>RSI</b>
CRM	250 X Supermotard	07 - 13	<b>RSI</b>
CRE	450 F Enduro	02 - 13	<b>SI</b>
CRE	450 X Enduro	04 - 13	<b>SI</b>



<b>HM</b>			
CRF	450 Supermotard	02 - 06	<b>RSI</b>
CRM	450 X Supermotard	07 - 13	<b>RSI</b>
CRM	500 X Supermotard	07 - 13	<b>RSI</b>
<b>HONDA</b>			
CR	125 R	02 - 07	<b>RSI</b>
CRE	125	02 - 07	<b>SI</b>
CRE	125 RR	11 - 11	<b>SI</b>
CRF	150 R	07 - 24	<b>RSI</b>
CR	250 R	02 - 07	<b>RSI</b>
CRE	250	02 - 07	<b>SI</b>
CRE	250 F	04 - 04	<b>SI</b>
CRF	250 F	19 - 24	<b>SI</b>
CRF	250 R	04 - 24	<b>RSI</b>
CRF	250 RX	19 - 24	<b>SI</b>
CRF	250 X	04 - 19	<b>SI</b>
CRE	450 F	02 - 06	<b>SI</b>
CRF	450 L	19 - 21	<b>RSI</b>
CRF	450 R	02 - 24	<b>RSI</b>
CRF	450 R-S	22 - 24	<b>RSI</b>
CRF	450 RWE	19 - 24	<b>RSI</b>
CRF	450 RX	17 - 24	<b>SI</b>
CRF	450 X	05 - 24	<b>SI</b>
<b>KOVE</b>			
MX	250	24 - 24	<b>RSI</b>
MX	250 Enduro	24 - 24	<b>SI</b>
MX	250 Off Road	23 - 23	<b>RSI</b>
MX	250 Supermoto	23 - 23	<b>HF</b>
	450 Rally	23 - 23	<b>SI</b>
MX	450	24 - 24	<b>RSI</b>



<b>MEGELLI</b>			
	125 M, R, S	08 - 10	<b>HF</b>
<b>SUZUKI</b>			
RME	50	10 - 10	<b>HF</b>
<b>TM</b>			
MX	85	13 - 24	<b>RSI RSI</b>
SM	85	18 - 19	<b>RSI RSI</b>

### SBS 778

### Recommended compound



<b>BMW</b>			
R	850 R	03 - 07	<b>HS</b>
R	1100 S With Integral		
	ABS	01 - 05	<b>HS</b>
R	1150 GS (Tokico cal.)	02 - 05	<b>HS</b>
R	1150 R	01 - 06	<b>HS</b>
R	1150 R Rockster	03 - 05	<b>HS</b>
R	1150 RS	01 - 04	<b>HS</b>
K	1200 LT With Integral		
	ABS	01 - 08	<b>HS</b>
K	1200 R	05 - 08	<b>HS</b>
K	1200 R Sport	05 - 07	<b>HS</b>
R	1200 C Classic	03 - 04	<b>HS</b>
R	1200 C Independent	03 - 04	<b>HS</b>
R	1200 C Montauk	02 - 04	<b>HS</b>
R	1200 CL	03 - 04	<b>HS</b>
R	1200 R	07 - 14	<b>HS</b>
K	1300 R	09 - 15	<b>HS</b>
K	1300 R Dynamic	11 - 15	<b>HS</b>
K	1600 B	17 - 24	<b>HS</b>
K	1600 Grand America	18 - 24	<b>HS</b>
K	1600 GT	11 - 24	<b>HS</b>
K	1600 GTL	11 - 24	<b>HS</b>

STREET HF • HS • LS  
AMERICAN H.HF • H.CT • H.HS • H.LS  
SCOOTER HF • CT • MS

RACING  
OFF ROAD  
ATV

RST • DC • DCC • DS-1 • DS-2 • RQ  
SI • RSI • CS  
ATS • SI • RSI • PSI

Drawings 1:1

Available compounds

HF • CS • SI • RSI

SBS 777

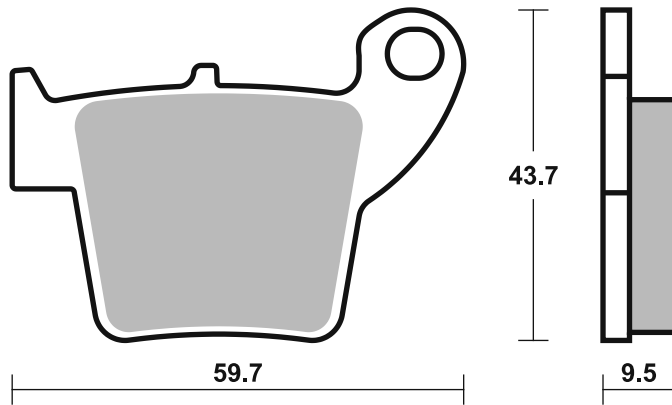
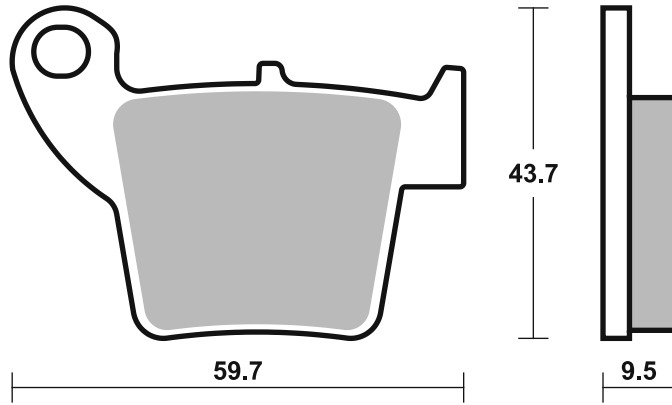

Available compounds

HF • HS • RST

SBS 778

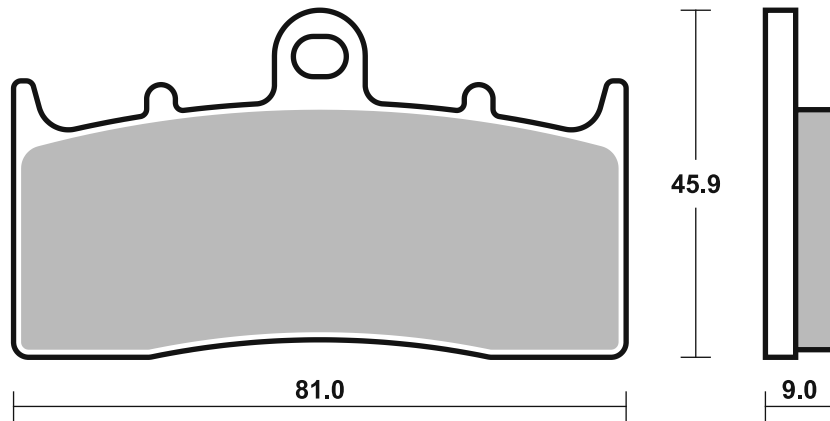



STREET HF • HS • LS  
 AMERICAN H.HF • H.CT • H.HS • H.LS  
 SCOOTER HF • CT • MS

RACING  
 OFF ROAD  
 ATV

RST • DC • DCC • DS-1 • DS-2 • RQ  
 SI • RSI • CS  
 ATS • SI • RSI • PSI

Available compounds

DC

SBS 779

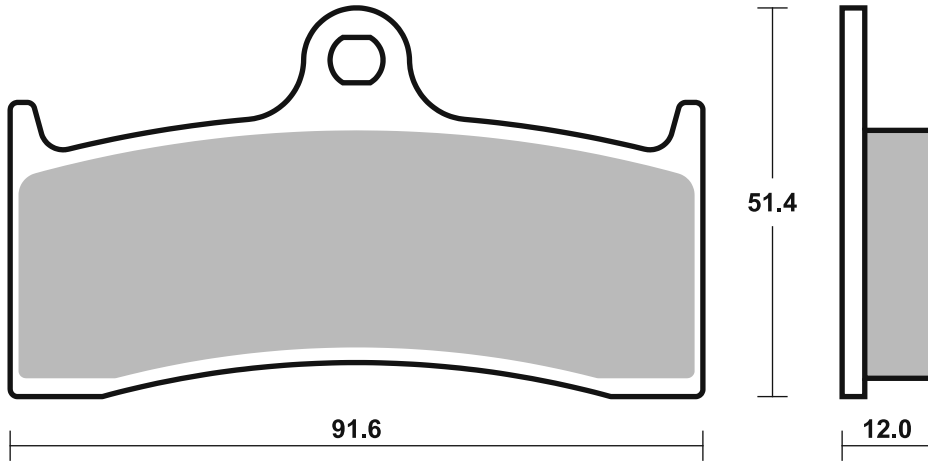

Available compounds

HF

SBS 780

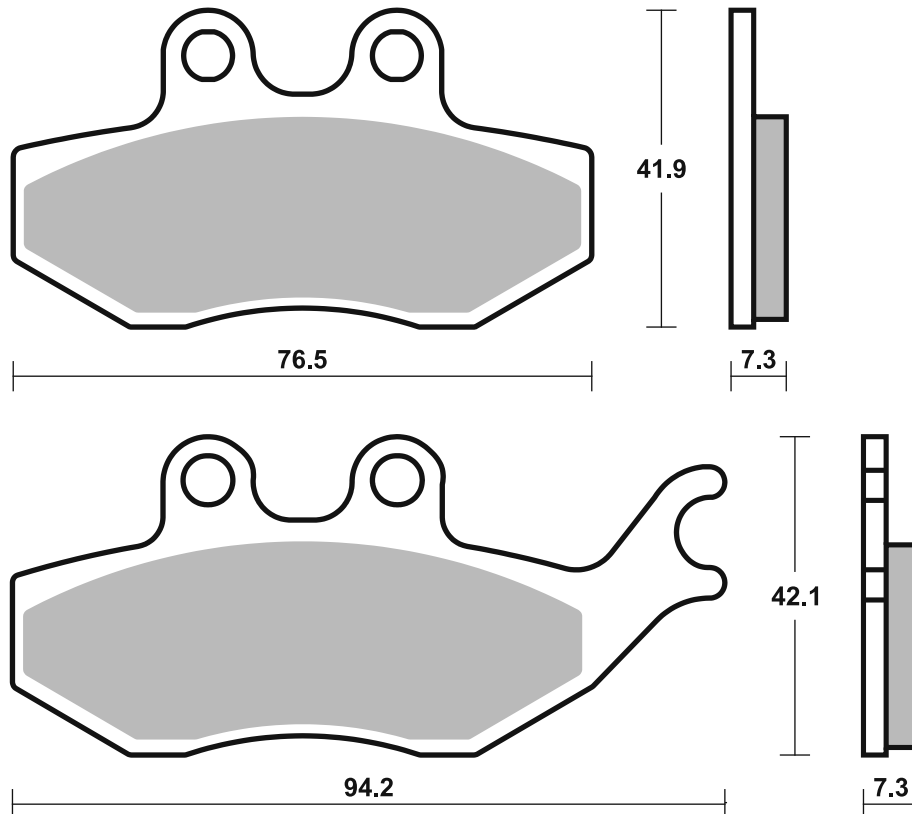





STREET HF • HS • LS  
 AMERICAN H.HF • H.CT • H.HS • H.LS  
 SCOOTER HF • CT • MS

RACING  
 OFF ROAD  
 ATV

RST • DC • DCC • DS-1 • DS-2 • RQ  
 SI • RSI • CS  
 ATS • SI • RSI • PSI

Drawings 1:1

Available compounds

HF • HS • DC • RST • H.HF • H.CT • H.HS

SBS 782

HF / HS - Th. 7.0  
 RST / DC - Th. 8.3

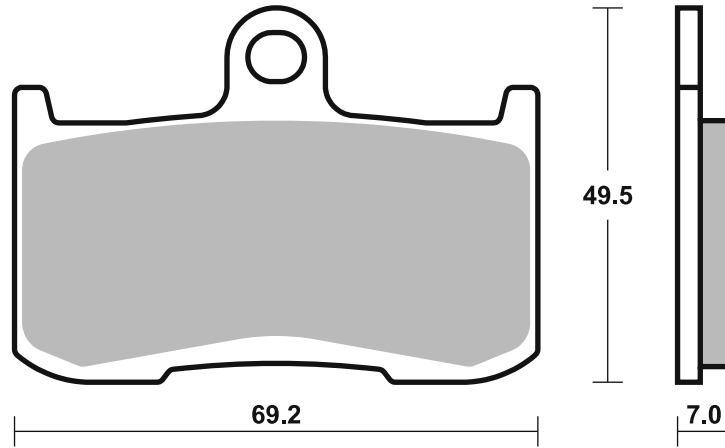

Available compounds

CS • SI • RSI

SBS 783

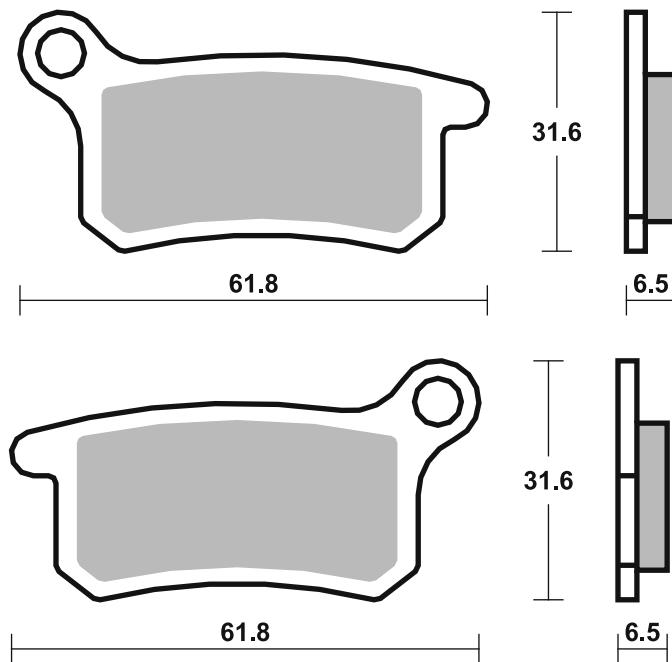

# Applications

## SBS 784

### Recommended compound



#### CF MOTO

	125 Papio	17 - 17	HF
--	-----------	---------	----

#### HONDA

CBR	125 R	03 - 10	HF
-----	-------	---------	----

CT	125 Trail	21 - 21	HF
----	-----------	---------	----

XLV	125 Varadero	01 - 11	HF
-----	--------------	---------	----

Z	125 Monkey	19 - 24	HF
---	------------	---------	----

CBR	150 R	00 - 10	HF
-----	-------	---------	----

#### YAMAHA

YZF	150 R15	14 - 14	HF
-----	---------	---------	----

## SBS 785

### Recommended compound



#### A.P. RACING CALIPERS

CP-4488	Two Pad Radial		
---------	----------------	--	--

	4 Piston Monoblock		
--	--------------------	--	--

STREET  
AMERICAN  
SCOOTER

HF • HS • LS  
H.HF • H.CT • H.HS • H.LS  
HF • CT • MS

RACING  
OFF ROAD  
ATV

RST • DC • DCC • DS-1 • DS-2 • RQ  
SI • RSI • CS  
ATS • SI • RSI • PSI

Drawings 1:1

Available compounds

HF

SBS 784

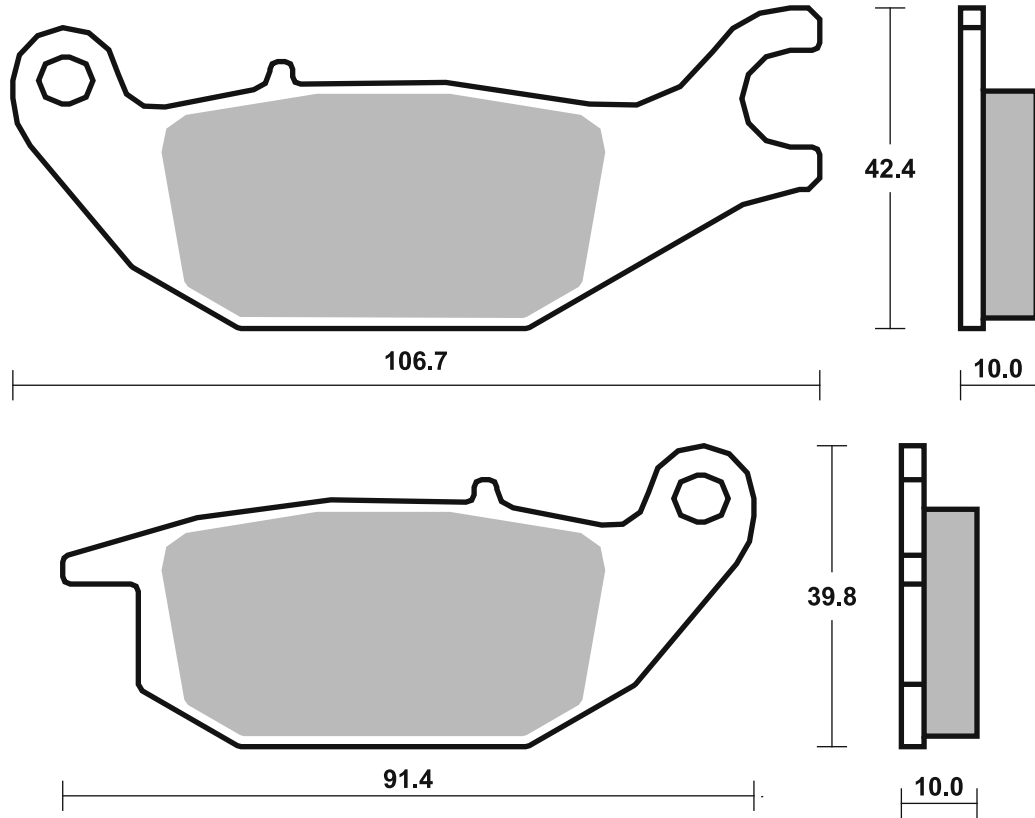

Available compounds

HS • DC

SBS 785

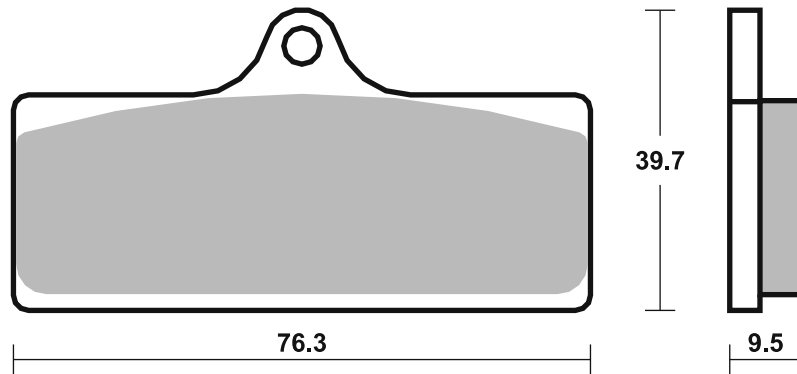

## Applications

### SBS 787 Recommended compound



POLARIS		
325 Xpedition	02 - 02	ATS
330 ATP	06 - 06	ATS
330 E Trail Blazer	08 - 12	ATS
330 Magnum 2x4, 4x4	03 - 13	ATS
450 Sportsman	06 - 09	ATS
500 E Scrambler 2x4, 4x4	08 - 11	ATS
500 Magnum 2x4, 4x4	02 - 07	ATS
500 Predator e	06 - 13	ATS
500 Scrambler 4x4	98 - 13	ATS
500 Sportsman HO (to 15.12.2008)	03 - 08	ATS
600 Sportsman	03 - 06	ATS
700 Sportsman	02 - 09	ATS
700 Sportsman MV 700	05 - 06	ATS



POLARIS		
800 Sportsman (to 15.12.2008)	05 - 08	ATS

### SBS 788 Recommended compound



DERBI		
659 Mulhacen	05 - 05	HS
KAWASAKI		
ZX-6RR 600 Ninja	03 - 06	HS
ZX-6R 636 Ninja	03 - 06	HS
ZX-10R 1000 Ninja	04 - 07	HS
ZX-12R 1200 Ninja	04 - 06	HS
VN 1600 Mean Streak	05 - 05	HS
SUZUKI		
GSX-R 1000	03 - 03	HS
M 1600 Intruder	05 - 07	HS

### SBS 789 Recommended compound



SUZUKI		
C 1500 Intruder	05 - 10	LS
VL 1500 Intruder LC	02 - 02	LS

Brake Pad 1:1 Drawings,  
Compounds, Fitments

STREET HF • HS • LS  
 AMERICAN H.HF • H.CT • H.HS • H.LS  
 SCOOTER HF • CT • MS

RACING  
 OFF ROAD  
 ATV

RST • DC • DCC • DS-1 • DS-2 • RQ  
 SI • RSI • CS  
 ATS • SI • RSI • PSI

Drawings 1:1

Available compounds **SI • RSI • ATS**

**SBS 787**

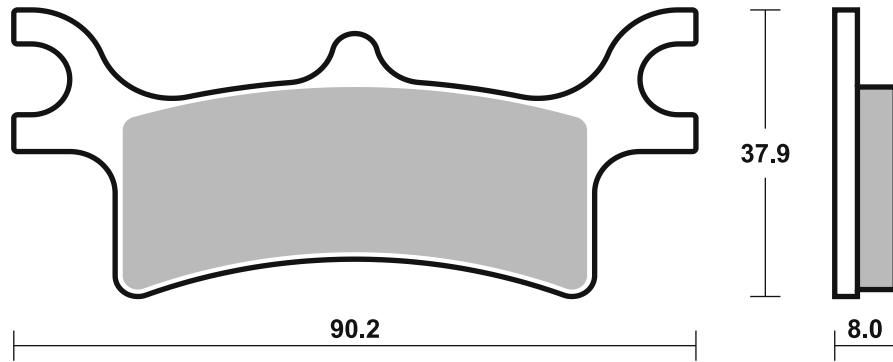

Available compounds **HS • DC • RST • DS-1**

**SBS 788**

1 set = 4 pcs.

HS - Th. 7.9

RST / DC / DS-1 - Th. 9.5

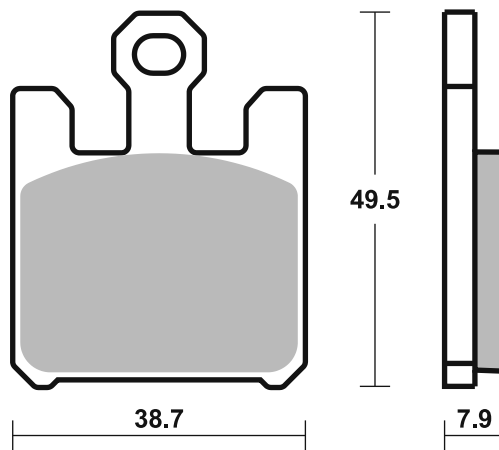

Available compounds **HF • LS**

**SBS 789**

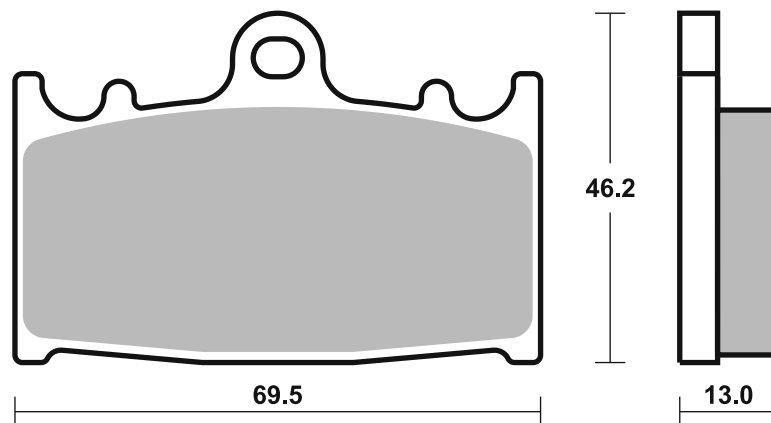



<b>APRILIA</b>			
MXV	450	09 - 13	<b>RSI</b>
RXV	450	06 - 13	<b>SI</b>
SXV	450	06 - 13	<b>RSI</b>
SXV	450 Van den Bosch		
	Rep.	08 - 10	<b>RSI</b>
RXV	550	06 - 13	<b>SI</b>
SXV	550	06 - 13	<b>RSI</b>
SXV	550 Van den Bosch		
	Rep.	08 - 10	<b>RSI</b>
<b>BETA</b>			
RR	125	18 - 19	<b>SI</b>
RR	250	05 - 09	<b>SI</b>
	300 Crosstrainer	15 - 15	<b>SI</b>
RR	300	13 - 19	<b>SI</b>
RR	350 Efi	15 - 15	<b>SI</b>
RR	350 Efi Racing	15 - 15	<b>SI</b>
RR	350 Enduro	12 - 14	<b>SI</b>
RR	390	15 - 19	<b>SI</b>
RR	400 Enduro	05 - 05	<b>SI</b>
RR	430	15 - 19	<b>SI</b>
RR	430 Racing	15 - 19	<b>SI</b>
	450 RX	24 - 24	<b>RSI</b>
RR	450 Cross Country	12 - 12	<b>SI</b>
RR	450 Enduro	05 - 07	<b>SI</b>
RR	480	15 - 19	<b>SI</b>
RR	480 Racing	15 - 19	<b>SI</b>
RR	498 Enduro	12 - 14	<b>SI</b>
RR	525 Enduro	05 - 13	<b>SI</b>
<b>BIMOTA</b>			
BBX	300 Enduro	12 - 12	<b>SI</b>
BX	450	23 - 23	<b>SI</b>
<b>CCM</b>			
	450 MX	08 - 10	<b>RSI</b>
<b>FANTIC</b>			
XE	125	22 - 23	<b>SI</b>
XX	125	20 - 24	<b>RSI</b>
XEF	250	22 - 23	<b>SI</b>
XX	250	22 - 24	<b>RSI</b>
XXF	250	22 - 24	<b>RSI</b>
XE	300	24 - 24	<b>SI</b>
XEF	450	22 - 23	<b>SI</b>
XEF	450 Rally	22 - 23	<b>SI</b>
XXF	450	22 - 24	<b>RSI</b>
<b>GASGAS</b>			
EC	200	17 - 17	<b>SI</b>
XC	200	18 - 19	<b>SI</b>
EC	250	12 - 20	<b>SI</b>
EC	250 Enduro GP 18	18 - 19	<b>SI</b>
XC	250	17 - 19	<b>SI</b>
EC	300	12 - 20	<b>SI</b>
EC	300 Enduro GP 18	18 - 19	<b>SI</b>
XC	300	18 - 19	<b>SI</b>
<b>HM</b>			
CRE	50 Six Comp.	07 - 12	<b>HF</b>
CRM	50 Derapage Comp.	07 - 12	<b>HF</b>
CRE	125 Six Comp.	10 - 11	<b>HF</b>
CRM	125 Derapage		
	Comp. 2T	11 - 12	<b>HF</b>
CRM	125 Derapage		
	Comp. 4T	11 - 12	<b>HF</b>
<b>KAWASAKI</b>			
KX	250	19 - 24	<b>RSI</b>
KX	250 F	04 - 18	<b>RSI</b>



<b>KAWASAKI</b>			
KX	250 X	21 - 24	<b>SI</b>
KLX	450 R	07 - 24	<b>SI</b>
KX	450	19 - 24	<b>RSI</b>
KX	450 F	06 - 18	<b>RSI</b>
KX	450 X	21 - 24	<b>SI</b>
<b>SHERCO</b>			
SE	250 2.5i Enduro	06 - 11	<b>SI</b>
SX	250 2.5i-F	09 - 11	<b>RSI</b>
SE	300 3.0i-F	10 - 11	<b>SI</b>
SE	450 4.5i Enduro	05 - 11	<b>SI</b>
SM	450 4.5i		
	Supermotard	06 - 06	<b>RSI</b>
SE	510 5.1i Enduro	06 - 11	<b>SI</b>
<b>SUZUKI</b>			
RM-Z	250	04 - 24	<b>RSI</b>
RMX	450 Z	10 - 18	<b>SI</b>
RM-Z	450	05 - 24	<b>RSI</b>
<b>TM</b>			
EN	125 Enduro	05 - 22	<b>SI</b>
MX	125	05 - 24	<b>RSI</b>
MX	144	08 - 24	<b>RSI</b>
EN	250 Enduro	05 - 22	<b>SI</b>
EN	250 F Enduro	05 - 22	<b>SI</b>
MX	250	05 - 24	<b>RSI</b>
MX	250 F	05 - 24	<b>RSI</b>
EN	300 Enduro	05 - 05	<b>SI</b>
FT	300	17 - 19	<b>RSI</b>
MX	300	05 - 24	<b>RSI</b>
EN	450 F Enduro	05 - 22	<b>SI</b>
FT	450 Fi	17 - 19	<b>RSI</b>
MX	450 F	05 - 24	<b>RSI</b>
EN	530 F Enduro	05 - 05	<b>SI</b>
FT	530 Fi	17 - 19	<b>RSI</b>
MX	530 F	05 - 24	<b>RSI</b>
<b>YAMAHA</b>			
YZ	125	03 - 21	<b>RSI</b>
WR	250 F	03 - 13	<b>SI</b>
WR	250 F Efi	15 - 21	<b>SI</b>
WR	250 F Enduro GP	18 - 18	<b>SI</b>
WR	250 R	08 - 20	<b>LS</b>
WR	250 X	08 - 16	<b>LS</b>
YZ	250	03 - 21	<b>RSI</b>
YZ	250 F	03 - 20	<b>RSI</b>
YZ	250 FX	15 - 21	<b>SI</b>
WR	450 F	03 - 20	<b>SI</b>
YZ	450 F	03 - 19	<b>RSI</b>
YZ	450 FX	16 - 22	<b>SI</b>
<b>ZERO</b>			
DS	ZF11.4	13 - 13	<b>LS</b>
DS	ZF8.5	13 - 13	<b>LS</b>
FX	ZF2.8	13 - 13	<b>LS</b>
FX	ZF5.7	13 - 13	<b>LS</b>
MX	ZF2.8	13 - 13	<b>RSI</b>
MX	ZF5.7	13 - 13	<b>RSI</b>
S	ZF11.4	13 - 13	<b>LS</b>
S	ZF8.5	13 - 13	<b>LS</b>
XU	ZF2.8	13 - 13	<b>LS</b>
XU	ZF5.7	13 - 13	<b>LS</b>

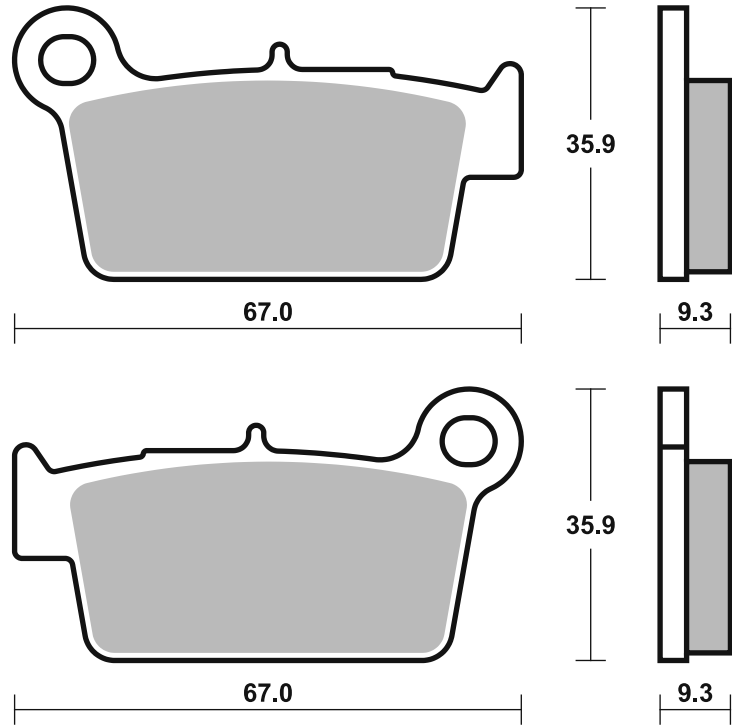



<b>BMW</b>			
G	450 SMR	09 - 10	<b>RSI</b>
G	450 X	08 - 10	<b>SI</b>

**BREMBO RACING CALIPERS**

Off Road XQ21390, PF 26

**GASGAS**

MC	65	23 - 24	<b>RSI</b>	<b>RSI</b>
MC	85	21 - 24	<b>RSI</b>	<b>RSI</b>
MC	125	21 - 24	<b>RSI</b>	<b>RSI</b>
EC	200 Ranger Enduro	19 - 19	<b>SI</b>	
EC	250	21 - 23	<b>SI</b>	
EC	250 F	21 - 23	<b>SI</b>	
MC	250	21 - 24	<b>RSI</b>	
MC	250 F	21 - 24	<b>RSI</b>	
EC	300	21 - 23	<b>SI</b>	
EC	300 Ranger Enduro	19 - 19	<b>SI</b>	
EC	350 F	21 - 23	<b>SI</b>	
MC	350 F	22 - 24	<b>RSI</b>	
MC	450 F	21 - 24	<b>RSI</b>	
RX	450 F	23 - 23	<b>SI</b>	

**HUSABERG**

TE	125	13 - 13	<b>SI</b>	
FE	250	13 - 13	<b>SI</b>	
TE	250	11 - 13	<b>SI</b>	
TE	300	11 - 13	<b>SI</b>	
FE	350	13 - 13	<b>SI</b>	
FE	390	10 - 13	<b>SI</b>	
FE	450	09 - 13	<b>SI</b>	
FE	501	13 - 13	<b>SI</b>	
FE	570	09 - 13	<b>SI</b>	

**HUSQVARNA**

TC	65	23 - 24	<b>RSI</b>	<b>RSI</b>
TC	85	21 - 24	<b>RSI</b>	<b>RSI</b>
CR	125	05 - 13	<b>RSI</b>	<b>RSI</b>
TC	125	14 - 24	<b>RSI</b>	<b>RSI</b>
TE	125	14 - 16	<b>SI</b>	
TX	125	17 - 19	<b>SI</b>	
TE	150 i	20 - 23	<b>SI</b>	
CR	250	05 - 05	<b>RSI</b>	<b>RSI</b>
FC	250	14 - 24	<b>RSI</b>	<b>RSI</b>
FE	250	14 - 23	<b>SI</b>	
TC	250	04 - 24	<b>RSI</b>	<b>RSI</b>
TE	250	14 - 18	<b>SI</b>	
TE	250 4T	10 - 13	<b>SI</b>	
TE	250 i	20 - 23	<b>SI</b>	
TC	300	14 - 15	<b>RSI</b>	<b>RSI</b>
TE	300	14 - 19	<b>SI</b>	
TE	300 i	18 - 23	<b>SI</b>	
TE	300 Pro	24 - 24	<b>SI</b>	
WR	300	09 - 13	<b>SI</b>	
TE	310 4T	10 - 13	<b>SI</b>	
FC	350	14 - 24	<b>RSI</b>	<b>RSI</b>
FE	350	14 - 23	<b>SI</b>	
FE	350 Pro	24 - 24	<b>SI</b>	
SMR	449	11 - 13	<b>RSI</b>	<b>RSI</b>
TC	449	11 - 13	<b>RSI</b>	<b>RSI</b>
TE	449	11 - 13	<b>SI</b>	
FC	450	14 - 24	<b>RSI</b>	<b>RSI</b>
FE	450	14 - 23	<b>SI</b>	
FR	450 Rally	22 - 23	<b>SI</b>	
FS	450	15 - 22	<b>RSI</b>	<b>RSI</b>
FX	450	17 - 20	<b>SI</b>	
SM	450 R	06 - 13	<b>RSI</b>	<b>RSI</b>
SM	450 RR	06 - 10	<b>RSI</b>	<b>RSI</b>
TC	450	04 - 10	<b>RSI</b>	<b>RSI</b>
TE	450	14 - 14	<b>SI</b>	
FE	501	14 - 23	<b>SI</b>	



<b>HUSQVARNA</b>			
SM	510 Centennial	06 - 06	<b>RSI</b>
SM	510 R	06 - 10	<b>RSI</b>
TC	510	04 - 10	<b>RSI</b>
SMR	511	11 - 13	<b>RSI</b>
TE	511	11 - 14	<b>SI</b>
SM	610 ie	07 - 10	<b>RSI</b>
SM	630	10 - 10	<b>HF</b>
TE	630	10 - 13	<b>HF</b>
TE	630	14 - 14	<b>SI</b>
STR	650 CRC	07 - 07	<b>HF</b>

**KTM**

SX	65	23 - 24	<b>RSI</b>	<b>RSI</b>
SX	85 (17/14)	21 - 24	<b>RSI</b>	<b>RSI</b>
SX	85 (19/16)	21 - 24	<b>RSI</b>	<b>RSI</b>
EXC	125 Enduro	04 - 15	<b>SI</b>	
SX	125	04 - 24	<b>RSI</b>	
SX	144	07 - 08	<b>RSI</b>	
EXC	150 TPI	20 - 23	<b>SI</b>	
SX	150	09 - 23	<b>RSI</b>	
XC-W	150	17 - 23	<b>SI</b>	
EXC	200 Enduro	04 - 16	<b>SI</b>	
SX	200	03 - 04	<b>RSI</b>	
EXC	250 Enduro	04 - 08	<b>SI</b>	
EXC	250 Enduro 4T	04 - 06	<b>SI</b>	
EXC	250 TPI	18 - 23	<b>SI</b>	
EXC-F	250	07 - 23	<b>SI</b>	
SX	250	03 - 24	<b>RSI</b>	
SX-F	250	06 - 24	<b>RSI</b>	
XC	250	06 - 14	<b>RSI</b>	
EXC	300 Enduro	04 - 08	<b>SI</b>	
EXC	300 TPI	18 - 23	<b>SI</b>	
SX	300	23 - 24	<b>RSI</b>	
XC	300	06 - 14	<b>RSI</b>	
EXC-F	350	11 - 23	<b>SI</b>	
SX-F	350	11 - 24	<b>RSI</b>	
EXC	400 Racing	04 - 07	<b>SI</b>	
	450 Rally	19 - 22	<b>SI</b>	
EXC-F	450	04 - 23	<b>SI</b>	
SX	450 SM Factory			
	Replica	04 - 07	<b>RSI</b>	
SX	450 SMR	04 - 22	<b>RSI</b>	
SX	450 SMR	21 - 22	<b>RSI</b>	
SX-F	450	03 - 24	<b>RSI</b>	
XC-F	450	06 - 23	<b>RSI</b>	
EXC-F	500	12 - 24	<b>SI</b>	
SX	505	07 - 09	<b>RSI</b>	
SX-F	505	07 - 08	<b>RSI</b>	
XC-F	505	08 - 09	<b>RSI</b>	
EXC	525 Racing	04 - 06	<b>SI</b>	
SX	525 SMR	04 - 07	<b>RSI</b>	
SX-F	525	04 - 06	<b>RSI</b>	
EXC	530 Racing	08 - 11	<b>SI</b>	
SX	560 SMR	06 - 07	<b>RSI</b>	

**RIEJU**

MRX	250 Marathon	10 - 12	<b>SI</b>	
MRX	450 Marathon	08 - 12	<b>SI</b>	

**SHERCO**

SE-R	125	17 - 19	<b>SI</b>	
SE	250 , R	14 - 14	<b>SI</b>	
SE	250 F, F-R	14 - 19	<b>SI</b>	
SE	250 i/iR	12 - 13	<b>SI</b>	
SE	250 i-F	13 - 13	<b>SI</b>	
SCF-R	300	16 - 19	<b>SI</b>	
SE	300 , R	14 - 19	<b>SI</b>	
SE	300 F, F-R	14 - 19	<b>SI</b>	
SE	300 i/iR	12 - 13	<b>SI</b>	
SE	300 i-F	13 - 13	<b>SI</b>	



<b>SHERCO</b>			
SE	450 F, F-R	14 - 19	<b>SI</b>
SE	450 iR	12 - 13	<b>SI</b>
SE	510 iR	12 - 13	<b>SI</b>

**STARK**

	Varg	23 - 24	<b>RSI</b>
--	------	---------	------------

**SWM**

	125 Gran Milano		
	Outlaw	20 - 20	<b>HF</b>
RS	300 R	15 - 20	<b>SI</b>
	400 Varez	20 - 20	<b>HF</b>
SM	450 R	15 - 17	<b>HF</b>
RS	500 R	15 - 20	<b>SI</b>
SM	500 R	18 - 20	<b>HF</b>

**TRIUMPH**

TF	250 X	24 - 24	<b>RSI</b>
----	-------	---------	------------

**WRM**

	450 MX	06 - 08	<b>RSI</b>
--	--------	---------	------------



STREET HF • HS • LS  
AMERICAN H.HF • H.CT • H.HS • H.LS  
SCOOTER HF • CT • MS

RACING  
OFF ROAD  
ATV

RST • DC • DCC • DS-1 • DS-2 • RQ  
SI • RSI • CS  
ATS • SI • RSI • PSI

Drawings 1:1

Available compounds

HF • CS • SI • RSI

SBS 791

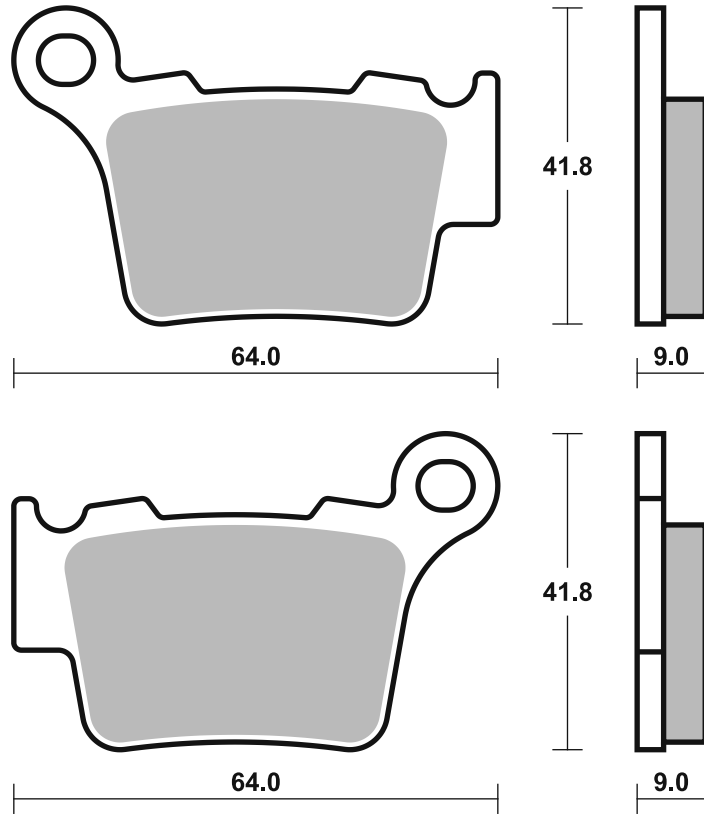



STREET HF • HS • LS  
 AMERICAN H.HF • H.CT • H.HS • H.LS  
 SCOOTER HF • CT • MS

RACING  
 OFF ROAD  
 ATV

RST • DC • DCC • DS-1 • DS-2 • RQ  
 SI • RSI • CS  
 ATS • SI • RSI • PSI

Drawings 1:1

Available compounds

HF

SBS 792

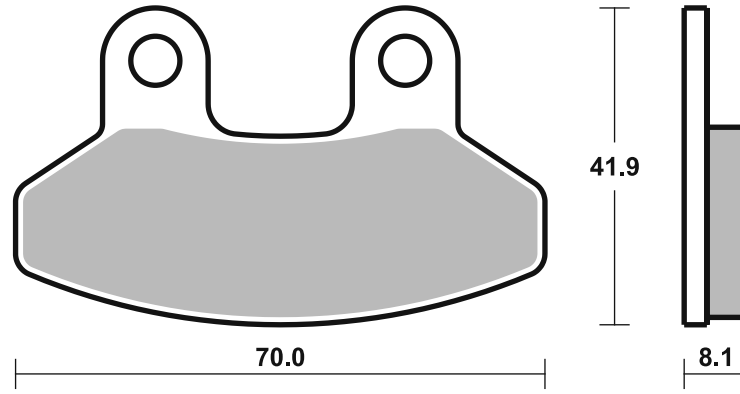

Available compounds

SI • RSI

SBS 794

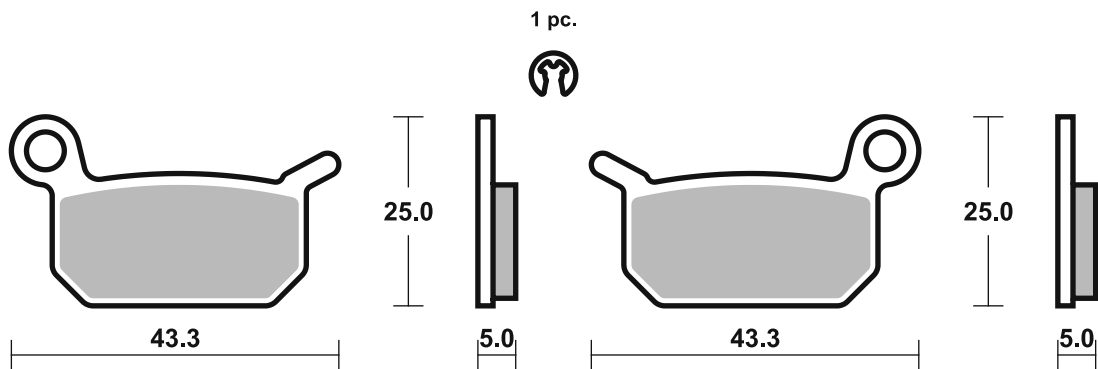

Available compounds

HF • HS

SBS 795

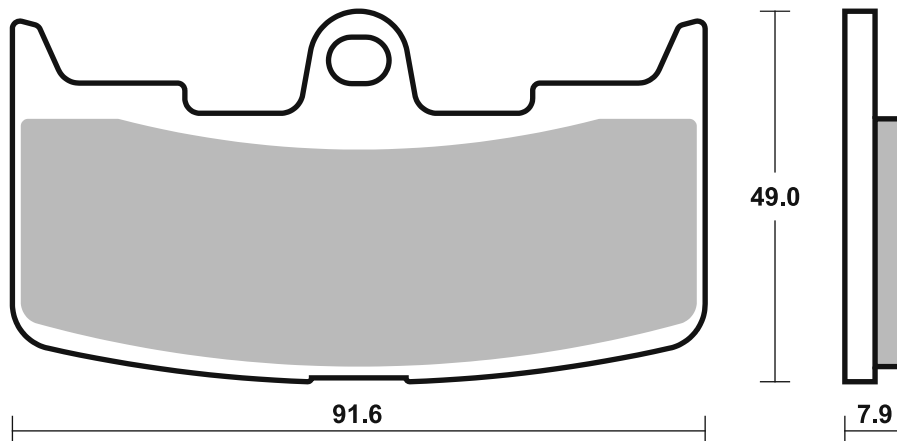



STREET HF • HS • LS  
 AMERICAN H.HF • H.CT • H.HS • H.LS  
 SCOOTER HF • CT • MS

RACING  
 OFF ROAD  
 ATV

RST • DC • DCC • DS-1 • DS-2 • RQ  
 SI • RSI • CS  
 ATS • SI • RSI • PSI

Available compounds HF • HS • RST

SBS 796

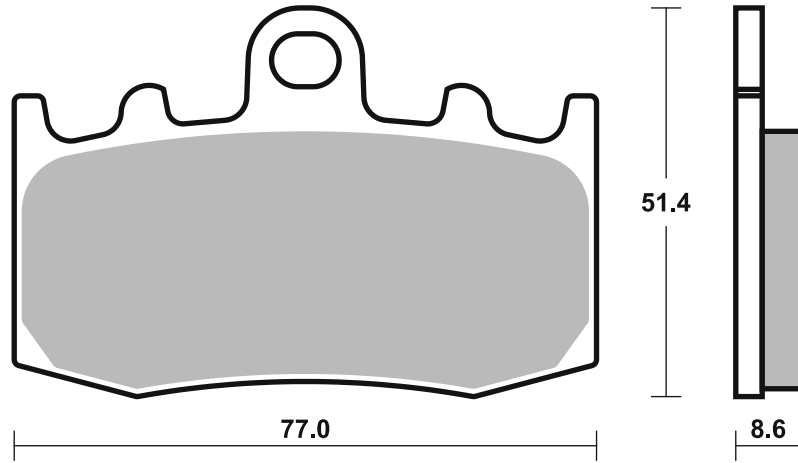

Available compounds HF • HS • RSI

SBS 797

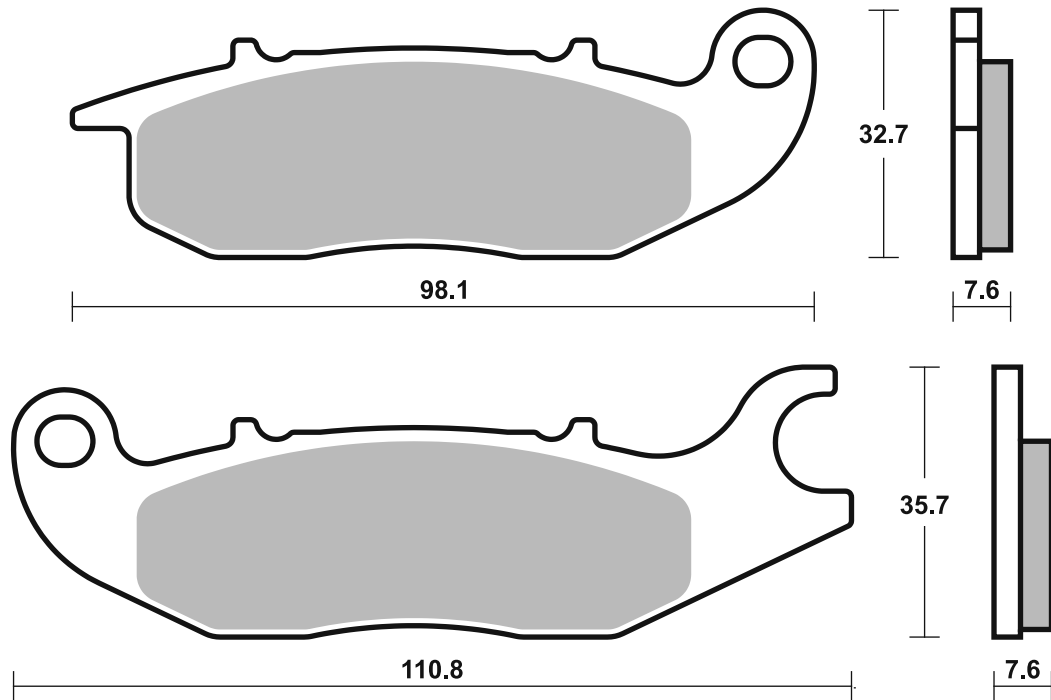

## Applications

### SBS 798

### Recommended compound



#### KAWASAKI

KFX	450	07 - 15	SI
KVF	650 Brute Force 4x4	05 - 11	SI
KVF	650 Prairie	01 - 03	SI
KFX	700 V-Force	04 - 13	SI
KSV	700 V-Force	04 - 11	SI
KVF	700 Prairie	04 - 13	SI

#### SUZUKI

LT-V	700 Quadrunner		
	Twin Peaks	04 - 06	SI

### SBS 799

### Recommended compound



#### CF MOTO

	400 C-Force	18 - 21	SI
	450 C-Force L	16 - 17	SI
	450 G-Force L	16 - 17	SI
	500 C-Force HO	18 - 18	SI
	500 C-Force S	18 - 21	SI
CF	500 Terralander	13 - 15	SI
	550 C-Force	16 - 17	SI
	600 C-Force	19 - 19	SI
CF	625 Terralander	11 - 15	SI
CF	800 Terralander	12 - 14	SI

#### GOES

	520 Max	07 - 12	SI
G	520	07 - 12	SI
G	525	12 - 14	SI
G	620	11 - 14	SI
G	625 A	12 - 14	SI

#### YAMAHA

YFM	660 FWAP 4x4 Grizzly	02 - 08	SI
-----	----------------------	---------	----

STREET HF • HS • LS  
AMERICAN H.HF • H.CT • H.HS • H.LS  
SCOOTER HF • CT • MS

RACING  
OFF ROAD  
ATV

RST • DC • DCC • DS-1 • DS-2 • RQ  
SI • RSI • CS  
ATS • SI • RSI • PSI

Drawings 1:1

Available compounds

SI • RSI

SBS 798

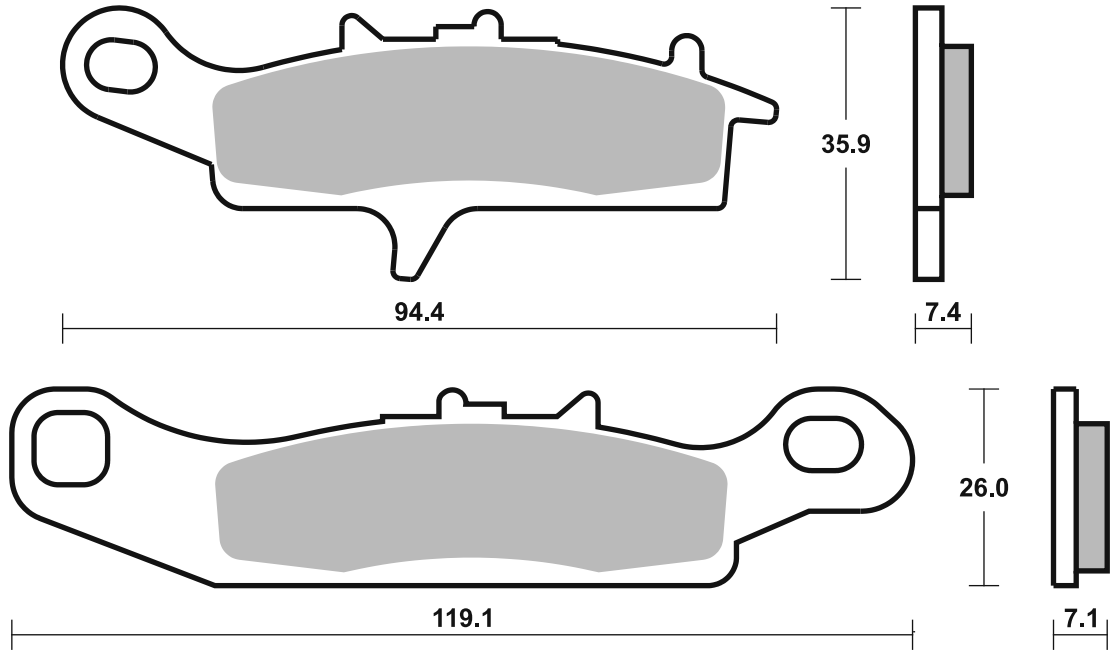

Available compounds

SI • RSI

SBS 799

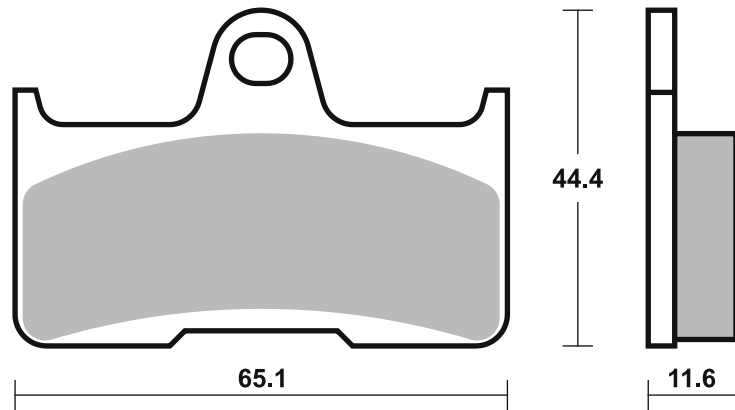





STREET HF • HS • LS  
 AMERICAN H.HF • H.CT • H.HS • H.LS  
 SCOOTER HF • CT • MS

RACING  
 OFF ROAD  
 ATV

RST • DC • DCC • DS-1 • DS-2 • RQ  
 SI • RSI • CS  
 ATS • SI • RSI • PSI

Drawings 1:1

Available compounds

SI • RSI • ATS

SBS 800

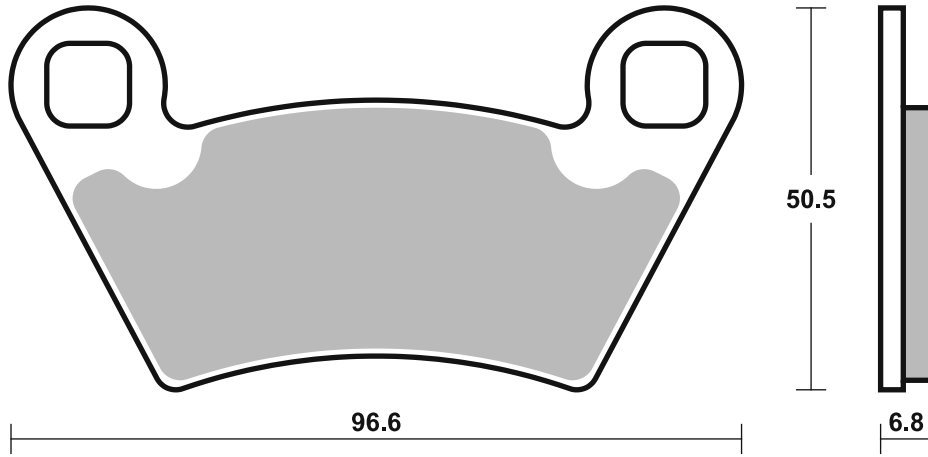

Available compounds

SI • RSI

SBS 801

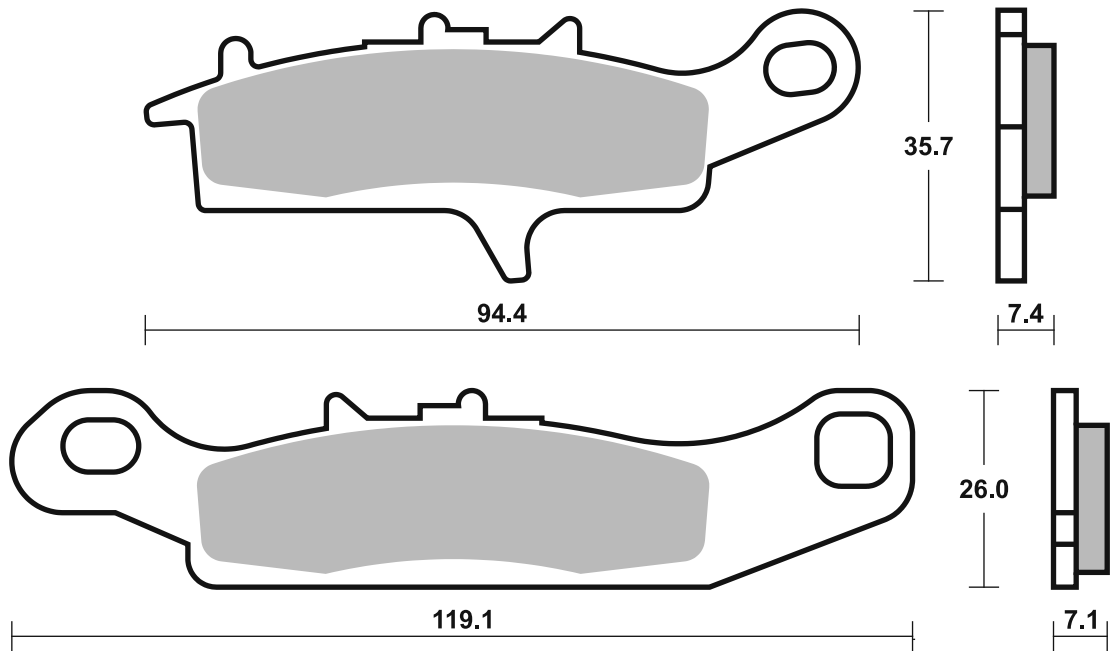

## Applications

### SBS 802

### Recommended compound



<b>AJP</b>			
PR3	125 Enduro	08 - 12	HF
PR3	125 Supermotard	08 - 12	HF
PR4	125 Enduro	04 - 12	HF
PR4	125 Supermotard	04 - 09	HF
PR3	200 Enduro	08 - 12	HF
PR3	200 Supermotard	08 - 12	HF
PR4	200 Enduro	04 - 04	HF
PR4	200 Supermotard	04 - 04	HF
<b>BETA</b>			
	80 EVO	09 - 10	RSI
	80 Rev	08 - 10	RSI
	125 EVO	09 - 14	RSI
	125 Rev 3	00 - 08	RSI RSI
	125 Rev 3	06 - 08	RSI
	200 EVO	09 - 14	RSI
	200 Rev 3	06 - 08	RSI
	250 4-T Rev 3	07 - 11	RSI
	250 EVO (2-T / 4-T)	09 - 14	RSI
	250 Rev 3	00 - 09	RSI RSI
	250 Rev 3	05 - 09	RSI
	270 Rev 3	00 - 08	RSI RSI
	270 Rev 3	05 - 08	RSI
	290 EVO	09 - 13	RSI



<b>BETA</b>			
	300 EVO	09 - 15	RSI
<b>GASGAS</b>			
TX	125 Randone	12 - 13	RSI
TXT	125	04 - 13	RSI
TXT	200	04 - 10	RSI
TXT	250	04 - 07	RSI
TXT	280	04 - 04	RSI
TXT	300	04 - 06	RSI
TXT	300 Pro	07 - 11	RSI
<b>HONDA</b>			
Cota	250 4RT	04 - 16	RSI
Cota	260 4RT	04 - 24	RSI
<b>MONTESA</b>			
	250 Cota 4RT	04 - 16	RSI
Cota	260 4RT	04 - 24	RSI
	360 315R	01 - 04	RSI
<b>OSSA</b>			
TR	125 i	15 - 15	RSI
TR	250 i	15 - 15	RSI
TR	280 i	10 - 15	RSI



<b>OSSA</b>			
TR	280 i Explorer	12 - 15	RSI
TR	300 i	15 - 15	RSI
<b>SCORPA</b>			
SY	115 F Trial	06 - 06	RSI
	125 Twenty Trial	16 - 18	RSI
SY	125 F Trial	06 - 11	RSI
	250 Twenty Trial	16 - 18	RSI
SY	250 F Trial	06 - 11	RSI
SY	250 Trial	00 - 01	RSI
	300 Twenty Trial	16 - 18	RSI
<b>SHERCO</b>			
ST	125 1.25	06 - 11	RSI
ST	250 2.5	01 - 01	RSI
ST	290 2.9	01 - 01	RSI
ST	300	16 - 19	RSI
ST	320 3.2F	05 - 05	RSI
<b>TRS</b>			
	250 ONE	16 - 19	RSI
	280 ONE	16 - 19	RSI
	300 ONE	16 - 19	RSI

### SBS 803

### Recommended compound



<b>APRILIA</b>			
	50 Mini RX	04 - 04	RSI
<b>BETA</b>			
	50 ProRace 12/10	04 - 04	RSI RSI
<b>FACTORY</b>			
R12	50 Phantom Agua	06 - 06	RSI
R14	50 Phantom Agua	04 - 04	RSI
R2	65 Phantom	04 - 04	RSI
<b>GASGAS</b>			
TX	125 Randone	12 - 13	RSI
TXT	125	04 - 13	RSI
TXT	125 (Formula cal.)	12 - 13	RSI
TXT	125 GP	19 - 23	RSI
TXT	125 Pro Racing	14 - 14	RSI
TXT	125 Pro Replica	13 - 13	RSI
TXT	125 Racing	19 - 23	RSI
TXT	200	04 - 10	RSI
TXT	250	04 - 07	RSI
TXT	250 (Formula cal.)	12 - 13	RSI
TXT	250 GP	19 - 23	RSI
TXT	250 Pro Racing	14 - 19	RSI
TXT	250 Pro Replica	13 - 14	RSI
TXT	250 Racing	19 - 23	RSI
TXT	280	04 - 04	RSI
TXT	280 (Formula cal.)	12 - 12	RSI
TXT	280 GP	19 - 23	RSI
TXT	280 Pro Racing	14 - 19	RSI
TXT	280 Pro Replica	13 - 13	RSI
TXT	280 Racing	19 - 23	RSI
TXT	300	04 - 06	RSI
TXT	300 (Formula cal.)	12 - 12	RSI
TXT	300 GP	19 - 23	RSI
TXT	300 Pro	07 - 11	RSI
TXT	300 Pro Racing	14 - 19	RSI
TXT	300 Pro Replica	13 - 13	RSI
TXT	300 Racing	19 - 23	RSI



<b>HONDA</b>			
Cota	250 4RT	04 - 16	RSI
Cota	260 4Ride	16 - 24	RSI
Cota	260 4RT	04 - 24	RSI
Cota	260 4RT Race Replica	15 - 24	RSI
Cota	300 RR	16 - 19	RSI
Cota	301 RR	20 - 24	RSI
Cota	301 RR Race Replica	20 - 24	RSI
<b>HUSQVARNA</b>			
CR	50 Junior	06 - 06	RSI
CR	50 Pro Senior	06 - 06	RSI
CR	50 Senior	06 - 06	RSI
SM	50	10 - 12	RSI
<b>JOTAGAS</b>			
JT	125	14 - 19	RSI
JT	250	14 - 19	RSI
JT	280	14 - 19	RSI
JT	300	14 - 19	RSI
<b>MACBOR</b>			
XC	50 510 Racing	04 - 04	RSI
XC	50 512 Pro	04 - 04	RSI
XC	50 512 Racing	04 - 04	RSI
XC	50 512 T	04 - 04	RSI
XC	50 515 R 6V	04 - 04	RSI
<b>MONTESA</b>			
	250 Cota 4RT	04 - 16	RSI
Cota	260 4Ride	16 - 24	RSI
Cota	260 4RT	04 - 24	RSI
Cota	260 4RT Race Replica	15 - 24	RSI
Cota	300 RR	16 - 19	RSI
Cota	301 RR	20 - 24	RSI
Cota	301 RR Race Replica	20 - 24	RSI
	360 315R	01 - 04	RSI



<b>OSSA</b>			
TR	125 i	15 - 15	RSI
TR	250 i	15 - 15	RSI
TR	280 i	10 - 15	RSI
TR	280 i Explorer	12 - 15	RSI
TR	300 Factory R	15 - 15	RSI
TR	300 i	15 - 15	RSI
<b>SCORPA</b>			
SY	115 F Trial	06 - 06	RSI
TY-S	115 F Trial	06 - 06	RSI
	125 Twenty Trial	16 - 18	RSI
SY	125 F Trial	06 - 11	RSI
TY-S	125 F Trial	06 - 08	RSI
	250 Twenty Trial	16 - 18	RSI
SY	250 F Trial	06 - 11	RSI
SY	250 Trial	00 - 01	RSI
	300 Twenty Trial	16 - 18	RSI
<b>SHERCO</b>			
ST	80 (Formula cal.)	13 - 14	RSI
ST	125 (Formula cal.)	13 - 14	RSI
ST	125 1.25	06 - 11	RSI
ST	250 (Formula cal.)	13 - 14	RSI
ST	250 2.5	01 - 01	RSI
ST	290 (Formula cal.)	13 - 14	RSI
ST	290 2.9	01 - 01	RSI
ST	300	16 - 19	RSI
ST	305 (Formula cal.)	13 - 14	RSI
ST	320 3.2F	05 - 05	RSI
<b>TRS</b>			
	125 ONE	19 - 20	RSI
	125 RR ONE	19 - 20	RSI
	250 ONE	16 - 19	RSI
	250 RR ONE	19 - 20	RSI
	280 ONE	16 - 19	RSI
	280 RR ONE	19 - 20	RSI
	300 ONE	16 - 19	RSI

STREET  
AMERICAN  
SCOOTER

HF • HS • LS  
H.HF • H.CT • H.HS • H.LS  
HF • CT • MS

RACING  
OFF ROAD  
ATV

RST • DC • DCC • DS-1 • DS-2 • RQ  
SI • RSI • CS  
ATS • SI • RSI • PSI

Drawings 1:1

Available compounds

HF • RSI

SBS 802

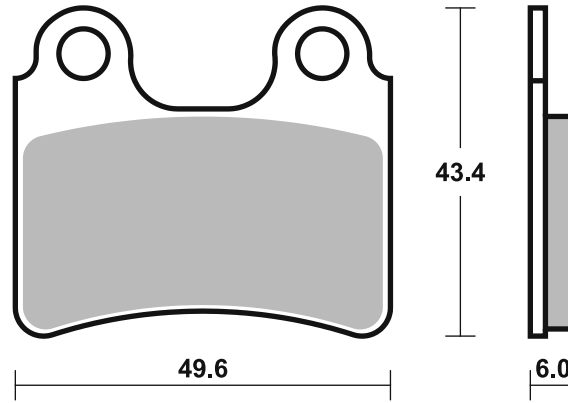

Available compounds

HF • RSI

SBS 803

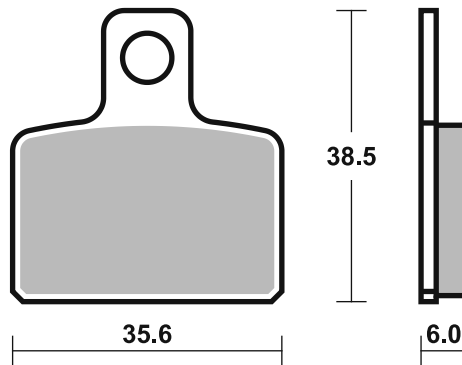

# Applications

## SBS 803 Recommended compound



TRS		
300 RR ONE	19 - 20	RSI

VERTIGO		
300 Combat Camo Works	15 - 19	RSI
300 Combat Ice Hell	15 - 19	RSI
300 Combat RR	15 - 19	RSI

## SBS 805 Recommended compound



A.P. RACING CALIPERS	
CP-6688 Four Pad Radial	4 Piston Monoblock

ACCOSSATO	
AGPZ01, 108 mm CNC Monoblock,	4 Piston/4 Pad
AGPZ02, 108 mm Forged Monoblock,	4 Piston/4 Pad
AGPZ03, 108 mm Forged Monoblock,	4 Piston/4 Pad
AGPZ04, 108 mm Forged Monoblock,	4 Piston/4 Pad
AGPZ06, 60 mm CNC Moto 3,	2 Piston/2 Pad

BREMBO RACING CALIPERS	
Radial Monoblock X99C460/61,	P4 34



PVM	
4 Pad Caliper	

## SBS 806 Recommended compound



KAWASAKI			
ZX-25R	250	20 - 23	HS
ZX-4R	400	23 - 24	HS
ZX-4R	400 SE	23 - 24	HS
ZX-4RR	400	23 - 24	HS
Z	900 RS	18 - 24	HS
Z	900 RS Cafe	18 - 21	HS
Z	1000 Ninja SX	20 - 24	HS
KLE	1000 Versys	19 - 24	HS
KLE	1000 Versys ABS	19 - 24	HS
KLE	1000 Versys S	21 - 24	HS
KLE	1000 Versys SE	19 - 24	HS
Z	1000	10 - 16	HS
Z	1000 ABS	15 - 19	HS
Z	1000 SE	14 - 16	HS
Z	1000 SX	11 - 23	HS
ZX	1000 H2 SX	18 - 24	HS
ZX	1000 H2 SX SE	18 - 24	HS
ZX-10R	1000 Ninja	08 - 15	HS



SUZUKI			
GSX-R	600	04 - 10	HS
GSX-R	750	04 - 10	HS
GSX-S	950	22 - 24	HS
DL	1000 V-Strom	14 - 19	HS
DL	1000 V-Strom XT	17 - 19	HS
DL	1000 V-Strom XT Adventure	19 - 19	HS
GSX-R	1000	04 - 08	HS
DL	1050 V-Strom	20 - 24	HS
DL	1050 V-Strom DE	23 - 24	HS
DL	1050 V-Strom XT	20 - 24	HS
GSX-R	1300 Hayabusa	08 - 12	HS
M	1800 R Intruder	06 - 16	HS
M	1800 R2 Intruder	08 - 10	HS
M	1800 RBZ Intruder	16 - 17	HS

STREET  
AMERICAN  
SCOOTER

HF • HS • LS  
H.HF • H.CT • H.HS • H.LS  
HF • CT • MS

RACING  
OFF ROAD  
ATV

RST • DC • DCC • DS-1 • DS-2 • RQ  
SI • RSI • CS  
ATS • SI • RSI • PSI

Drawings 1:1

Available compounds

HF • RSI

SBS 803

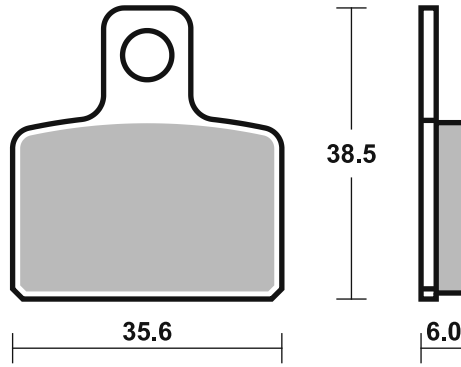

Available compounds

DC • DS-1 • DS-2

SBS 805

1 set = 4 pcs.

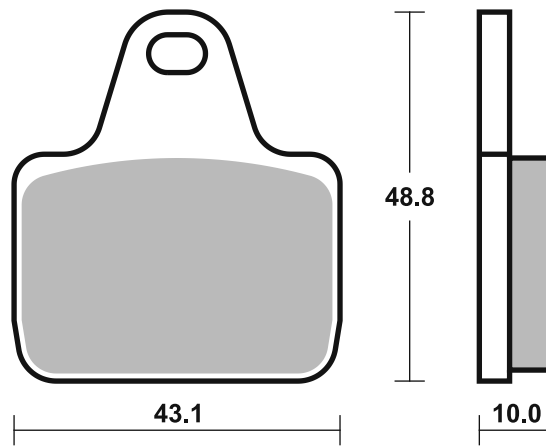

Available compounds

HS • DC • RST • DS-1 • DS-2

SBS 806

HS - Th. 8.0  
RST / DC / DS-1 / DS-2 - Th. 9.0

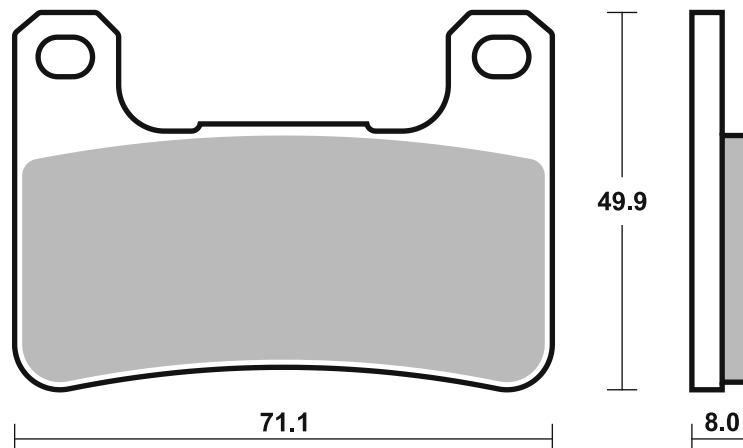

Applications

**SBS 807** Recommended compound



<b>HARLEY DAVIDSON</b>			
XL	883 C Sportster		
	Custom	04 - 13	<b>H.HS</b>
XL	883 L Sportster Low	06 - 13	<b>H.HS</b>
XL	883 L Super Low	11 - 13	<b>H.HS</b>
XL	883 N Iron	13 - 13	<b>H.HS</b>
XL	883 R Roadster	10 - 13	<b>H.HS</b>
XL	883 Sportster	04 - 13	<b>H.HS</b>
XL	883 Sportster R	05 - 13	<b>H.HS</b>
XL	1200 C Sportster		
	Custom	04 - 13	<b>H.HS</b>
XL	1200 L Sportster Low	07 - 10	<b>H.HS</b>
XL	1200 N Nightster	07 - 12	<b>H.HS</b>
XL	1200 R Sportster		
	Roadster	04 - 09	<b>H.HS</b>
XL	1200 V Seventy-Two	11 - 13	<b>H.HS</b>
XL	1200 X Forty-Eight	11 - 13	<b>H.HS</b>

**SBS 808** Recommended compound



<b>HARLEY DAVIDSON</b>			
XL	883 C Sportster		
	Custom	04 - 13	<b>H.LS</b>
XL	883 L Sportster Low	06 - 13	<b>H.LS</b>
XL	883 L Super Low	11 - 13	<b>H.LS</b>
XL	883 N Iron	13 - 13	<b>H.LS</b>
XL	883 R Roadster	10 - 13	<b>H.LS</b>
XL	883 Sportster	04 - 13	<b>H.LS</b>
XL	883 Sportster R	05 - 13	<b>H.LS</b>
XL	1200 C Sportster		
	Custom	04 - 13	<b>H.LS</b>
XL	1200 L Sportster Low	07 - 10	<b>H.LS</b>
XL	1200 N Nightster	07 - 12	<b>H.LS</b>
XL	1200 R Sportster		
	Roadster	04 - 09	<b>H.LS</b>
XL	1200 V Seventy-Two	11 - 13	<b>H.LS</b>
XL	1200 X Forty-Eight	11 - 13	<b>H.LS</b>
XR	1200	08 - 10	<b>H.LS</b>
XR	1200 X	10 - 13	<b>H.LS</b>

Brake Pad 1:1 Drawings, Compounds, Fitments

STREET  
AMERICAN  
SCOOTER

HF • HS • LS  
H.HF • H.CT • H.HS • H.LS  
HF • CT • MS

RACING  
OFF ROAD  
ATV

RST • DC • DCC • DS-1 • DS-2 • RQ  
SI • RSI • CS  
ATS • SI • RSI • PSI

Drawings 1:1

Available compounds

H.HF • H.CT • H.HS

SBS 807

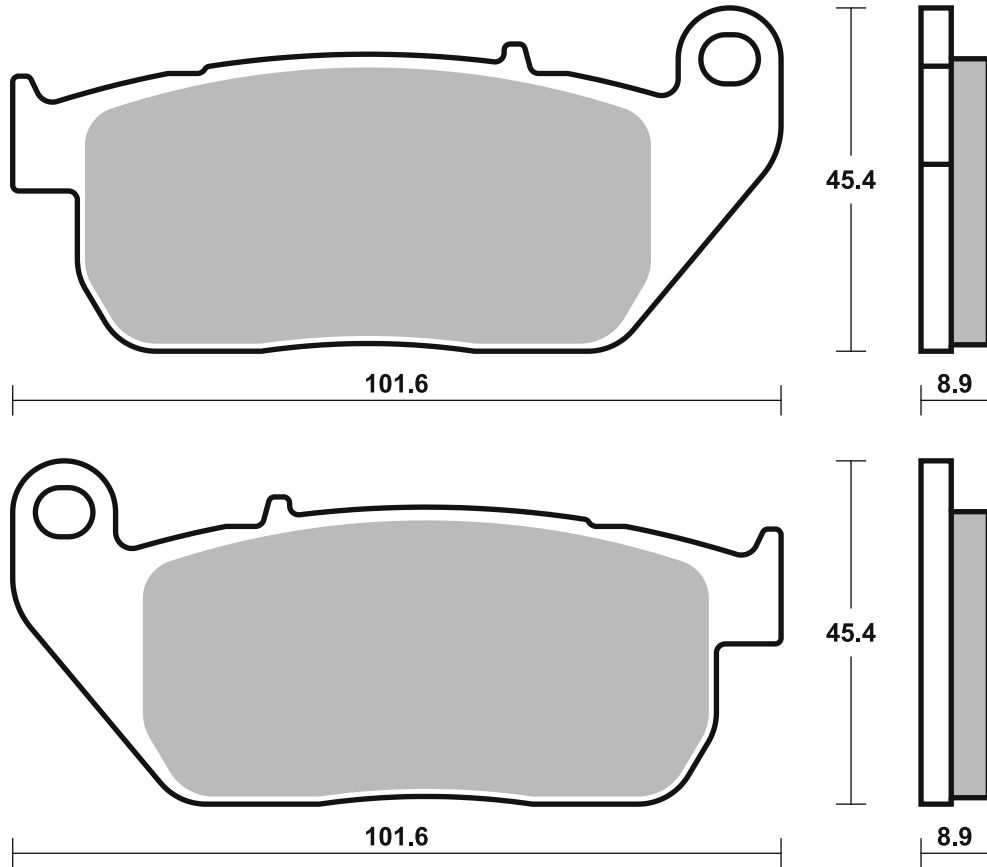

Available compounds

H.HF • H.CT • H.LS

SBS 808

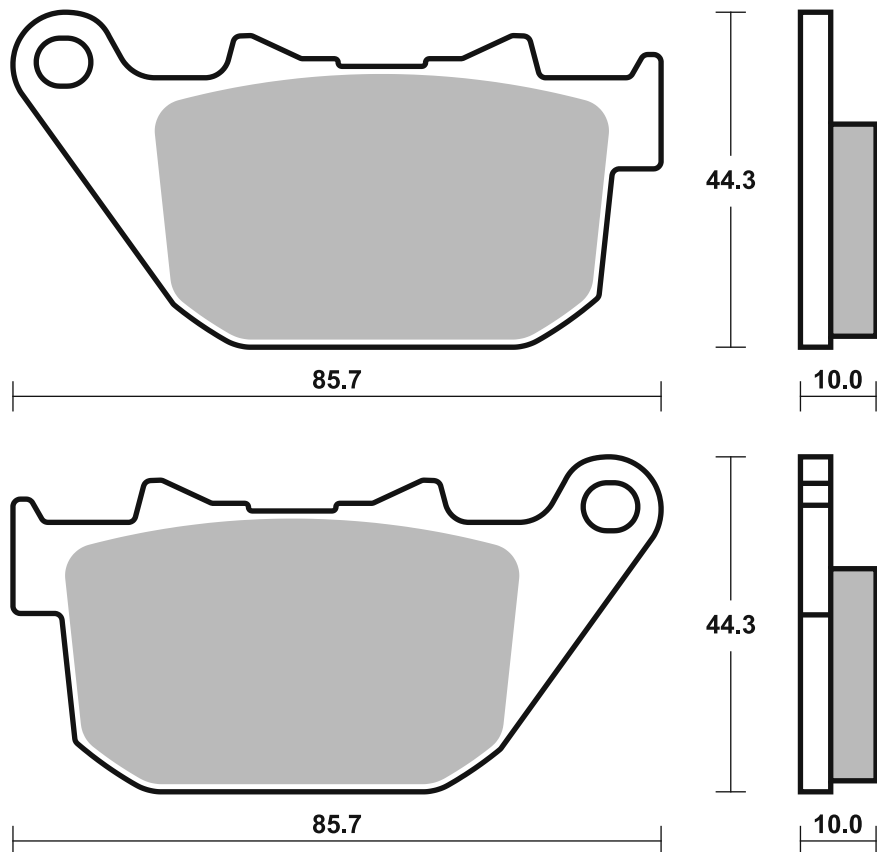

Dimensions in mm / Dimensions en mm  
1" = 25.4 mm, 1 mm = 0.04"

Brake Pad 1:1 Drawings,  
Compounds, Fitments

# Applications

## SBS 809 Recommended compound



<b>HEL</b>			
4 Piston Billet Caliper			
<b>HONDA</b>			
CBR	600 RR	05 - 17	<b>HS</b>
CBR	600 RR ABS	09 - 18	<b>HS</b>
VFR	800 F	14 - 16	<b>HS</b>
VFR	800 X Crossrunner	15 - 16	<b>HS</b>
CB	1000 R	08 - 16	<b>HS</b>
CBR	1000 RR Fireblade	04 - 16	<b>HS</b>

## SBS 810 Recommended compound



<b>ADLY</b>			
	300 Cross X Over	07 - 11	<b>SI</b>
	300 Cross X Road	07 - 11	<b>SI</b>
ATV	300 Sport	07 - 13	<b>SI</b>
	320 S	07 - 13	<b>SI</b>
	320 U	07 - 13	<b>SI</b>
<b>ARCTIC CAT</b>			
	250 DVX	06 - 09	<b>SI</b>
	300 DVX	09 - 16	<b>SI</b>
<b>CAN-AM</b>			
DS	250	08 - 18	<b>SI SI</b>
<b>CECTEK</b>			
	500 EFI Gladiator	09 - 13	<b>HF</b>
<b>CPI</b>			
	250 XS ATV	07 - 08	<b>SI</b>
<b>HERCULES</b>			
	280 ATV	07 - 07	<b>SI</b>
	300 ATV Sport	07 - 07	<b>SI</b>
<b>KAWASAKI</b>			
KVF	300 Brute Force	13 - 23	<b>SI SI</b>
<b>KYMCO</b>			
	250 MXU	06 - 14	<b>SI</b>
	250 Urban Quad	06 - 06	<b>SI</b>
KXR	250	04 - 14	<b>SI</b>
	300 Maxxer	06 - 13	<b>SI</b>



<b>KYMCO</b>			
	300 Maxxer Supermoto	15 - 15	<b>SI</b>
	300 MXU	06 - 17	<b>SI SI</b>
	500 MXU	06 - 08	<b>SI SI</b>
	500 UXV 4x4	08 - 14	<b>SI SI</b>
	550 MXU	12 - 20	<b>SI</b>
	700 MXU	13 - 20	<b>SI</b>
<b>PGO</b>			
	500 Bug	08 - 14	<b>HF</b>
BR	500 i Racer	07 - 08	<b>HF</b>
<b>SYM</b>			
SB	125 Wolf Ni	11 - 13	<b>HF</b>
	200 Quadlander	12 - 13	<b>SI</b>
	200 Trackrunner	05 - 08	<b>SI</b>
	250 Quadlander	06 - 07	<b>SI</b>
SN	250 Ni Wolf	14 - 15	<b>HF</b>
	300 City Max	06 - 07	<b>SI</b>
	300 Quadlander	06 - 13	<b>SI SI</b>
	300 Wolf Cafe Racer	15 - 15	<b>HF</b>
	300 Wolf Classic	15 - 15	<b>HF</b>
SB	300 Cafe Racer	16 - 17	<b>HF</b>
	600 Quad Raider	08 - 15	<b>SI SI</b>
<b>YAMAHA</b>			
MT	125	14 - 19	<b>HF</b>
YZF	125 R	08 - 18	<b>HF</b>



STREET  
AMERICAN  
SCOOTER

HF • HS • LS  
H.HF • H.CT • H.HS • H.LS  
HF • CT • MS

RACING  
OFF ROAD  
ATV

RST • DC • DCC • DS-1 • DS-2 • RQ  
SI • RSI • CS  
ATS • SI • RSI • PSI

Drawings 1:1

Available compounds

HS • DC • RST • DS-1 • DS-2

SBS 809

HS - Th. 8.0

RST / DC / DS-1 / DS-2 - Th. 9.0

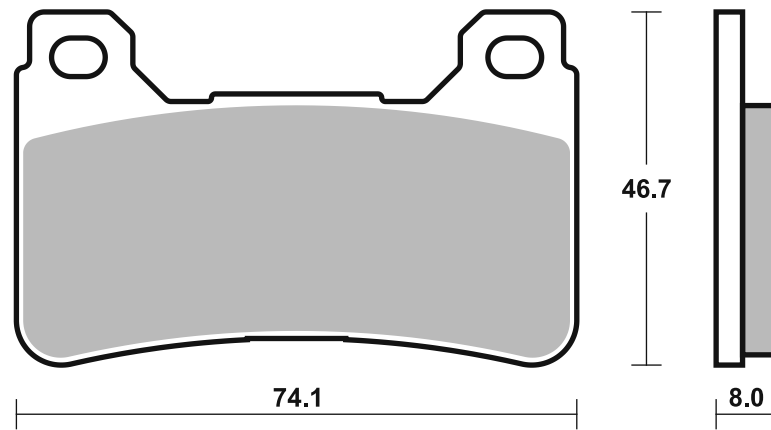

Available compounds

HF • RQ • CS • SI • RSI

SBS 810

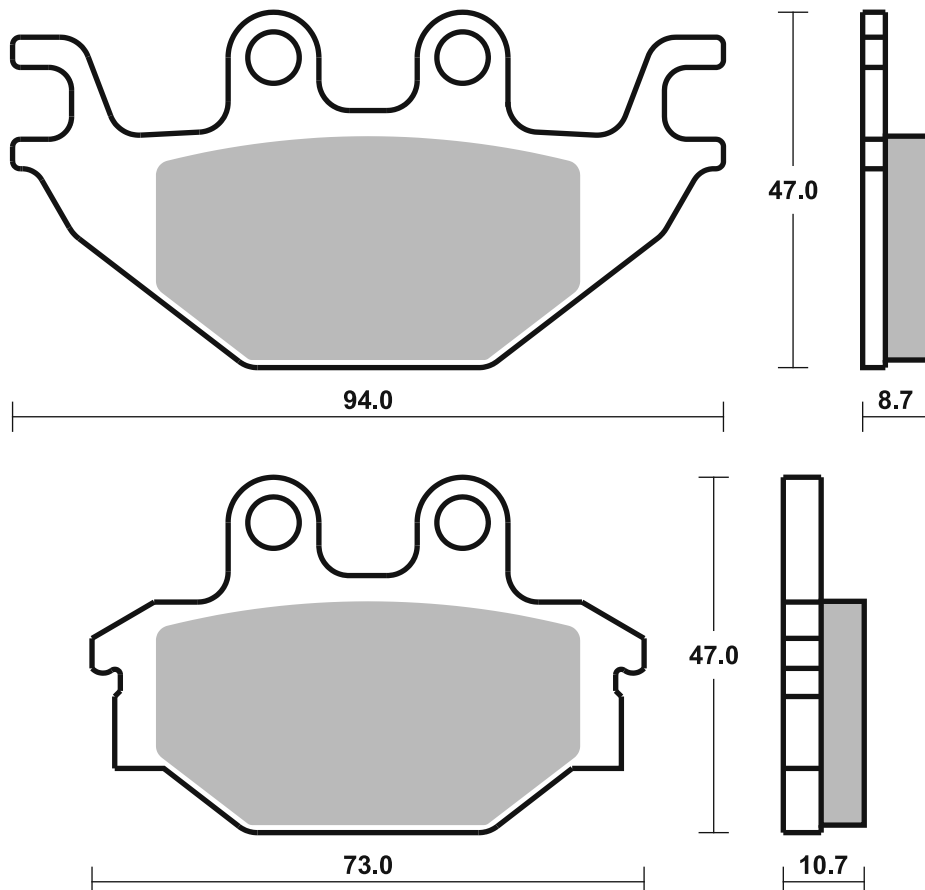

Dimensions in mm / Dimensions en mm  
1" = 25.4 mm, 1 mm = 0.04"

Brake Pad 1:1 Drawings,  
Compounds, Fitments

## Applications

### SBS 813

#### Recommended compound



#### HONDA

TRX	420 FA / FPA	09 - 13	<b>SI</b>
TRX	450 R	04 - 09	<b>SI</b>
TRX	650 FA Rincon	03 - 05	<b>SI</b>
TRX	650 FGA Rincon	04 - 05	<b>SI</b>
TRX	680 FA6 Rincon	06 - 15	<b>SI</b>
TRX	680 FGA6 Rincon	06 - 15	<b>SI</b>

### SBS 814

#### Recommended compound



#### BETA

R	150	10 - 13	<b>HF</b>
---	-----	---------	-----------

#### BRITXON

	125 Haycroft	15 - 18	<b>HF</b>
	125 Rayburn	15 - 23	<b>HF</b>
BX	125 Cromwell	15 - 23	<b>HF</b>
BX	125 Cromwell ABS	19 - 23	<b>HF</b>
BX	125 R Sunray	15 - 23	<b>HF</b>
BX	125 R Sunray ABS	19 - 23	<b>HF</b>
BX	125 S	15 - 23	<b>HF</b>
BX	125 X Felsberg	15 - 23	<b>HF</b>
BX	125 XC Felsberg	15 - 18	<b>HF</b>
BX	150 Cromwell	15 - 23	<b>HF</b>
BX	150 R Sunray	15 - 23	<b>HF</b>
BX	150 S	15 - 23	<b>HF</b>
BX	150 X Felsberg	15 - 23	<b>HF</b>
	1200 Cromwell	15 - 23	<b>LS</b>

#### HYOSUNG

GT	125	07 - 10	<b>HF</b>	<b>HF</b>
----	-----	---------	-----------	-----------



#### HYOSUNG

GT	125 Comet	04 - 06	<b>HF</b>	<b>HF</b>
GT	125 Naked	13 - 13	<b>HF</b>	<b>HF</b>
GT	125 R Supersport	07 - 16	<b>HF</b>	<b>HF</b>
GV	125 Aguila	05 - 11	<b>HF</b>	
RT	125 Karion	07 - 09	<b>HF</b>	<b>HF</b>
RX	125 SM	07 - 11	<b>HF</b>	<b>HF</b>
XRX	125	07 - 09	<b>HF</b>	<b>HF</b>
GT	250 Comet	03 - 08	<b>HF</b>	<b>HF</b>
GT	250 iR	13 - 14	<b>HS</b>	<b>LS</b>
GT	250 P	13 - 13	<b>HF</b>	<b>HF</b>
GT	250 R	07 - 12	<b>HF</b>	<b>HF</b>
GT	650	04 - 12	<b>HS</b>	<b>LS</b>
GT	650 i	13 - 13	<b>LS</b>	
GT	650 i Naked	15 - 15	<b>LS</b>	
GT	650 iR	13 - 14	<b>LS</b>	
GT	650 P	16 - 16	<b>HS</b>	<b>LS</b>
GT	650 R	05 - 13	<b>HS</b>	<b>LS</b>
GT	650 S	05 - 13	<b>HS</b>	<b>LS</b>
GT	650 TTC	07 - 11	<b>HS</b>	<b>LS</b>

#### HYOSUNG

GT	650 TTC / Custom			
	Trendkiller	07 - 11	<b>HS</b>	<b>LS</b>
GT	650 X	07 - 11	<b>HS</b>	<b>LS</b>
GV	650 Aguila	06 - 11	<b>HS</b>	<b>LS</b>
ST	700	11 - 13		<b>LS</b>
ST	700 i Deluxe	13 - 13		<b>LS</b>

#### ITALJET

	650 Bazooka	06 - 06	<b>HS</b>	<b>LS</b>
	650 Grifon	06 - 07	<b>HS</b>	<b>LS</b>

#### MASH

	125 Cafe Racer	14 - 16	<b>HF</b>	
	125 Seventy Five	14 - 17	<b>HF</b>	
	250 Cafe Racer	14 - 16	<b>HF</b>	
	250 Two Fifty	14 - 17	<b>HF</b>	

#### MEGELLI

	125 M, R, S	08 - 10	<b>HF</b>	
--	-------------	---------	-----------	--

### SBS 815

#### Recommended compound



#### GASGAS

EC	50 Boy	01 - 04	<b>HF</b>	<b>HF</b>
TXT	50 Boy	01 - 01	<b>HF</b>	<b>HF</b>
TXT	50 Rookie	02 - 03	<b>HF</b>	<b>HF</b>
MC	65	05 - 06	<b>HF</b>	<b>HF</b>
TXT	80 Rookie	02 - 03	<b>HF</b>	<b>HF</b>
	125 Pampera	04 - 13	<b>HF</b>	
	250 Pampera	02 - 13	<b>HF</b>	
	280 Pampera	04 - 08	<b>HF</b>	

Brake Pad 1:1 Drawings, Compounds, Fitments

STREET  
AMERICAN  
SCOOTER

HF • HS • LS  
H.HF • H.CT • H.HS • H.LS  
HF • CT • MS

RACING  
OFF ROAD  
ATV

RST • DC • DCC • DS-1 • DS-2 • RQ  
SI • RSI • CS  
ATS • SI • RSI • PSI

Drawings 1:1

Available compounds

SI • RSI

SBS 813

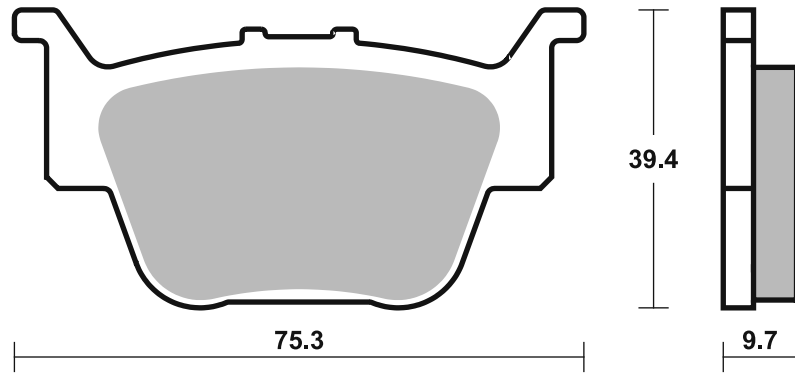

Available compounds

HF • HS • LS

SBS 814

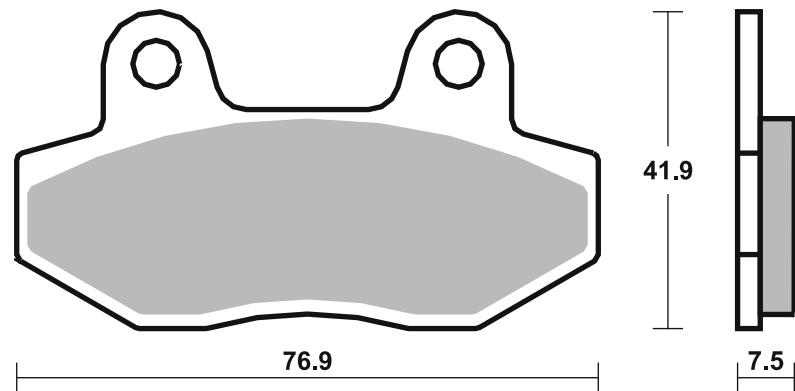

Available compounds

HF

SBS 815

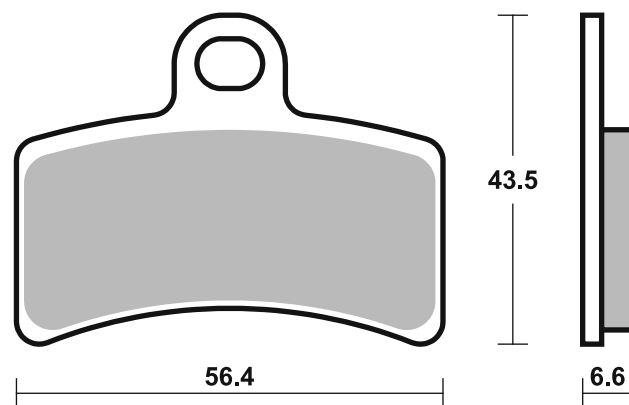

**SBS 816**

**Recommended compound**



**YAMAHA**

YXR	450 Rhino	06 - 09	<b>SI</b>
	660 Rhino	05 - 08	<b>SI</b>
YFM	700 R Raptor	06 - 08	<b>SI</b>
YFM	700 Raptor	09 - 12	<b>SI</b>

**SBS 817**

**Recommended compound**



**AJP**

PR4	125 Enduro	04 - 12	<b>HF</b>
PR4	125 Supermotard	04 - 09	<b>HF</b>
PR4	200 Enduro	04 - 04	<b>HF</b>
PR4	200 Supermotard	04 - 04	<b>HF</b>

**SHERCO**

	125	02 - 02	<b>HF</b>
	125 City Corp 4T		
	Enduro	03 - 07	<b>HF</b>
	125 City Corp 4T SM	03 - 07	<b>HF</b>

**TOMOS**

MC	125 T	06 - 08	<b>HF</b>
SE	125	05 - 08	<b>HF</b>

Brake Pad 1:1 Drawings, Compounds, Fittings

STREET  
AMERICAN  
SCOOTER

HF • HS • LS  
H.HF • H.CT • H.HS • H.LS  
HF • CT • MS

RACING  
OFF ROAD  
ATV

RST • DC • DCC • DS-1 • DS-2 • RQ  
SI • RSI • CS  
ATS • SI • RSI • PSI

Available compounds

SI • RSI

SBS 816

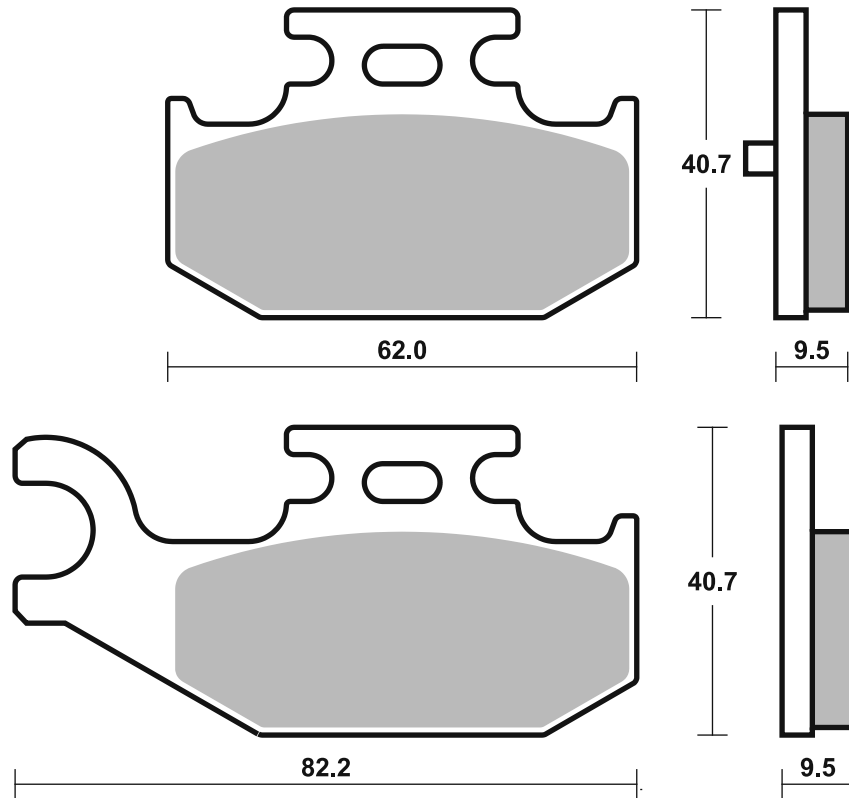

Available compounds

HF

SBS 817

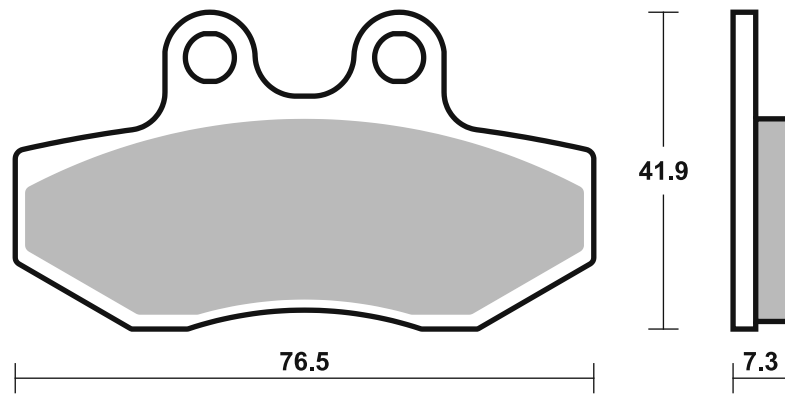

**SUZUKI**

RM	85	05 - 24	RSI

**APRILIA**

	125 Tuono ABS	17 - 19	HS
RS	125	17 - 19	HS
RS	125 GP	17 - 19	HS
RS-4	125 (AJP cal.)	11 - 19	HS
RS-4	125 Replica, ABS	16 - 19	HS

**BLATA**

	125 Enduro	07 - 08	HS
	125 Motard	07 - 08	HS

**DERBI**

GPR	80 Cup	04 - 05	HS
GPR	125	05 - 06	HS
GPR	125 Nude	05 - 08	HS
GPR	125 Racing	09 - 09	HS

**MALAGUTI**

NKD	50 Dragon	06 - 09	HS
-----	-----------	---------	----

**MOTORHISPANIA**

MH7	125 Naked	08 - 14	HS
RX	125 R	08 - 14	HS

**RIEJU**

	125 Tango	06 - 07	HS
RS3	125	10 - 13	HS

**TOMOS**

SM	125 F	06 - 08	HS
----	-------	---------	----

STREET  
AMERICAN  
SCOOTER

HF • HS • LS  
H.HF • H.CT • H.HS • H.LS  
HF • CT • MS

RACING  
OFF ROAD  
ATV

RST • DC • DCC • DS-1 • DS-2 • RQ  
SI • RSI • CS  
ATS • SI • RSI • PSI

Drawings 1:1

Available compounds

CS • SI • RSI

SBS 820

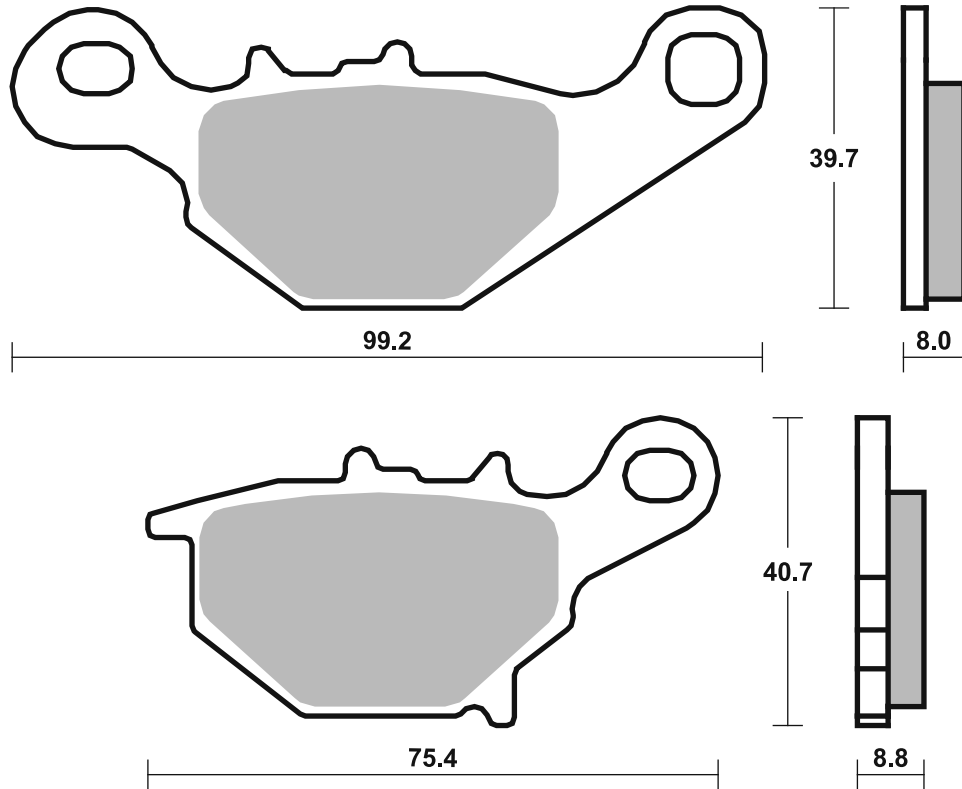

Available compounds

HF • HS

SBS 821

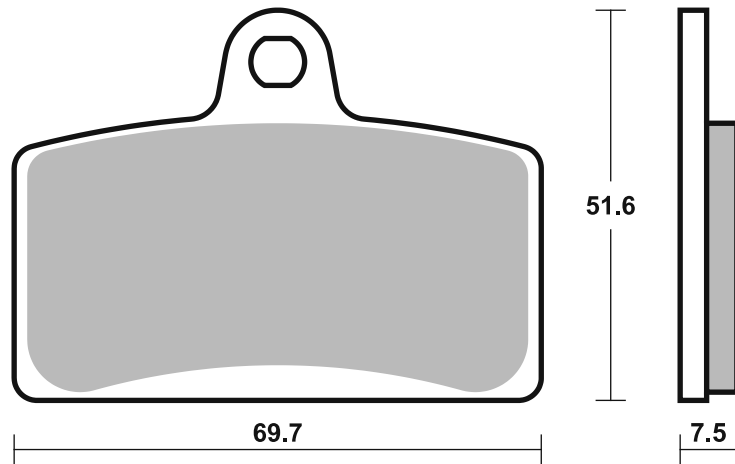

**SBS 822 Recommended compound**



ARCTIC CAT			
	250 2x4	05 - 06	ATS ATS
	300 2x4	10 - 13	ATS ATS
	300 4x4	05 - 05	ATS ATS
	400 2x4/4x4 (FIS)	05 - 07	ATS ATS
TRV	400	09 - 13	ATS ATS
	450 H1	10 - 10	ATS ATS
XC	450	11 - 14	ATS ATS
	500 2x4/4x4 (FIS)	05 - 09	ATS ATS
	500 TBX 4x4	05 - 06	ATS ATS
	500 TRV 4x4	05 - 06	ATS ATS
	550 H1	09 - 13	ATS ATS
	550 LTD	09 - 12	ATS ATS
	550 Prowler	09 - 14	ATS ATS
TRV	550	09 - 14	ATS ATS
	650 H1 4x4 Aut.	05 - 11	ATS ATS
	650 Prowler	06 - 08	ATS ATS
	650 V2 4x4 Aut.	05 - 06	ATS ATS
	650 V2 4x4 Aut. LE	05 - 06	ATS ATS



ARCTIC CAT			
	700 Diesel	06 - 14	ATS ATS
	700 H1	09 - 10	ATS ATS
	700 Prowler	08 - 08	ATS ATS
	700 Wildcat Sport	15 - 18	ATS
	700 Wildcat Sport LTD.	16 - 18	ATS
	700 Wildcat Sport LTD.	17 - 18	ATS
	700 Wildcat Sport SE	17 - 19	ATS
	700 Wildcat Sport XT	15 - 18	ATS
	700 Wildcat Sport XT	16 - 18	ATS
	700 Wildcat Sport XT	16 - 18	ATS
TRV	700	09 - 12	ATS ATS
	1000 Prowler	09 - 09	ATS ATS
	1000 Thundercat	09 - 14	ATS ATS
	1000 Wildcat 4X	16 - 18	ATS
	1000 Wildcat X	16 - 18	ATS



ARCTIC CAT			
	1000 Wildcat X Ltd.	17 - 18	ATS
	1000 Wildcat X SE	17 - 18	ATS
TRV	1000	09 - 14	ATS ATS

KYMCO			
	400 Maxxer	08 - 10	ATS ATS
	400 MXU	08 - 11	ATS ATS
	450 i Maxxer	10 - 14	ATS ATS
	450 i MXU	11 - 14	ATS ATS

POLARIS			
	300 Hawkeye 2x4, 4x4	06 - 06	ATS ATS

**SBS 824 Recommended compound**



APRILIA			
RS	125	99 - 05	HF
RS	125 Extrema	93 - 98	HF
RS	125 Pista	05 - 07	HF

**SBS 825 Recommended compound**



NISSIN			
	4 Piston Racing Caliper (2)		

Brake Pad 1:1 Drawings, Compounds, Fitments



STREET  
AMERICAN  
SCOOTER

HF • HS • LS  
H.HF • H.CT • H.HS • H.LS  
HF • CT • MS

RACING  
OFF ROAD  
ATV

RST • DC • DCC • DS-1 • DS-2 • RQ  
SI • RSI • CS  
ATS • SI • RSI • PSI

Drawings 1:1

Available compounds

SI • RSI • ATS • PSI

SBS 822

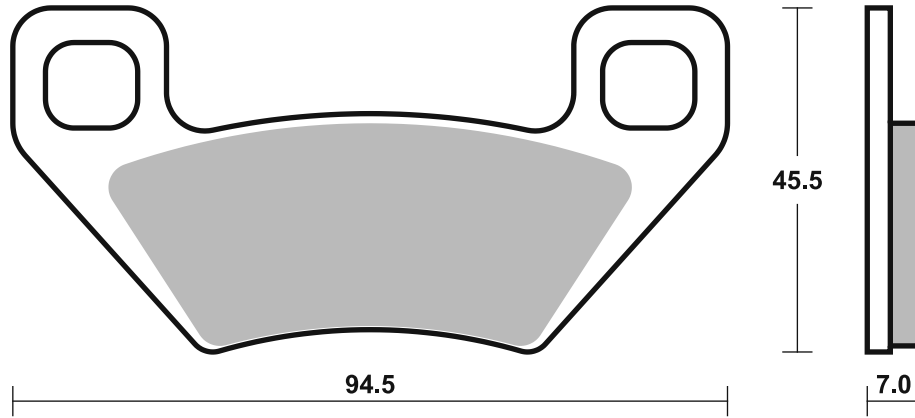

Available compounds

HF • RQ

SBS 824

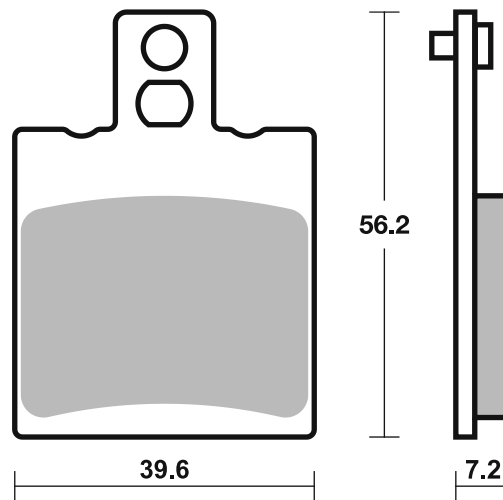

Available compounds

DC • DS-1 • DS-2

SBS 825

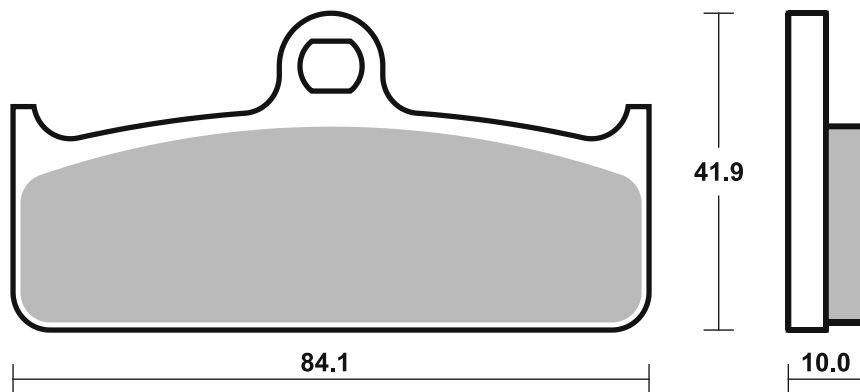



HARLEY DAVIDSON				
XL	883 R Sportster	00 - 03	H.HS	H.LS
XL	883 Sportster Custom	00 - 03	H.HS	H.LS
XLH	883 Sportster	00 - 03	H.HS	H.LS
XLH	883 Sportster Hugger	00 - 03	H.HS	H.LS
VRSCA	1130 V-Rod	02 - 05	H.HS	H.LS
VRSCB	1130 V-Rod	04 - 04	H.HS	H.LS
XL	1200 Sportster Custom	00 - 03	H.HS	H.LS
XL	1200 Sportster Sport	00 - 03	H.HS	H.LS
XLH	1200 Sportster	00 - 03	H.HS	H.LS
FLHR/I	1450 Road King	00 - 06	H.HS	H.LS
FLHRCI	1450 Road King			
	Classic	00 - 06	H.HS	H.LS
FLHRS/I	1450 Road King			
	Custom	04 - 06	H.HS	H.LS
FLHT/I	1450 Electra Glide			
	Standard	00 - 06	H.HS	H.LS
FLHTC/I	1450 Electra Glide			
	Classic	00 - 06	H.HS	H.LS
FLHTCUI	1450 Ultra Classic			
	Electra Glide	00 - 06	H.HS	H.LS
FLHXI	1450 Street Glide	06 - 06	H.HS	H.LS
FLSTC	1450 Softail	06 - 07	H.HS	H.LS
FLSTC/I	1450 Heritage Softail			
	Classic	00 - 04	H.HS	H.LS
FLSTCI	1450 Softail	06 - 06	H.HS	H.LS
FLSTF	1450 Fat Boy	06 - 07	H.HS	H.LS
FLSTF/I	1450 Fat Boy	00 - 04	H.HS	H.LS
FLSTFI	1450 Fat Boy	06 - 06	H.HS	H.LS
FLSTI	1450 Heritage Softail	06 - 06	H.HS	
FLSTN/I	1450 Softail Deluxe	06 - 06	H.HS	H.LS
FLSTS/I	1450 Heritage Springer	00 - 03		H.LS
FLSTSC/I	1450 Springer Softail			
	Classic	06 - 06		H.LS
FLTR/I	1450 Road Glide			
	Classic	00 - 06	H.HS	H.LS
FXD	1450 Dyna Super Glide	00 - 03	H.HS	H.LS
FXDBI	1450 Dyna Street Bob	06 - 06	H.HS	H.LS
FXDC/I	1450 Dyna Super Glide			
	Custom	05 - 06	H.HS	H.LS
FXDI	1450 35th Anniversary			
	Super Glide	06 - 06	H.HS	
FXDI	1450 Dyna Super Glide	04 - 07	H.HS	H.LS
FXDL	1450 Dyna Low Rider	00 - 03	H.HS	H.LS
FXDLI	1450 Dyna Low Rider	04 - 06	H.HS	H.LS
FXDS	1450 Dyna Convertible	00 - 02	H.HS	H.LS
FXDWG	1450 Dyna Wide Glide	00 - 03	H.HS	H.LS
FXDWGI	1450 Dyna Wide Glide	04 - 06	H.HS	H.LS
FXDX	1450 Dyna Super			
	Glide Sport	00 - 03	H.HS	H.LS
FXDXI	1450 Dyna Super			
	Glide Sport	04 - 06	H.HS	H.LS
FXDXT	1450 Dyna Super			
	Glide T-Sport	00 - 03	H.HS	H.LS
FXST/I	1450 Softail Standard	00 - 06	H.HS	H.LS
FXST/I	1450 Softail Standard	06 - 06	H.HS	
FXSTB/I	1450 Night Train	00 - 06	H.HS	H.LS
FXSTB/I	1450 Night Train	06 - 06	H.HS	
FXSTD/I	1450 Softail Deuce	00 - 06	H.HS	H.LS
FXSTD/I	1450 Softail Deuce	06 - 06	H.HS	
FXSTS/I	1450 Softail	05 - 05		H.LS
FXSTS/I	1450 Springer Softail	00 - 04		H.LS
FLHR	1584 Road King	07 - 07	H.HS	H.LS
FLHRC	1584 Road King			
	Classic	07 - 07	H.HS	H.LS
FLHRS	1584 Road King			
	Custom	07 - 07	H.HS	H.LS
FLHT	1584 Electra Glide			
	Standard	07 - 07	H.HS	H.LS
FLHTC	1584 Electra Glide			
	Classic	07 - 07	H.HS	H.LS



HARLEY DAVIDSON				
FLHTCU	1584 Ultra Classic			
	Electra Glide	07 - 08	H.HS	H.LS
FLHX	1584 Street Glide	07 - 07	H.HS	H.LS
FLSTC	1584 Heritage Softail			
	Classic	07 - 07	H.HS	
FLSTF	1584 Fat Boy	07 - 07	H.HS	
FLSTN	1584 Softail Deluxe	07 - 07	H.HS	
FXD	1584 Dyna Super Glide	07 - 07	H.HS	H.LS
FXDB	1584 Dyna Street Bob	07 - 07	H.HS	H.LS
FXDC	1584 Dyna Super Glide			
	Custom	07 - 07	H.HS	H.LS
FXDL	1584 Dyna Low Rider	07 - 07	H.HS	H.LS
FXDWG	1584 Dyna Wide Glide	07 - 07	H.HS	H.LS
FXST	1584 Softail Standard	07 - 07	H.HS	
FXSTB	1584 Night Train	07 - 07	H.HS	
FXSTC	1584 Softail Custom	07 - 07	H.HS	
FXSTD	1584 Softail Deuce	07 - 07	H.HS	

STREET  
AMERICAN  
SCOOTER

HF • HS • LS  
H.HF • H.CT • H.HS • H.LS  
HF • CT • MS

RACING  
OFF ROAD  
ATV

RST • DC • DCC • DS-1 • DS-2 • RQ  
SI • RSI • CS  
ATS • SI • RSI • PSI

Drawings 1:1

Available compounds

H.HF • H.CT • H.HS • H.LS

SBS 826

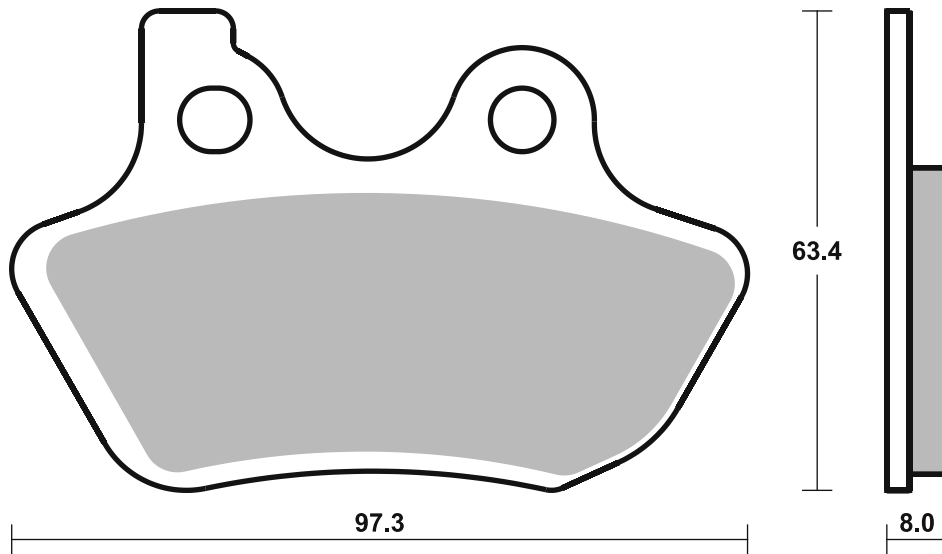
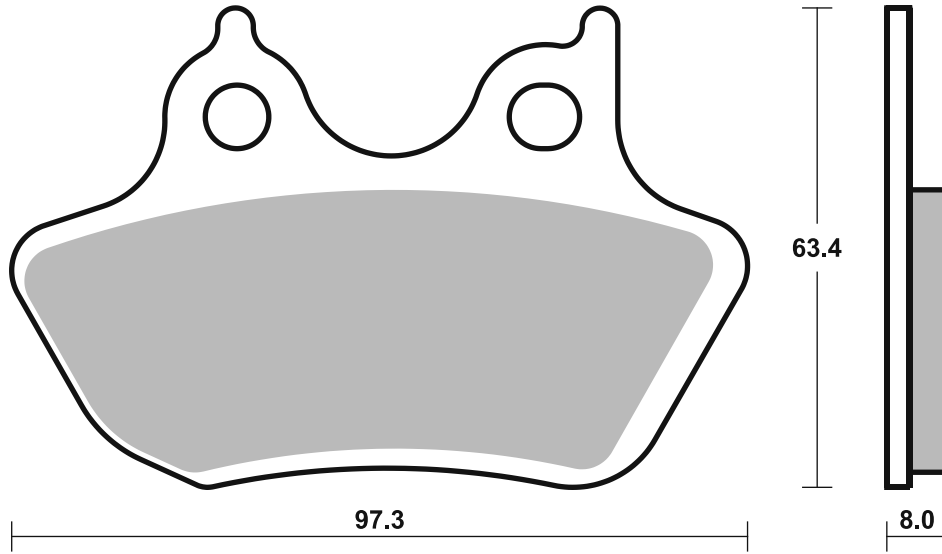



STREET  
AMERICAN  
SCOOTER

HF • HS • LS  
H.HF • H.CT • H.HS • H.LS  
HF • CT • MS

RACING  
OFF ROAD  
ATV

RST • DC • DCC • DS-1 • DS-2 • RQ  
SI • RSI • CS  
ATS • SI • RSI • PSI

Available compounds

ATS

SBS 827

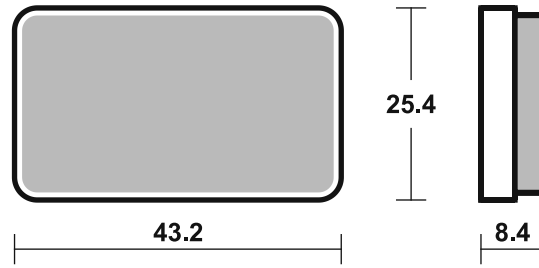

Available compounds

HF • HS • LS

SBS 828

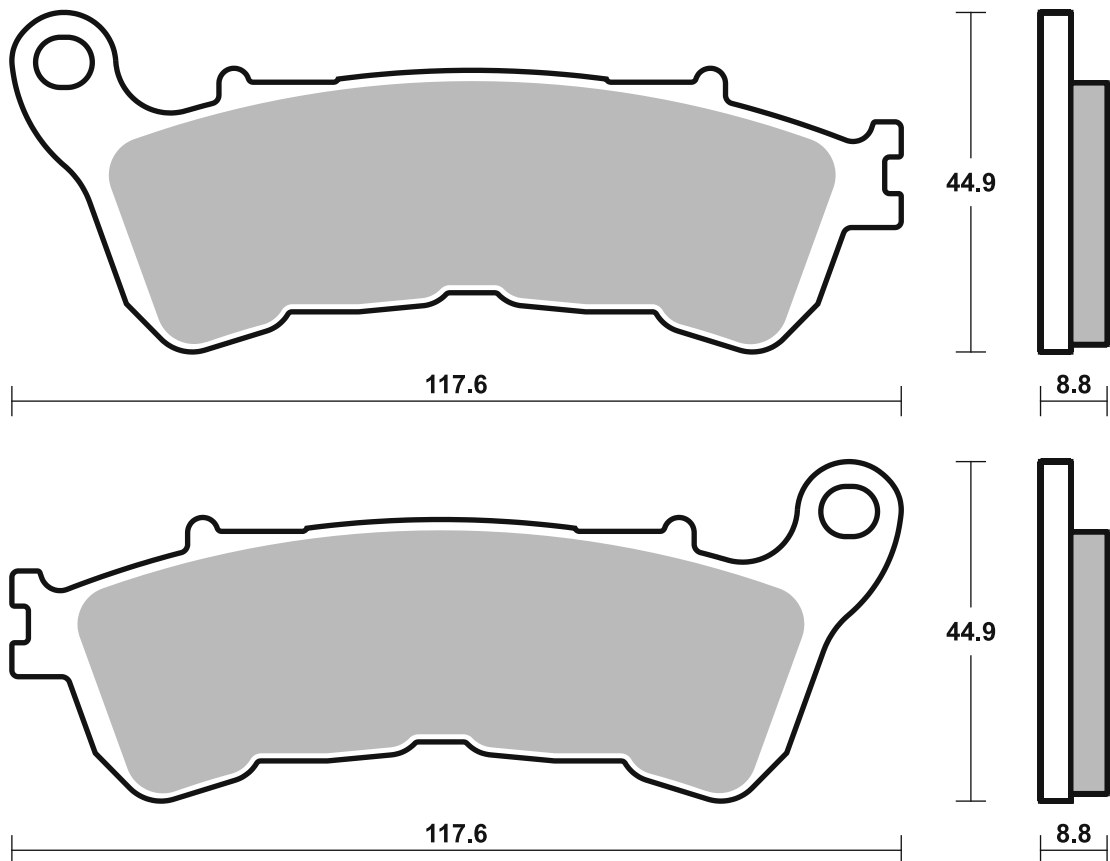



STREET  
AMERICAN  
SCOOTER

HF • HS • LS  
H.HF • H.CT • H.HS • H.LS  
HF • CT • MS

RACING  
OFF ROAD  
ATV

RST • DC • DCC • DS-1 • DS-2 • RQ  
SI • RSI • CS  
ATS • SI • RSI • PSI

Drawings 1:1

Available compounds

SI

SBS 829

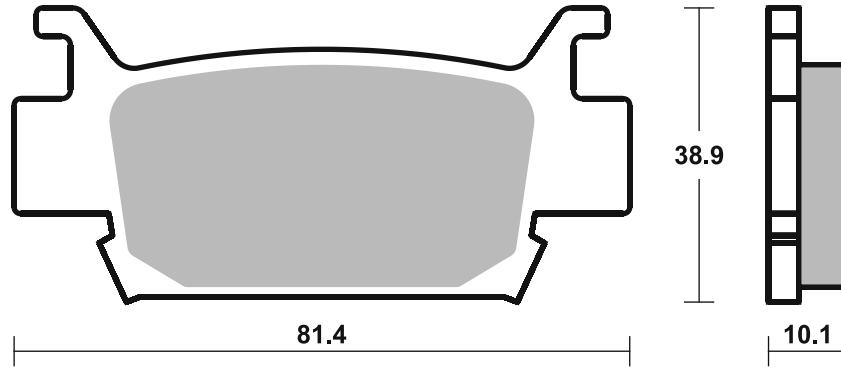

Available compounds

H.HF • H.CT • H.HS • H.LS

SBS 830

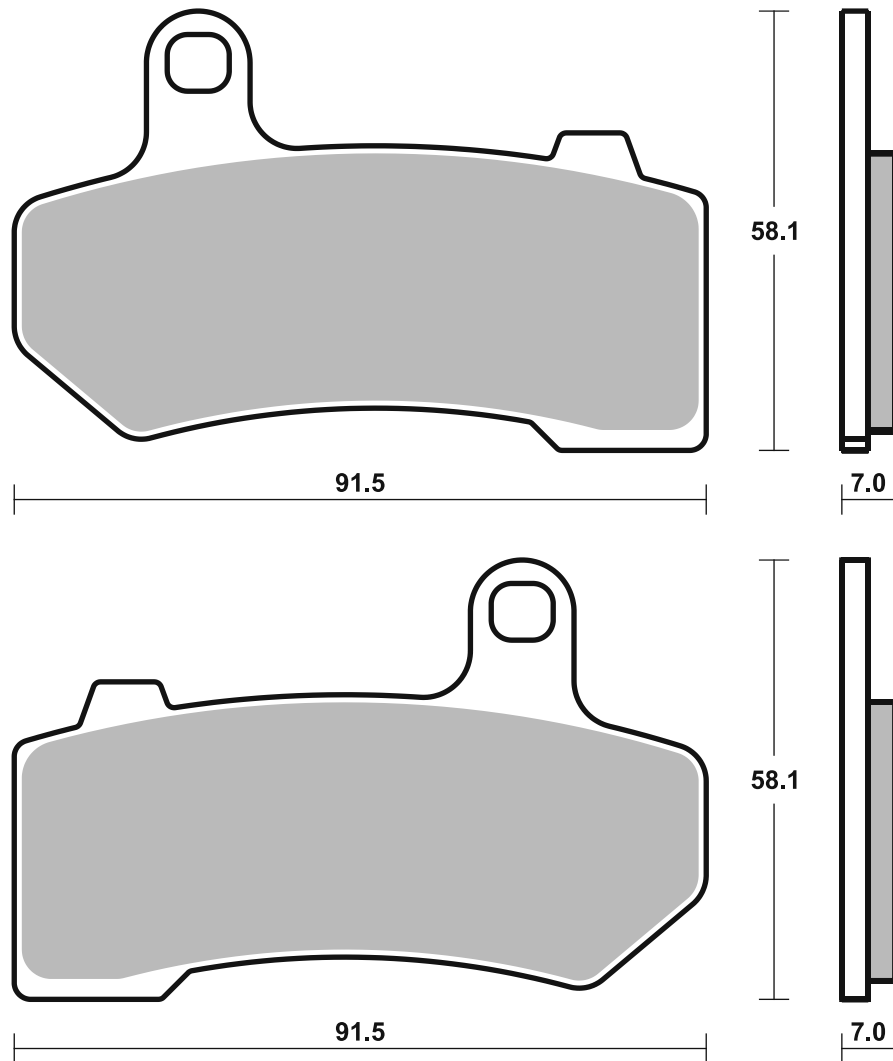





STREET  
AMERICAN  
SCOOTER

HF • HS • LS  
H.HF • H.CT • H.HS • H.LS  
HF • CT • MS

RACING  
OFF ROAD  
ATV

RST • DC • DCC • DS-1 • DS-2 • RQ  
SI • RSI • CS  
ATS • SI • RSI • PSI

Drawings 1:1

Available compounds

HF • LS

SBS 832

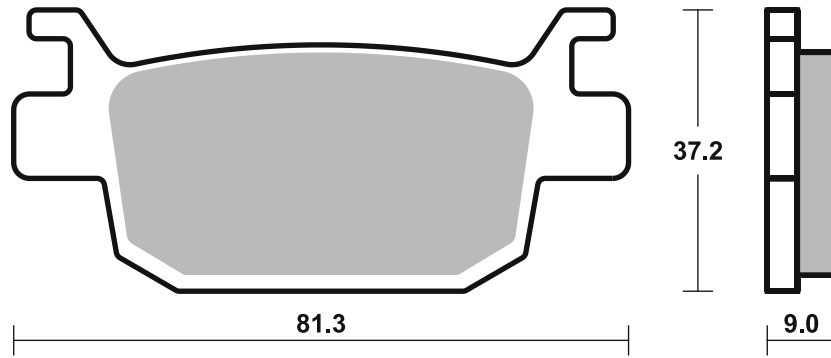

Available compounds

HF • LS • RQ

SBS 833

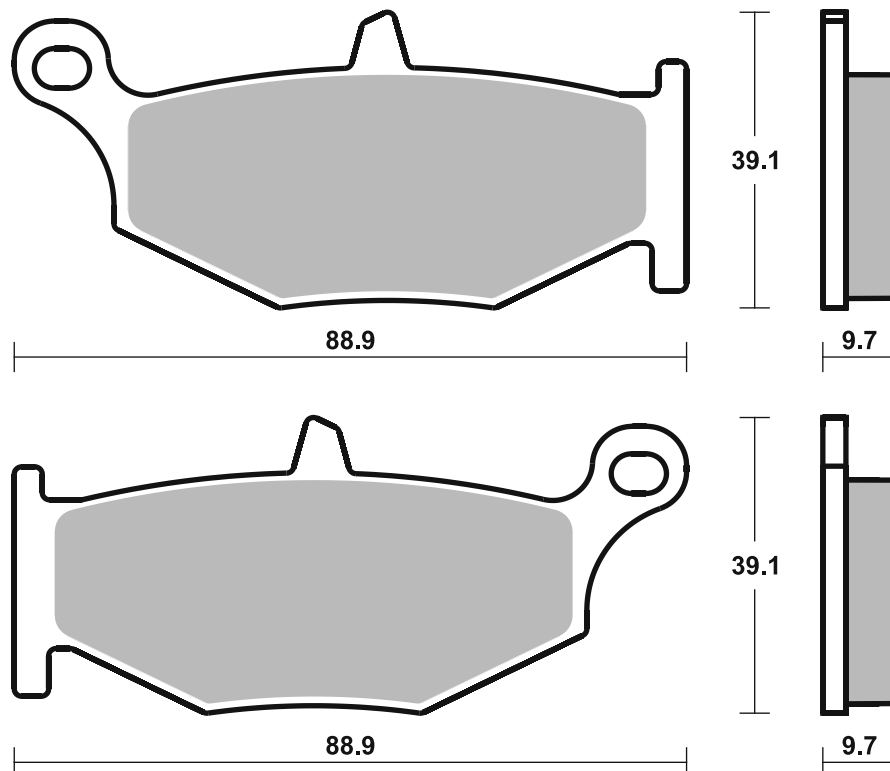

## Applications

### SBS 834

### Recommended compound



#### HONDA

CB	600 Hornet	07 - 12	LS
CBR	600 F	11 - 13	LS
CBR	600 RR	07 - 24	LS
CBR	600 RR ABS	09 - 18	LS
CBR	1000 RR Fireblade	06 - 22	LS
CBR	1000 RR SP	14 - 22	LS
CBR	1000 RR SP2	17 - 19	LS

#### KAWASAKI

ZX-6R	636 Ninja	13 - 18	LS
ZX-6R	636 Ninja ABS	13 - 24	LS
ZX-6R	636 Ninja Upgrade		
	DS	13 - 24	LS
ZX-10R	1000 Ninja	11 - 24	LS
ZX-10R	1000 Ninja SE	18 - 22	LS
ZX-10RR	1000 Ninja	17 - 24	LS

#### SUZUKI

GSX-R	600	11 - 24	LS
GSX-R	750	11 - 23	LS
GSX-R	1000	09 - 24	LS
GSX-R	1000 R	17 - 24	LS

#### YAMAHA

YZF	600 R6	17 - 24	LS
YZF	600 R6		
	Quick change /		
	Front wheel	17 - 24	LS
YZF	1000 R1	15 - 24	LS
YZF	1000 R1M	15 - 24	LS
YZF	1000 R1S	16 - 16	LS

### SBS 835

### Recommended compound



#### SUZUKI

KLT-A	400 King Quad	08 - 14	SI
KLT-F	400 King Quad	08 - 14	SI
LT-A	400 King Quad	08 - 14	SI
LT-F	400 King Quad	08 - 14	SI
LT-A	450 King Quad	08 - 14	SI
LT-A	500 King Quad	11 - 14	SI
LT-A	700 King Quad	05 - 11	SI
LT-A	750 King Quad	08 - 14	SI

STREET  
AMERICAN  
SCOOTER

HF • HS • LS  
H.HF • H.CT • H.HS • H.LS  
HF • CT • MS

RACING  
OFF ROAD  
ATV

RST • DC • DCC • DS-1 • DS-2 • RQ  
SI • RSI • CS  
ATS • SI • RSI • PSI

Drawings 1:1

Available compounds

HF • LS • RQ

SBS 834

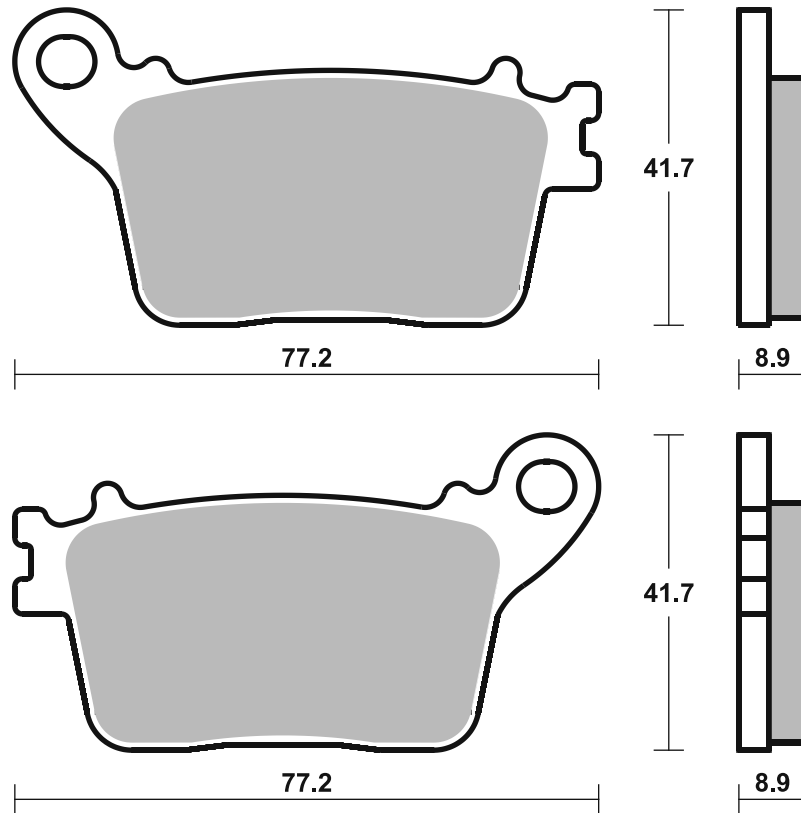

Available compounds

SI • RSI

SBS 835

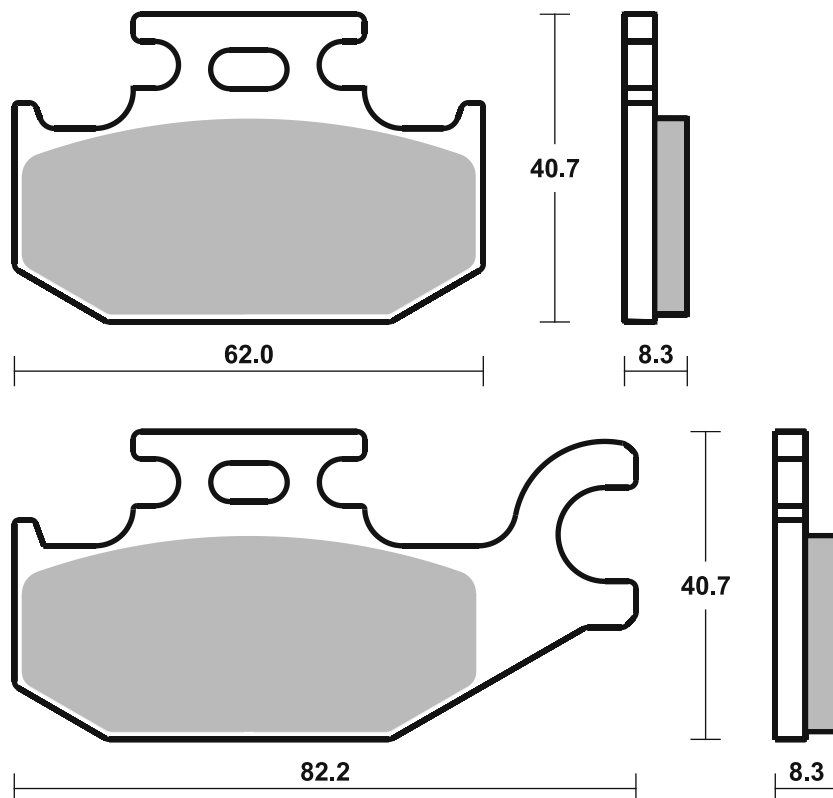

# Applications

## SBS 836

### Recommended compound



<b>SUZUKI</b>			
KLT-A	400 King Quad	08 - 14	SI
KLT-F	400 King Quad	08 - 14	SI
LT-A	400 King Quad	08 - 14	SI
LT-F	400 King Quad	08 - 14	SI
LT-A	450 King Quad	08 - 14	SI
LT-A	500 King Quad	11 - 14	SI
LT-A	700 King Quad	05 - 11	SI
LT-A	750 King Quad	08 - 14	SI

## SBS 838

### Recommended compound



<b>KAWASAKI</b>			
ZX-6R	600 Ninja	07 - 17	HS
Z	750 R	11 - 12	HS
Z	1000	07 - 09	HS
GTR	1400	07 - 16	HS
GTR	1400 ABS	07 - 16	HS
ZZR	1400	06 - 19	HS
ZZR	1400 ABS	06 - 19	HS
<b>SUZUKI</b>			
	1300 B-King	07 - 07	HS

Brake Pad 1:1 Drawings,  
Compounds, Fitments

STREET  
AMERICAN  
SCOOTER

HF • HS • LS  
H.HF • H.CT • H.HS • H.LS  
HF • CT • MS

RACING  
OFF ROAD  
ATV

RST • DC • DCC • DS-1 • DS-2 • RQ  
SI • RSI • CS  
ATS • SI • RSI • PSI

Drawings 1:1

Available compounds

SI • RSI

SBS 836

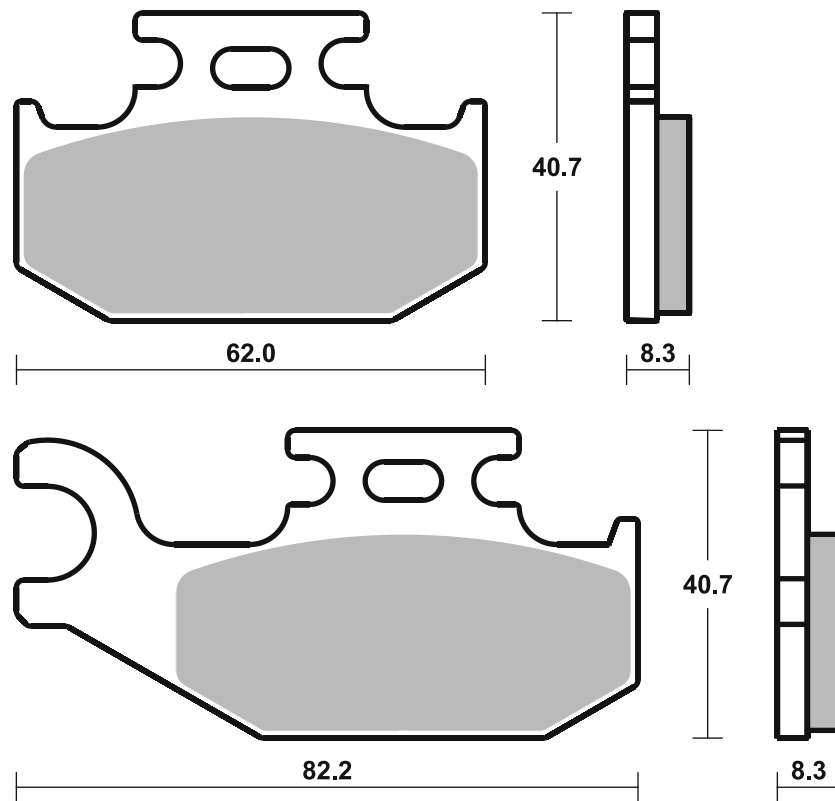

Available compounds

HS • DC • RST • DS-1 • DS-2

SBS 838

1 set = 4 pcs.

HS - Th. 7.8

RST / DC / DS-1 / DS-2 - Th. 9.0

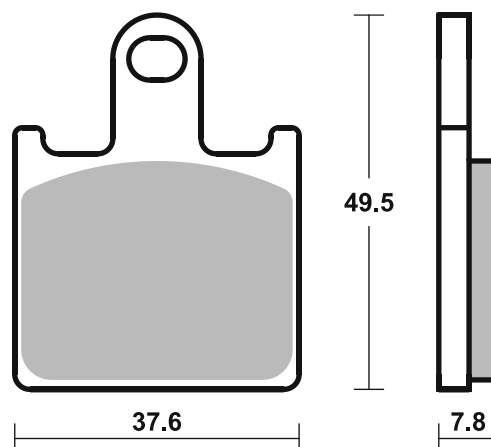

# Applications

## SBS 839

## Recommended compound



### YAMAHA

YZF	1000 R1 (4-pad)	07 - 14	HS
YZF	1000 R1 (4-pad) ABS	12 - 14	HS
MT-01	1700	07 - 16	HS
VMX	1700 V-Max	09 - 18	HS

## SBS 840

## Recommended compound



### FANTIC

XE	125	22 - 22	SI
XX	125	20 - 21	RSI
XEF	250	22 - 22	SI
XEF	450 Rally	22 - 22	SI

### YAMAHA

YZ	125	08 - 21	RSI
WR	250 F Efi	18 - 21	SI
WR	250 F Enduro GP	18 - 18	SI
YZ	250	08 - 21	RSI
YZ	250 F	07 - 20	RSI
YZ	250 FX	15 - 21	SI
WR	450 F	16 - 20	SI
YZ	450 F	08 - 19	RSI
YZ	450 FX	16 - 20	SI

STREET  
AMERICAN  
SCOOTER

HF • HS • LS  
H.HF • H.CT • H.HS • H.LS  
HF • CT • MS

RACING  
OFF ROAD  
ATV

RST • DC • DCC • DS-1 • DS-2 • RQ  
SI • RSI • CS  
ATS • SI • RSI • PSI

Drawings 1:1

Available compounds

HS • DC • RST • DS-1

SBS 839

1 set = 2 pcs. small / large

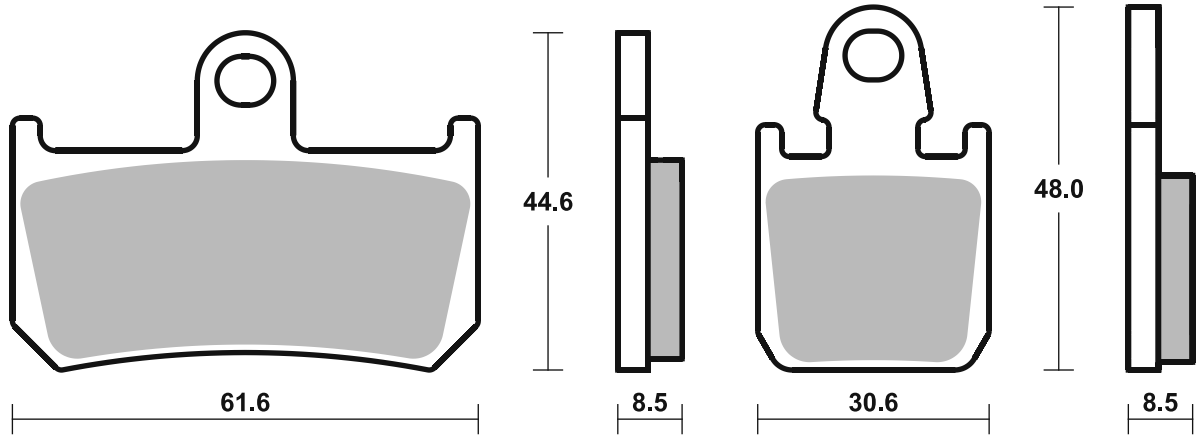

Available compounds

CS • SI • RSI

SBS 840

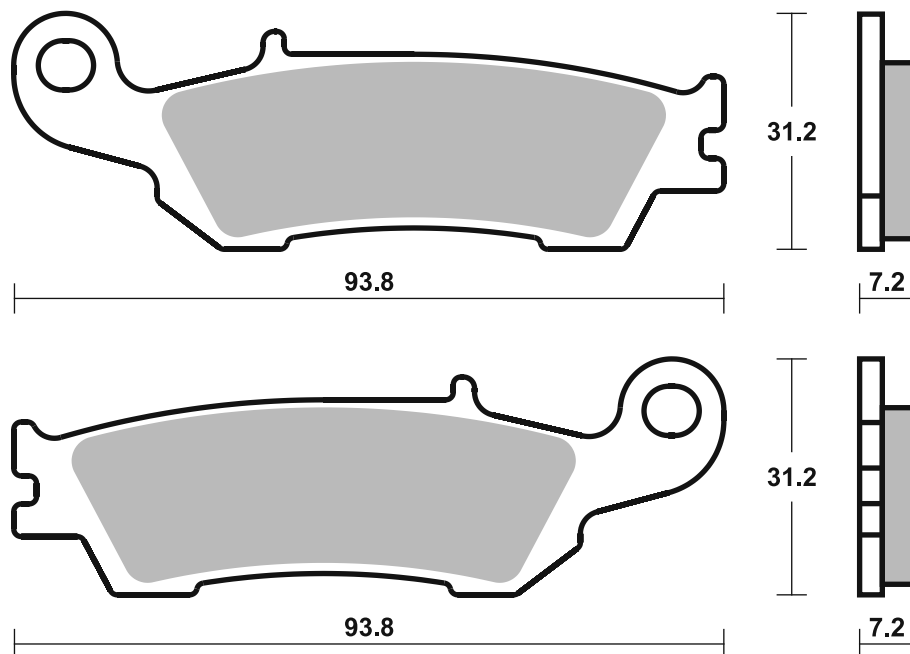



<b>APRILIA</b>			
RSV4	1000 ,ABS	09 - 13	<b>HS</b>
RSV4	1000 Factory	09 - 11	<b>HS</b>
RSV4	1000 Factory APRC		
	ABS	13 - 16	<b>HS</b>
RSV4-R	1000 ,ABS APRC	10 - 10	<b>HS</b>
RSV4	1100 Factory	19 - 23	<b>HS</b>

<b>BENELLI</b>			
TNT	1130 R	17 - 17	<b>HS</b>

<b>BIMOTA</b>			
3D	800 Tesi	16 - 16	<b>HS</b>
	1000 Tera	24 - 24	<b>HS</b>
	1000 Tesi H2	21 - 23	<b>HS</b>
KB4	1000	23 - 23	<b>HS</b>
KB4	1000 RC	23 - 23	<b>HS</b>
	1200 Impeto	16 - 17	<b>HS</b>

<b>BREMO RACING CALIPERS</b>			
100 mm Radial Caliper .484,			
220B47310, P4 32			
100 mm Radial GP4 RX			
220B01020 P4 32			
(disc min. Th. 4.5 mm)			
100 mm Radial Monoblock			
220988530, P4 34			
108 mm Radial Caliper .484,			
220B47310, P4 32			
108 mm Radial GP4 RX			
220B01020 P4 32			
(disc min. Th. 4.5 mm)			
108 mm Radial Monoblock			
220A39710, P4 34			
130 mm Radial GP4 RX			
220B01020 P4 32			
(disc min. Th. 4.5 mm)			
Radial GP4 RX 220B01010			

<b>CF MOTO</b>			
	700 CL-X Spirit	24 - 24	<b>HS</b>
	700 CL-X Sport	22 - 22	<b>HS</b>
	800 NK GP	24 - 24	<b>HS</b>

<b>DUCATI</b>			
	848 EVO	11 - 12	<b>HS</b>
	848 Streetfighter S	12 - 15	<b>HS</b>
D16RR	990 Desmosedici RR	07 - 08	<b>HS</b>
	998 Superleggera V4	20 - 24	<b>HS</b>
	1000 Panigale V4 R	19 - 24	<b>HS</b>
	1098	07 - 08	<b>HS</b>
	1098 R	08 - 10	<b>HS</b>
	1098 R Bayliss LE	09 - 10	<b>HS</b>
	1098 S	07 - 08	<b>HS</b>
	1098 Streetfighter	09 - 14	<b>HS</b>
	1098 Streetfighter S	09 - 13	<b>HS</b>
	1100 Hypermotard		
	EVO SP	10 - 12	<b>HS</b>
	1100 Hypermotard S	07 - 09	<b>HS</b>
	1103 Multistrada V4 RS	24 - 24	<b>HS</b>
	1103 Panigale V4	18 - 24	<b>HS</b>
	1103 Panigale V4 SP	21 - 21	<b>HS</b>
	1103 Panigale V4 SP2	22 - 24	<b>HS</b>
	1103 Panigale V4		
	Speciale	18 - 19	<b>HS</b>
	1103 Panigale V4S	18 - 24	<b>HS</b>
	1103 Panigale V4S		
	Corse	19 - 19	<b>HS</b>
	1103 Streetfighter V4	20 - 24	<b>HS</b>
	1103 Streetfighter V4		
	Lamborghini	20 - 24	<b>HS</b>



<b>DUCATI</b>			
	1103 Streetfighter V4 SP	22 - 23	<b>HS</b>
	1103 Streetfighter V4		
	SP2	23 - 24	<b>HS</b>
	1103 Streetfighter V4S	20 - 24	<b>HS</b>
	1158 Diavel V4	23 - 24	<b>HS</b>
	1158 Multistrada V4		
	Pikes Peak	22 - 24	<b>HS</b>
	1158 Multistrada V4		
	Rally	23 - 24	<b>HS</b>
	1158 Multistrada V4S	21 - 24	<b>HS</b>
	1158 Multistrada V4S		
	Sport	21 - 24	<b>HS</b>
	1198	09 - 13	<b>HS</b>
	1198 S	09 - 12	<b>HS</b>
	1198 SP	11 - 12	<b>HS</b>
	1199 Panigale	12 - 14	<b>HS</b>
	1199 Panigale R	13 - 15	<b>HS</b>
	1199 Panigale S	12 - 14	<b>HS</b>
	1199 Superleggera	14 - 14	<b>HS</b>
	1200 Monster 25		
	Anniversario	19 - 19	<b>HS</b>
	1200 Monster R	16 - 19	<b>HS</b>
	1200 Monster S	14 - 21	<b>HS</b>
	1200 Monster S Stripe	15 - 17	<b>HS</b>
	1200 Multistrada S	15 - 17	<b>HS</b>
	1200 Multistrada S		
	D-air	15 - 17	<b>HS</b>
	1200 Multistrada S		
	Pikes Peak	16 - 17	<b>HS</b>
	1200 Multistrada S		
	Touring ABS	15 - 16	<b>HS</b>
	1260 Multistrada	18 - 18	<b>HS</b>
	1260 Multistrada S	18 - 19	<b>HS</b>
	1260 Multistrada S		
	D-air	18 - 19	<b>HS</b>
	1260 Multistrada S		
	Grand Tour	20 - 20	<b>HS</b>
	1260 Multistrada S		
	Pikes Peak	18 - 19	<b>HS</b>
	1299 Panigale	15 - 17	<b>HS</b>
	1299 Panigale R	15 - 17	<b>HS</b>
	1299 Panigale R		
	Final Edition	17 - 20	<b>HS</b>
	1299 Panigale S	15 - 17	<b>HS</b>
	1299 Panigale S		
	Anniversario	17 - 17	<b>HS</b>
	1299 Superleggera	17 - 17	<b>HS</b>

<b>HONDA</b>			
CBR	1000 RR-R Fireblade	24 - 24	<b>HS</b>
CBR	1000 RR-R SP Fireblade	22 - 24	<b>HS</b>

<b>HOREX</b>			
VR6	1200 Cafe Racer	17 - 23	<b>HS</b>
VR6	1200 Classic	17 - 23	<b>HS</b>
VR6	1200 Raw	23 - 23	<b>HS</b>

<b>HUSQVARNA</b>			
FS	450	15 - 22	<b>RST</b>
	900 Nuda R, ABS	12 - 13	<b>HS</b>

<b>ITALJET</b>			
	500 Dragster	23 - 23	<b>HS</b>

<b>KAWASAKI</b>			
Z	1000 H2 SE	21 - 24	<b>HS</b>
Z	1000 R	17 - 18	<b>HS</b>
ZX	1000 H2 Carbon Ninja	17 - 20	<b>HS</b>
ZX	1000 H2 Ninja	15 - 21	<b>HS</b>
ZX	1000 H2 SX SE+	19 - 21	<b>HS</b>



<b>KAWASAKI</b>			
ZX	1000 H2R Ninja	15 - 24	<b>HS</b>
ZX-10R	1000 Ninja	16 - 24	<b>HS</b>
ZX-10R	1000 Ninja SE	18 - 22	<b>HS</b>
ZX-10RR	1000 Ninja	17 - 24	<b>HS</b>

<b>KTM</b>			
SX	450 SMR	13 - 15	<b>RST</b>
SX	450 SMR	21 - 22	<b>RST</b>
	690 Duke R	14 - 17	<b>HS</b>
RC8	890 C	22 - 22	<b>RST</b>
	990 Supermoto R	10 - 10	<b>HS</b>
RC8	1190	08 - 11	<b>HS</b>
RC8	1190 R	09 - 15	<b>HS</b>
RC8	1190 R Track	11 - 15	<b>HS</b>
	1290 Super Duke R	14 - 22	<b>HS</b>
	1290 Super Duke R		
	EVO	22 - 22	<b>HS</b>
	1290 Superduke R		
	Black	20 - 20	<b>HS</b>

<b>MOTO-MORINI</b>			
	750 Corsaro	24 - 24	<b>HS</b>
	750 Corsaro Sport	24 - 24	<b>HS</b>
	1200 X-Cape	24 - 24	<b>HS</b>

<b>MV AGUSTA</b>			
	550 Lucky Explorer	23 - 23	<b>HS</b>
	800 Superveloce	19 - 19	<b>HS</b>
F3	800 AMG GT	16 - 20	<b>HS</b>
F3	800 RR	21 - 23	<b>HS</b>
	950 9.5 LXP Orioli	24 - 24	<b>HS</b>
	950 Lucky Explorer	23 - 23	<b>HS</b>
	1000 Brutale RR	20 - 20	<b>HS</b>
	1000 Rush	20 - 20	<b>HS</b>
F4	1000 LH44	18 - 20	<b>HS</b>
F4	1000 R	12 - 19	<b>HS</b>
F4	1000 RC	15 - 20	<b>HS</b>
F4	1000 RR	12 - 20	<b>HS</b>
	1078 Brutale RR	09 - 09	<b>HS</b>
F4	1078 312 RR	08 - 11	<b>HS</b>
F4	1078 CC	08 - 11	<b>HS</b>
	1090 Brutale Corse	14 - 16	<b>HS</b>
	1090 Brutale RR	10 - 17	<b>HS</b>

<b>NORTON</b>			
	1200 V4 RR	18 - 19	<b>HS</b>

<b>QJ MOTOR</b>			
SRK	900 RR	24 - 24	<b>HS</b>

<b>SUZUKI</b>			
GSX-R	600	11 - 24	<b>HS</b>
GSX-R	750	11 - 23	<b>HS</b>
GSX-R	1000	12 - 24	<b>HS</b>
GSX-R	1000 R	17 - 24	<b>HS</b>
GSX-S	1000	15 - 24	<b>HS</b>
GSX-S	1000 F	15 - 23	<b>HS</b>
GSX-S	1000 GT	22 - 24	<b>HS</b>
GSX-S	1000 GX	24 - 24	<b>HS</b>
GSX-S	1000 Katana	19 - 24	<b>HS</b>
GSX-R	1300 Hayabusa	13 - 24	<b>HS</b>
GSX-R	1300 Hayabusa		
	(Red Call)	13 - 21	<b>HS</b>

<b>TRIUMPH</b>			
	2500 Rocket 3 GT	19 - 23	<b>HS</b>
	2500 Rocket 3 R	19 - 23	<b>HS</b>

<b>YAMAHA</b>			
MT-09	900 SP	24 - 24	<b>HS</b>



STREET  
AMERICAN  
SCOOTER

HF • HS • LS  
H.HF • H.CT • H.HS • H.LS  
HF • CT • MS

RACING  
OFF ROAD  
ATV

RST • DC • DCC • DS-1 • DS-2 • RQ  
SI • RSI • CS  
ATS • SI • RSI • PSI

Drawings 1:1

Available compounds

HS • DC • RST • DS-1 • DS-2

SBS 841

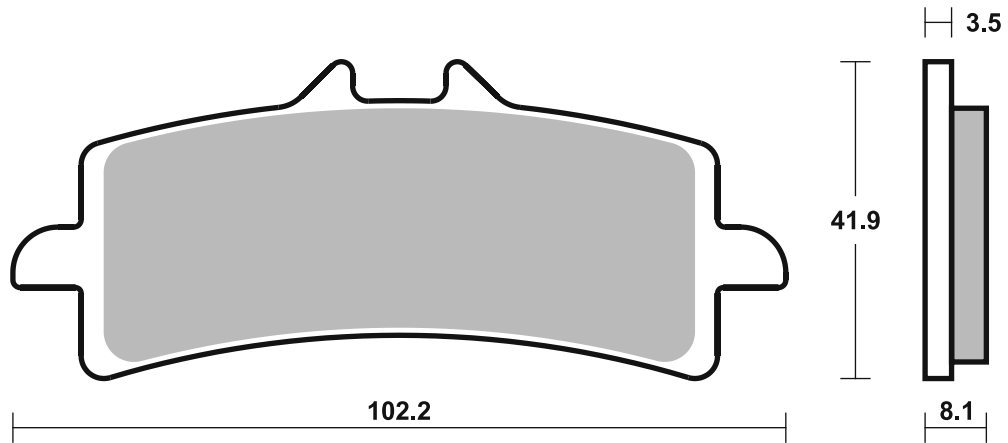

## Applications

### SBS 842

### Recommended compound



#### APRILIA

SXV	450	06 - 13	RSI
SXV	550	06 - 13	RSI
	650 Pegaso Factory	07 - 09	HS

#### HUSABERG

FS	450 c	06 - 08	RSI
FS	650 e, c	06 - 08	RSI

#### KTM

SX	450 SMR	04 - 06	RSI
SX	525 SMR	04 - 07	RSI

### SBS 843

### Recommended compound



#### HM

CRM	125 X Supermotard	07 - 07	RSI
CRM	250 X Supermotard	07 - 13	RSI
CRM	450 X Supermotard	07 - 13	RSI
CRM	500 X Supermotard	07 - 13	RSI

#### KTM

SX	450 SMR	07 - 12	RSI
SX	560 SMR	06 - 07	RSI

STREET  
AMERICAN  
SCOOTER

HF • HS • LS  
H.HF • H.CT • H.HS • H.LS  
HF • CT • MS

RACING  
OFF ROAD  
ATV

RST • DC • DCC • DS-1 • DS-2 • RQ  
SI • RSI • CS  
ATS • SI • RSI • PSI

Drawings 1:1

Available compounds

HS • RST • RSI

SBS 842

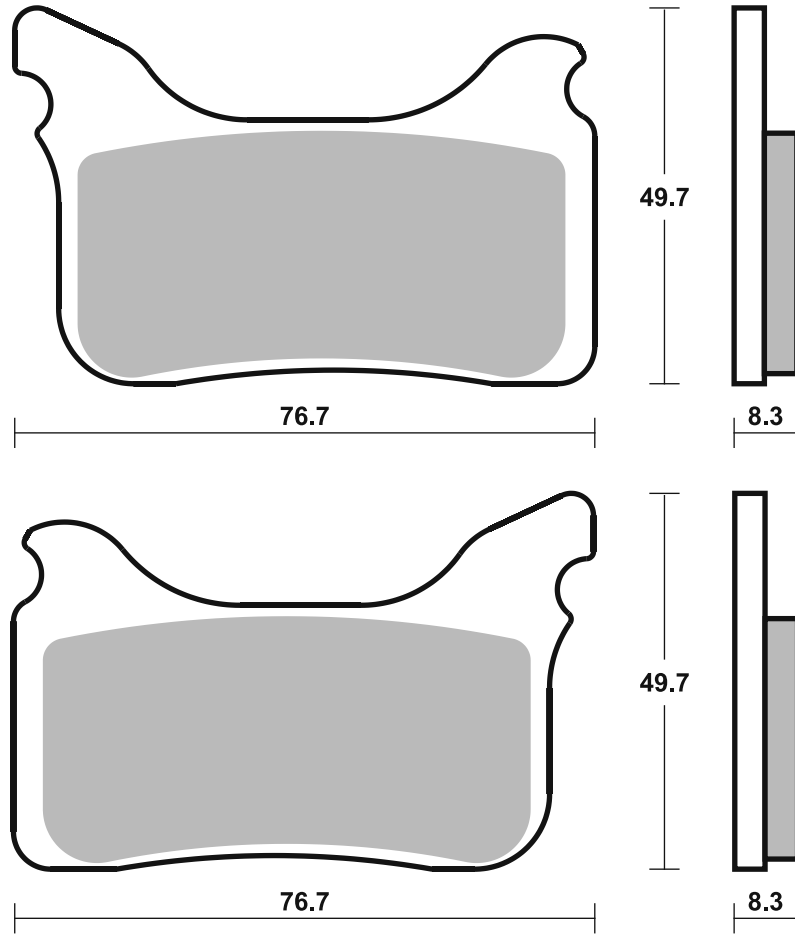

Available compounds

HS • DC • RST • RSI

SBS 843

1 set = 4 pcs.

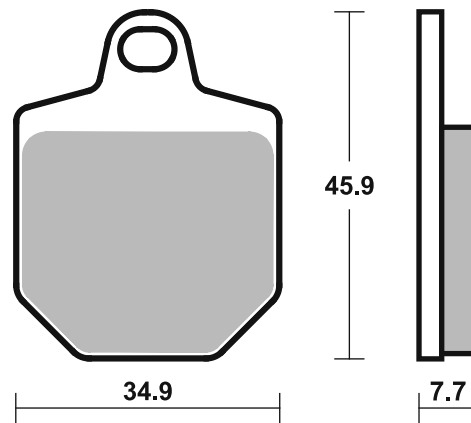

**Applications**

**SBS 844**

**Recommended compound**



**APRILIA**

RS	125	06 - 12	<b>HF</b>
SL	750 Shiver GT, ABS	09 - 12	<b>HS</b>
SL	750 Shiver, ABS	07 - 18	<b>HS</b>
SMV	750 Dorsoduro	09 - 18	<b>HS</b>
NA	850 Mana	07 - 07	<b>HS</b>
NA	850 Mana GT, ABS	09 - 13	<b>HS</b>
NA	850 Mana, ABS	08 - 11	<b>HS</b>
	900 Dorsoduro	18 - 20	<b>HS</b>
	900 Shiver	18 - 20	<b>HS</b>

**YAMAHA**

MT	125	14 - 24	<b>HF</b>
YZF	125 R	14 - 24	<b>HF</b>

**SBS 845**

**Recommended compound**



**ACCOSSATO**

AGPZ05, 100 mm CNC			
Monoblock, 4 Piston/2 Pad			
AGPZ07, 100 mm Forged			
Monoblock, 4 Piston/2 Pad			

**BMW**

S	1000 HP4 Race	17 - 18	<b>DS-1</b>
---	---------------	---------	-------------

**BREMBO RACING CALIPERS**

Radial Monoblock XA8Y310/11			
-----------------------------	--	--	--

STREET  
AMERICAN  
SCOOTER

HF • HS • LS  
H.HF • H.CT • H.HS • H.LS  
HF • CT • MS

RACING  
OFF ROAD  
ATV

RST • DC • DCC • DS-1 • DS-2 • RQ  
SI • RSI • CS  
ATS • SI • RSI • PSI

Drawings 1:1

Available compounds

HF • HS • DC • RST

SBS 844

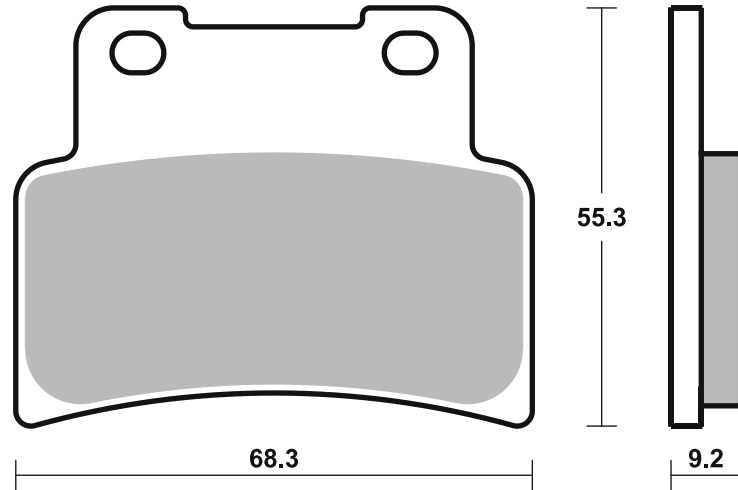

Available compounds

DC • DS-1 • DS-2

SBS 845

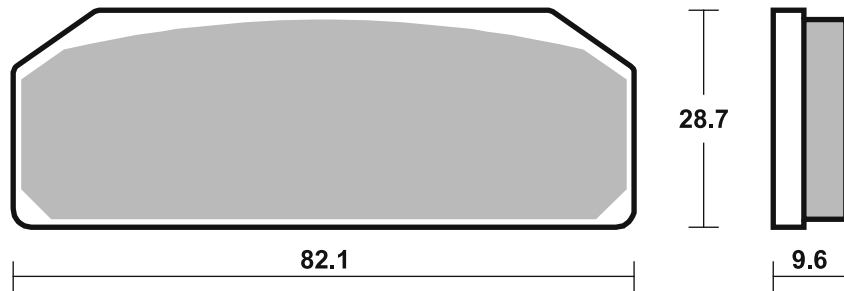

## SBS 846

## Recommended compound

**HARLEY DAVIDSON**

FLSTI	1450 Heritage Softail	06 - 06	H.LS
FXDI	1450 35th Anniversary		
	Super Glide	06 - 06	H.LS
FXST/I	1450 Softail Standard	06 - 06	H.LS
FXSTB/I	1450 Night Train	06 - 06	H.LS
FXSTD/I	1450 Softail Deuce	06 - 06	H.LS
FXSTS/I	1450 Softail	06 - 06	H.LS
FLSTC	1584 Heritage Softail		
	Classic	07 - 07	H.LS
FLSTF	1584 Fat Boy	07 - 07	H.LS
FLSTN	1584 Softail Deluxe	07 - 07	H.LS
FLSTSC/I	1584 Softail	07 - 07	H.LS
FXST	1584 Softail Standard	07 - 07	H.LS
FXSTB	1584 Night Train	07 - 07	H.LS
FXSTC	1584 Softail Custom	07 - 07	H.LS
FXSTD	1584 Softail Deuce	07 - 07	H.LS

## SBS 847

## Recommended compound

**DAELIM**

ST	250 Sector Quad	05 - 06	SI
<b>E-TON</b>			
RXL	150 Viper	07 - 07	SI
VXL	250 Vector, ST Vector	06 - 07	SI
VTX	300 Vortex, ST Vortex	07 - 07	SI
VXL	300 Vector, ST Vector	07 - 13	SI
<b>SYM</b>			
SB	125 Wolf Ni	11 - 13	HF
	200 Quadlander	12 - 13	SI
	200 Trackrunner	05 - 08	SI
	250 Quadlander	06 - 07	SI
	300 City Max	06 - 07	SI

STREET  
AMERICAN  
SCOOTER

HF • HS • LS  
H.HF • H.CT • H.HS • H.LS  
HF • CT • MS

RACING  
OFF ROAD  
ATV

RST • DC • DCC • DS-1 • DS-2 • RQ  
SI • RSI • CS  
ATS • SI • RSI • PSI

Drawings 1:1

Available compounds

H.HF • H.CT • H.LS

SBS 846

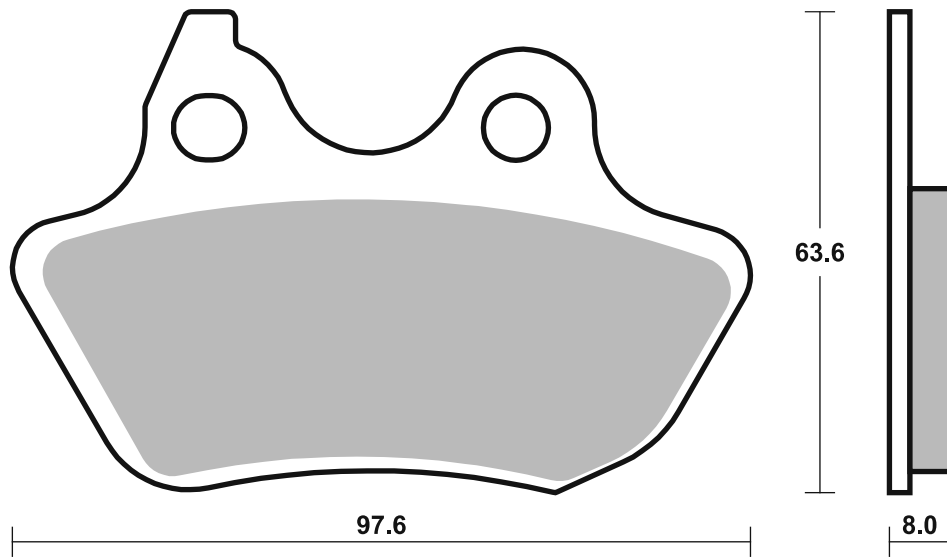
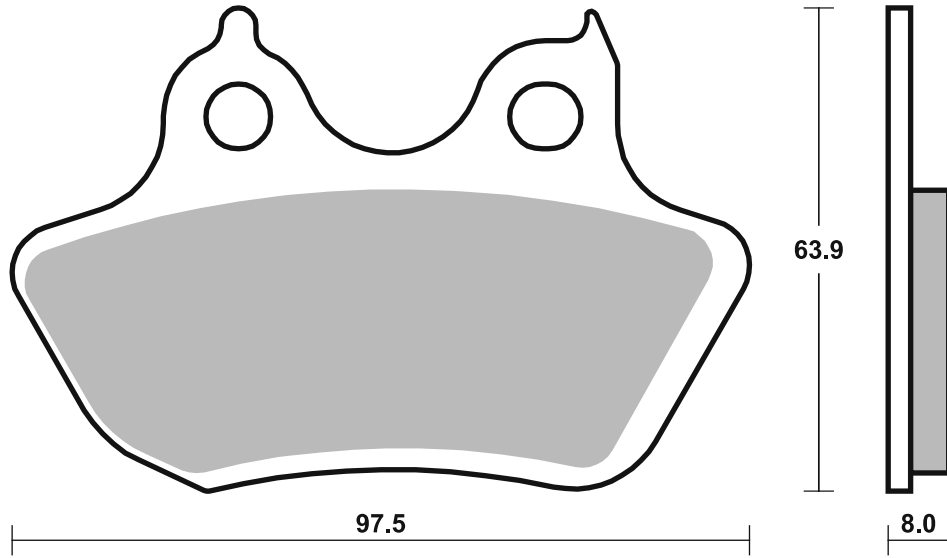

Available compounds

HF • HS • SI • RSI

SBS 847

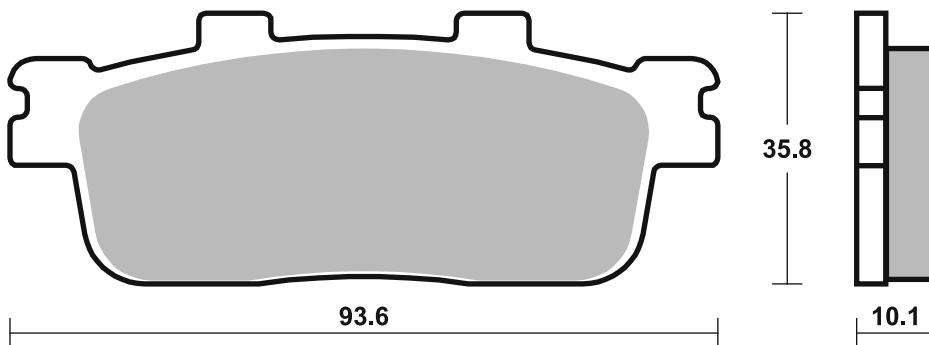

Applications

**SBS 848 Recommended compound**



**ADLY**

ATV	300 Sport	07 - 13	SI
-----	-----------	---------	----

**CPI**

XS	250 Quad	06 - 08	SI
----	----------	---------	----

**PGO**

BR	200 Bugrider	07 - 07	HF
----	--------------	---------	----

BR	250 Bugrider	05 - 12	HF
----	--------------	---------	----

**QUADZILLA**

XRV	250 ,E	06 - 07	HF
-----	--------	---------	----

**SBS 849 Recommended compound**



**YAMAHA**

YFM	250 Raptor	09 - 14	SI
-----	------------	---------	----

YFM	550 FGPW Grizzly	09 - 16	SI
-----	------------------	---------	----

YFM	700 FGPW Grizzly	07 - 17	SI
-----	------------------	---------	----

Brake Pad 1:1 Drawings,  
Compounds, Fitments



STREET  
AMERICAN  
SCOOTER

HF • HS • LS  
H.HF • H.CT • H.HS • H.LS  
HF • CT • MS

RACING  
OFF ROAD  
ATV

RST • DC • DCC • DS-1 • DS-2 • RQ  
SI • RSI • CS  
ATS • SI • RSI • PSI

Drawings 1:1

Available compounds

HF • SI

SBS 848

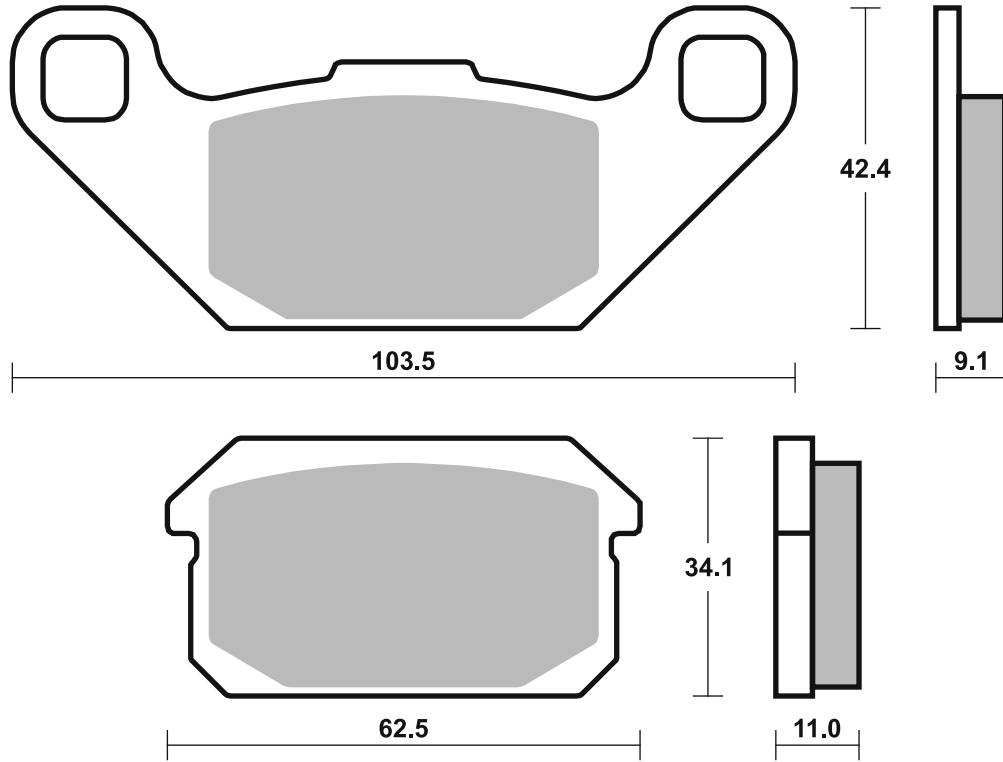

Available compounds

SI • RSI

SBS 849

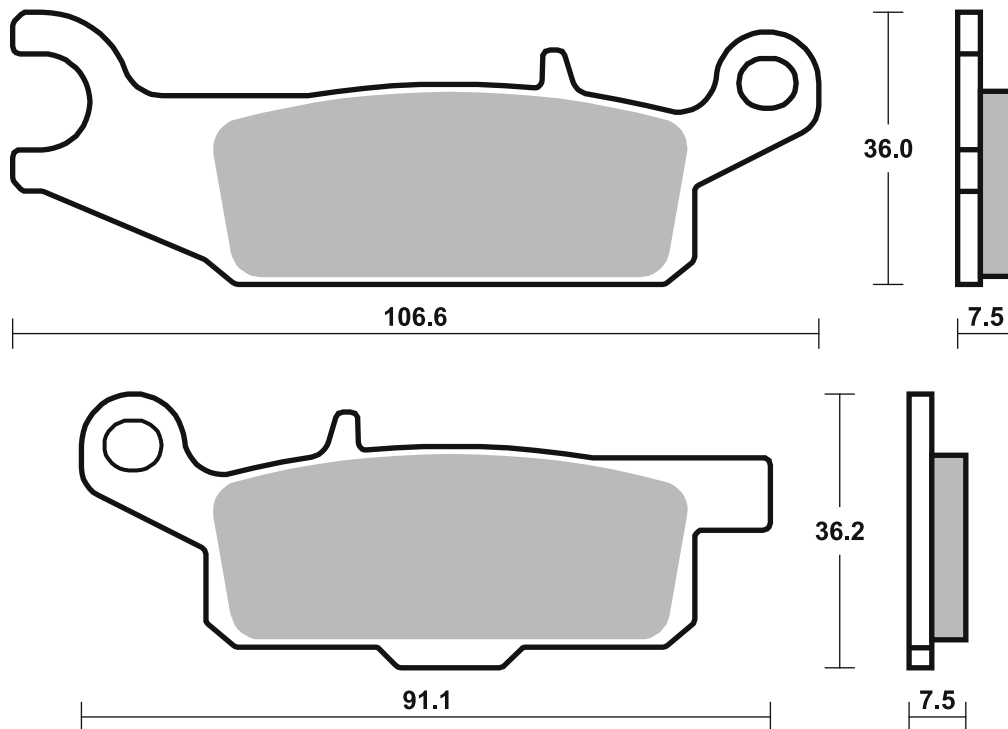



STREET  
AMERICAN  
SCOOTER

HF • HS • LS  
H.HF • H.CT • H.HS • H.LS  
HF • CT • MS

RACING  
OFF ROAD  
ATV

RST • DC • DCC • DS-1 • DS-2 • RQ  
SI • RSI • CS  
ATS • SI • RSI • PSI

Drawings 1:1

Available compounds

SI • RSI

SBS 850

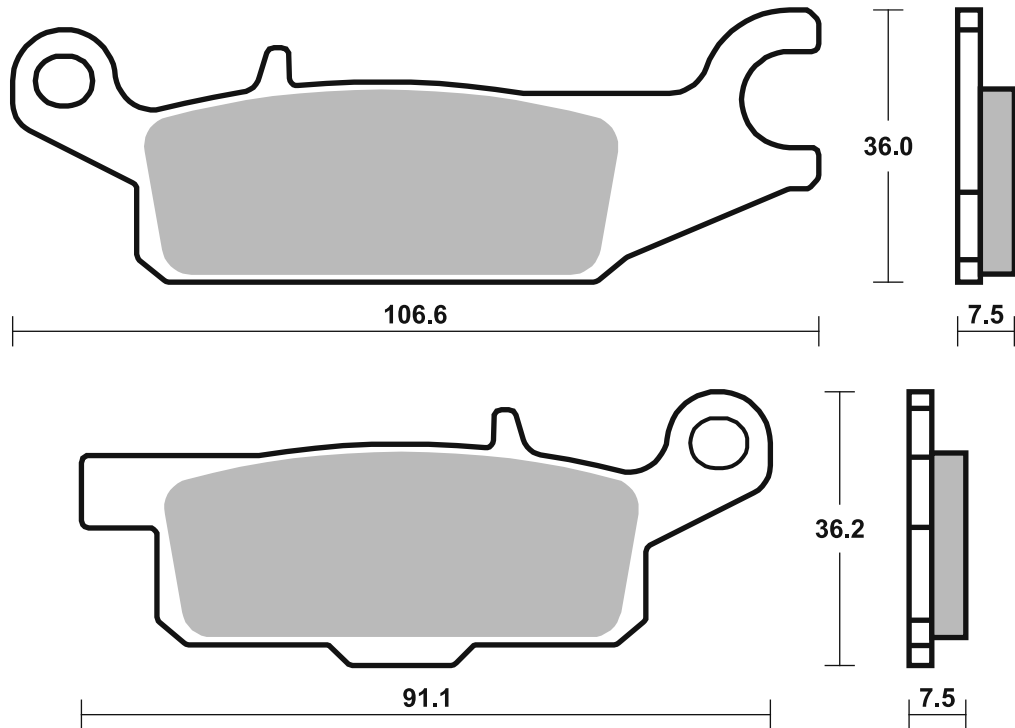

Available compounds

SI • RSI

SBS 851

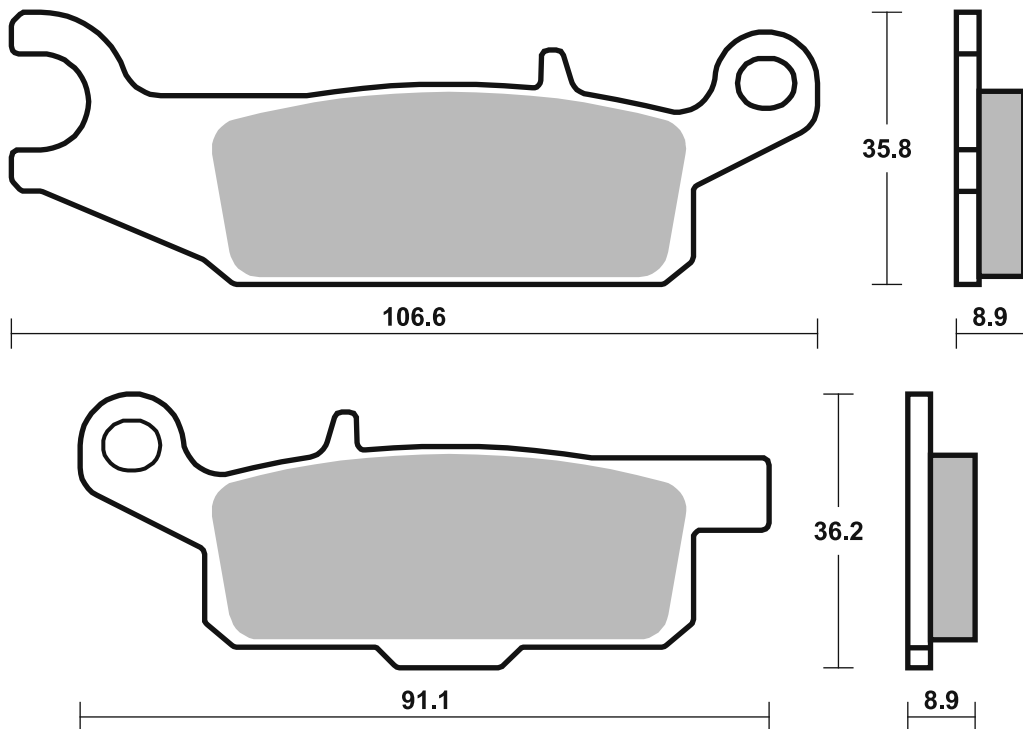



STREET  
AMERICAN  
SCOOTER

HF • HS • LS  
H.HF • H.CT • H.HS • H.LS  
HF • CT • MS

RACING  
OFF ROAD  
ATV

RST • DC • DCC • DS-1 • DS-2 • RQ  
SI • RSI • CS  
ATS • SI • RSI • PSI

Drawings 1:1

Available compounds

SI • RSI

SBS 852

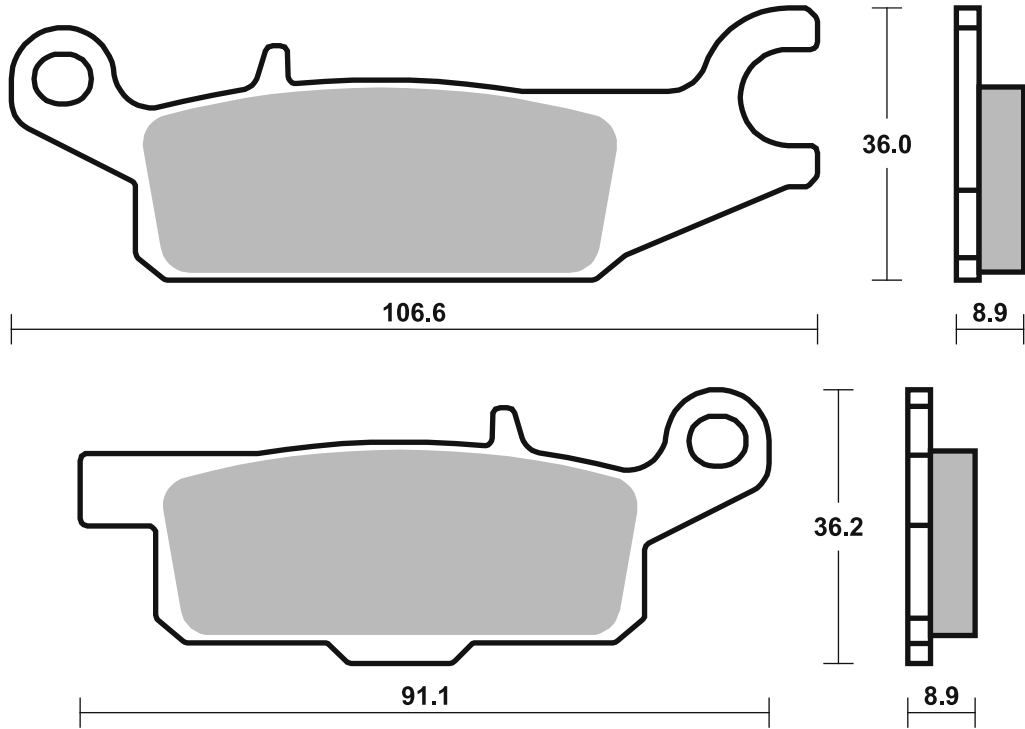



**HARLEY DAVIDSON**

FLSTC	1584 Heritage Softail		
	Classic	08 - 11	<b>H.HS</b>
FLSTF	1584 Fat Boy	08 - 11	<b>H.HS</b>
FLSTFB	1584 Fat Boy Special	10 - 11	<b>H.HS</b>
FLSTN	1584 Softail Deluxe	08 - 11	<b>H.HS</b>
FXCW	1584 Rocker	08 - 09	<b>H.HS</b>
FXCWC	1584 Rocker C	08 - 13	<b>H.HS</b>
FXD	1584 Dyna Super		
	Glide	08 - 10	<b>H.HS</b>
FXDB	1584 Dyna Street Bob	08 - 13	<b>H.HS</b>
FXDC	1584 Dyna Super		
	Glide Custom	08 - 13	<b>H.HS</b>
FXDF	1584 Fat Bob	08 - 11	<b>H.HS</b>
FXDL	1584 Dyna Low Rider	08 - 13	<b>H.HS</b>
FXDWG	1584 Dyna Wide Glide	08 - 10	<b>H.HS</b>
FXST	1584 Softail Standard	08 - 14	<b>H.HS</b>
FXSTB	1584 Night Train	08 - 09	<b>H.HS</b>
FXSTC	1584 Softail Custom	08 - 10	<b>H.HS</b>
FLD	1690 Switchback	12 - 16	<b>H.HS</b>
FLHTC	1690 Electra Glide		
	Classic	11 - 16	<b>H.HS</b>
FLHTK	1690 Ultra Electra		
	Glide	11 - 16	<b>H.HS</b>
FLS	1690 Softail Slim	12 - 14	<b>H.HS</b>
FLSTC	1690 Heritage Softail		
	Classic	12 - 14	<b>H.HS</b>
FLSTF	1690 Fat Boy	12 - 14	<b>H.HS</b>
FLSTF	1690 Fat Boy Special	12 - 14	<b>H.HS</b>
FLSTFB	1690 Fat Boy	12 - 14	<b>H.HS</b>
FLSTN	1690 Softail Deluxe	12 - 14	<b>H.HS</b>
FXDB	1690 Dyna Street Bob	14 - 17	<b>H.HS</b>
FXDBA	1690 Dyna Street Bob	13 - 17	<b>H.HS</b>
FXDBB	1690 Dyna Street Bob	14 - 17	<b>H.HS</b>
FXDBP	1690 Dyna Street Bob	13 - 17	<b>H.HS</b>
FXDC	1690 Dyna Super		
	Glide Custom	14 - 14	<b>H.HS</b>
FXDF	1690 Dyna Wide Glide	12 - 17	<b>H.HS</b>
FXDF	1690 Fat Bob	12 - 17	<b>H.HS</b>
FXDL	1690 Dyna Low Rider	14 - 17	<b>H.HS</b>
FXDLS	1690 Dyna Low Rider		
	S	17 - 17	<b>H.HS</b>
FXS	1690 Blackline	13 - 17	<b>H.HS</b>
FXSB	1690 Breakout	14 - 14	<b>H.HS</b>
FLSTNSE	1802 CVO Softail		
	Deluxe	14 - 14	<b>H.HS</b>
FXSBSE	1802 CVO Breakout	13 - 14	<b>H.HS</b>

Brake Pad 1:1 Drawings,  
Compounds, Fitments

STREET  
AMERICAN  
SCOOTER

HF • HS • LS  
H.HF • H.CT • H.HS • H.LS  
HF • CT • MS

RACING  
OFF ROAD  
ATV

RST • DC • DCC • DS-1 • DS-2 • RQ  
SI • RSI • CS  
ATS • SI • RSI • PSI

Drawings 1:1

Available compounds

H.HF • H.CT • H.HS

SBS 853

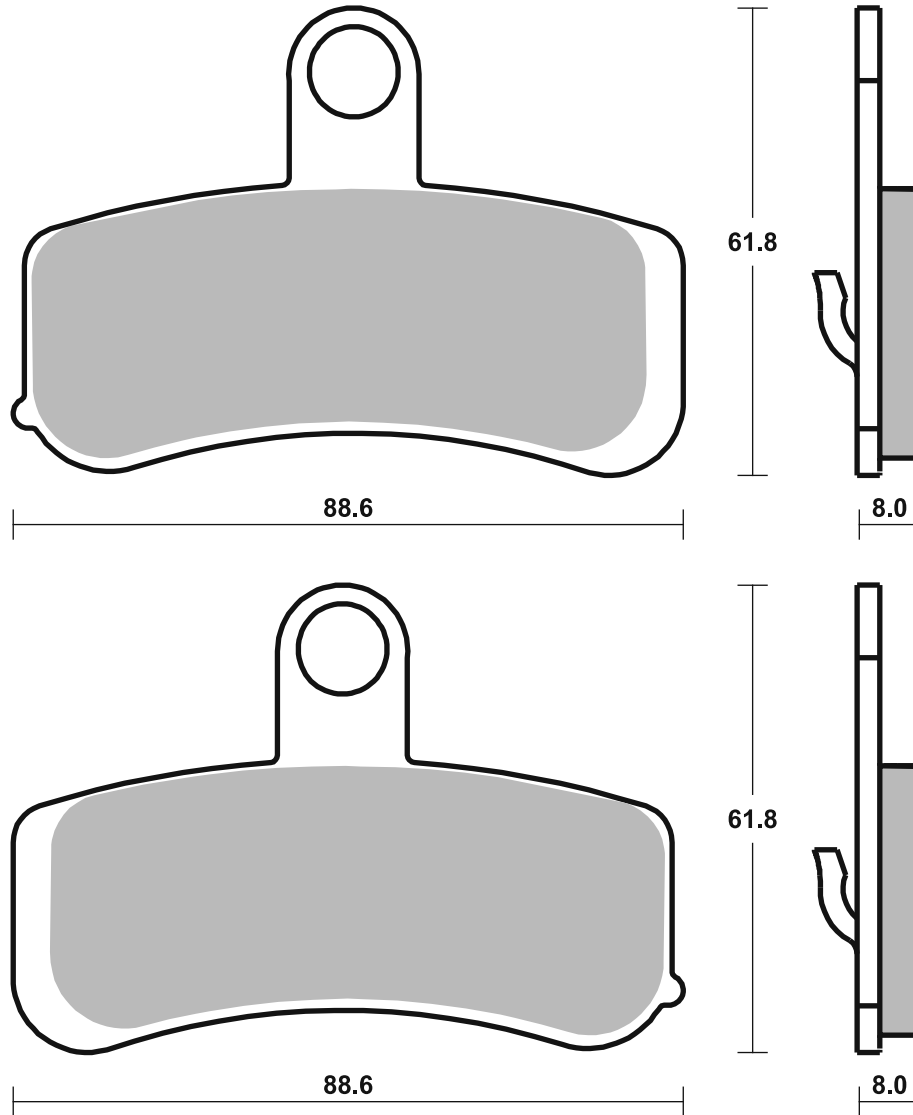

# Applications

## SBS 854 Recommended compound



<b>HARLEY DAVIDSON</b>			
FLSTC	1584 Heritage Softail		
	Classic	08 - 11	<b>H.LS</b>
FLSTF	1584 Fat Boy	08 - 11	<b>H.LS</b>
FLSTFB	1584 Fat Boy Special	10 - 11	<b>H.LS</b>
FLSTN	1584 Softail Deluxe	08 - 11	<b>H.LS</b>
FXCW	1584 Rocker	08 - 09	<b>H.LS</b>
FXCWC	1584 Rocker C	08 - 13	<b>H.LS</b>
FXD	1584 Dyna Super Glide	08 - 10	<b>H.LS</b>
FXDB	1584 Dyna Street Bob	08 - 13	<b>H.LS</b>
FXDC	1584 Dyna Super Glide		
	Custom	08 - 13	<b>H.LS</b>
FXDF	1584 Fat Bob	08 - 11	<b>H.LS</b>
FXDL	1584 Dyna Low Rider	08 - 13	<b>H.LS</b>
FXDWG	1584 Dyna Wide Glide	08 - 10	<b>H.LS</b>
FXST	1584 Softail Standard	08 - 17	<b>H.LS</b>
FXSTB	1584 Night Train	08 - 09	<b>H.LS</b>
FXSTC	1584 Softail Custom	08 - 10	<b>H.LS</b>
FLD	1690 Switchback	12 - 16	<b>H.LS</b>
FLHTC	1690 Electra Glide		
	Classic	11 - 16	<b>H.LS</b>
FLHTK	1690 Ultra Electra Glide	11 - 16	<b>H.LS</b>
FLS	1690 Softail Slim	12 - 17	<b>H.LS</b>
FLSTC	1690 Heritage Softail		
	Classic	12 - 17	<b>H.LS</b>
FLSTF	1690 Fat Boy	12 - 17	<b>H.LS</b>
FLSTF	1690 Fat Boy Special	12 - 14	<b>H.LS</b>
FLSTFB	1690 Fat Boy	12 - 17	<b>H.LS</b>
FLSTN	1690 Softail Deluxe	12 - 17	<b>H.LS</b>
FXDB	1690 Dyna Street Bob	14 - 17	<b>H.LS</b>
FXDBA	1690 Dyna Street Bob	13 - 17	<b>H.LS</b>
FXDBB	1690 Dyna Street Bob	14 - 17	<b>H.LS</b>
FXDBP	1690 Dyna Street Bob	13 - 17	<b>H.LS</b>
FXDC	1690 Dyna Super Glide		
	Custom	14 - 14	<b>H.LS</b>
FXDF	1690 Dyna Wide Glide	12 - 17	<b>H.LS</b>



<b>HARLEY DAVIDSON</b>			
FXDF	1690 Fat Bob	12 - 17	<b>H.LS</b>
FXDL	1690 Dyna Low Rider	14 - 17	<b>H.LS</b>
FXDLS	1690 Dyna Low Rider		
	S	17 - 17	<b>H.LS</b>
FXS	1690 Blackline	13 - 17	<b>H.LS</b>
FXSB	1690 Breakout	14 - 17	<b>H.LS</b>
FLSS	1802 Softail Slim S	16 - 17	<b>H.LS</b>
FLSTFBS	1802 Fat Boy S	16 - 17	<b>H.LS</b>
FLSTNSE	1802 CVO Softail		
	Deluxe	14 - 17	<b>H.LS</b>
FXSBSE	1802 CVO Breakout	13 - 14	<b>H.LS</b>

## SBS 855 Recommended compound



<b>PGO</b>			
	50 Bugrider	06 - 06	<b>HF</b>
BR	150 Bugxter	05 - 07	<b>HF</b>
BR	200 Bugrider	07 - 07	<b>HF</b>
BR	250 Bugrider	05 - 12	<b>HF</b>

<b>QUADZILLA</b>			
XRV	250 , E	06 - 07	<b>HF</b>



STREET  
AMERICAN  
SCOOTER

HF • HS • LS  
H.HF • H.CT • H.HS • H.LS  
HF • CT • MS

RACING  
OFF ROAD  
ATV

RST • DC • DCC • DS-1 • DS-2 • RQ  
SI • RSI • CS  
ATS • SI • RSI • PSI

Drawings 1:1

Available compounds

H.HF • H.CT • H.LS

SBS 854

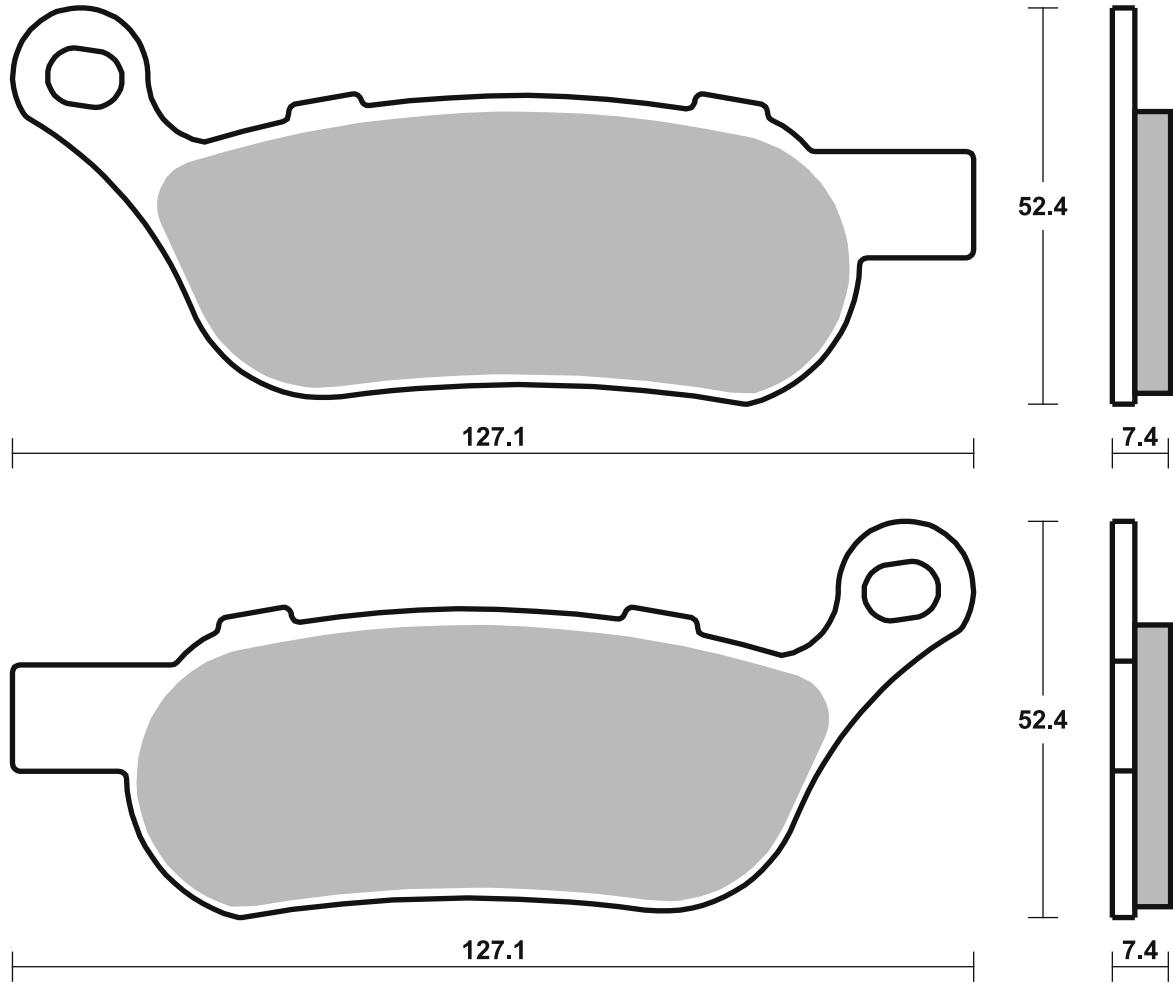

Available compounds

HF

SBS 855

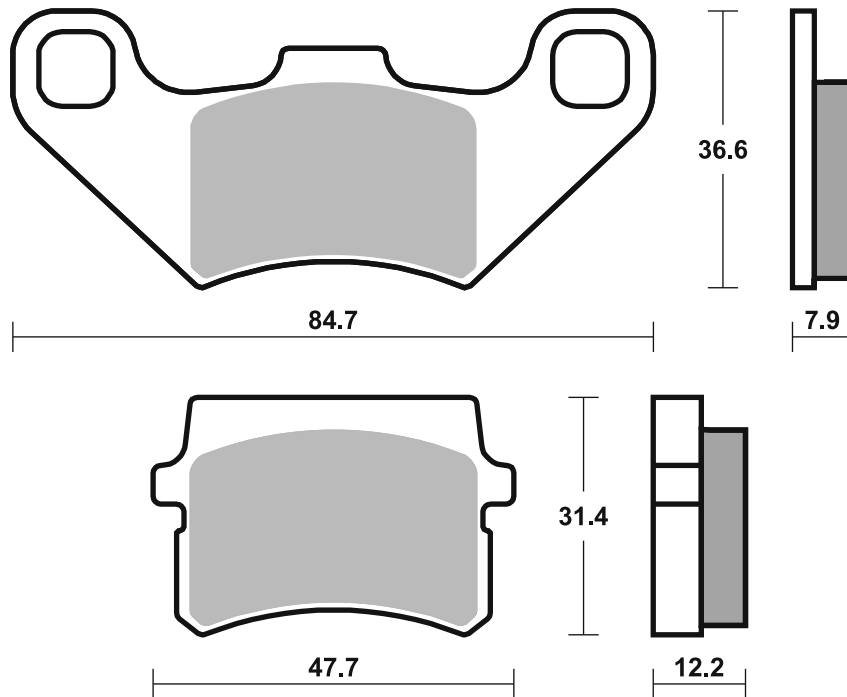

## Applications

### SBS 856 Recommended compound



<b>BUELL</b>			
	1125 CR	09 - 10	<b>HS</b>
	1125 R	08 - 10	<b>HS</b>
XB12R	1200 Firebolt	09 - 10	<b>HS</b>
XB12Scg	1200 Lightning	09 - 10	<b>HS</b>
XB12Ss	1200 Lightning Long	09 - 10	<b>HS</b>
<b>EBR</b>			
	1190 RS	12 - 15	<b>HS</b>
	1190 RX	14 - 15	<b>HS</b>
	1190 SX	14 - 15	<b>HS</b>

### SBS 857 Recommended compound



<b>BUELL</b>			
	1125 CR	09 - 10	<b>LS</b>
	1125 R	08 - 10	<b>LS</b>
<b>EBR</b>			
	1190 RS	12 - 15	<b>LS</b>
	1190 RX	14 - 15	<b>LS</b>
	1190 SX	14 - 15	<b>LS</b>

### SBS 858 Recommended compound



<b>YAMAHA</b>			
XC	125 Vity	08 - 13	<b>HF</b>
XSR	125	22 - 24	<b>HF</b>
YBR	125	08 - 16	<b>HF</b>
YS	125	17 - 19	<b>HF</b>
	135 Crypton X	08 - 14	<b>HF</b>
YZF	150 R15	14 - 14	<b>HF</b>

Brake Pad 1:1 Drawings, Compounds, Fitments

STREET  
AMERICAN  
SCOOTER

HF • HS • LS  
H.HF • H.CT • H.HS • H.LS  
HF • CT • MS

RACING  
OFF ROAD  
ATV

RST • DC • DCC • DS-1 • DS-2 • RQ  
SI • RSI • CS  
ATS • SI • RSI • PSI

Drawings 1:1

Available compounds

HS • RST • DS-1

SBS 856

1 set = 4 pcs.

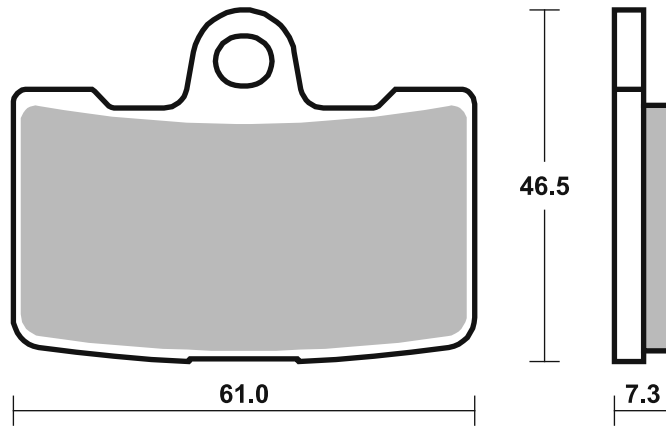

Available compounds

LS

SBS 857

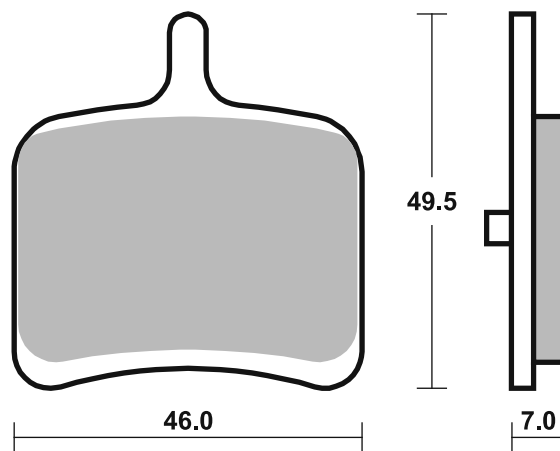

Available compounds

HF

SBS 858

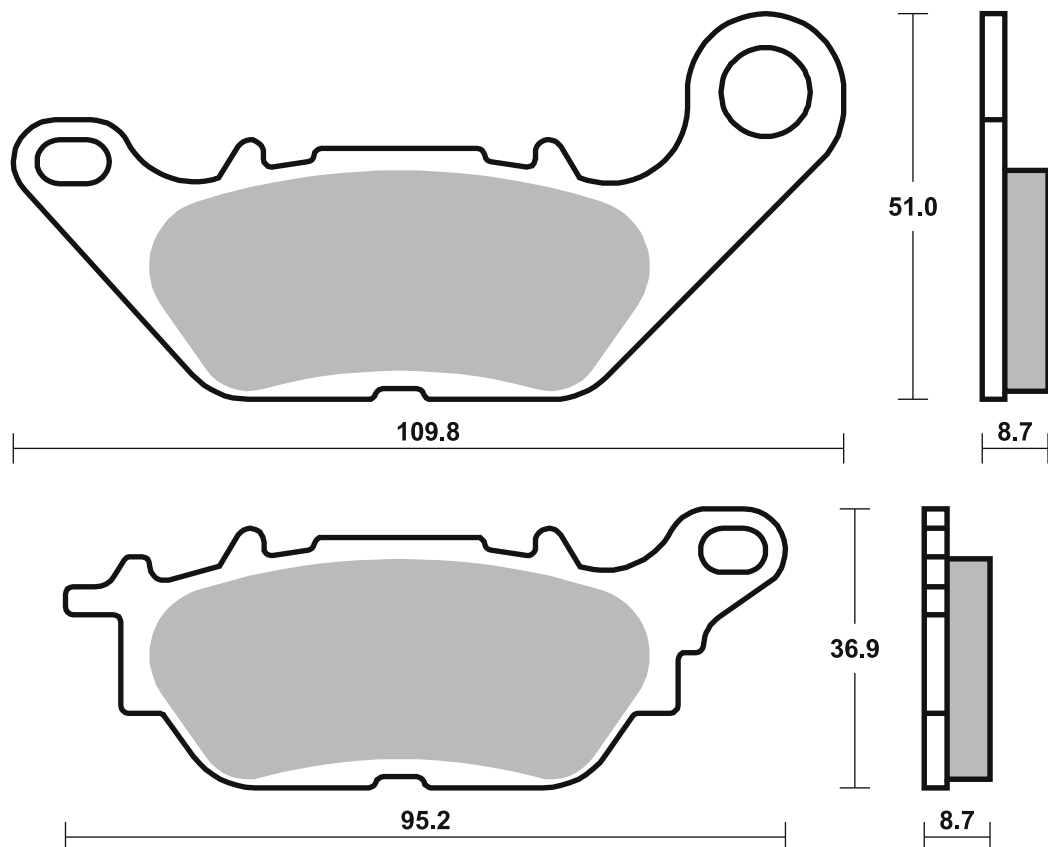

Dimensions in mm / Dimensions en mm  
1" = 25.4 mm, 1 mm = 0.04"

Brake Pad 1:1 Drawings,  
Compounds, Fitments

## Applications

### SBS 859

### Recommended compound



<b>AJP</b>			
PR3	125 Enduro	13 - 15	<b>HF</b>
PR3	125 Enduro Pro	13 - 15	<b>HF</b>
PR3	125 Extreme	13 - 15	<b>HF</b>
PR3	125 Supermoto	13 - 15	<b>HF</b>
PR4	125 Enduro	13 - 15	<b>HF</b>
PR4	125 Enduro Pro	13 - 15	<b>HF</b>
PR4	125 Supermoto	13 - 15	<b>HF</b>
PR4	125 Trail	13 - 15	<b>HF</b>
PR3	240 MX	13 - 15	<b>SI</b>
PR5	250 Enduro	10 - 15	<b>HF</b>
PR5	250 Extreme	12 - 15	<b>HF</b>
PR5	250 Supermoto	10 - 15	<b>HF</b>
PR7	650 Adventure	17 - 17	<b>HF</b>
<b>DERBI</b>			
	125 Mulhacen	08 - 11	<b>HF</b>
	125 Terra	08 - 13	<b>HF</b>
	125 Terra Adventure	08 - 14	<b>HF</b>
<b>HONDA</b>			
CRE	125 RR	11 - 11	<b>SI</b>
CRF	250 L	13 - 15	<b>SI</b>
CRF	250 L ABS	17 - 21	<b>SI</b>
CRF	250 M	14 - 18	<b>SI</b>
CRF	250 Rally	17 - 19	<b>SI</b>
CRF	300 L	21 - 21	<b>SI</b>
CRF	300 Rally	21 - 21	<b>SI</b>
XL	750 Transalp	23 - 24	<b>HS</b>
<b>SCORPA</b>			
	250 T-Ride	08 - 11	<b>HF</b>

### SBS 860

### Recommended compound



<b>HARLEY DAVIDSON</b>			
XR	1200	08 - 10	<b>H.HS</b>
XR	1200 X	10 - 13	<b>H.HS</b>
FXST	1584 Softail Standard	15 - 17	<b>H.HS</b>
FLS	1690 Softail Slim	15 - 17	<b>H.HS</b>
FLSTC	1690 Heritage Softail		
	Classic	15 - 17	<b>H.HS</b>
FLSTF	1690 Fat Boy	15 - 17	<b>H.HS</b>
FLSTFB	1690 Fat Boy	15 - 17	<b>H.HS</b>
FLSTN	1690 Softail Deluxe	15 - 17	<b>H.HS</b>
FXSB	1690 Breakout	15 - 17	<b>H.HS</b>
FLDE	1750 Softail Deluxe	18 - 19	<b>H.HS</b>
FLFB	1750 Fat Boy	18 - 20	<b>H.HS</b>
FLHC	1750 Heritage Classic	18 - 19	<b>H.HS</b>
FLSB	1750 Sport Glide	18 - 20	<b>H.HS</b>
FLSL	1750 Softail Slim	18 - 20	<b>H.HS</b>
FXBB	1750 Street Bob	18 - 22	<b>H.HS</b>
FXBR	1750 Breakout	18 - 19	<b>H.HS</b>
FXFB	1750 Fat Bob	18 - 20	<b>H.HS</b>
FXLR	1750 Low Rider	18 - 20	<b>H.HS</b>
FXST	1750 Softail Standard	22 - 22	<b>H.HS</b>
FLSS	1802 Softail Slim S	16 - 17	<b>H.HS</b>
FLSTFBS	1802 Fat Boy S	16 - 17	<b>H.HS</b>
FLSTNSE	1802 CVO Softail		
	Deluxe	15 - 17	<b>H.HS</b>
FLFBS	1870 Fat Boy	18 - 22	<b>H.HS</b>
FLHCS	1870 Heritage Classic	18 - 22	<b>H.HS</b>
FXBBS	1870 Street Bob	22 - 22	<b>H.HS</b>
FXBRS	1870 Breakout	18 - 20	<b>H.HS</b>
FXDR	1870	19 - 20	<b>H.HS</b>
FXFBS	1870 Fat Bob	18 - 22	<b>H.HS</b>
FXLRS	1917 Low Rider S	22 - 22	<b>H.HS</b>



<b>HARLEY DAVIDSON</b>			
FXLRST	1917 Low Rider ST	22 - 22	<b>H.HS</b>
<b>KAWASAKI</b>			
ZX-6R	636 Ninja Upgrade		
	DS	13 - 24	<b>H.HS</b>

STREET  
AMERICAN  
SCOOTER

HF • HS • LS  
H.HF • H.CT • H.HS • H.LS  
HF • CT • MS

RACING  
OFF ROAD  
ATV

RST • DC • DCC • DS-1 • DS-2 • RQ  
SI • RSI • CS  
ATS • SI • RSI • PSI

Drawings 1:1

Available compounds

HF • HS • SI • RSI

SBS 859

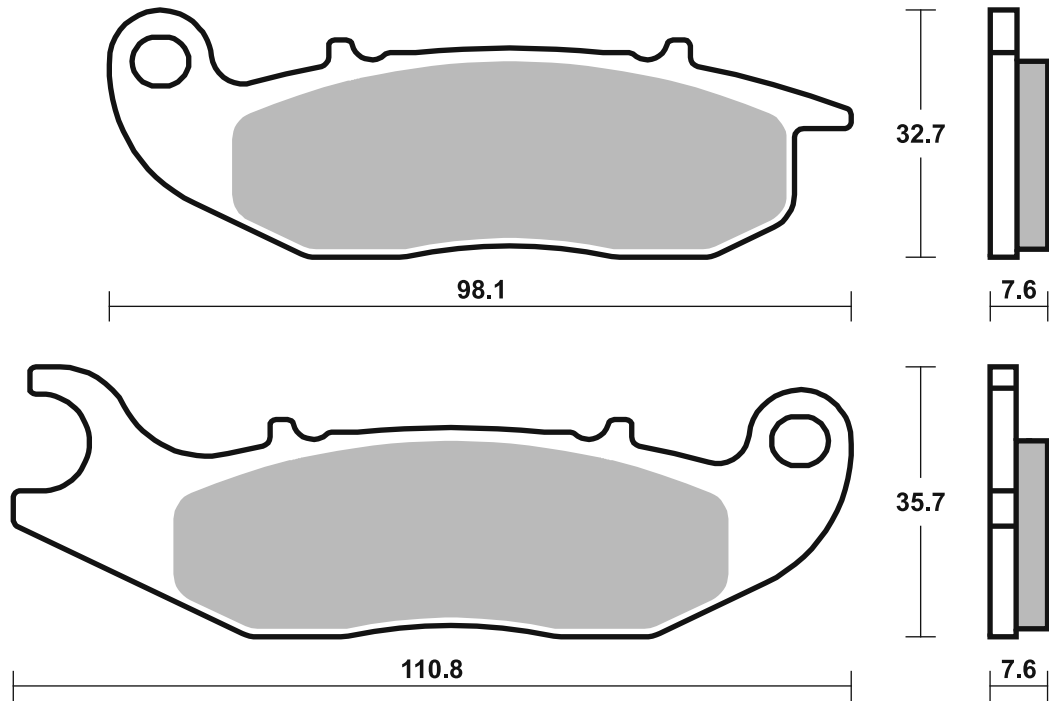

Available compounds

DS-1 • DS-2 • H.HF • H.CT • H.HS

SBS 860

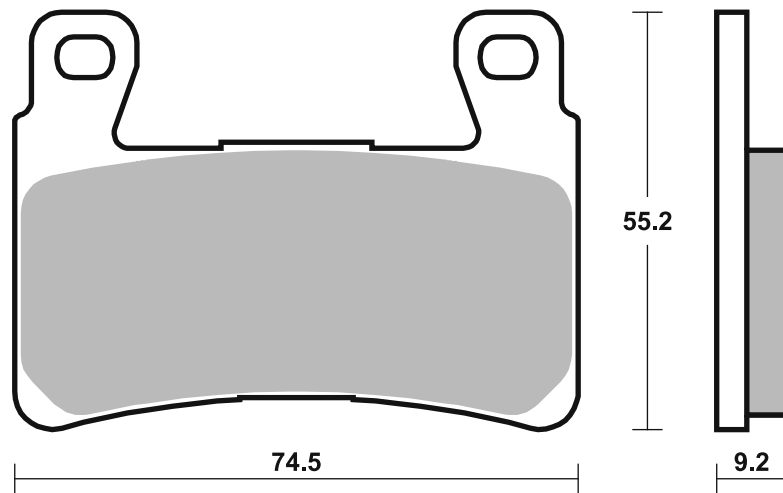

## Applications

### SBS 861 Recommended compound



<b>BETA</b>			
	125 M4	06 - 06	<b>HF</b>
	125 Urban	10 - 15	<b>HF</b>
ALP	125 4-stroke	06 - 09	<b>HF</b>
RR	125 Enduro 4T	10 - 15	<b>HF</b>
RR	125 Supermotard	08 - 09	<b>HF</b>
	200 Urban	10 - 10	<b>HF</b>
ALP	200 4-stroke	06 - 20	<b>HF</b>
	350 M4 (Brembo cal.)	06 - 07	<b>HF</b>
ALP	350 4.0	06 - 18	<b>HF</b>

### SBS 862 Recommended compound



<b>HONDA</b>			
VFR	800 Crossrunner	11 - 13	<b>LS</b>
VFR	800 F	14 - 19	<b>LS</b>
VFR	800 X Crossrunner	15 - 18	<b>LS</b>
CB	1000 R	08 - 16	<b>LS</b>
CB	1000 R	18 - 24	<b>LS</b>
CB	1000 R ABS	08 - 16	<b>LS</b>
CB	1000 R+ Neo Sports		
	Cafe	18 - 18	<b>LS</b>
VFR	1200 F	10 - 19	<b>LS</b>

Brake Pad 1:1 Drawings, Compounds, Fitments

STREET  
AMERICAN  
SCOOTER

HF • HS • LS  
H.HF • H.CT • H.HS • H.LS  
HF • CT • MS

RACING  
OFF ROAD  
ATV

RST • DC • DCC • DS-1 • DS-2 • RQ  
SI • RSI • CS  
ATS • SI • RSI • PSI

Drawings 1:1

Available compounds

HF

SBS 861

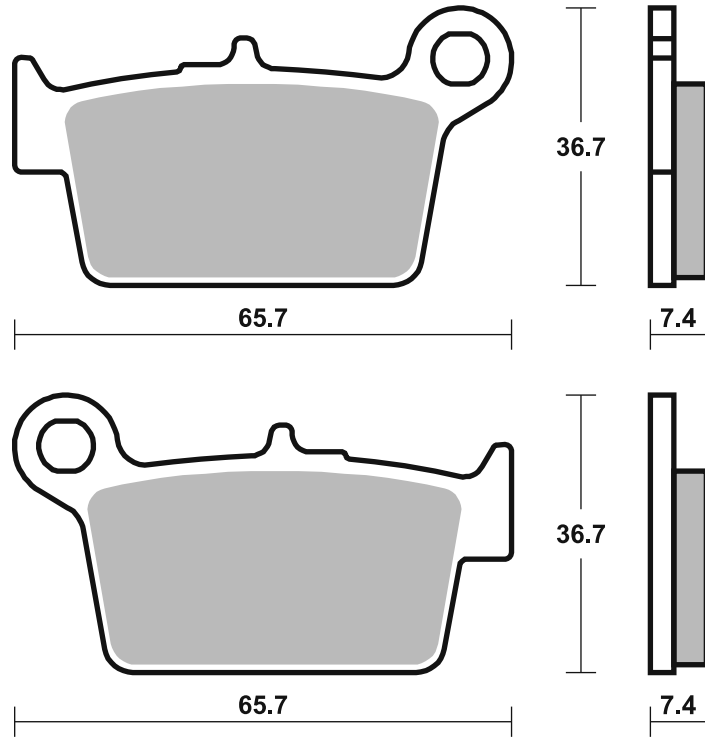

Available compounds

HF • LS

SBS 862

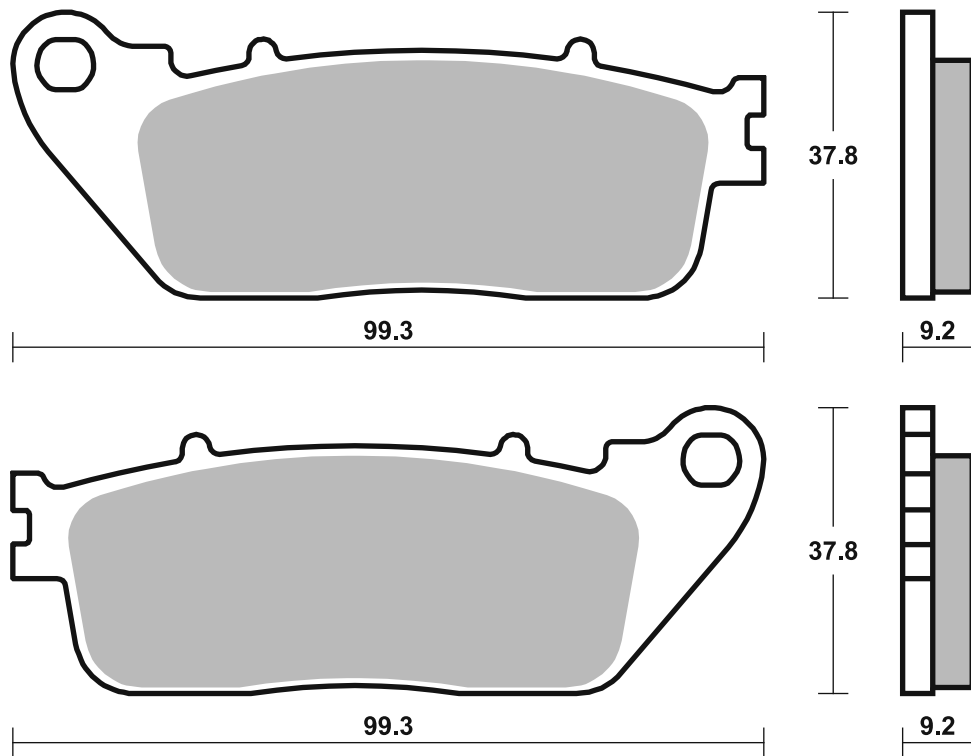

## Applications

### SBS 864 Recommended compound



TRIUMPH			
675 Daytona Triple	09 - 18	HS	

### SBS 865 Recommended compound



NISSIN			
6 Piston Racing Radial			
Monobloc Caliper (Z0901)			

### SBS 866 Recommended compound



KTM			
SX	450 ATV	08 - 10	RSI
XC	450 ATV	08 - 10	SI
SX	505 ATV	08 - 12	RSI
XC	505 ATV	08 - 12	SI

Brake Pad 1:1 Drawings, Compounds, Fitments



STREET  
AMERICAN  
SCOOTER

HF • HS • LS  
H.HF • H.CT • H.HS • H.LS  
HF • CT • MS

RACING  
OFF ROAD  
ATV

RST • DC • DCC • DS-1 • DS-2 • RQ  
SI • RSI • CS  
ATS • SI • RSI • PSI

Drawings 1:1

Available compounds

HS • DC • RST

SBS 864

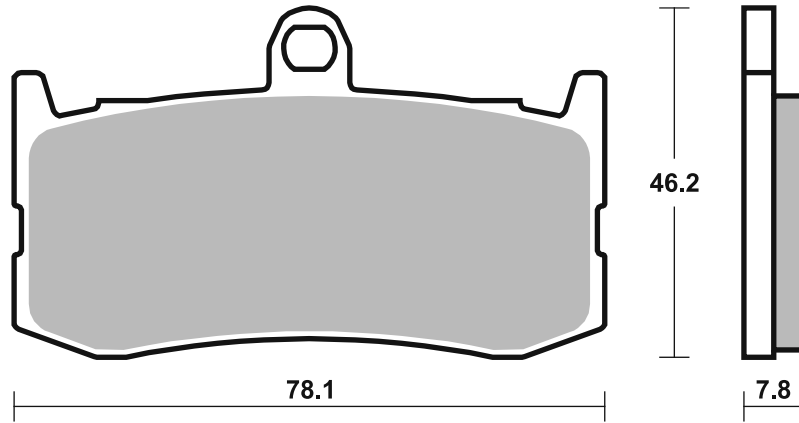

Available compounds

DS-1

SBS 865

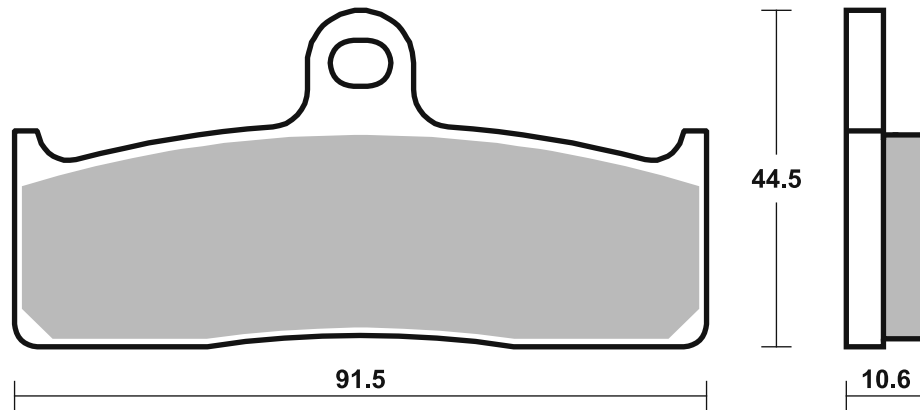

Available compounds

SI • RSI

SBS 866

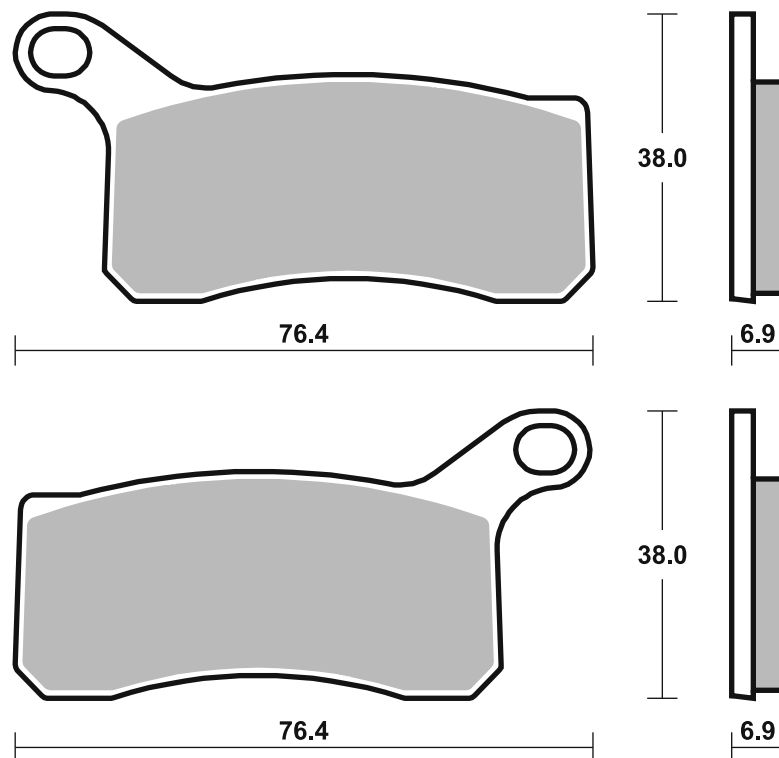



Available compounds

SI • RSI

SBS 867

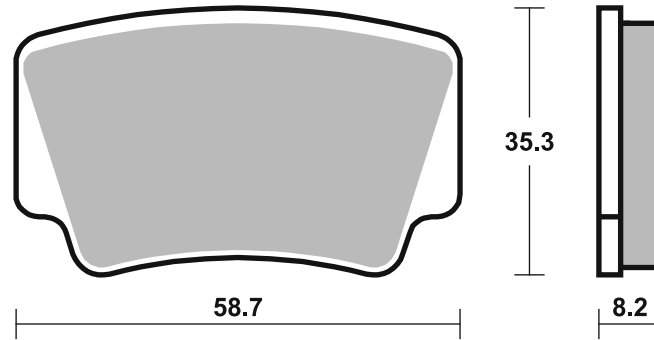

Available compounds

HS

SBS 869

1 set = 4 pcs.

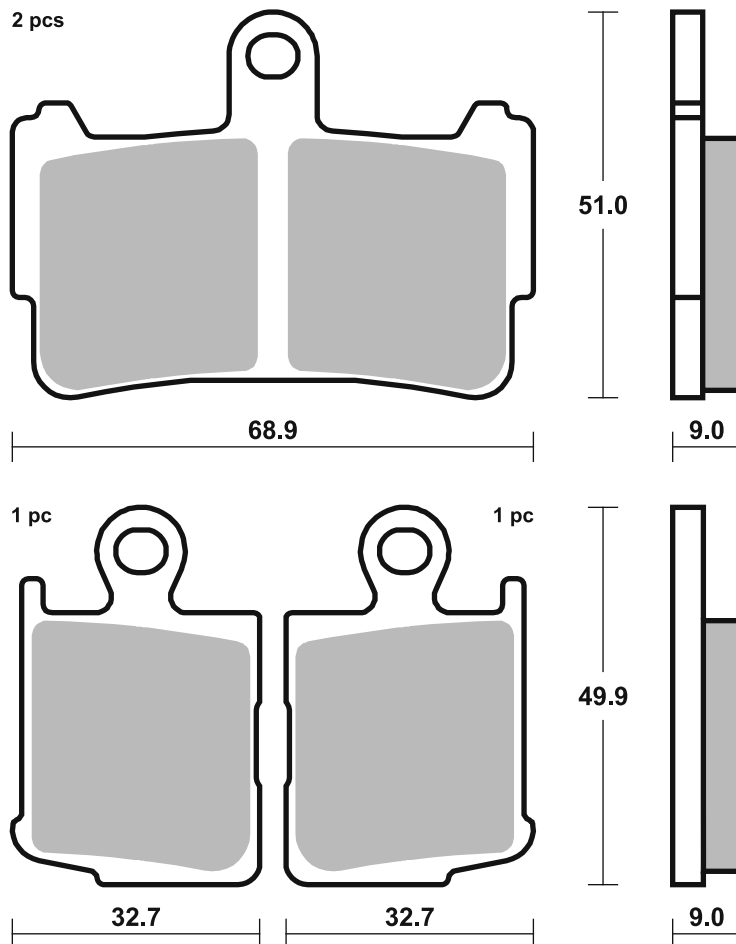

**Applications**

**SBS 870**

**Recommended compound**



<b>BMW</b>			
S	1000 R	13 - 19	HS
S	1000 RR	09 - 18	HS
S	1000 RR ABS	09 - 18	HS

**SBS 872**

**Recommended compound**



<b>HUSQVARNA</b>			
CR	65	12 - 13	RSI
TC	85	14 - 20	RSI
<b>KTM</b>			
	Freeride Electric	12 - 14	RSI
E-SM	Freeride	15 - 16	RSI
E-SX	Freeride	15 - 16	RSI
E-XC	Freeride	15 - 23	RSI
SX	85 (17/14)	11 - 20	RSI
SX	85 (19/16)	13 - 20	RSI
	250 Freeride R	14 - 19	RSI
	350 Freeride	12 - 17	RSI
<b>OHVALE</b>			
GP-0	110	17 - 23	RQ
GP-0	160	17 - 23	RQ
GP-0	190	17 - 23	RQ
GP-0	212	17 - 19	RST RQ

STREET  
AMERICAN  
SCOOTER

HF • HS • LS  
H.HF • H.CT • H.HS • H.LS  
HF • CT • MS

RACING  
OFF ROAD  
ATV

RST • DC • DCC • DS-1 • DS-2 • RQ  
SI • RSI • CS  
ATS • SI • RSI • PSI

Drawings 1:1

Available compounds

HS • DC • RST • DS-1 • DS-2

SBS 870

1 set = 4 pcs.

HS - Th. 8.0

RST / DC / DS-1 / DS-2 - Th. 8.7

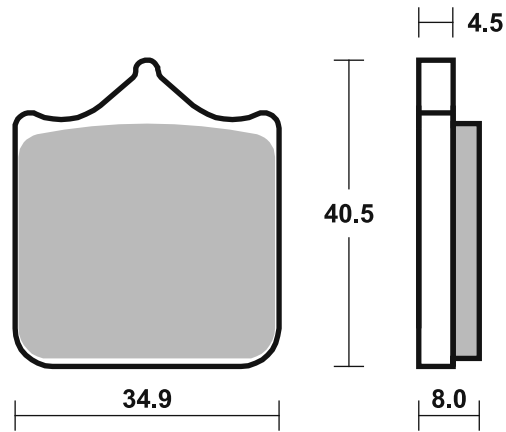

Available compounds

RST • RQ • CS • SI • RSI

SBS 872

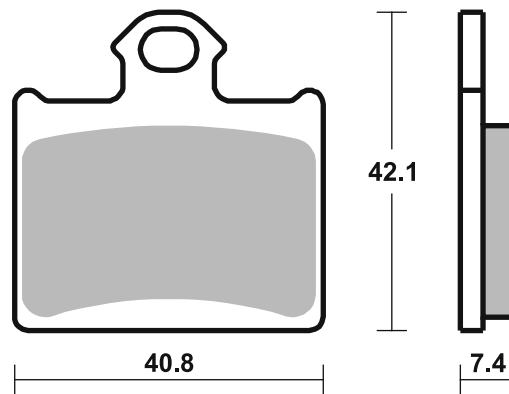

Brake Pad 1:1 Drawings,  
Compounds, Fitments

## Applications

### SBS 873

### Recommended compound



#### MALAGUTI

	125 Dune	19 - 23	HF
	125 Dune X	19 - 23	HF
	125 Monte Pro	19 - 23	HF
XSM	125	19 - 23	HF
XTM	125	19 - 23	HF

#### SWM

	125 Ace of Spades	20 - 20	HF
	125 Gran Milano		
	Outlaw	20 - 20	HF
	125 Outlaw	20 - 20	HF
	125 Varez	20 - 20	HF
RS	125 R	18 - 20	HF
SM	125 R	18 - 20	HF

### SBS 877

### Recommended compound



#### APRILIA

RS	457	24 - 24	HS
----	-----	---------	----

#### BMW

G	310 GS	17 - 24	HS
G	310 R	16 - 24	HS

#### FANTIC

	125 Caballero Deluxe	23 - 23	HF
	125 Caballero Flat		
	Track	17 - 23	HS
	125 Caballero Rally	22 - 23	HS
	125 Caballero		
	Scrambler	22 - 23	HS
	500 Caballero		
	Anniversary	23 - 23	HS
	500 Caballero Deluxe	23 - 23	HS
	500 Caballero Explorer	22 - 23	HS
	500 Caballero Flat		
	Track	23 - 23	HS
	500 Caballero Rally	22 - 23	HS
	500 Caballero		
	Scrambler	22 - 23	HS
	500 Caballero Six Days	22 - 22	HS

#### HUSQVARNA

	125 Svartpilen	21 - 23	HS
	401 Svartpilen	17 - 23	HS
	401 Vitpilen	17 - 23	HS

#### KTM

	125 Duke	11 - 19	HS
--	----------	---------	----

#### KTM

RC	125	14 - 22	HS
	200 Duke	12 - 17	HS
RC	200	14 - 22	HS
	250 Duke	14 - 15	HS
RC	250	14 - 15	HS
	390 Adventure	20 - 23	HS
	390 Adventure SW	23 - 23	HS
	390 Duke	13 - 23	HS
RC	390	14 - 23	HS

#### TRIUMPH

	400 Scrambler X	24 - 24	HS
	400 Speed	24 - 24	HS

STREET  
AMERICAN  
SCOOTER

HF • HS • LS  
H.HF • H.CT • H.HS • H.LS  
HF • CT • MS

RACING  
OFF ROAD  
ATV

RST • DC • DCC • DS-1 • DS-2 • RQ  
SI • RSI • CS  
ATS • SI • RSI • PSI

Drawings 1:1

Available compounds

HF

SBS 873

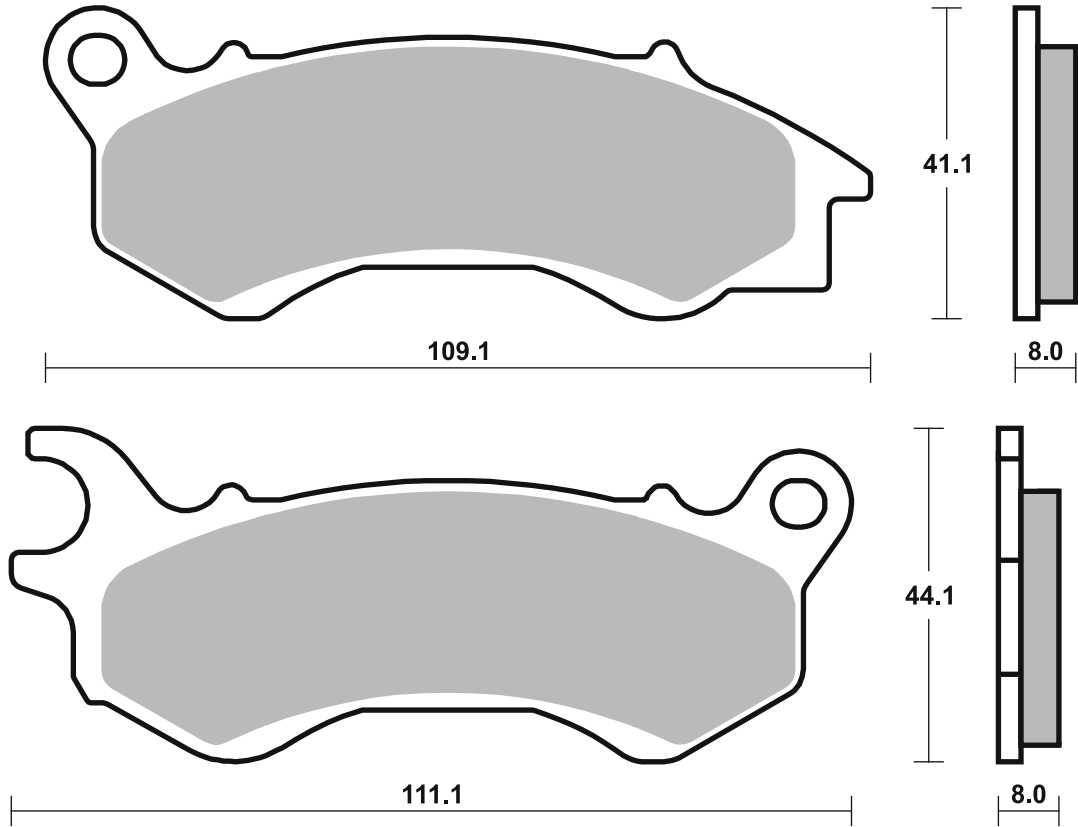

Available compounds

HF • HS • DC • RST

SBS 877

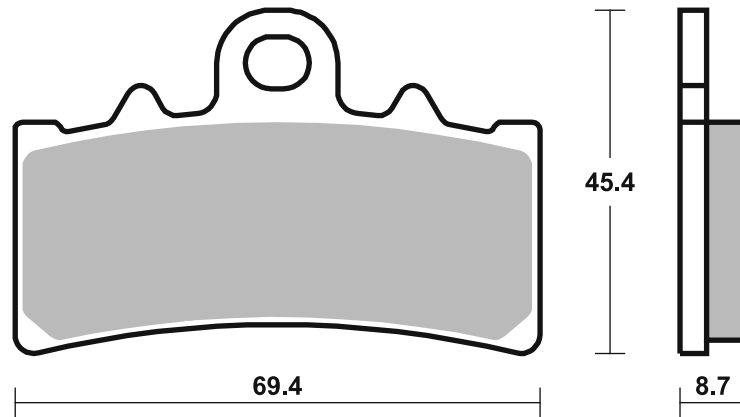

**SBS 878** Recommended compound



<b>CECTEK</b>			
	500 EFI King Cobra	09 - 13	<b>HF</b>
	500 EFI Quadrift	09 - 11	<b>HF</b>
	500 i Estoc	10 - 10	<b>HF</b>
<b>PGO</b>			
	500 Bug	08 - 14	<b>HF</b>
BR	500 i Racer	07 - 08	<b>HF</b>

**SBS 879** Recommended compound



<b>APRILIA</b>			
NA	850 Mana GT, ABS		
	(Parking Brake)	09 - 13	<b>HF</b>
<b>HONDA</b>			
CTX	700 D ABS w/DCT		
	(Parking Brake)	13 - 15	<b>HF</b>
CTX	700 ND ABS w/DCT		
	(Parking Brake)	14 - 15	<b>HF</b>
NC	700 D Integra w/DCT		
	(Parking Brake)	12 - 13	<b>HF</b>
NC	700 SD ABS w/DCT		
	(Parking Brake)	12 - 13	<b>HF</b>
NC	700 XD ABS w/DCT		
	(Parking Brake)	12 - 13	<b>HF</b>
NC	750 S w/DCT		
	(Parking Brake)	14 - 21	<b>HF</b>
NC	750 X w/DCT		
	(Parking Brake)	14 - 19	<b>HF</b>
NM4	750 Vultus ABS		
	w/DCT		
	(Parking Brake)	15 - 18	<b>HF</b>
CRF	1000 L Africa Twin		
	(Parking Brake)	16 - 19	<b>HF</b>
CRF	1000 L Africa Twin		
	Adventure Sports		
	(Parking Brake)	18 - 19	<b>HF</b>
VFR	1200 F w/DCT		
	(Parking Brake)	10 - 19	<b>HF</b>
VFR	1200 XDC Crosstourer		
	w/DCT		
	(Parking Brake)	12 - 19	<b>HF</b>



<b>HONDA</b>			
GL	1800 Gold Wing		
	(Parking Brake)	18 - 24	<b>HF</b>

Brake Pad 1:1 Drawings, Compounds, Fitments



STREET  
AMERICAN  
SCOOTER

HF • HS • LS  
H.HF • H.CT • H.HS • H.LS  
HF • CT • MS

RACING  
OFF ROAD  
ATV

RST • DC • DCC • DS-1 • DS-2 • RQ  
SI • RSI • CS  
ATS • SI • RSI • PSI

Drawings 1:1

Available compounds

HF • SI • RSI

SBS 878

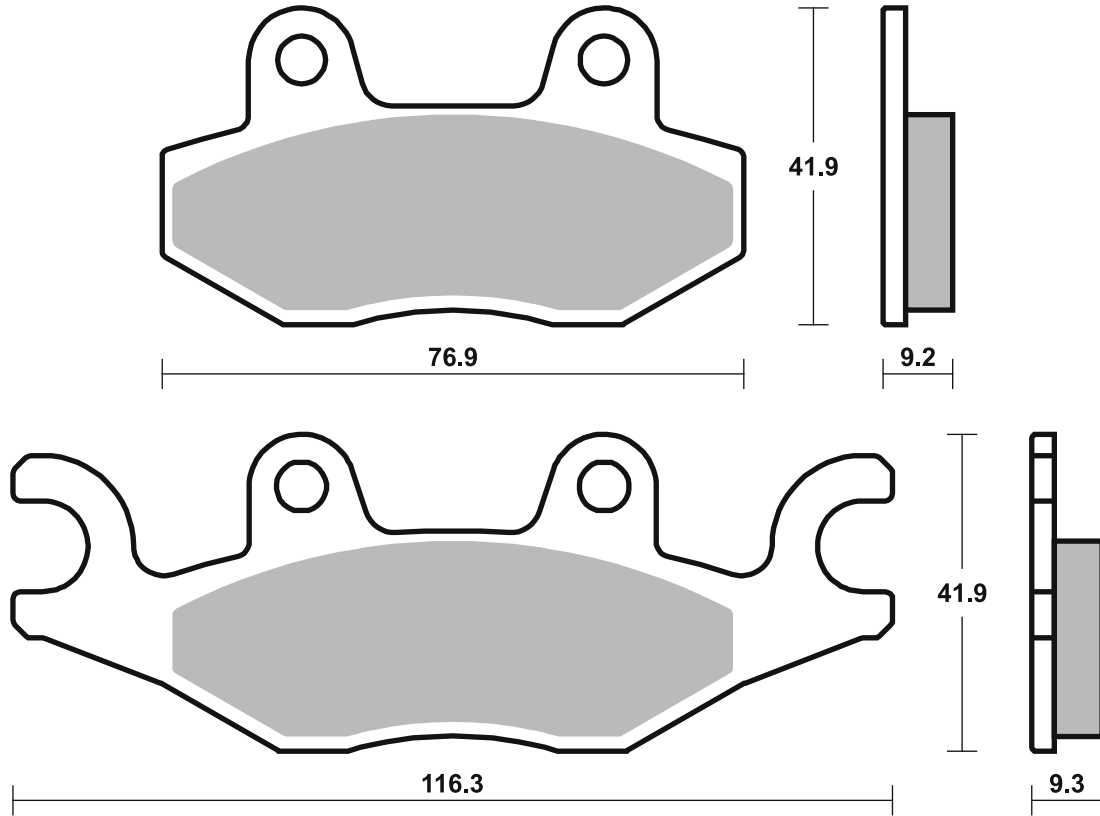

Available compounds

HF

SBS 879

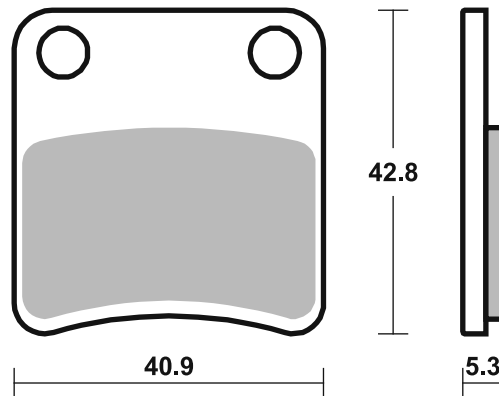

## Applications

### SBS 880

### Recommended compound



<b>HONDA</b>			
GL	1800 Gold Wing	01 - 17	LS
GL	1800 Gold Wing F6B	13 - 16	LS

### SBS 881

### Recommended compound



<b>HONDA</b>			
CBR	250 R (Nissin cal)	11 - 13	LS
CBR	250 R ABS (Nissin cal)	11 - 13	LS
CBR	250 RR	17 - 21	LS
CBR	300 F	14 - 16	LS
CBR	300 F ABS	14 - 17	LS
CBR	300 R	14 - 23	LS
CMX	300 Rebel	17 - 18	LS
CB	500 F	13 - 24	LS
CB	500 Hornet	24 - 24	LS
CB	500 X	13 - 24	LS
CBR	500 R	13 - 24	LS
CL	500	23 - 24	LS
CMX	500 Rebel	17 - 23	LS
CMX	500 Rebel S	20 - 20	LS
SCL	500	23 - 24	LS
CB	650 F	14 - 19	LS
CB	650 R Neo Sports Cafe	19 - 21	LS
CBR	650 F	14 - 20	LS
CBR	650 F ABS	14 - 20	LS
CBR	650 R	19 - 24	LS
CTX	700	14 - 18	LS
CTX	700 D ABS w/DCT	13 - 15	LS
CTX	700 N	14 - 18	LS
CTX	700 ND ABS w/DCT	14 - 15	LS
CB	750 Hornet	23 - 24	LS
NC	750 S w/DCT	14 - 21	LS
NC	750 X w/DCT	14 - 19	LS
NC	750 XAE	14 - 19	LS
NM4	750 Vultus ABS w/DCT	15 - 18	LS
CB	1000 Hornet	24 - 24	LS
CMX	1100 Rebel	21 - 22	LS



<b>KAWASAKI</b>			
KLE	650 Versys	15 - 15	LS
KLE	650 Versys ABS	15 - 15	LS
KLE	650 Versys LT	15 - 16	LS
Z	750 R	11 - 12	LS
Z	800	13 - 16	LS
Z	800 ABS	13 - 16	LS
Z	800 e	13 - 16	LS
Z	800 e ABS	13 - 16	LS
Z	900	17 - 24	LS
Z	900 Performance	22 - 23	LS
Z	900 SE	22 - 24	LS

<b>SUZUKI</b>			
GSX-R	250	17 - 23	HF
GW	250 Inazuma F	15 - 19	LS
SFV	650 Gladius	09 - 16	LS
SV	650	16 - 24	LS
SV	650 X	18 - 24	LS

Brake Pad 1:1 Drawings,  
Compounds, Fitments

STREET  
AMERICAN  
SCOOTER

HF • HS • LS  
H.HF • H.CT • H.HS • H.LS  
HF • CT • MS

RACING  
OFF ROAD  
ATV

RST • DC • DCC • DS-1 • DS-2 • RQ  
SI • RSI • CS  
ATS • SI • RSI • PSI

Drawings 1:1

Available compounds

LS

SBS 880

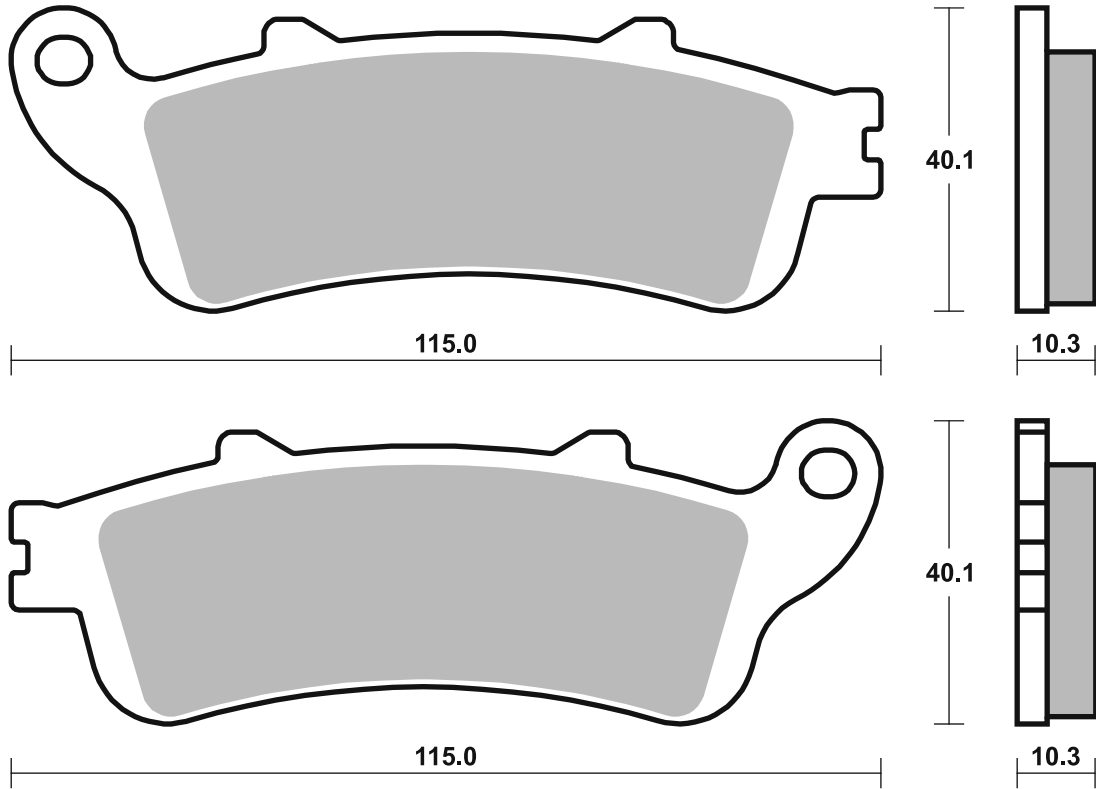

Available compounds

HF • LS • RQ

SBS 881

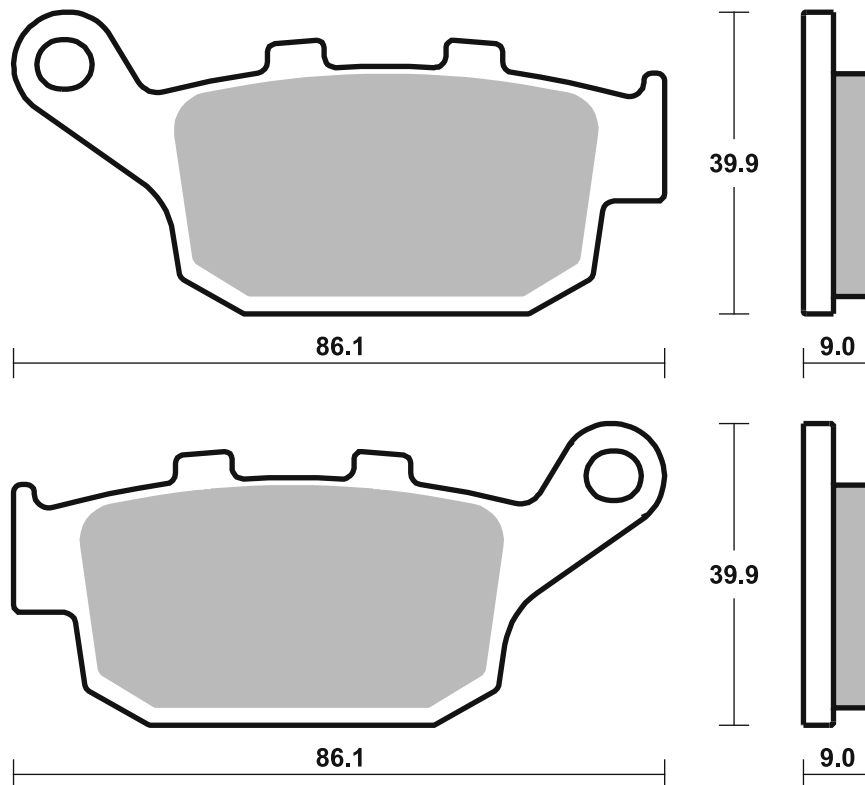

## Applications

### SBS 885

### Recommended compound



#### GASGAS

TXT	125 (Formula cal.)	12 - 13	<b>RSI</b>
TXT	250 (Formula cal.)	12 - 13	<b>RSI</b>
TXT	280 (Formula cal.)	12 - 12	<b>RSI</b>
TXT	300 (Formula cal.)	12 - 12	<b>RSI</b>

#### HUSQVARNA

TC	85	14 - 20	<b>RSI</b>
----	----	---------	------------

#### KTM

	Freeride Electric	12 - 14	<b>RSI</b>
E-SM	Freeride	15 - 16	<b>RSI</b>
E-SX	Freeride	15 - 16	<b>RSI</b>
E-XC	Freeride	15 - 23	<b>RSI</b>
SX	85 (17/14)	12 - 20	<b>RSI</b>
SX	85 (19/16)	13 - 20	<b>RSI</b>
	250 Freeride R	14 - 19	<b>RSI</b>
	350 Freeride	12 - 17	<b>RSI</b>

#### OHVALE

GP-0	110	17 - 23	<b>RST</b>
GP-0	160	17 - 23	<b>RST</b>
GP-0	190	17 - 23	<b>RST</b>

#### SHERCO

ST	80 (Formula cal.)	13 - 14	<b>RSI</b>
ST	125 (Formula cal.)	13 - 14	<b>RSI</b>
ST	250 (Formula cal.)	13 - 14	<b>RSI</b>
ST	290 (Formula cal.)	13 - 14	<b>RSI</b>
ST	305 (Formula cal.)	13 - 14	<b>RSI</b>

### SBS 886

### Recommended compound



#### KAWASAKI

VN	900 Classic	06 - 16	<b>LS</b>
VN	900 Classic SE	11 - 16	<b>LS</b>
VN	900 Custom	07 - 16	<b>LS</b>
VN	1500 Classic Fi	00 - 04	<b>LS</b>
VN	1500 Classic Tourer Fi	00 - 04	<b>LS</b>
VN	1500 Mean Streak	02 - 03	<b>LS</b>
VN	1600 Classic	03 - 08	<b>LS</b>
VN	1600 Mean Streak	04 - 05	<b>LS</b>
VN	1700 Classic	09 - 14	<b>LS</b>
VN	1700 Classic Tourer	09 - 14	<b>LS</b>
VN	1700 Voyager	09 - 16	<b>LS</b>
VN	2000	04 - 10	<b>LS</b>

#### SUZUKI

C	1500 T Intruder	13 - 18	<b>LS</b>
M	1500 Intruder	09 - 18	<b>LS</b>
M	1600 Intruder	05 - 07	<b>LS</b>
VZ	1600 Marauder	04 - 04	<b>LS</b>

STREET  
AMERICAN  
SCOOTER

HF • HS • LS  
H.HF • H.CT • H.HS • H.LS  
HF • CT • MS

RACING  
OFF ROAD  
ATV

RST • DC • DCC • DS-1 • DS-2 • RQ  
SI • RSI • CS  
ATS • SI • RSI • PSI

Drawings 1:1

Available compounds

RST • CS • SI • RSI

SBS 885

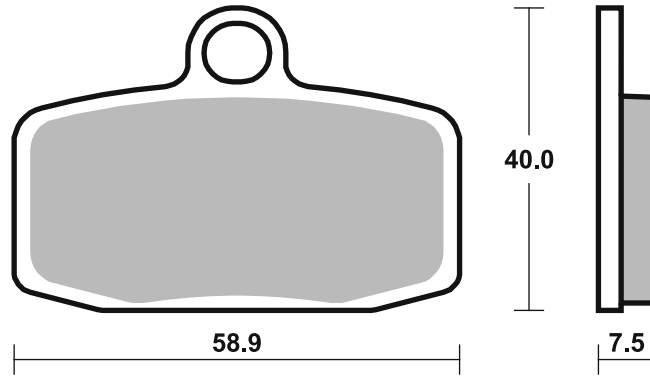

Available compounds

HF • LS

SBS 886

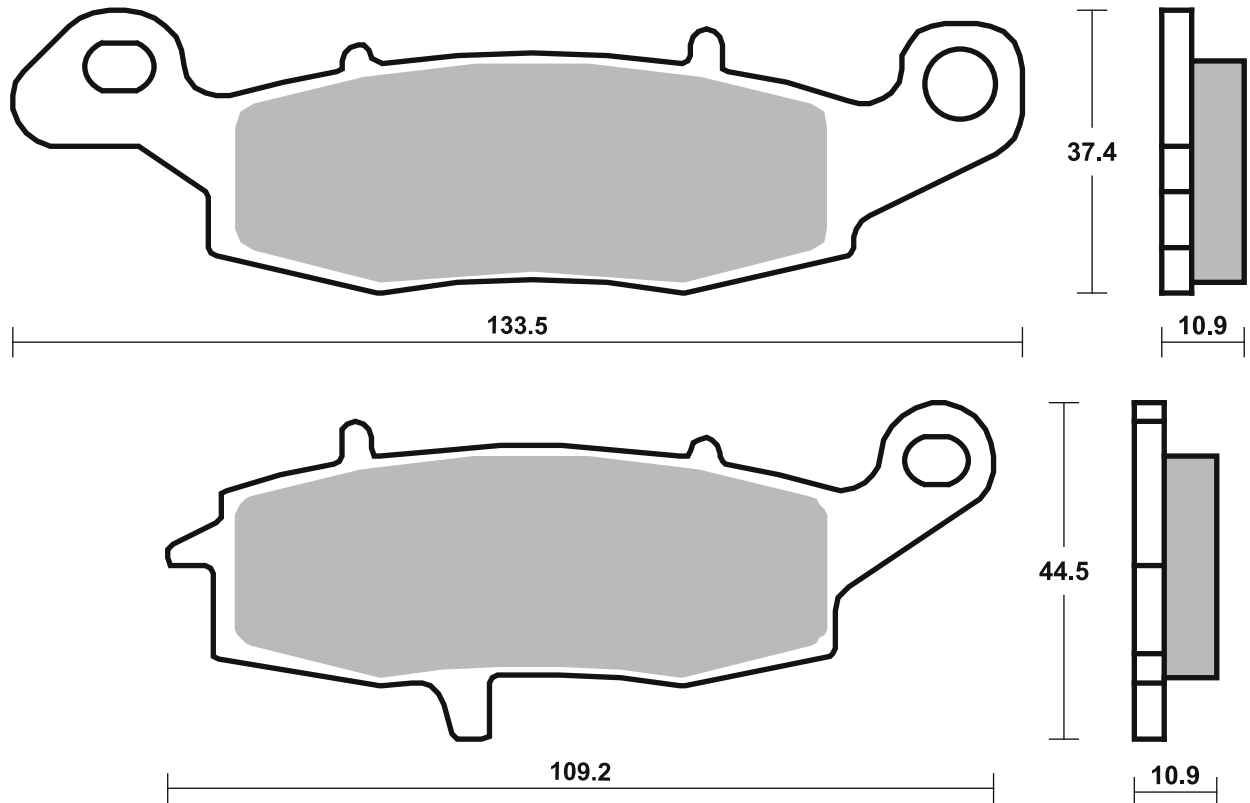

## Applications

### SBS 887

### Recommended compound



#### BREMBO RACING CALIPERS

Moto3/SBK XA88810/11, P2 34

Moto3/SBK XA88820/21, P2 34

#### GALESPEED

2 Piston Radial Front Caliper,

GSFCAR34F(Right)/GSFCAL34F(Left)

2 Piston Radial Front Caliper,

GSFCAR34T(Right)/GSFCAL34T(Left)

### SBS 889

### Recommended compound



#### BREMBO RACING CALIPERS

SBK Racing DX XB0.B1.31,

P4 30/34

SBK Racing SX XB0.B1.30,

P4 30/34

### SBS 892

### Recommended compound



#### HONDA

VFR 1200 F w/DCT 10 - 19

LS

VFR 1200 XC Crosstourer 12 - 19

LS

VFR 1200 XDC Crosstourer

w/DCT 12 - 19

LS

STREET  
AMERICAN  
SCOOTER

HF • HS • LS  
H.HF • H.CT • H.HS • H.LS  
HF • CT • MS

RACING  
OFF ROAD  
ATV

RST • DC • DCC • DS-1 • DS-2 • RQ  
SI • RSI • CS  
ATS • SI • RSI • PSI

Drawings 1:1

Available compounds

LS • DC • RST • DS-1 • DS-2 • RQ

SBS 887

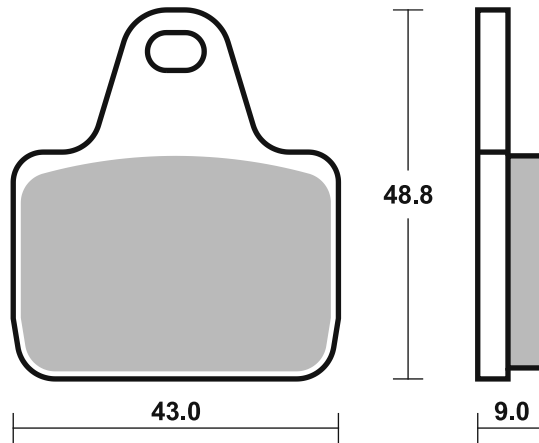

Available compounds

DS-1 • DS-2

SBS 889

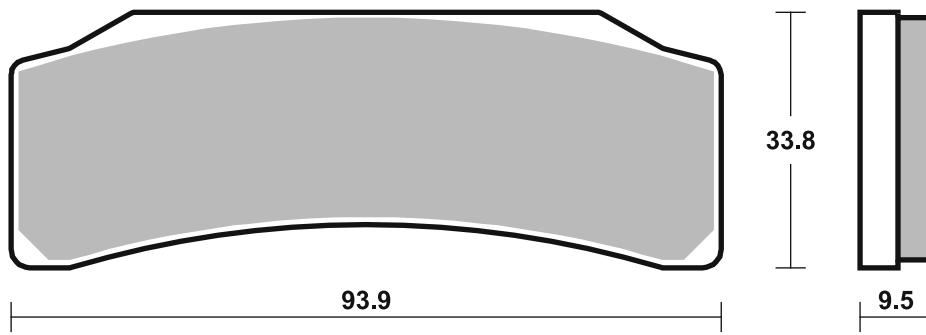

Available compounds

LS

SBS 892

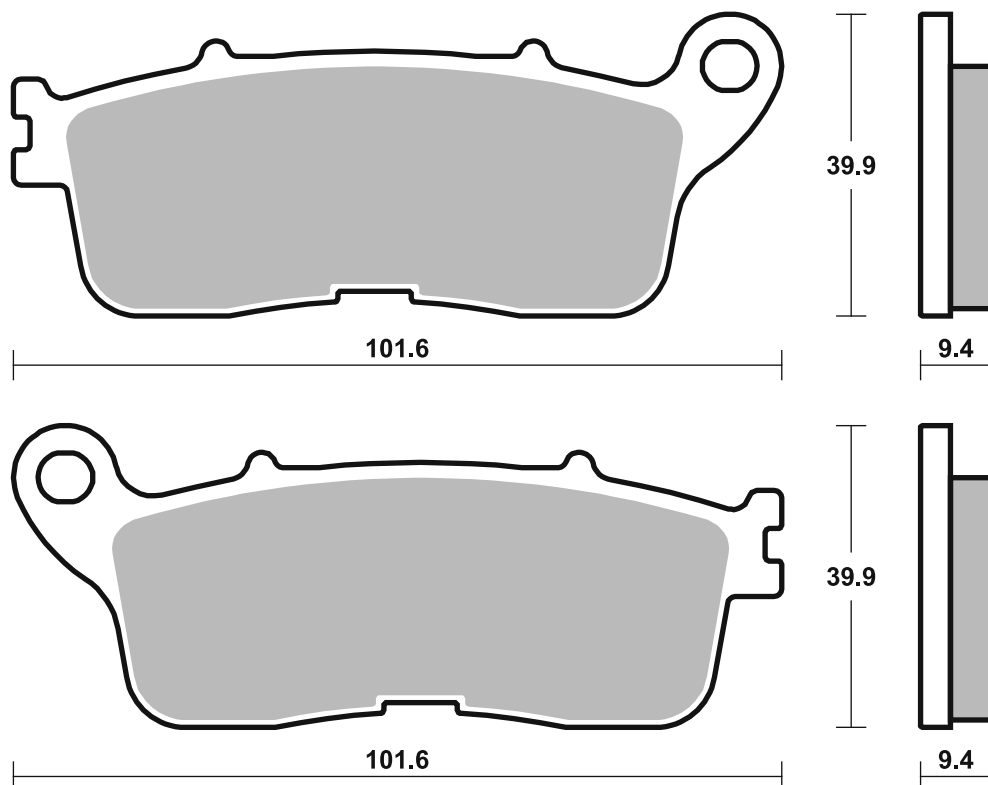

Applications

SBS 893 Recommended compound



SYM			
SN	250 Ni Wolf	14 - 15	HF
SN	250 T2 Wolf	12 - 15	HF
	300 Wolf Cafe Racer	15 - 15	HF
	300 Wolf Classic	15 - 15	HF
SB	300 Cafe Racer	16 - 17	HF

SBS 894 Recommended compound



KAWASAKI			
ZX-6R	636 Ninja	13 - 18	HS
ZX-6R	636 Ninja ABS	13 - 24	HS

SBS 895 Recommended compound



BETA			
	125 EVO	09 - 14	RSI
	200 EVO	09 - 14	RSI
	250 EVO (2-T / 4-T)	09 - 14	RSI
	290 EVO	09 - 13	RSI
	300 EVO	09 - 15	RSI

Brake Pad 1:1 Drawings, Compounds, Fitments



STREET  
AMERICAN  
SCOOTER

HF • HS • LS  
H.HF • H.CT • H.HS • H.LS  
HF • CT • MS

RACING  
OFF ROAD  
ATV

RST • DC • DCC • DS-1 • DS-2 • RQ  
SI • RSI • CS  
ATS • SI • RSI • PSI

Drawings 1:1

Available compounds

HF • HS

SBS 893

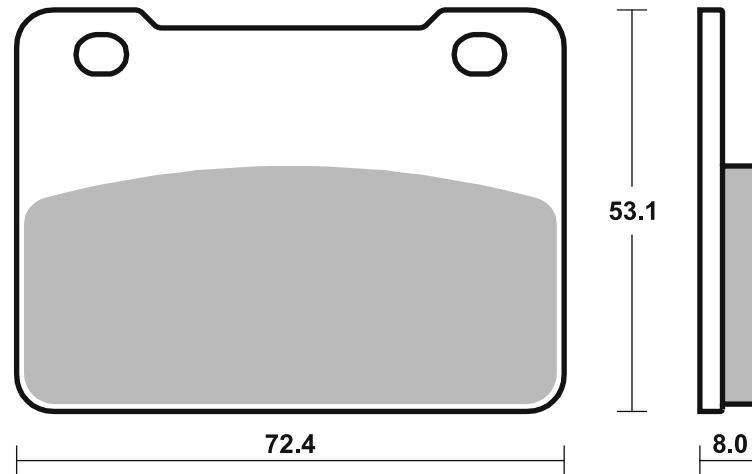

Available compounds

HS • DC • RST

SBS 894

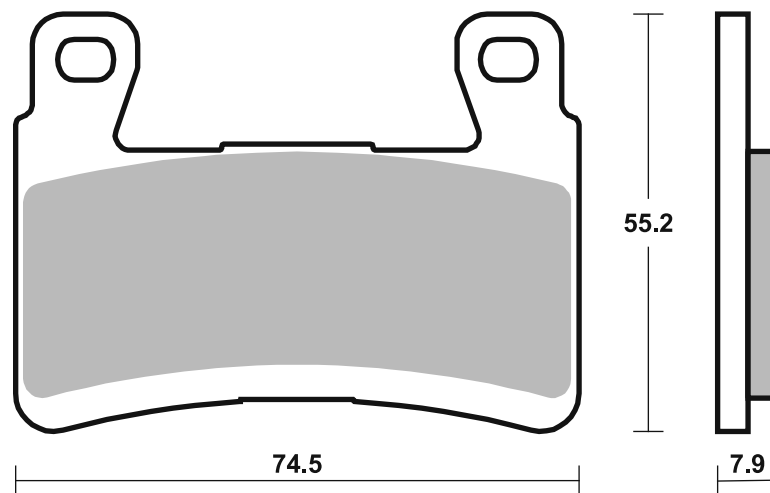

Available compounds

HF • RSI

SBS 895

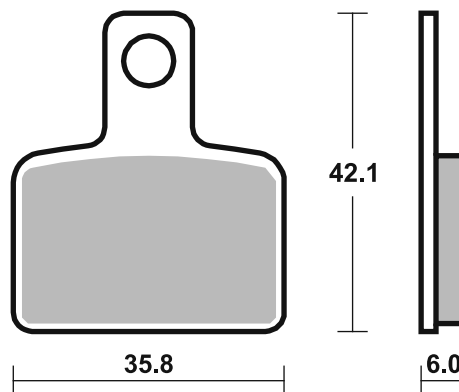

Brake Pad 1:1 Drawings,  
Compounds, Fitments

## Applications

### SBS 896

### Recommended compound



BETA		
80 Rev	08 - 10	RSI
125 Rev 3	06 - 08	RSI
200 Rev 3	06 - 08	RSI
250 4-T Rev 3	07 - 11	RSI
250 Rev 3	05 - 09	RSI
270 Rev 3	05 - 08	RSI

### SBS 897

### Recommended compound



POLARIS		
EV-LSV	10 - 11	ATS
LSV 4x4	11 - 12	ATS
Ranger 48v EV	13 - 18	ATS
500 Ranger 2x4	08 - 07	ATS
500 Ranger 2x4 EFI	08 - 13	ATS
500 Ranger 4x4	12 - 13	ATS
700 MVRS 4x4	08 - 08	ATS
700 Ranger 4x4 EFI	08 - 08	ATS
700 Ranger 6x6 EFI	12 - 13	ATS
800 MVRS 4x4	08 - 08	ATS
800 Ranger 4x4 EFI	10 - 10	ATS
800 Ranger 6x6 EFI	12 - 15	ATS
800 Ranger Crew	12 - 15	ATS
800 Ranger RZR4 EFI	12 - 14	ATS
800 Ranger XP	12 - 13	ATS
800 RZR-4	10 - 14	ATS
900 Ranger 4x4		
Diesel	10 - 14	ATS



POLARIS			
900 Ranger RZR4 XP			
EFI	12 - 15	ATS	ATS
900 Ranger RZR4 XP4			
EFI	12 - 14	ATS	ATS
925 RZR RS1	18 - 22	PSI	PSI
925 RZR Turbo XP4			
Turbo S	19 - 20	SI	
925 RZR XP Turbo	16 - 19	SI	
925 RZR XP4 Turbo	16 - 19	SI	
925 RZR XP4 Turbo S	19 - 20	SI	
925 RZR XP4 Turbo S			
Velocity	19 - 20	SI	
1000 General EPS	16 - 18	ATS	
1000 RZR XP	14 - 23	PSI	PSI
1000 RZR XP4	14 - 23	PSI	PSI
1050 MV Diesel Crew	13 - 18	ATS	ATS

### SBS 898

### Recommended compound



POLARIS		
450 Outlaw MXR	09 - 11	ATS
450 Outlaw S	08 - 08	ATS
525 Outlaw	07 - 13	ATS
525 Outlaw IRS	08 - 13	ATS
525 Outlaw S	08 - 11	ATS
570 RZR EFI	12 - 19	PSI
570 RZR Trail	20 - 22	PSI
800 Ranger RZR EFI	08 - 14	ATS
800 Ranger RZR S EFI	09 - 15	ATS
800 RZR	08 - 15	ATS
900 RZR Trail	20 - 20	PSI
900 RZR Trail S	20 - 22	PSI
900 RZR-S	15 - 20	PSI
RZR 900 50/55/60 Inch	15 - 20	PSI
1000 General EPS	16 - 18	ATS
1000 RZR Trail S	20 - 23	PSI
1000 RZR-S	16 - 20	PSI
RZR 1000 60 Inch	16 - 20	PSI

STREET  
AMERICAN  
SCOOTER

HF • HS • LS  
H.HF • H.CT • H.HS • H.LS  
HF • CT • MS

RACING  
OFF ROAD  
ATV

RST • DC • DCC • DS-1 • DS-2 • RQ  
SI • RSI • CS  
ATS • SI • RSI • PSI

Drawings 1:1

Available compounds

HF • RSI

SBS 896

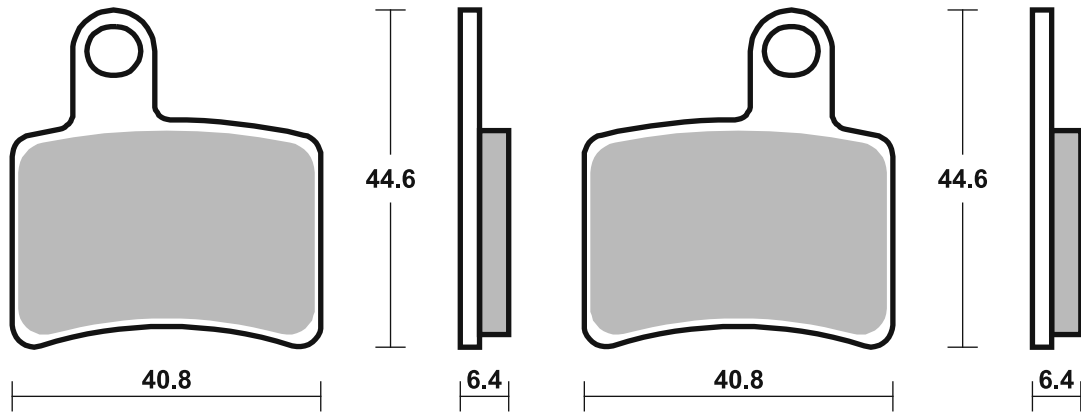

Available compounds

SI • RSI • ATS • PSI

SBS 897

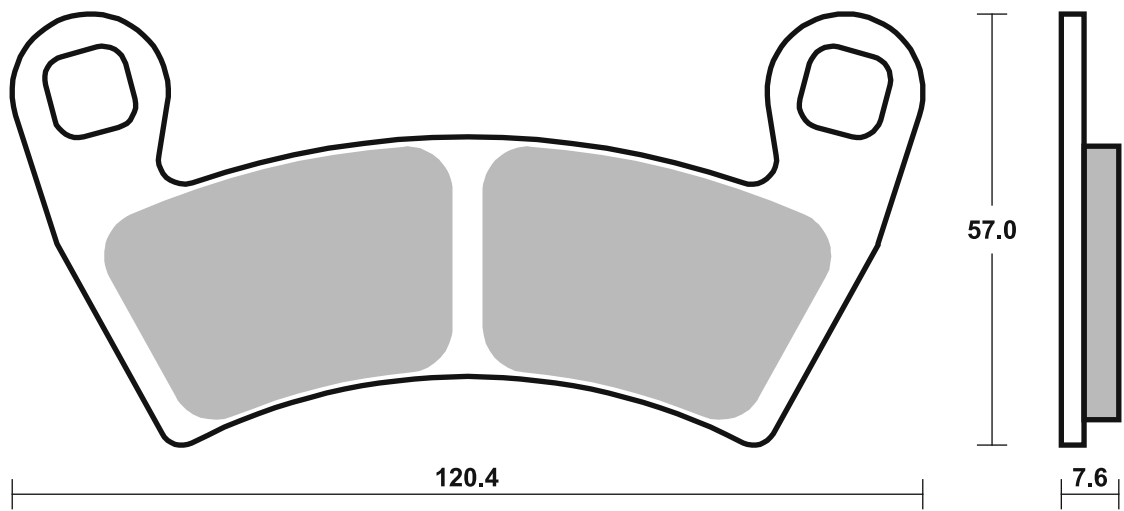

Available compounds

SI • RSI • ATS • PSI

SBS 898

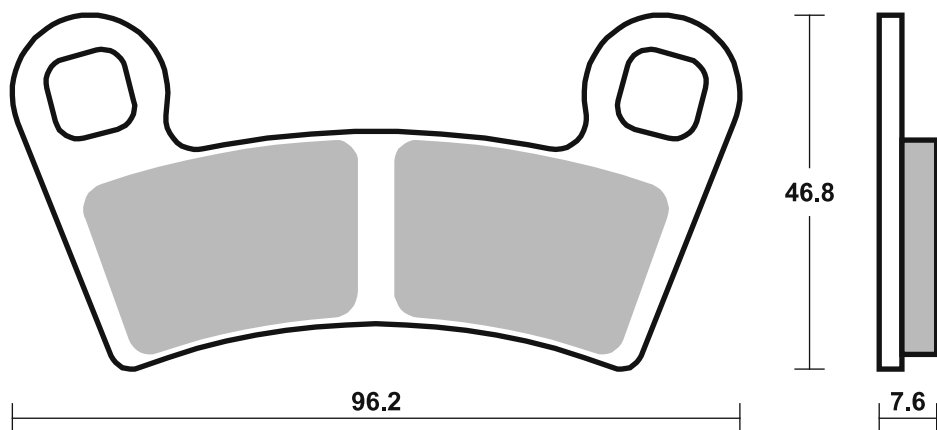

# Applications

## SBS 899

### Recommended compound



POLARIS			
500 Sportsman HO			
(from 16.12.2008)	09 - 14	ATS	ATS
550 Sportsman	11 - 14	ATS	ATS
550 Sportsman EPS	10 - 14	ATS	ATS
550 Sportsman EPS X2	14 - 14	ATS	ATS
550 Sportsman Touring			
EPS	10 - 12	ATS	ATS
550 Sportsman X2	10 - 14	ATS	ATS
550 Sportsman XP	09 - 12	ATS	ATS
550 Sportsman XP EPS	09 - 14	ATS	ATS
550 Sportsman XP			
Touring EPS	12 - 14	ATS	ATS
800 Sportsman			
(from 16.12.2008)	09 - 14	ATS	ATS
850 Forest	15 - 15	ATS	ATS
850 Scrambler	15 - 15	ATS	ATS
850 Scrambler HO EPS	13 - 15	ATS	ATS
850 Scrambler MD	15 - 15	ATS	ATS
850 Scrambler XP HO			
EPS	14 - 15	ATS	ATS
850 Sportsman	11 - 13	ATS	ATS
850 Sportsman MV	12 - 12	ATS	ATS
850 Sportsman Touring	14 - 15	ATS	ATS
850 Sportsman Touring			
EPS	10 - 13	ATS	ATS
850 Sportsman Touring			
HO EPS	13 - 14	ATS	ATS
850 Sportsman Touring			
MD	15 - 15	ATS	ATS
850 Sportsman X2	11 - 11	ATS	ATS
850 Sportsman XP	09 - 14	ATS	ATS



POLARIS			
850 Sportsman XP EPS	09 - 14	ATS	ATS
850 Sportsman XP HO			
EPS	13 - 14	ATS	ATS
850 Sportsman XP HO			
EPS MD	15 - 15	ATS	ATS
850 Sportsman XP			
Touring EPS	15 - 15	ATS	ATS
1000 Forest	15 - 15	ATS	ATS
1000 Scrambler MD	15 - 18	ATS	ATS
1000 Scrambler XP	15 - 18	ATS	ATS
1000 Scrambler XP HO			
EPS	14 - 14	ATS	ATS
1000 Sportsman MD	15 - 18	ATS	ATS
1000 Sportsman Touring	15 - 18	ATS	ATS
1000 Sportsman XP	15 - 18	ATS	ATS

## SBS 900

### Recommended compound



APRILIA			
660 Tuono Factory	22 - 23	HS	
660	20 - 22	HS	
RS 660 Extrem	23 - 23	HS	
RS 660 Trofeo	22 - 22	HS	
1000 Tuono	03 - 10	HS	
RSV 1000 Tuono V4 R	14 - 14	HS	
RSV 1100 Tuono V4	15 - 15	HS	
RSV 1100 Tuono V4 Factory	15 - 16	HS	
RSV 1100 Tuono V4 RR	15 - 16	HS	
1200 Caponord	13 - 19	HS	
1200 Caponord Rally	15 - 19	HS	
1200 Caponord Travel			
Pack	16 - 19	HS	

BENDA			
LFS 700	23 - 23	HS	
LFX 700	23 - 23	HS	

BENELLI			
500 Tornado	24 - 24	HS	
752 S	20 - 24	HS	
800 Leoncino	20 - 21	HS	
TRK 800	21 - 23	HS	

BMW			
F 800 R	15 - 18	HS	
F 900 R	20 - 24	HS	
F 900 XR	20 - 24	HS	
S 1000 XR	15 - 19	HS	
S 1000 XR	24 - 24	HS	
R 1200 GS	13 - 18	HS	



BMW			
R 1200 GS Adventure	14 - 18	HS	
R 1200 NineT	14 - 23	HS	
R 1200 R	15 - 18	HS	
R 1200 RS	14 - 18	HS	
R 1200 RT	14 - 18	HS	
R12 1200	24 - 24	HS	
R12 1200 NineT	24 - 24	HS	
R 1250 R	19 - 24	HS	
R 1250 RS	19 - 24	HS	

CAN-AM			
1330 Spyder F3	15 - 22	HS	
1330 Spyder F3			
Limited	16 - 22	HS	
1330 Spyder F3-S	15 - 22	HS	
1330 Spyder F3-T	16 - 22	HS	
1330 Spyder RS	14 - 16	HS	
1330 Spyder RS RSS	13 - 13	HS	
1330 Spyder RSS	14 - 15	HS	
1330 Spyder RSS			
Special Series	15 - 15	HS	
1330 Spyder RT	14 - 22	HS	
1330 Spyder RT Limited	13 - 22	HS	
1330 Spyder RT RTS	13 - 13	HS	
1330 Spyder RTS	14 - 15	HS	
1330 Spyder RTS			
Special Series	15 - 15	HS	
1330 Spyder ST	14 - 16	HS	
1330 Spyder ST Limited	13 - 15	HS	
1330 Spyder ST STS	13 - 13	HS	
1330 Spyder STS	14 - 15	HS	



CAN-AM			
1330 Spyder STS			
Special Series	15 - 15	HS	

CF MOTO			
400 SR S	24 - 24	HS	
SR 450	23 - 23	HS	

COLOVE			
322 321RR	23 - 23	HS	

DUCATI			
698 Hypermotard Mono	24 - 24	HS	
797 Monster	17 - 21	HS	
797 Monster+	17 - 20	HS	
803 Scrambler	17 - 18	HS	
803 Scrambler Classic	15 - 19	HS	
803 Scrambler CR	17 - 20	HS	
803 Scrambler CR			
Cafe Racer	17 - 20	HS	
803 Scrambler			
Desert Sled	17 - 23	HS	
803 Scrambler Enduro	15 - 16	HS	
803 Scrambler Flat			
Track Pro	16 - 16	HS	
803 Scrambler Full			
Throttle	15 - 24	HS	
803 Scrambler Icon	15 - 24	HS	
803 Scrambler Icon			
Dark	20 - 23	HS	
803 Scrambler Mach			
2.0	18 - 18	HS	

STREET  
AMERICAN  
SCOOTER

HF • HS • LS  
H.HF • H.CT • H.HS • H.LS  
HF • CT • MS

RACING  
OFF ROAD  
ATV

RST • DC • DCC • DS-1 • DS-2 • RQ  
SI • RSI • CS  
ATS • SI • RSI • PSI

Drawings 1:1

Available compounds

SI • RSI • ATS

SBS 899

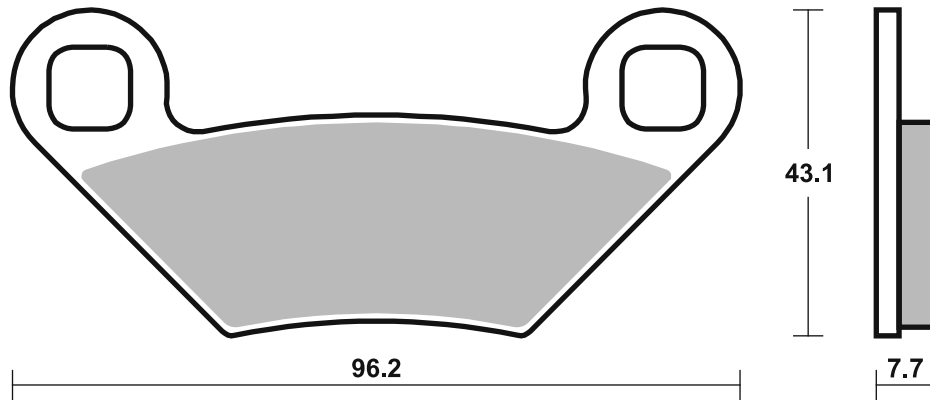

Available compounds

HS • DC • RST • DS-1 • DS-2 • H.HS

SBS 900

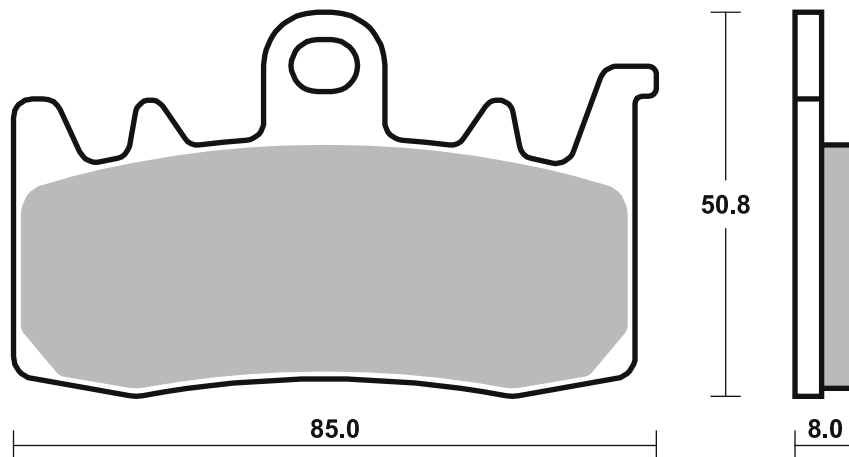



DUCATI			
803 Scrambler			
Nightshift	20 - 24	HS	
803 Scrambler SCR	20 - 20	HS	
803 Scrambler Street			
Classic	17 - 18	HS	
803 Scrambler Urban			
Enduro	15 - 18	HS	
803 Scrambler Urban			
Motard	22 - 23	HS	
821 Hypermotard	13 - 16	HS	
821 Hypermotard ABS	13 - 16	HS	
821 Hypermotard SP	13 - 16	HS	
821 Hypermotard SP			
ABS	13 - 16	HS	
821 Hyperstrada	13 - 16	HS	
821 Hyperstrada ABS	13 - 16	HS	
821 Monster	14 - 21	HS	
821 Monster Dark	15 - 16	HS	
821 Monster Stealth	19 - 21	HS	
899 Panigale	14 - 15	HS	
937 Monster	20 - 24	HS	
937 Monster +	20 - 24	HS	
937 Multistrada V2	22 - 24	HS	
937 Multistrada V2 S	22 - 24	HS	
939 Hypermotard	16 - 18	HS	
939 Hypermotard SP	16 - 18	HS	
939 Hyperstrada	16 - 16	HS	
939 SuperSport	17 - 20	HS	
939 SuperSport S	17 - 20	HS	
950 Hypermotard	19 - 24	HS	
950 Hypermotard RVE	20 - 24	HS	
950 Hypermotard SP	19 - 24	HS	
950 Multistrada	17 - 21	HS	
950 Multistrada S	19 - 21	HS	
950 Supersport	20 - 24	HS	
950 Supersport S	20 - 24	HS	
955 Panigale V2	20 - 24	HS	
955 Panigale V2			
Bayliss	22 - 24	HS	
955 Streetfighter V2	22 - 24	HS	
959 Panigale	16 - 20	HS	
959 Panigale Corse	18 - 20	HS	
1100 Scrambler	18 - 19	HS	
1100 Scrambler Dark			
Pro	20 - 24	HS	
1100 Scrambler			
Desert X	20 - 20	HS	
1100 Scrambler Pro	20 - 23	HS	
1100 Scrambler Special	18 - 19	HS	
1100 Scrambler Sport	18 - 19	HS	
1100 Scrambler Sport			
Pro	20 - 24	HS	
1100 Scrambler Tribute			
Pro	22 - 24	HS	
1158 Multistrada V4	21 - 24	HS	
1200 Monster	14 - 21	HS	
1200 Multistrada	15 - 16	HS	
1200 Multistrada Enduro	16 - 18	HS	
1200 Multistrada Enduro			
Pro	18 - 18	HS	
1260 Diavel	19 - 22	HS	
1260 Multistrada Enduro	19 - 21	HS	
1262 Xdiavel Dark	24 - 24	HS	
FANTIC			
500 Caballero	17 - 17	HS	
GASGAS			
SM 700	23 - 23	HS	



HARLEY DAVIDSON			
Livewire	19 - 24	H.HS	
S2 Del Mar	24 - 24	H.HS	
S2 Del Mar LE	24 - 24	H.HS	
975 Bronx	20 - 21	H.HS	
RA 1250 Pan America	21 - 22	H.HS	
RA 1250 Pan America			
Special	21 - 22	H.HS	
RH 1250 Sportster S	21 - 23	H.HS	
INDIAN			
FTR 1200	19 - 23	H.HS	
FTR 1200 R carbon	21 - 23	H.HS	
FTR 1200 Rally	19 - 23	H.HS	
FTR 1200 S	19 - 23	H.HS	
FTR 1200 S RR	20 - 23	H.HS	
1768 Pursuit Dark Horse	22 - 23	H.HS	
1768 Pursuit Limited	22 - 23	H.HS	
1800 Challenger	20 - 23	H.HS	
1800 Challenger			
Dark Horse	20 - 23	H.HS	
1800 Challenger Limited	20 - 23	H.HS	
KAWASAKI			
Z 900 RS SE	22 - 24	HS	
Z 900 SE	22 - 24	HS	
Z 1000 H2	20 - 23	HS	
KOVE			
322 321RR	23 - 23	HS	
KTM			
690 SMC R	21 - 24	HS	
LIVEWIRE			
ONE	19 - 24	H.HS	
S2 Del Mar	24 - 24	H.HS	
S2 Del Mar LE	24 - 24	H.HS	
MOTO-GUZZI			
V100 1042 Mandello	22 - 23	HS	
V100 1042 S Mandello	23 - 23	HS	
V100 1042 Stelvio	24 - 24	HS	
MV AGUSTA			
800 Rivale	13 - 17	HS	
800 Stradale	15 - 16	HS	
800 Turismo Veloce	14 - 19	HS	
800 Turismo Veloce			
Lusso	14 - 20	HS	
800 Turismo Veloce			
Lusso Scs	18 - 21	HS	
800 Turismo Veloce RC	17 - 20	HS	
800 Turismo Veloce			
Rosso	20 - 21	HS	
NIU			
RQi	24 - 24	HS	
NORTON			
961 Commando Cafe			
Racer MKII	18 - 19	HS	
961 Commando Sport	18 - 19	HS	
961 Dominator Naked	17 - 19	HS	
QJ MOTOR			
SRT 550 X	23 - 23	HS	
SRK 600	23 - 23	HS	
SRK 600 RR	23 - 23	HS	
SVT 650	23 - 23	HS	
SVT 650 X	24 - 24	HS	



QJ MOTOR			
SRT 700 Standard E X	23 - 23	HS	
SRK 800 RR	24 - 24	HS	
SRT 800 Standard E X	23 - 23	HS	
SWM			
400 Varez	20 - 20	HS	
TRIUMPH			
765 Street Triple R	17 - 23	HS	
765 Street Triple R Low	17 - 23	HS	
1200 Tiger Explorer	16 - 17	HS	
1200 Tiger XCA	18 - 20	HS	
1200 Tiger XCG	18 - 20	HS	
1200 Tiger XR	18 - 19	HS	
1200 Tiger XRT	18 - 20	HS	
1200 Tiger XRX	18 - 20	HS	
1200 Tiger XRX Low	18 - 20	HS	
2500 Rocket 3 GT	19 - 23	HS	
2500 Rocket 3 R	19 - 23	HS	
VOGE			
525 Brivido RR	24 - 24	HS	

STREET  
AMERICAN  
SCOOTER

HF • HS • LS  
H.HF • H.CT • H.HS • H.LS  
HF • CT • MS

RACING  
OFF ROAD  
ATV

RST • DC • DCC • DS-1 • DS-2 • RQ  
SI • RSI • CS  
ATS • SI • RSI • PSI

Drawings 1:1

Available compounds

HS • DC • RST • DS-1 • DS-2 • H.HS

SBS 900

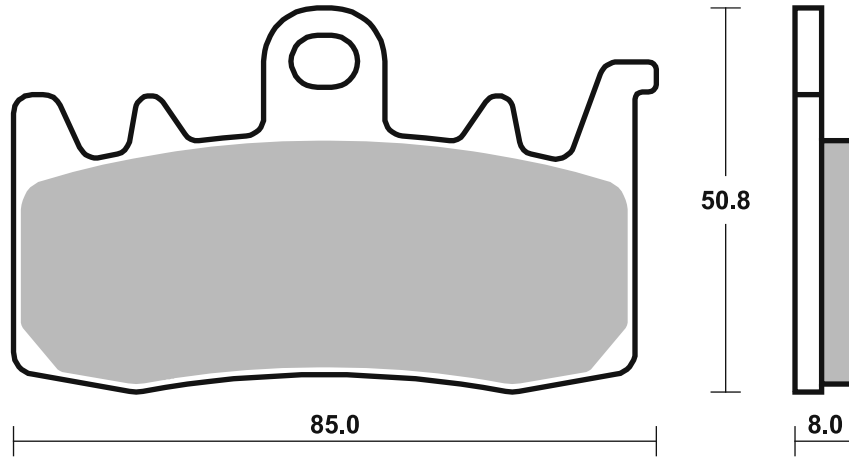

## Applications

## SBS 901

## Recommended compound



APRILIA			
RSV4-RF	1000	15 - 20	HS
RSV4-RR	1000	15 - 20	HS
RSV	1100 Tuono V4		
	Factory	17 - 18	HS
RSV	1100 Tuono V4 RR	17 - 19	HS

BIMOTA			
BB3	1000	14 - 18	HS
DB7	1099	09 - 09	HS
DB8	1198	10 - 14	HS
DB11	1200 VLX	13 - 13	HS

BMW			
S	1000 RR HP4	12 - 14	HS
	1200 HP2 Sport	08 - 10	HS

BREMBO RACING CALIPERS			
100 mm Radial GP4 RX 220B01020			
P4 32 (disc min. Th. 4,0mm)			
108 mm Radial GP4 RX 220B01020			
P4 32 (disc min. Th. 4,0mm)			
130 mm Radial GP4 RX 220B01020			
P4 32 (disc min. Th. 4,0mm)			

DUCATI			
	937 DesertX	23 - 24	HS
	937 DesertX Rally	24 - 24	HS
	937 Monster SP	23 - 24	HS
	1200 Diavel	11 - 18	HS
	1200 Diavel Carbon	14 - 23	HS
	1200 Diavel Dark	14 - 23	HS
	1200 Diavel Strada	11 - 14	HS
	1200 Diavel Titanium	15 - 23	HS
	1200 Xdiavel	16 - 18	HS
	1200 Xdiavel S	16 - 18	HS
	1260 Diavel		
	Lamborghini	20 - 23	HS
	1260 Diavel S	19 - 22	HS
	1262 Xdiavel	19 - 23	HS



DUCATI			
	1262 Xdiavel Black		
	Star	20 - 23	HS
	1262 Xdiavel Dark	22 - 23	HS
	1262 Xdiavel Nera	24 - 24	HS
	1262 Xdiavel S	19 - 24	HS

ENERGICA			
	Ego	15 - 21	HS
	Eva EsseEsse9	18 - 23	HS
	Eva Ribelle	15 - 21	HS
	Experia	23 - 23	HS

HONDA			
CBR	1000 RR SP	14 - 22	HS
CBR	1000 RR SP2	17 - 19	HS
CBR	1000 RR-R SP		
	Fireblade	20 - 21	HS
RC213V-S	1000	16 - 18	HS

KAWASAKI			
ZZR	1400 Performance		
	Sport	17 - 19	HS
ZZR	1400 SE	16 - 18	HS

KOVE			
MX	250 Supermoto	23 - 23	HS

KTM			
	890 Duke R	20 - 20	HS
	1290 Super Duke GT	16 - 20	HS

MOTO-MORINI			
	1200 Corsaro ZT	20 - 20	HS
	1200 Corsaro ZZ	18 - 20	HS
	1200 Milano	18 - 24	HS
	1200 Scrambler	18 - 18	HS
	1200 Super		
	Scrambler	20 - 20	HS



MV AGUSTA			
F3	675	15 - 20	HS
F3	675 RC	16 - 20	HS
	800 Superverloce	20 - 22	HS
F3	800	14 - 20	HS
F3	800 RC	16 - 20	HS

TRIUMPH			
	675 Daytona R Triple	11 - 18	HS
	765 Daytona Moto2	20 - 22	HS
	765 Street Triple RS	17 - 23	HS
	850 Tiger Sport	21 - 23	HS
	900 Rally Pro	20 - 23	HS
	900 Tiger	20 - 23	HS
	900 Tiger GT	20 - 23	HS
	900 Tiger GT Low	20 - 23	HS
	900 Tiger GT Pro	20 - 23	HS
	900 Tiger Rally	20 - 23	HS
	1050 Speed 94R	15 - 16	HS
	1050 Speed Triple	16 - 17	HS
	1050 Speed Triple R	12 - 18	HS
	1050 Speed Triple RS	16 - 20	HS
	1050 Speed Triple S	16 - 20	HS
	1200 Scrambler XC	19 - 23	HS
	1200 Scrambler XE	19 - 24	HS
	1200 Speed Triple RR	22 - 22	HS
	1200 Speed Triple RS	21 - 23	HS
	1200 Speed Twin	21 - 23	HS
	1200 Thruxton R	16 - 19	HS
	1200 Thruxton RS	20 - 23	HS
	1200 Tiger GT	22 - 23	HS
	1200 Tiger GT Explorer	22 - 23	HS
	1200 Tiger GT Pro	22 - 23	HS
	1200 Tiger Rally Explorer	22 - 23	HS
	1200 Tiger Rally Pro	22 - 23	HS

## SBS 904

## Recommended compound



HARLEY DAVIDSON			
FLHTCUTG	1690 Tri Glide Ultra		
	Classic Trike	09 - 13	H.LS
FLHXXX	1690 Street Glide		
	Trike	10 - 11	H.LS



STREET  
AMERICAN  
SCOOTER

HF • HS • LS  
H.HF • H.CT • H.HS • H.LS  
HF • CT • MS

RACING  
OFF ROAD  
ATV

RST • DC • DCC • DS-1 • DS-2 • RQ  
SI • RSI • CS  
ATS • SI • RSI • PSI

Drawings 1:1

Available compounds

HS • DC • RST • DS-1 • DS-2

SBS 901

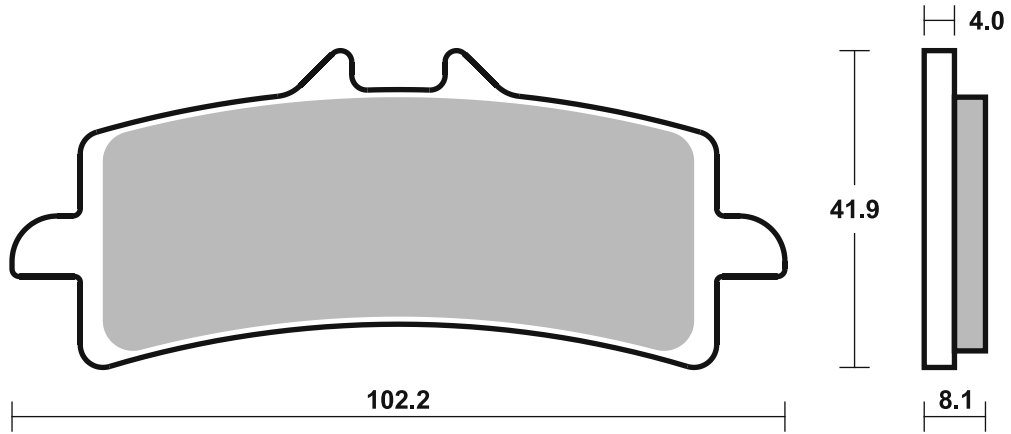

Available compounds

H.LS

SBS 904

1 set = 4 pcs.

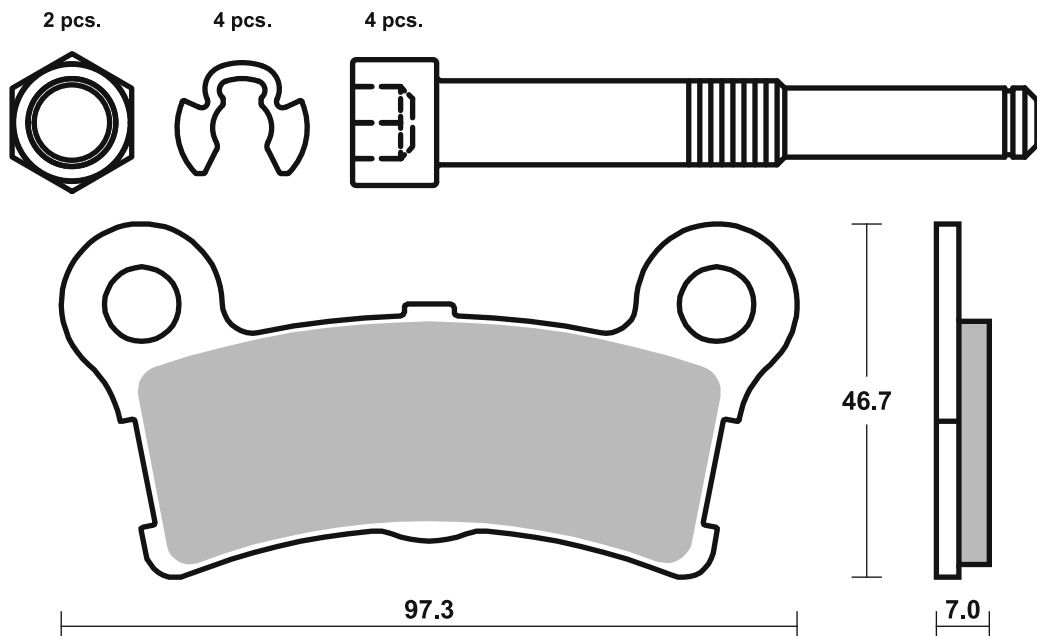



STREET  
AMERICAN  
SCOOTER

HF • HS • LS  
H.HF • H.CT • H.HS • H.LS  
HF • CT • MS

RACING  
OFF ROAD  
ATV

RST • DC • DCC • DS-1 • DS-2 • RQ  
SI • RSI • CS  
ATS • SI • RSI • PSI

Drawings 1:1

Available compounds

SI • RSI • ATS

SBS 905

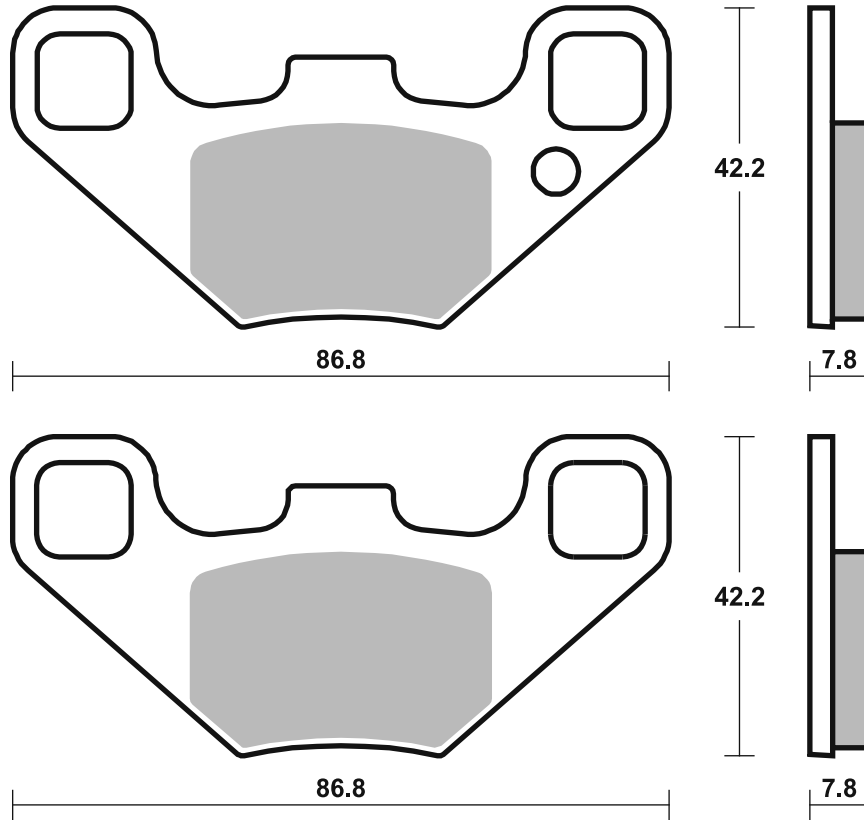

Available compounds

SI • RSI • ATS

SBS 906

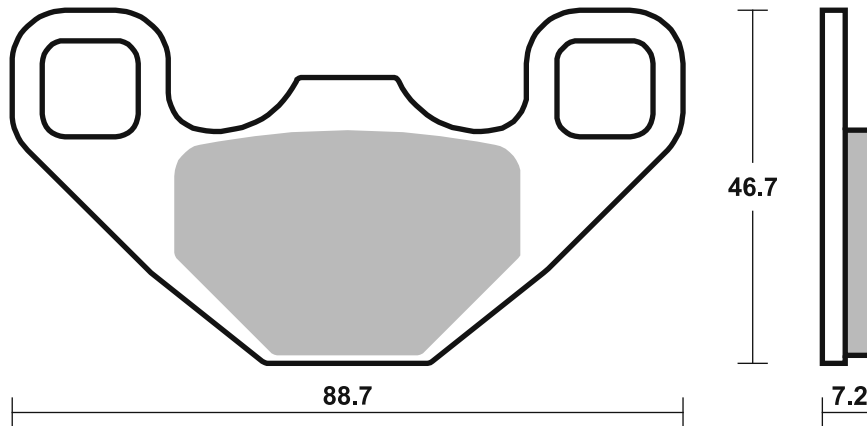

SBS 907

Recommended compound



CAN-AM

DS	450	08 - 12	SI	

SBS 908

Recommended compound



CAN-AM

DS	450	08 - 12	SI	
----	-----	---------	----	--

JOHN DEERE

HPX	350 Gator	10 - 14	SI	SI
-----	-----------	---------	----	----

Brake Pad 1:1 Drawings,  
Compounds, Fitments

STREET  
AMERICAN  
SCOOTER

HF • HS • LS  
H.HF • H.CT • H.HS • H.LS  
HF • CT • MS

RACING  
OFF ROAD  
ATV

RST • DC • DCC • DS-1 • DS-2 • RQ  
SI • RSI • CS  
ATS • SI • RSI • PSI

Available compounds

SI • RSI

SBS 907

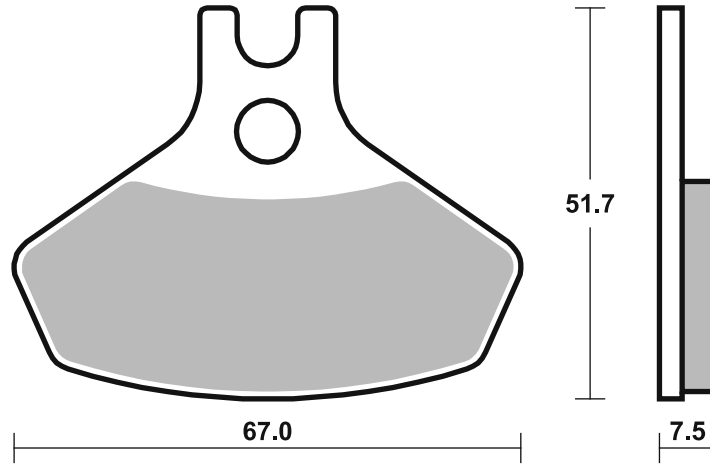

Available compounds

SI • RSI

SBS 908

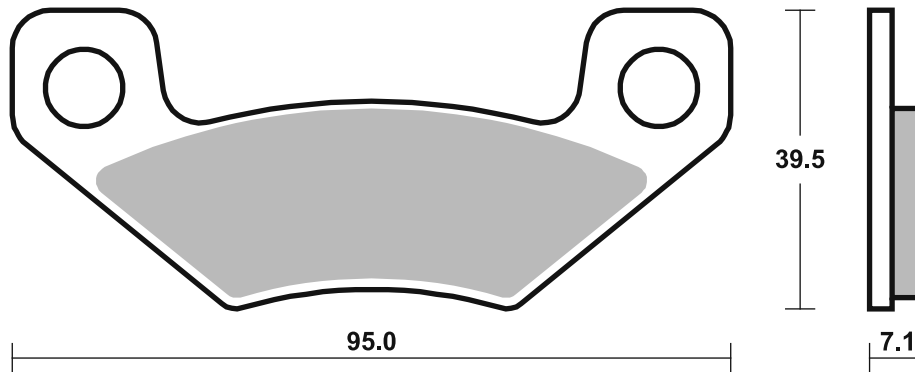



STREET  
AMERICAN  
SCOOTER

HF • HS • LS  
H.HF • H.CT • H.HS • H.LS  
HF • CT • MS

RACING  
OFF ROAD  
ATV

RST • DC • DCC • DS-1 • DS-2 • RQ  
SI • RSI • CS  
ATS • SI • RSI • PSI

Drawings 1:1

Available compounds

DS-1 • DS-2

SBS 909

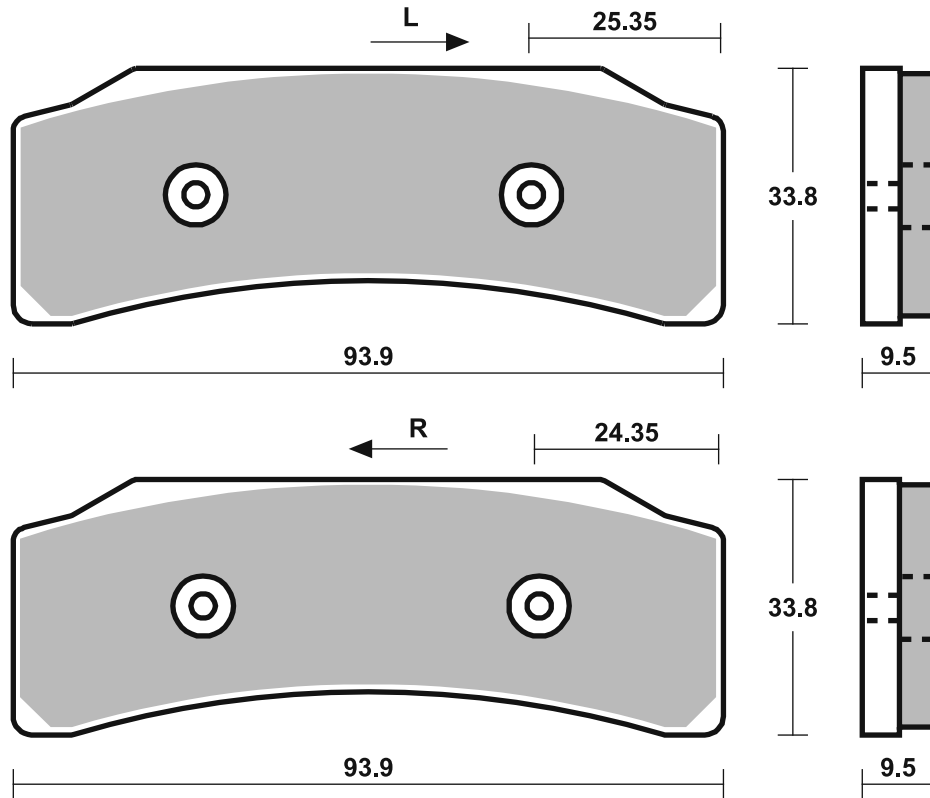

Available compounds

SI • RSI

SBS 910

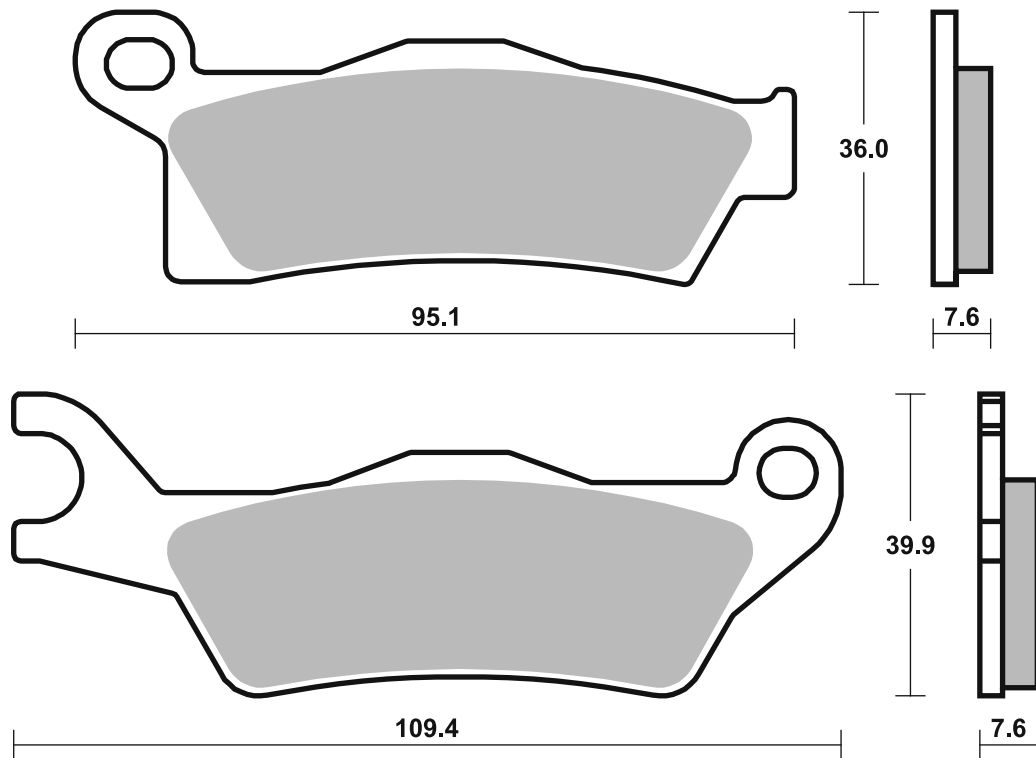

Dimensions in mm / Dimensions en mm  
1" = 25.4 mm, 1 mm = 0.04"

Brake Pad 1:1 Drawings,  
Compounds, Fitments

**Applications**

**SBS 911**

**Recommended compound**



<b>CAN-AM</b>				
450 Outlander	15 - 23	<b>SI</b>		
450 Outlander MAX	15 - 23	<b>SI</b>		
500 Outlander	13 - 16	<b>SI</b>		
500 Outlander MAX	13 - 16	<b>SI</b>		
500 Renegade	13 - 15	<b>SI</b>	<b>SI</b>	
650 Outlander	13 - 22	<b>SI</b>		
650 Outlander MAX	13 - 22	<b>SI</b>		
800 Outlander	12 - 15	<b>SI</b>		
800 Outlander MAX	13 - 14	<b>SI</b>		
800 Renegade	12 - 15	<b>SI</b>	<b>SI</b>	
1000 Outlander	13 - 23	<b>SI</b>		
1000 Outlander MAX	13 - 23	<b>SI</b>		
1000 Renegade	12 - 23	<b>SI</b>	<b>SI</b>	
1000 Renegade	20 - 23	<b>SI</b>		

**SBS 912**

**Recommended compound**



<b>ARCTIC CAT</b>				
1000 Wildcat 4X	16 - 18	<b>ATS</b>		
1000 Wildcat X	16 - 18	<b>ATS</b>		
1000 Wildcat X Ltd.	17 - 18	<b>ATS</b>		
1000 Wildcat X SE	17 - 18	<b>ATS</b>		
<b>JOHN DEERE</b>				
XUV 625 Gator	11 - 11	<b>ATS</b>		
XUV 825 Gator	11 - 11	<b>ATS</b>		
XUV 855 D Gator	11 - 11	<b>ATS</b>		

Brake Pad 1:1 Drawings, Compounds, Fitments



STREET  
AMERICAN  
SCOOTER

HF • HS • LS  
H.HF • H.CT • H.HS • H.LS  
HF • CT • MS

RACING  
OFF ROAD  
ATV

RST • DC • DCC • DS-1 • DS-2 • RQ  
SI • RSI • CS  
ATS • SI • RSI • PSI

Drawings 1:1

Available compounds

SI • RSI

SBS 911

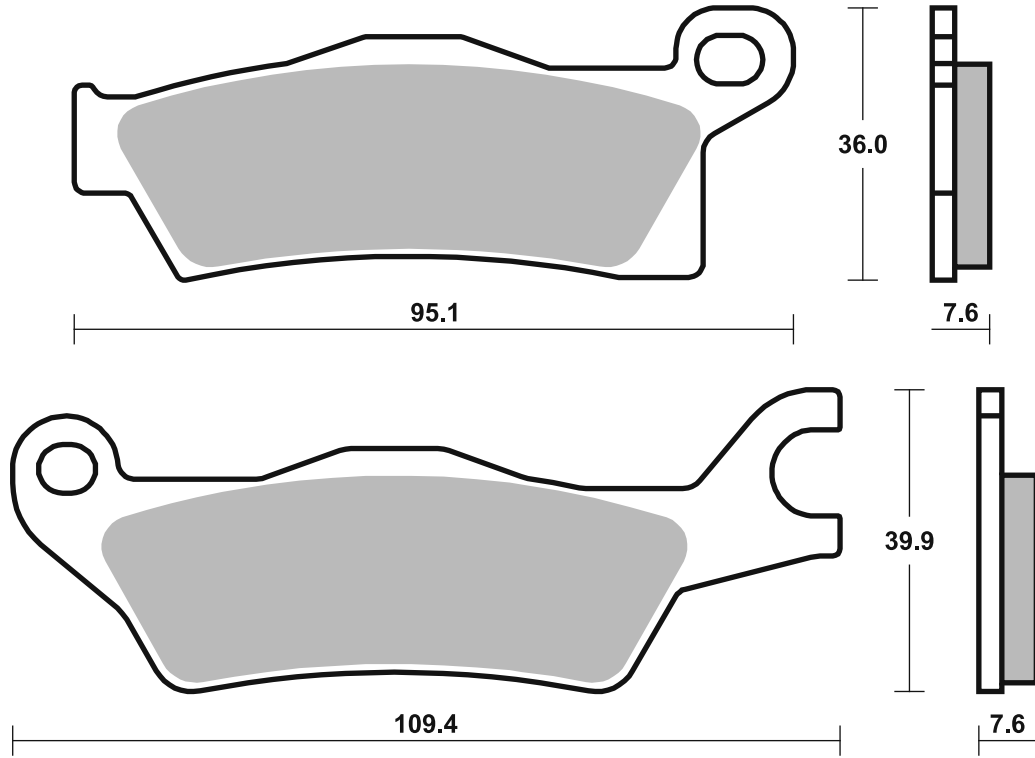

Available compounds

SI • RSI • ATS

SBS 912

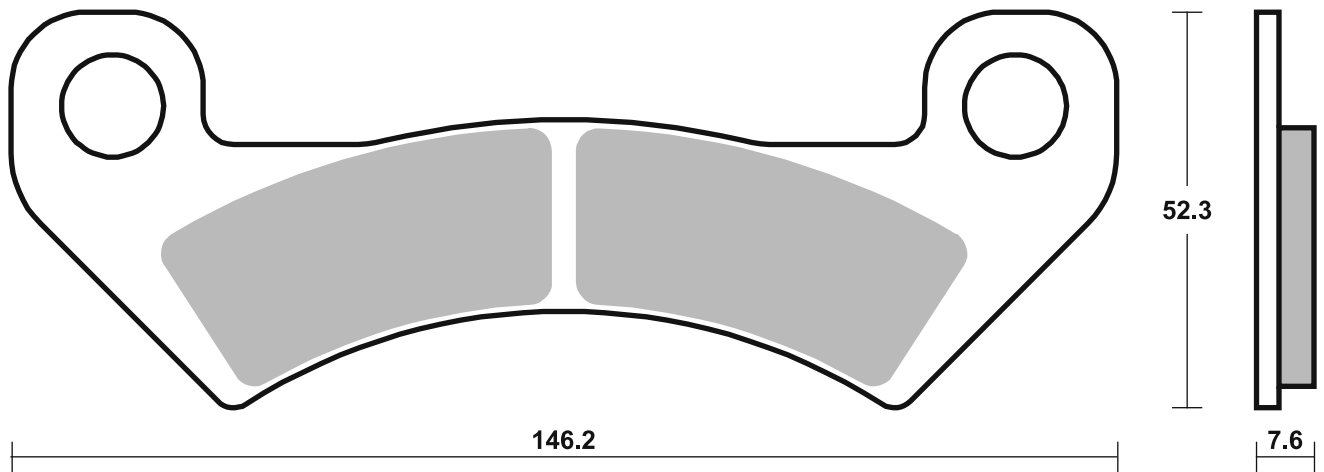

# Applications

## SBS 914 Recommended compound



<b>CF MOTO</b>			
	450 C-Force L	16 - 17	<b>SI</b>
	450 G-Force L	16 - 17	<b>SI</b>
CF	500 Terralander	13 - 15	<b>SI</b>
	550 C-Force	16 - 17	<b>SI</b>
CF	625 Terralander	11 - 15	<b>SI</b>
CF	800 Terralander	12 - 14	<b>SI</b>
<b>GOES</b>			
	360 Max	08 - 14	<b>SI</b>
	520 Max	07 - 12	<b>SI</b>
G	520	07 - 12	<b>SI</b>
G	525	12 - 14	<b>SI</b>
G	620	11 - 14	<b>SI</b>
G	625 A	12 - 14	<b>SI</b>

## SBS 915 Recommended compound



<b>BENELLI</b>			
TNT	125	18 - 19	<b>HF</b>
TNT	135	18 - 19	<b>HF</b>
<b>CF MOTO</b>			
	450 CL-C	24 - 24	<b>HF</b>
	450 NK	24 - 24	<b>HF</b>
SR	450	23 - 23	<b>HF</b>
<b>HONDA</b>			
CB	125 R	18 - 24	<b>HF</b>
CBR	125 R	11 - 18	<b>HF</b>
MSX	125	14 - 24	<b>HF</b>
CRF	250 L	13 - 15	<b>SI</b>
CRF	250 L ABS	17 - 21	<b>SI</b>
CRF	250 M	14 - 18	<b>SI</b>
CRF	250 Rally	17 - 19	<b>SI</b>
CB	300 R	18 - 24	<b>HF</b>
CB	300 R Neo Sports Cafe	19 - 19	<b>HF</b>
CRF	300 L	21 - 21	<b>SI</b>
CRF	300 Rally	21 - 21	<b>SI</b>
<b>SUZUKI</b>			
GSX-R	125 RL	17 - 24	<b>HF</b>
GSX-R	125 RLX	17 - 24	<b>HF</b>
GSX-S	125 ML	17 - 24	<b>HF</b>
GSX-S	125 MLX	17 - 24	<b>HF</b>
<b>VOGE</b>			
	125 Brivido R	24 - 24	<b>HF</b>
	350 Trofeo AC	24 - 24	<b>HF</b>

STREET  
AMERICAN  
SCOOTER

HF • HS • LS  
H.HF • H.CT • H.HS • H.LS  
HF • CT • MS

RACING  
OFF ROAD  
ATV

RST • DC • DCC • DS-1 • DS-2 • RQ  
SI • RSI • CS  
ATS • SI • RSI • PSI

Drawings 1:1

Available compounds

SI • RSI

SBS 914

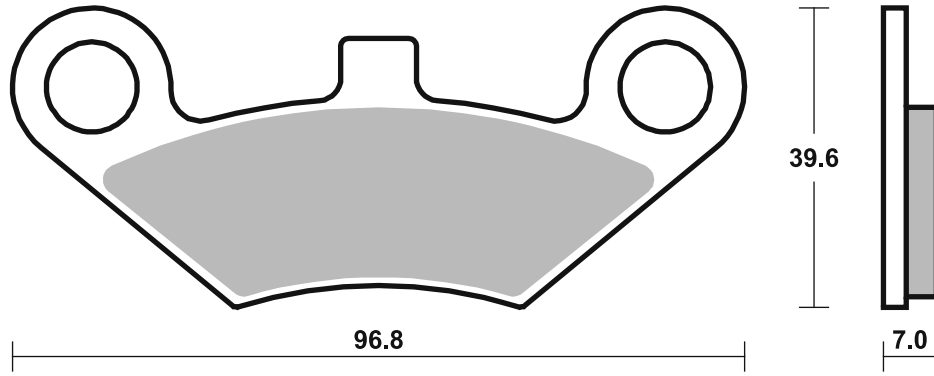

Available compounds

HF • SI • RSI

SBS 915

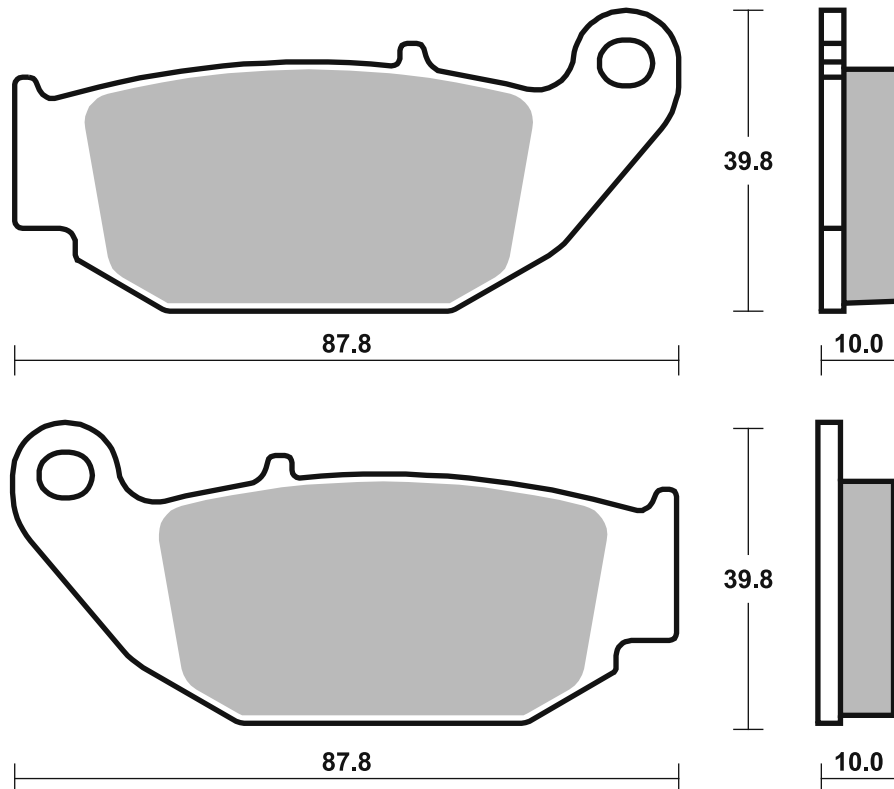

# Applications

## SBS 920

## Recommended compound



<b>SUZUKI</b>			
C	1800 R Intruder	08 - 11	LS
M	1800 R Intruder	06 - 16	LS
M	1800 R2 Intruder	08 - 10	LS
M	1800 RBZ Intruder	16 - 17	LS

## SBS 921

## Recommended compound



<b>KYMCO</b>			
	400 Maxxer		
	(Parking Brake)	08 - 10	HF
	400 MXU		
	(Parking Brake)	08 - 11	HF
	450 i Maxxer		
	(Parking Brake)	10 - 14	HF
	450 i MXU		
	(Parking Brake)	11 - 14	HF

Brake Pad 1:1 Drawings,  
Compounds, Fitments

STREET  
AMERICAN  
SCOOTER

HF • HS • LS  
H.HF • H.CT • H.HS • H.LS  
HF • CT • MS

RACING  
OFF ROAD  
ATV

RST • DC • DCC • DS-1 • DS-2 • RQ  
SI • RSI • CS  
ATS • SI • RSI • PSI

Drawings 1:1

Available compounds

HF • LS

SBS 920

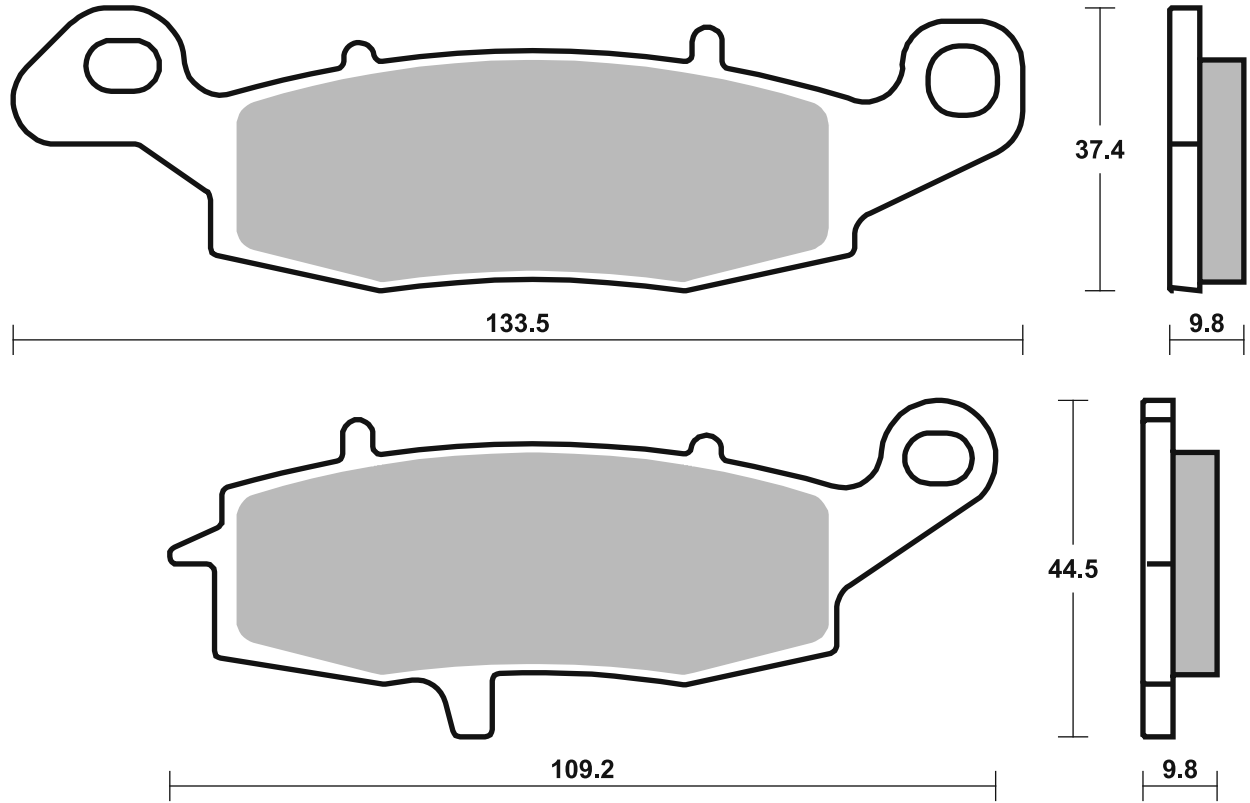

Available compounds

HF

SBS 921

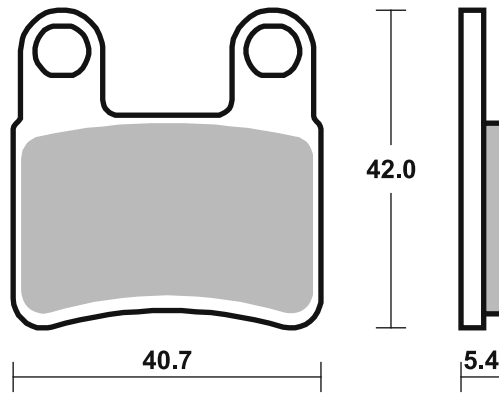



**HARLEY DAVIDSON**

FLHTCUTG	1690	Tri Glide Ultra	14 - 16	<b>H.HS</b>
FLRT	1690	Freewheeler	15 - 16	<b>H.HS</b>
FLHTCUTG	1750	Tri Glide Ultra	17 - 18	<b>H.HS</b>
FLRT	1750	Freewheeler	17 - 18	<b>H.HS</b>

STREET  
AMERICAN  
SCOOTER

HF • HS • LS  
H.HF • H.CT • H.HS • H.LS  
HF • CT • MS

RACING  
OFF ROAD  
ATV

RST • DC • DCC • DS-1 • DS-2 • RQ  
SI • RSI • CS  
ATS • SI • RSI • PSI

Available compounds

H.HS

SBS 922

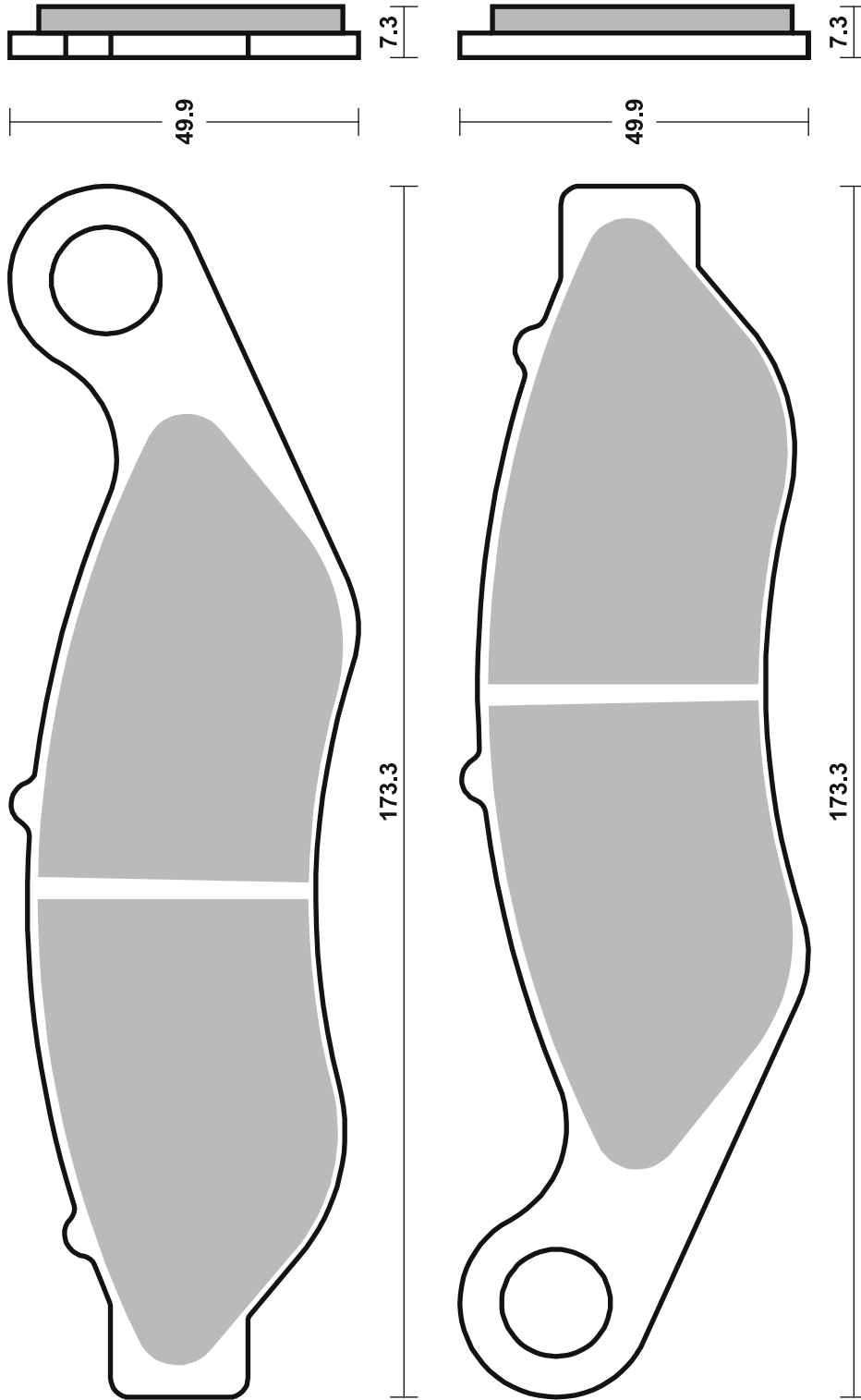

# Applications

## SBS 923

### Recommended compound



#### HARLEY DAVIDSON

FLHTCUTG	1690 Tri Glide Ultra	14 - 16	<b>H.LS</b>	
FLRT	1690 Freewheeler	15 - 16	<b>H.LS</b>	
FLHTCUTG	1750 Tri Glide Ultra	17 - 18	<b>H.LS</b>	
FLRT	1750 Freewheeler	17 - 18	<b>H.LS</b>	

## SBS 924

### Recommended compound



#### HARLEY DAVIDSON

XG	500 Street	14 - 15	<b>H.HF</b>	<b>H.HF</b>
XG	750 Street	14 - 15	<b>H.HF</b>	<b>H.HF</b>

Brake Pad 1:1 Drawings, Compounds, Fitments



STREET  
AMERICAN  
SCOOTER

HF • HS • LS  
H.HF • H.CT • H.HS • H.LS  
HF • CT • MS

RACING  
OFF ROAD  
ATV

RST • DC • DCC • DS-1 • DS-2 • RQ  
SI • RSI • CS  
ATS • SI • RSI • PSI

Drawings 1:1

Available compounds

H.LS

SBS 923

1 set = 4 pcs.

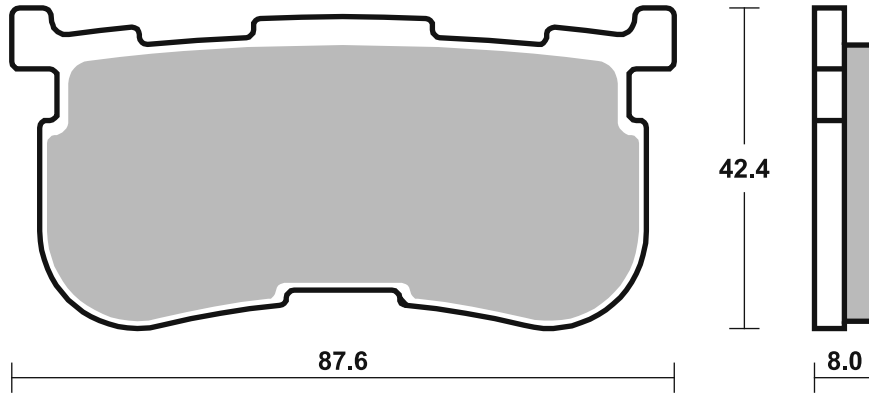

Available compounds

H.HF • H.CT • H.HS • H.LS

SBS 924

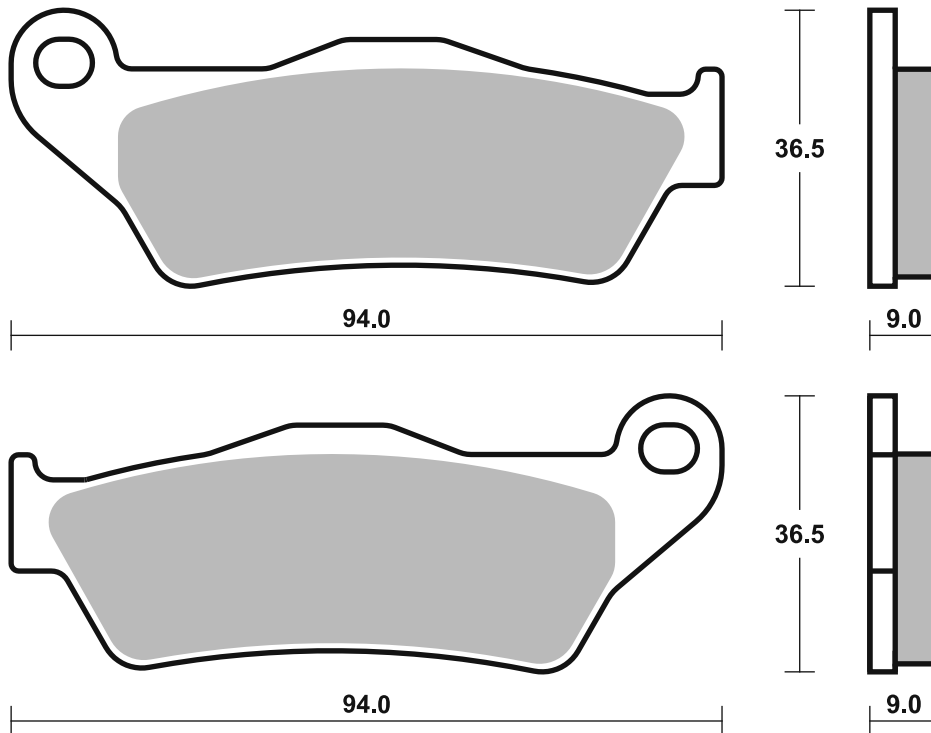



STREET  
AMERICAN  
SCOOTER

HF • HS • LS  
H.HF • H.CT • H.HS • H.LS  
HF • CT • MS

RACING  
OFF ROAD  
ATV

RST • DC • DCC • DS-1 • DS-2 • RQ  
SI • RSI • CS  
ATS • SI • RSI • PSI

Drawings 1:1

Available compounds

HF • RSI

SBS 925

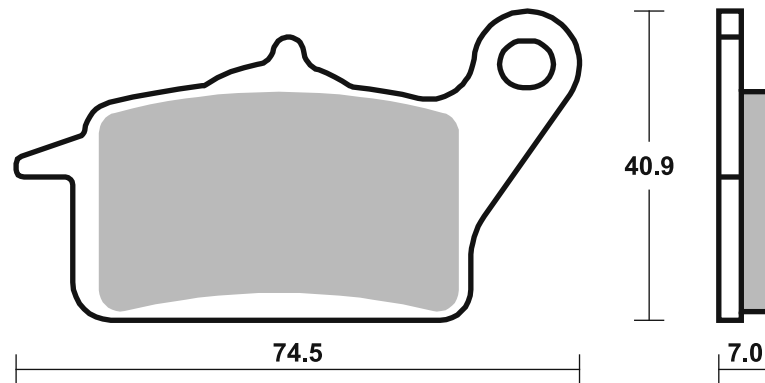
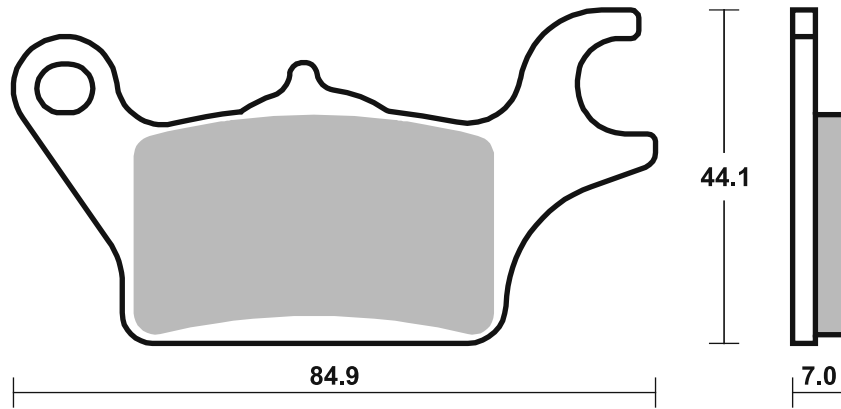

Available compounds

HF

SBS 926

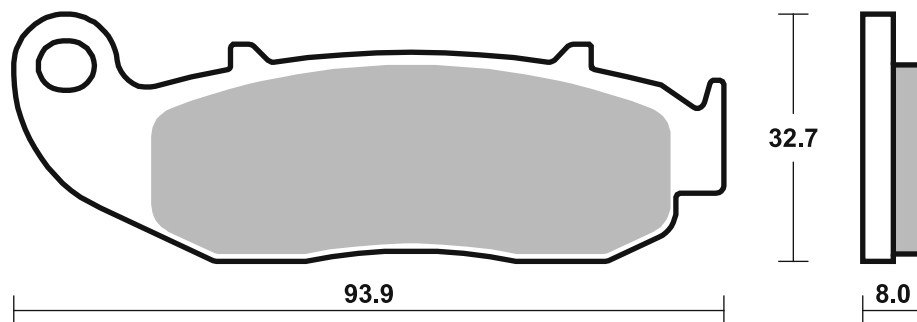
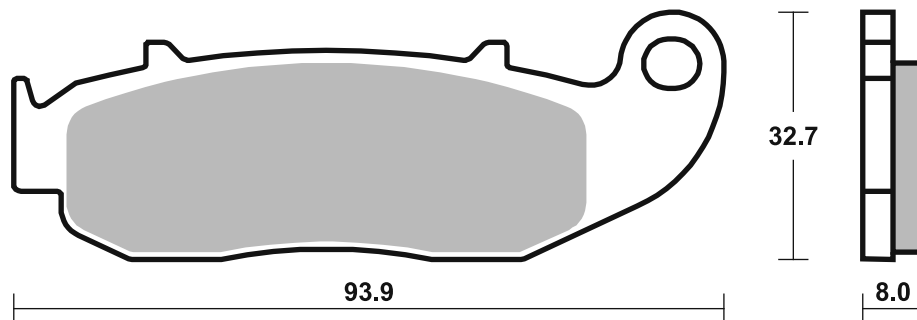

## Applications

### SBS 928 Recommended compound



HM			
CRE	50 Six Comp.	07 - 12	HF
CRM	50 Derapage Comp.	07 - 12	HF
CRE	125 Six Comp.	10 - 11	HF
CRM	125 Derapage Comp.		
	2T	11 - 12	HF
CRM	125 Derapage Comp.		
	4T	11 - 12	HF

### SBS 929 Recommended compound



INDIAN			
	1000 Scout Sixty	16 - 16	H.HS
	1130 Scout	15 - 16	H.HS

Brake Pad 1:1 Drawings,  
Compounds, Fitments

STREET  
AMERICAN  
SCOOTER

HF • HS • LS  
H.HF • H.CT • H.HS • H.LS  
HF • CT • MS

RACING  
OFF ROAD  
ATV

RST • DC • DCC • DS-1 • DS-2 • RQ  
SI • RSI • CS  
ATS • SI • RSI • PSI

Drawings 1:1

Available compounds

HF

SBS 928

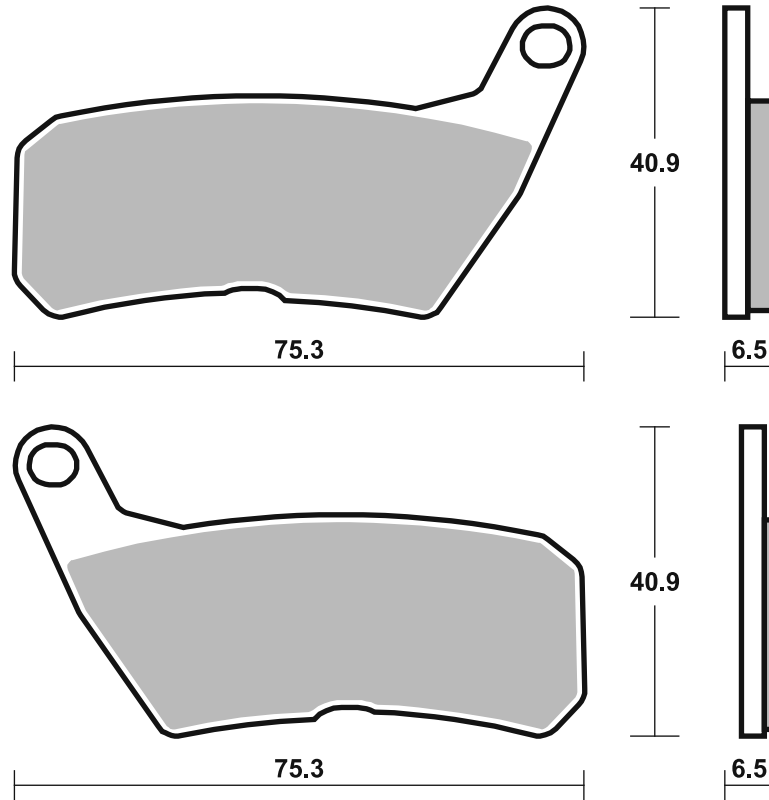

Available compounds

H.HF • H.CT • H.HS

SBS 929

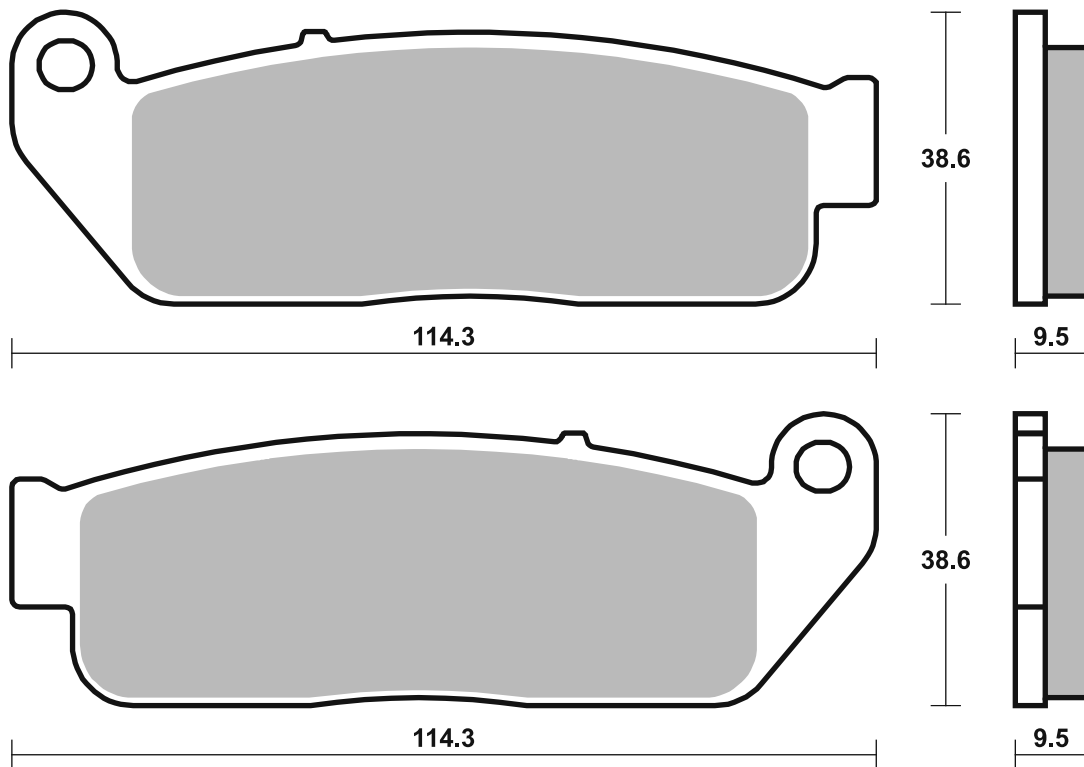



STREET  
AMERICAN  
SCOOTER

HF • HS • LS  
H.HF • H.CT • H.HS • H.LS  
HF • CT • MS

RACING  
OFF ROAD  
ATV

RST • DC • DCC • DS-1 • DS-2 • RQ  
SI • RSI • CS  
ATS • SI • RSI • PSI

Drawings 1:1

Available compounds

H.HF • H.CT • H.LS

SBS 930

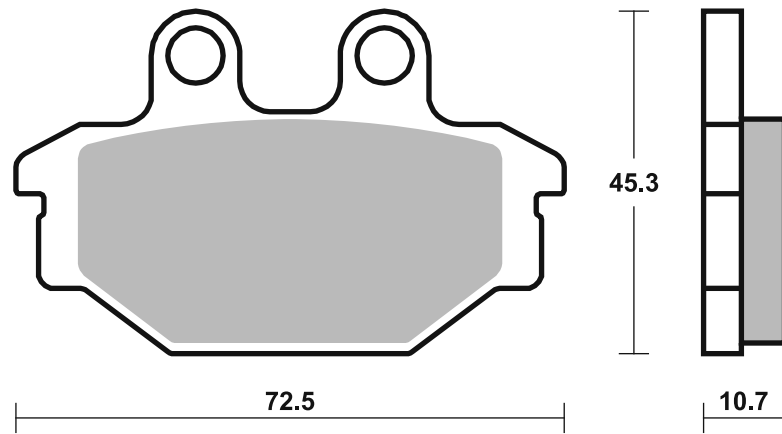
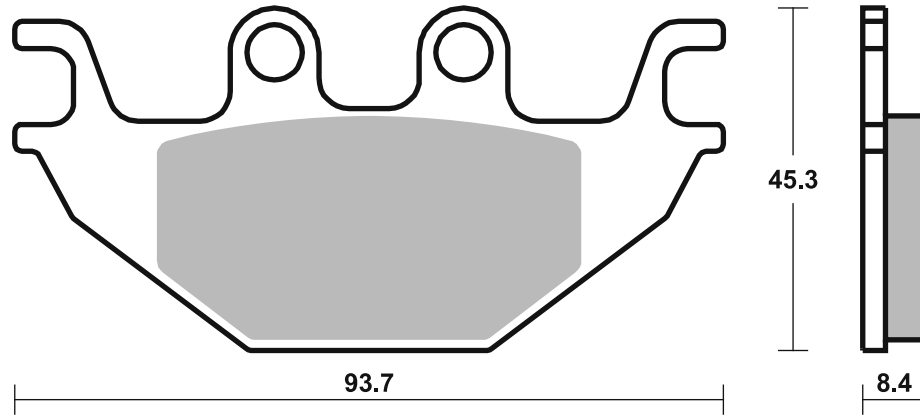

Available compounds

HF • HS • DC • RST • DS-1 • DS-2

SBS 931

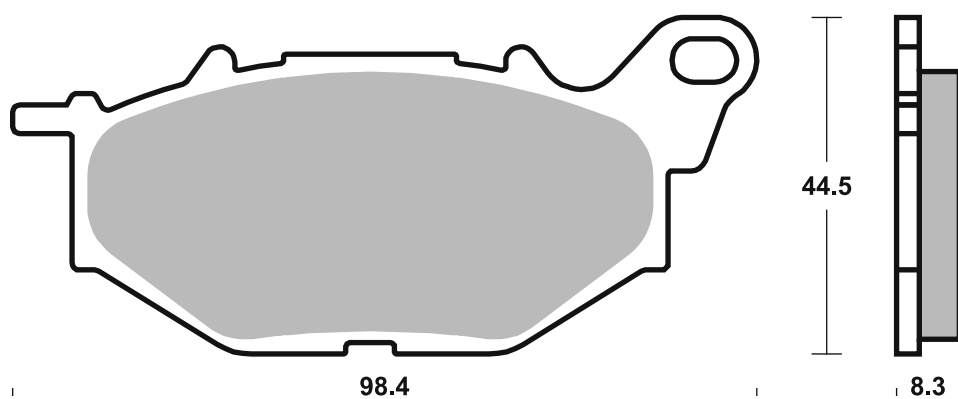
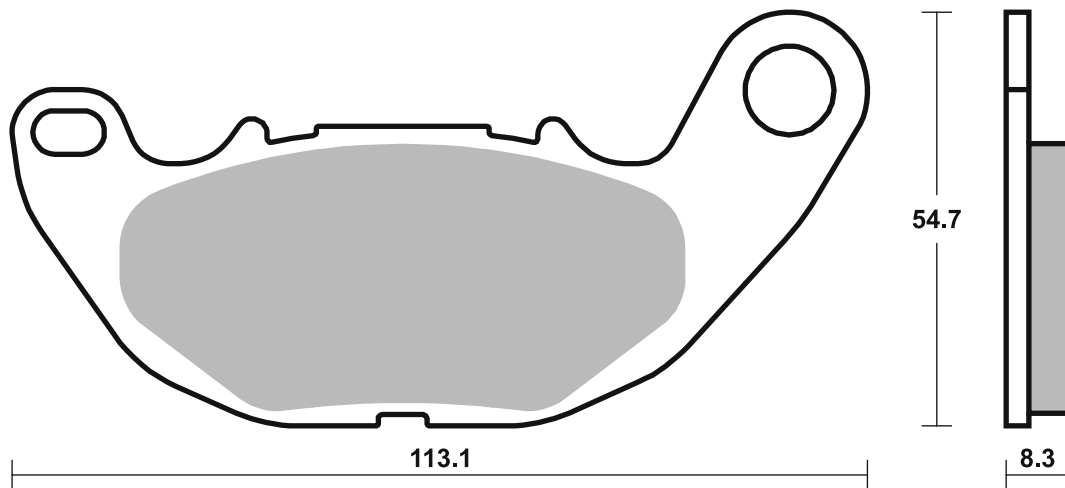

Dimensions in mm / Dimensions en mm  
1" = 25.4 mm, 1 mm = 0.04"

Brake Pad 1:1 Drawings,  
Compounds, Fitsments

# Applications

## SBS 932

### Recommended compound



#### YAMAHA

MT-25	250	16 - 17	HF
YZF	250 R25	15 - 20	HF
MT-03	321	16 - 24	HF
YZF	321 R3	15 - 24	HF

## SBS 933

### Recommended compound



#### BENELLI

	250 Leoncino	18 - 20	HS
BN	251	15 - 19	HS
TRK	251	19 - 24	HS
	300 Tornado	24 - 24	HS
BN	302	15 - 15	HS
BN	302 R	17 - 19	HS
BN	302 S	18 - 19	HS
BN	302 Tornado	16 - 16	HS

#### PEUGEOT

PM-01	300	23 - 23	HS



STREET  
AMERICAN  
SCOOTER

HF • HS • LS  
H.HF • H.CT • H.HS • H.LS  
HF • CT • MS

RACING  
OFF ROAD  
ATV

RST • DC • DCC • DS-1 • DS-2 • RQ  
SI • RSI • CS  
ATS • SI • RSI • PSI

Drawings 1:1

Available compounds

HF • RQ

SBS 932

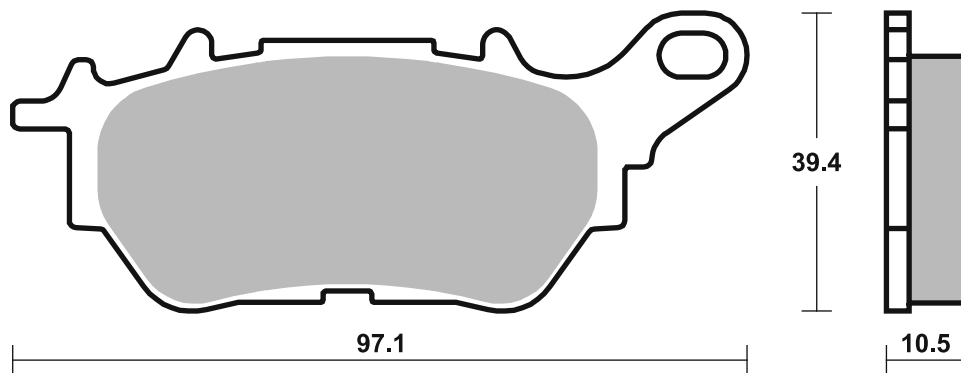
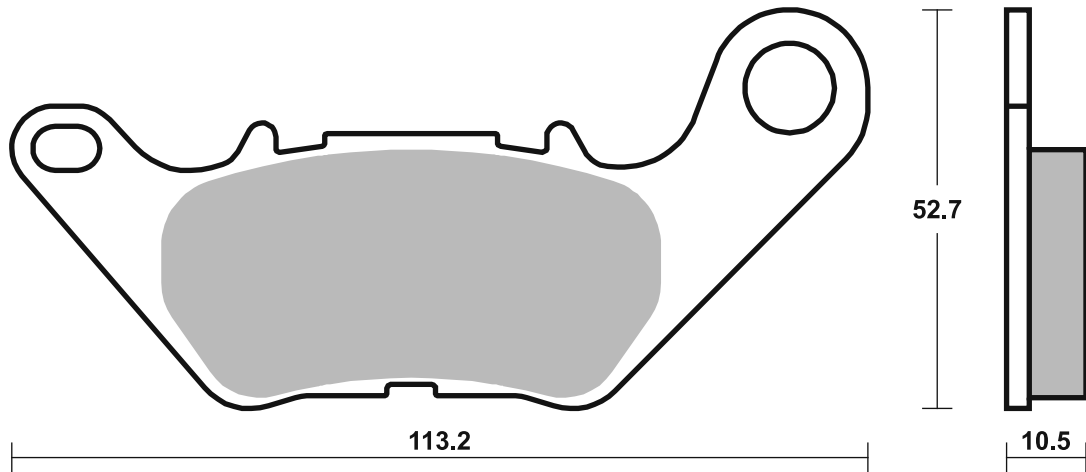

Available compounds

HS

SBS 933

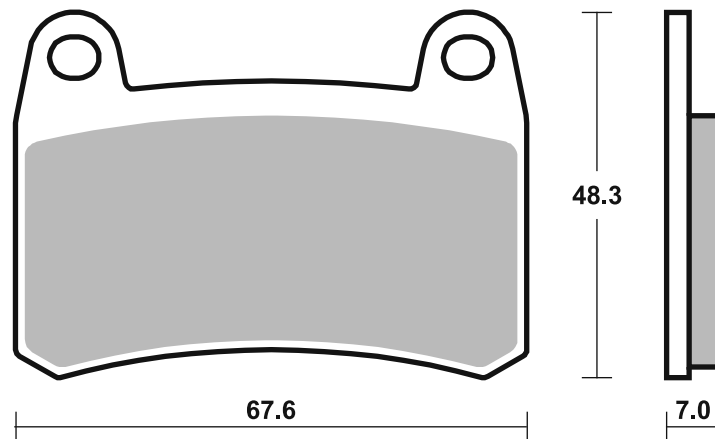



STREET  
AMERICAN  
SCOOTER

HF • HS • LS  
H.HF • H.CT • H.HS • H.LS  
HF • CT • MS

RACING  
OFF ROAD  
ATV

RST • DC • DCC • DS-1 • DS-2 • RQ  
SI • RSI • CS  
ATS • SI • RSI • PSI

Drawings 1:1

Available compounds

H.HF • H.CT • H.HS

SBS 934

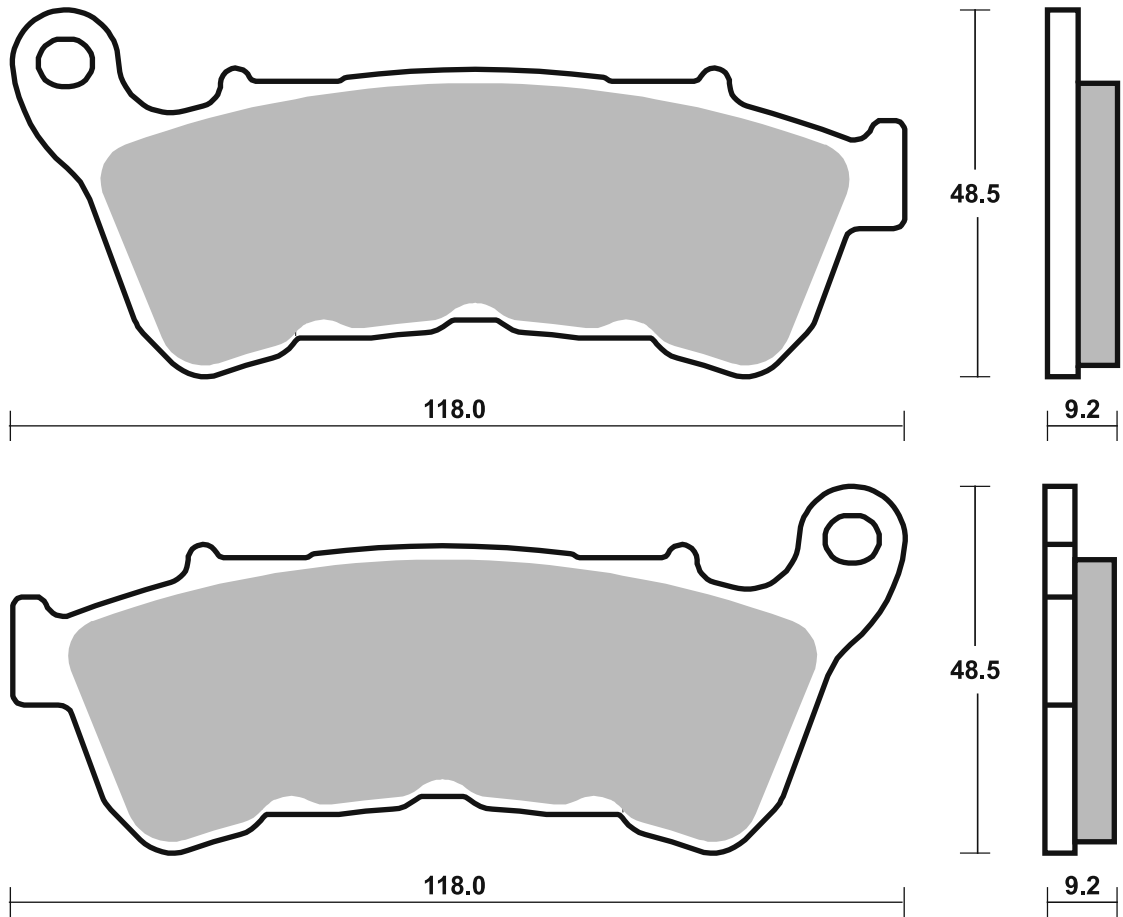

Available compounds

HF • RSI

SBS 939

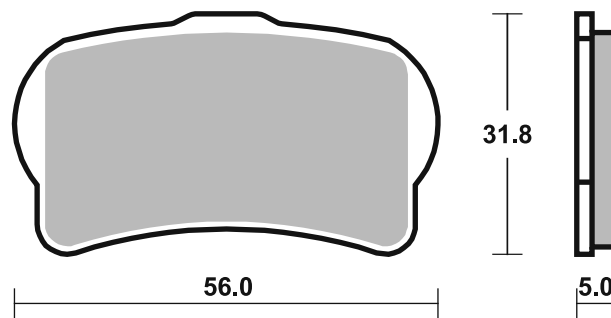

## Applications

### SBS 940

### Recommended compound



<b>HONDA</b>			
CB	125 R	18 - 24	<b>HS</b>
CB	300 R	18 - 24	<b>HS</b>
CB	300 R Neo Sports Cafe	19 - 19	<b>HS</b>
CB	650 R Neo Sports Cafe	19 - 21	<b>HS</b>
CBR	650 R	19 - 24	<b>HS</b>
CB	1000 Hornet	24 - 24	<b>HS</b>
CRF	1000 L Africa Twin	16 - 19	<b>HS</b>
CRF	1000 L Africa Twin Adventure Sports	18 - 19	<b>HS</b>
CRF	1100 L Africa Twin	20 - 24	<b>HS</b>
CRF	1100 L Africa Twin Adventure Sports	20 - 24	<b>HS</b>
NT	1100	22 - 24	<b>HS</b>

### SBS 941

### Recommended compound



<b>BREMBO RACING CALIPERS</b>			
	Racing rear X206101,		
	P4 24 (30 mm disc height)		
	Racing rear X206121,		
	P4 24 (30 mm disc height)		
	Racing rear X988870,		
	P2 34 (30 mm disc height)		
	Racing rear XA1J040,		
	P2 30 (30 mm disc height)		

### SBS 942

### Recommended compound



<b>BMW</b>			
S	1000 HP4 Race	17 - 18	<b>LS</b>
<b>BREMBO RACING CALIPERS</b>			
	Racing rear X206101,		
	P4 24 (24 mm disc height)		
	Racing rear X206121,		
	P4 24 (24 mm disc height)		
	Racing rear X988870,		
	P2 34 (24 mm disc height)		
	Racing rear XA1J040,		
	P2 30 (24 mm disc height)		

STREET  
AMERICAN  
SCOOTER

HF • HS • LS  
H.HF • H.CT • H.HS • H.LS  
HF • CT • MS

RACING  
OFF ROAD  
ATV

RST • DC • DCC • DS-1 • DS-2 • RQ  
SI • RSI • CS  
ATS • SI • RSI • PSI

Drawings 1:1

Available compounds

HS • RST

SBS 940

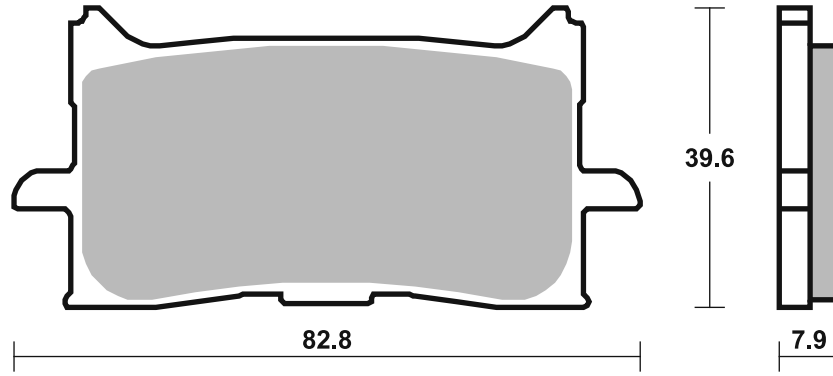

Available compounds

LS • RST • RQ • RSI

SBS 941

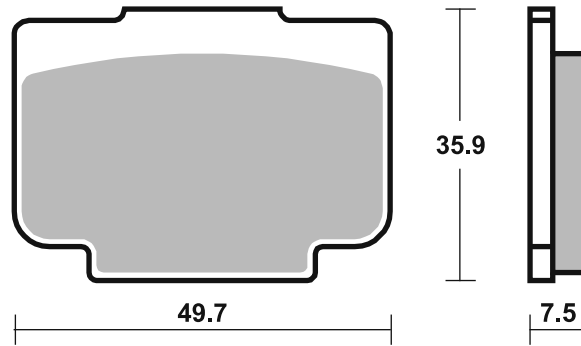

Available compounds

LS • RQ

SBS 942

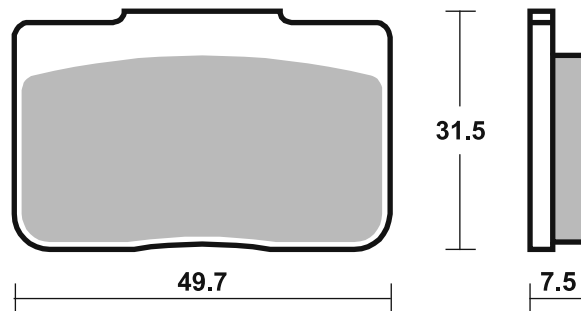

# Applications

## SBS 944

### Recommended compound



#### RBS CARS

Model	Year	Compound
900 Adventure	15 - 16	HS

## SBS 945

### Recommended compound



#### KYMCO

Model	Year	Compound
500 MXU	09 - 14	SI
500 MXU DX	11 - 13	SI
550 MXU	12 - 20	SI
700 MXU	13 - 20	SI
UXV 700	14 - 16	SI

## SBS 946

### Recommended compound



#### ARCTIC CAT

Model	Year	Compound
700 Wildcat Sport	15 - 18	ATS
700 Wildcat Sport LTD.	16 - 18	ATS
700 Wildcat Sport LTD. EPS	17 - 18	ATS
700 Wildcat Sport SE EPS	17 - 19	ATS
700 Wildcat Sport XT	15 - 18	ATS
700 Wildcat Sport XT EPS	16 - 18	ATS

Brake Pad 1:1 Drawings,  
Compounds, Fitments

STREET  
AMERICAN  
SCOOTER

HF • HS • LS  
H.HF • H.CT • H.HS • H.LS  
HF • CT • MS

RACING  
OFF ROAD  
ATV

RST • DC • DCC • DS-1 • DS-2 • RQ  
SI • RSI • CS  
ATS • SI • RSI • PSI

Drawings 1:1

Available compounds

HS

SBS 944

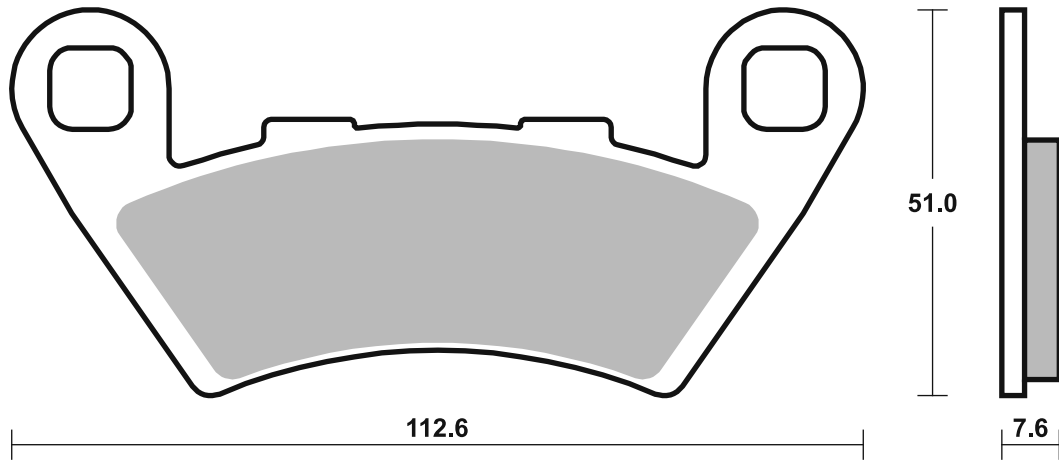

Available compounds

SI • RSI

SBS 945

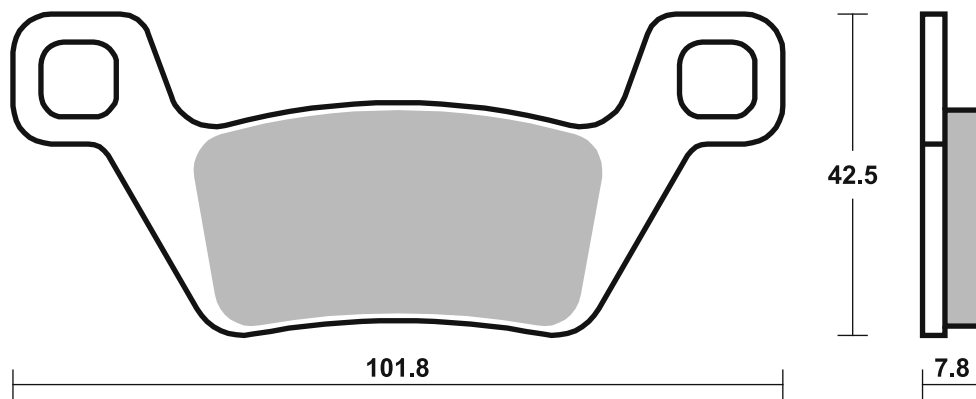

Available compounds

SI • RSI • ATS

SBS 946

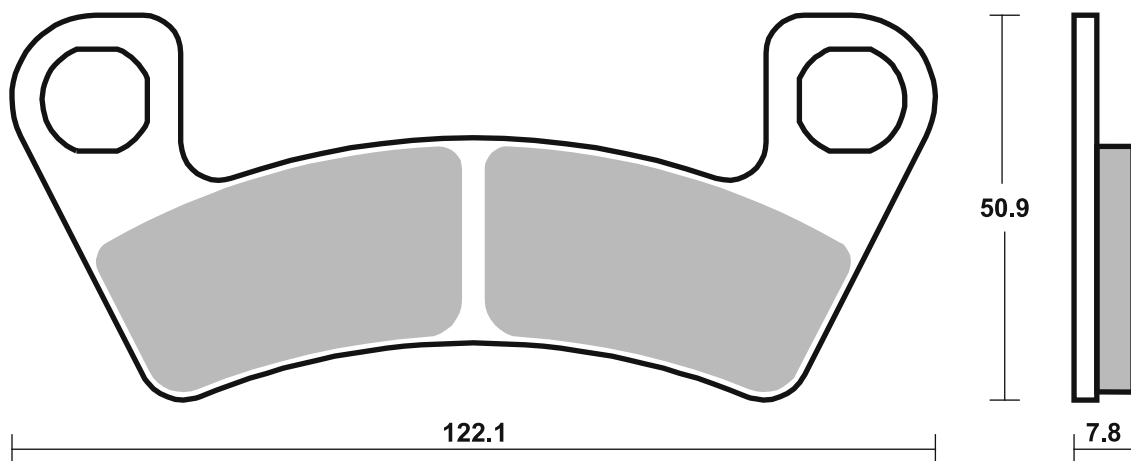

## Applications

### SBS 947

#### Recommended compound



<b>HONDA</b>			
CBR	600 RR	18 - 24	<b>HS</b>
VFR	800 F	17 - 19	<b>HS</b>
VFR	800 X		
	Crossrunner	17 - 18	<b>HS</b>
CB	1000 R	18 - 24	<b>HS</b>
CB	1000 R+ Neo		
	Sports Cafe	18 - 18	<b>HS</b>
CBR	1000 RR Fireblade	17 - 22	<b>HS</b>
CB	1100 RS ABS	17 - 21	<b>HS</b>
CMX	1100 Rebel	21 - 22	<b>HS</b>

### SBS 948

#### Recommended compound



<b>CAN-AM</b>			
	1330 Spyder F3	15 - 22	<b>HS</b>
	1330 Spyder F3		
	Limited	16 - 22	<b>HS</b>
	1330 Spyder F3-S	15 - 22	<b>HS</b>
	1330 Spyder F3-T	16 - 22	<b>HS</b>
	1330 Spyder RS	14 - 16	<b>HS</b>
	1330 Spyder RS		
	RSS	13 - 13	<b>HS</b>
	1330 Spyder RSS	14 - 15	<b>HS</b>
	1330 Spyder RSS		
	Special		
	Series	15 - 15	<b>HS</b>
	1330 Spyder RT	14 - 22	<b>HS</b>
	1330 Spyder RT		
	Limited	13 - 22	<b>HS</b>
	1330 Spyder RT		
	RTS	13 - 13	<b>HS</b>
	1330 Spyder RTS	14 - 15	<b>HS</b>
	1330 Spyder RTS		
	Special		
	Series	15 - 15	<b>HS</b>
	1330 Spyder ST	14 - 16	<b>HS</b>
	1330 Spyder ST		
	Limited	13 - 15	<b>HS</b>
	1330 Spyder ST		
	STS	13 - 13	<b>HS</b>
	1330 Spyder STS	14 - 15	<b>HS</b>
	1330 Spyder STS		
	Special		
	Series	15 - 15	<b>HS</b>



<b>DAVINCI</b>			
	DC100	22 - 23	<b>HS</b>
<b>HARLEY DAVIDSON</b>			
FLHTCUTG	1870 Tri Glide Ultra	19 - 22	<b>H.HS</b>
FLRT	1870 Freewheeler	19 - 22	<b>H.HS</b>
FLHTCUTGSE	1917 CVO Tri Glide	20 - 22	<b>H.HS</b>

Brake Pad 1:1 Drawings, Compounds, Fitments



STREET  
AMERICAN  
SCOOTER

HF • HS • LS  
H.HF • H.CT • H.HS • H.LS  
HF • CT • MS

RACING  
OFF ROAD  
ATV

RST • DC • DCC • DS-1 • DS-2 • RQ  
SI • RSI • CS  
ATS • SI • RSI • PSI

Drawings 1:1

Available compounds

HS • DC • RST • DS-1 • DS-2

SBS 947

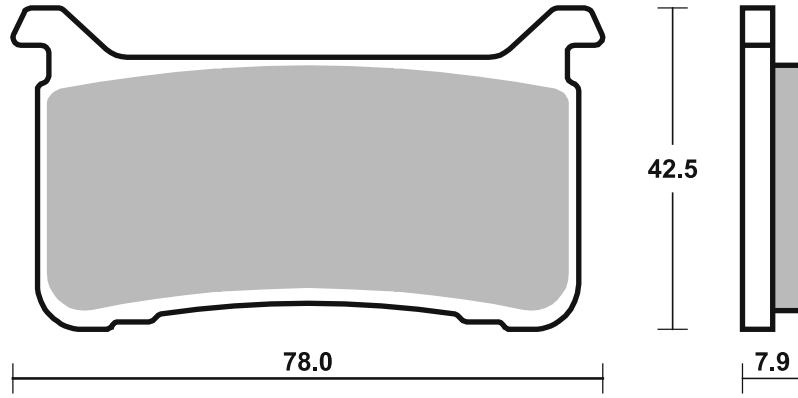

Available compounds

HS • H.HS

SBS 948

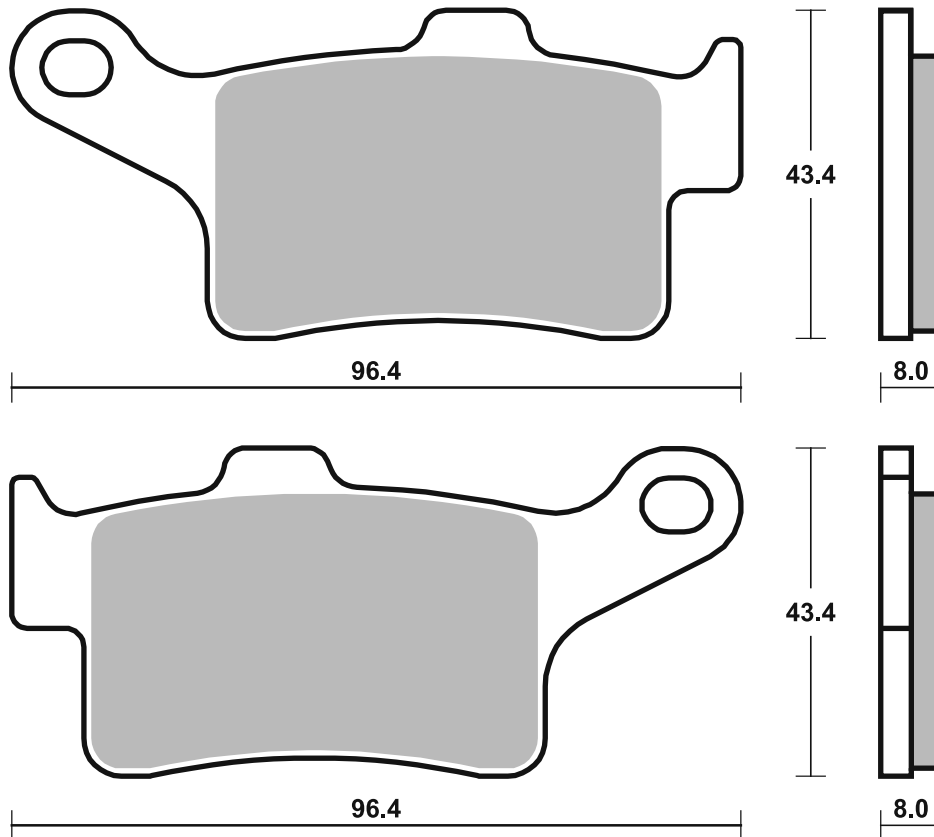

Dimensions in mm / Dimensions en mm  
1" = 25.4 mm, 1 mm = 0.04"

Brake Pad 1:1 Drawings,  
Compounds, Fitments



STREET  
AMERICAN  
SCOOTER

HF • HS • LS  
H.HF • H.CT • H.HS • H.LS  
HF • CT • MS

RACING  
OFF ROAD  
ATV

RST • DC • DCC • DS-1 • DS-2 • RQ  
SI • RSI • CS  
ATS • SI • RSI • PSI

Drawings 1:1

Available compounds

H.HF • H.CT • H.LS

SBS 949

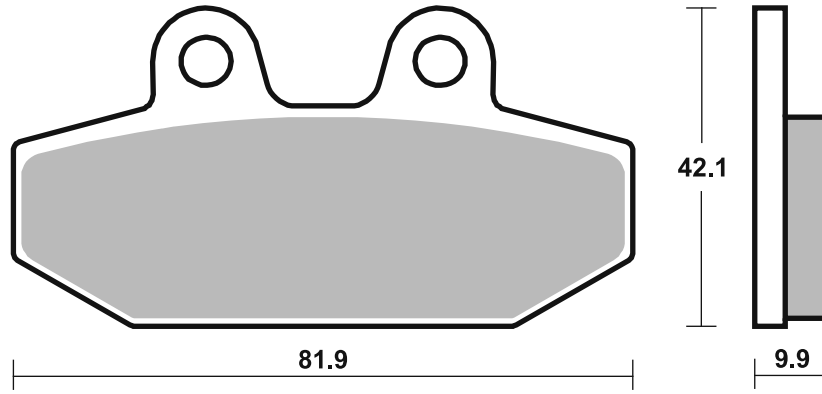

Available compounds

DS-1 • DS-2

SBS 950

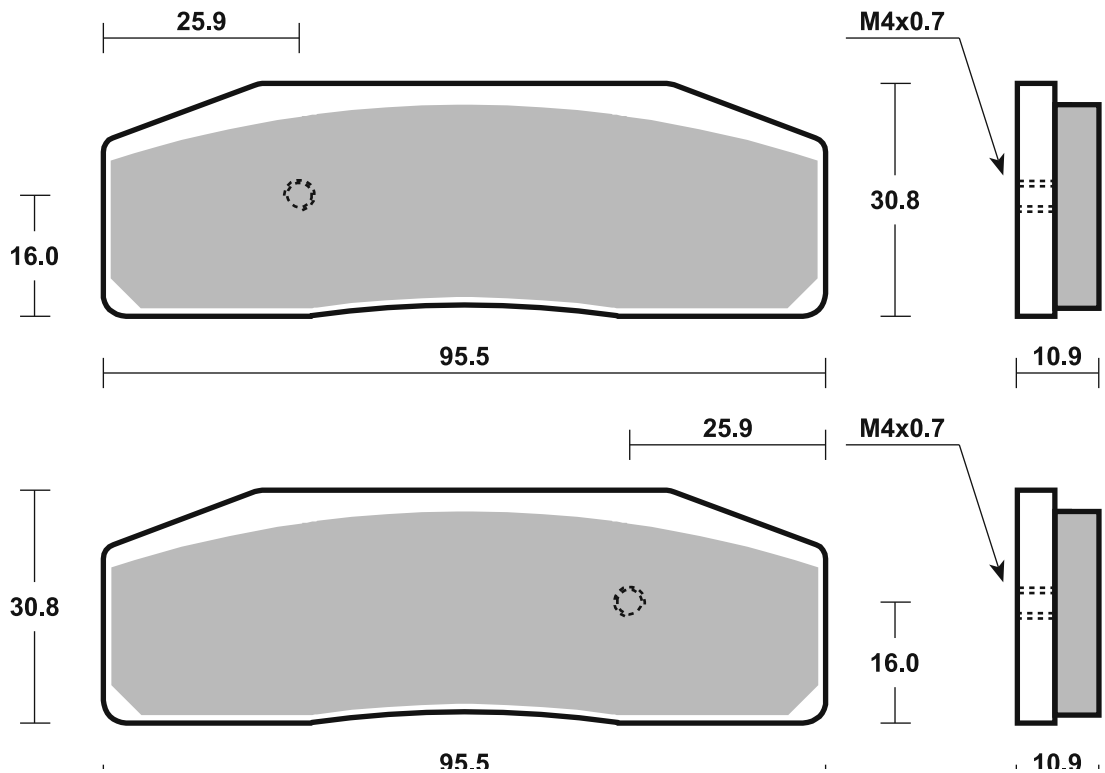

SBS 951

Recommended compound



SUZUKI			
GSX-R	125 RL	17 - 24	HF
GSX-R	125 RLX	17 - 24	HF
GSX-S	125 ML	17 - 24	HF
GSX-S	125 MLX	17 - 24	HF

SBS 952

Recommended compound



HONDA			
GL	1800 Gold Wing	18 - 24	HS

Brake Pad 1:1 Drawings,  
Compounds, Fitments

STREET  
AMERICAN  
SCOOTER

HF • HS • LS  
H.HF • H.CT • H.HS • H.LS  
HF • CT • MS

RACING  
OFF ROAD  
ATV

RST • DC • DCC • DS-1 • DS-2 • RQ  
SI • RSI • CS  
ATS • SI • RSI • PSI

Drawings 1:1

Available compounds

HF • HS • RST

SBS 951

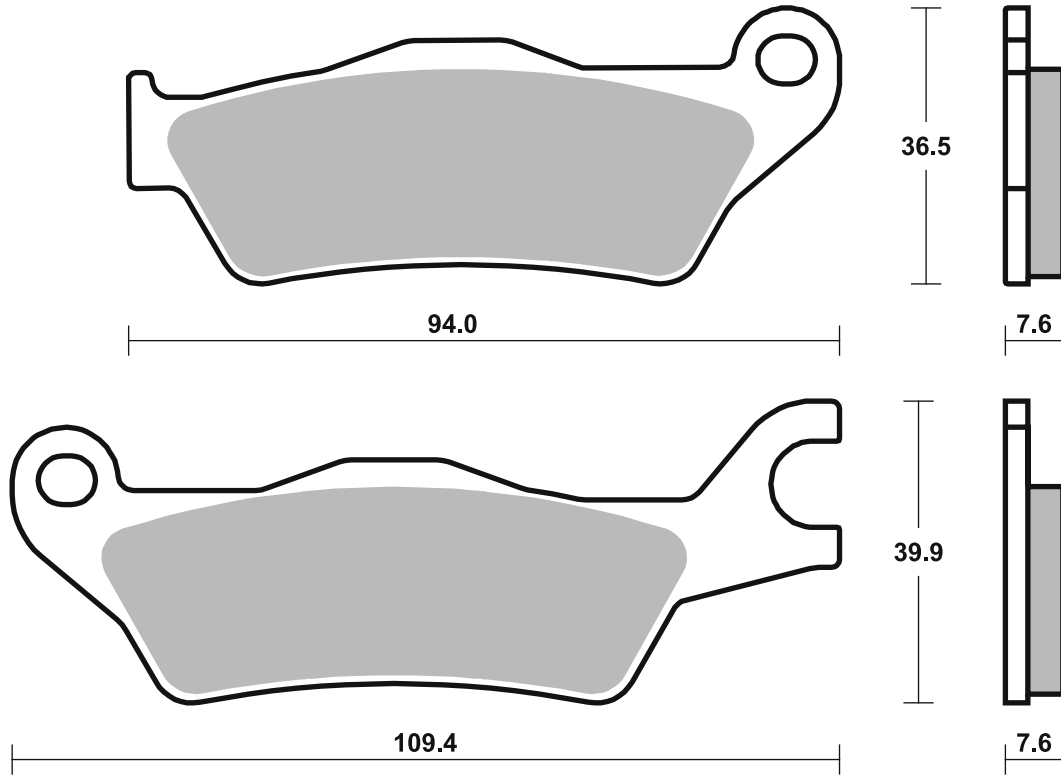

Available compounds

HS

SBS 952

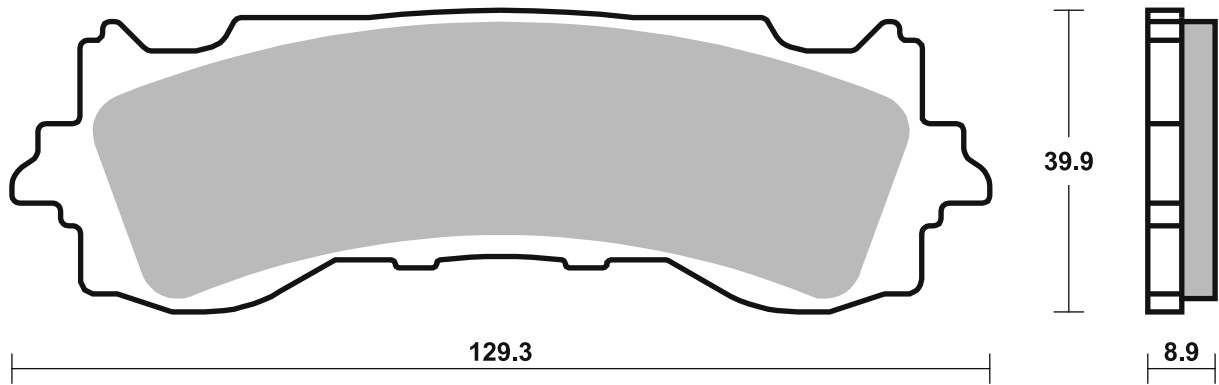



STREET  
AMERICAN  
SCOOTER

HF • HS • LS  
H.HF • H.CT • H.HS • H.LS  
HF • CT • MS

RACING  
OFF ROAD  
ATV

RST • DC • DCC • DS-1 • DS-2 • RQ  
SI • RSI • CS  
ATS • SI • RSI • PSI

Drawings 1:1

Available compounds

LS

SBS 953

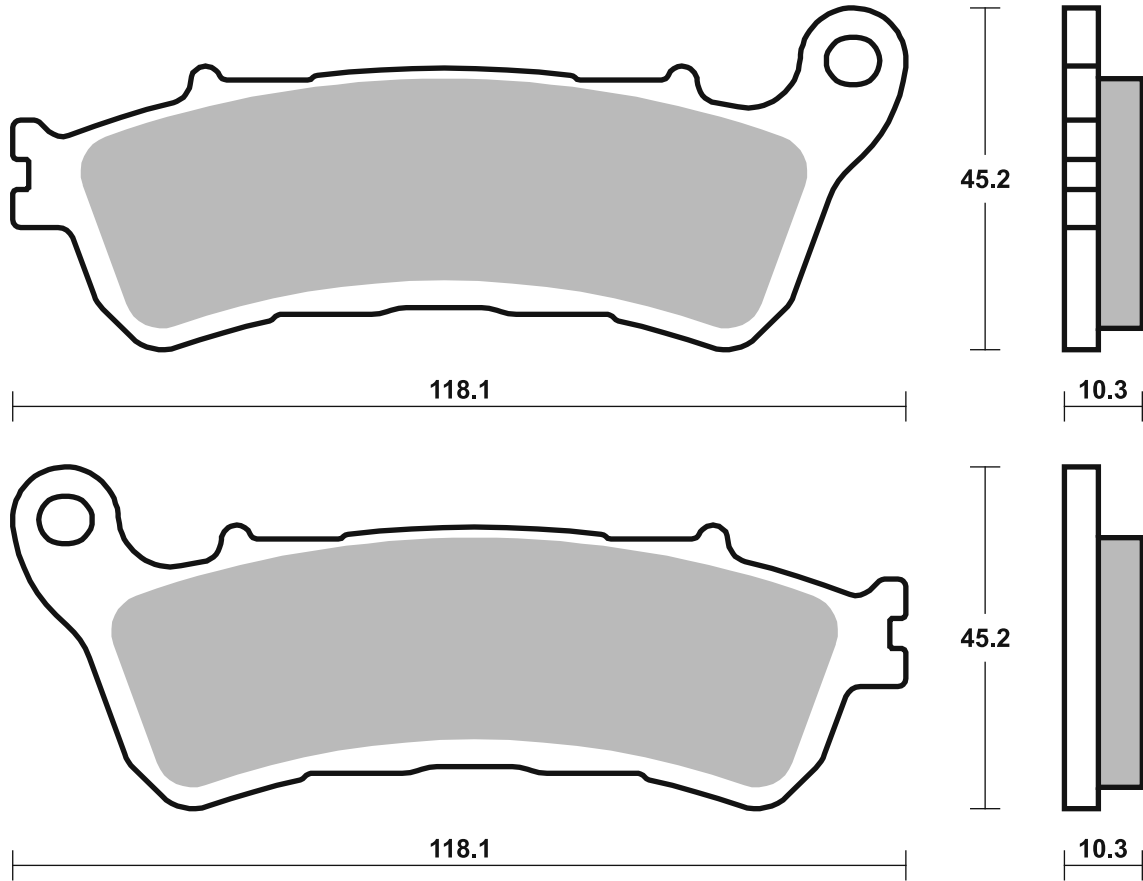





STREET  
AMERICAN  
SCOOTER

HF • HS • LS  
H.HF • H.CT • H.HS • H.LS  
HF • CT • MS

RACING  
OFF ROAD  
ATV

RST • DC • DCC • DS-1 • DS-2 • RQ  
SI • RSI • CS  
ATS • SI • RSI • PSI

Available compounds

SI • RSI

SBS 954

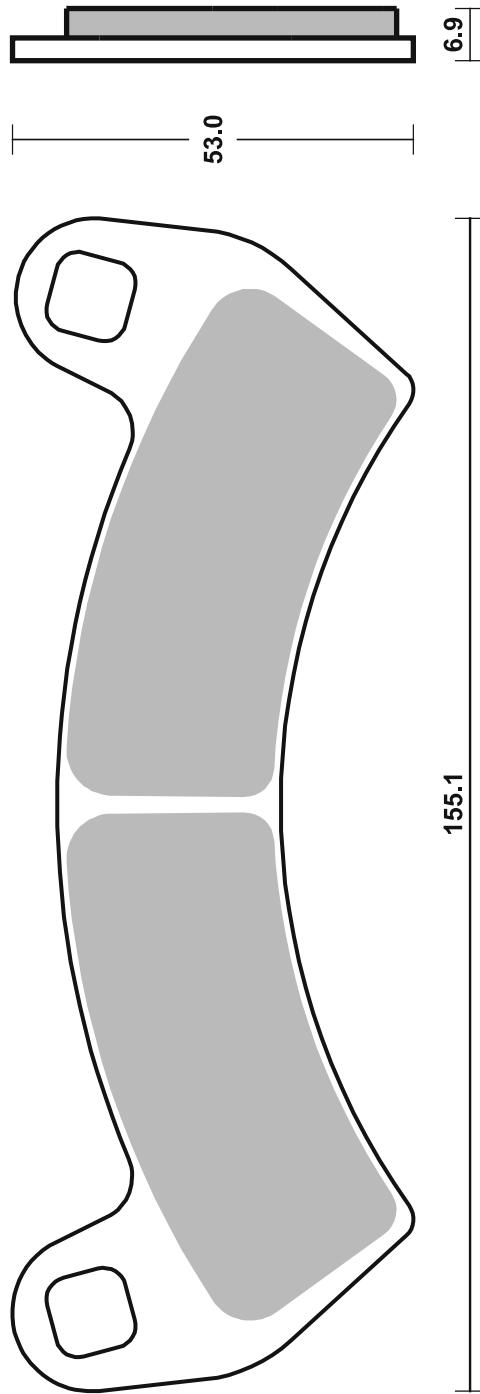



**KAWASAKI**

EX	250 R Ninja	18 - 20	HS
EX	400 Ninja	18 - 23	HS
EX	400 Ninja SE	18 - 23	HS
Z	400	19 - 24	HS
	500 Eliminator	24 - 24	HS
	500 Eliminator SE	24 - 24	HS
	500 Ninja	24 - 24	HS
	500 Ninja SE	24 - 24	HS
Z	500	24 - 24	HS
Z	500 SE	24 - 24	HS

STREET  
AMERICAN  
SCOOTER

HF • HS • LS  
H.HF • H.CT • H.HS • H.LS  
HF • CT • MS

RACING  
OFF ROAD  
ATV

RST • DC • DCC • DS-1 • DS-2 • RQ  
SI • RSI • CS  
ATS • SI • RSI • PSI

Available compounds

HS • DC • RST • DS-1 • DS-2

SBS 955

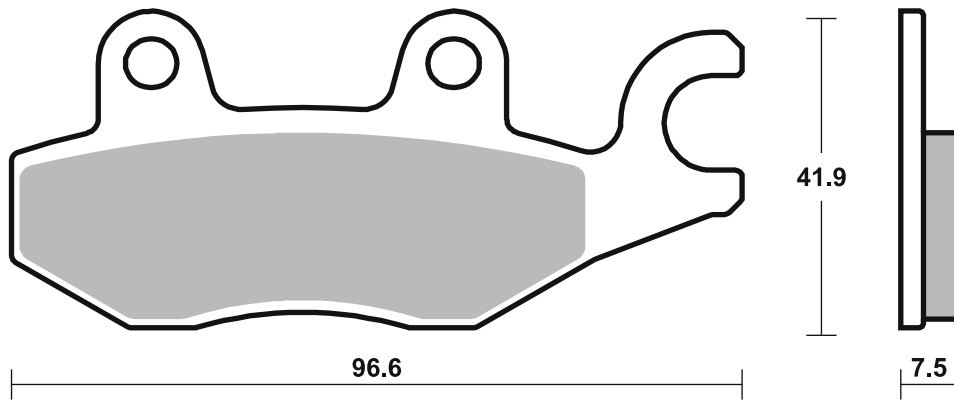
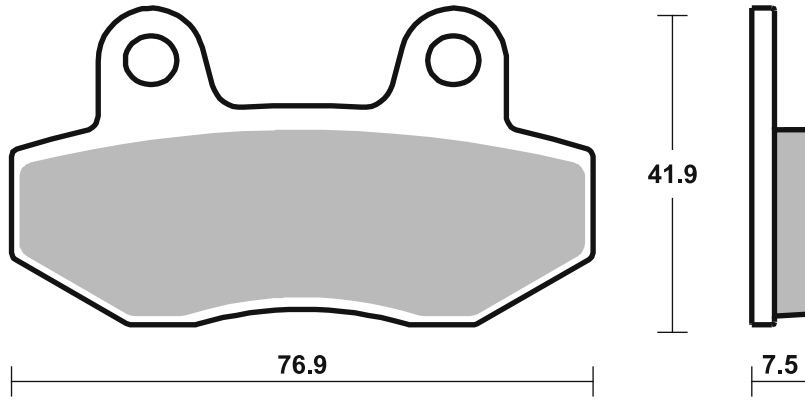



<b>CAN-AM</b>			
427 Defender HD5	18 - 18	PSI	
427 Traxter HD5	18 - 18	PSI	
650 Defender HD7	22 - 23	PSI	
650 Traxter HD7	23 - 23	PSI	
650 Traxter T HD7	22 - 22	PSI	
700 Maverick Trail	22 - 23	PSI	PSI
800 Defender HD8	17 - 21	PSI	
800 Maverick Trail	18 - 21	PSI	PSI
800 Traxter HD8	16 - 21	PSI	
800 Traxter T HD8	18 - 21	PSI	
900 X3	17 - 23	PSI	PSI
900 X3 MAX	17 - 23	PSI	PSI
900 X3 MAX Turbo	18 - 23	PSI	PSI
900 X3 MAX Turbo R	18 - 23	PSI	PSI
900 X3 Turbo	18 - 23	PSI	PSI
900 X3 Turbo R	18 - 23	PSI	PSI
976 Defender HD10	17 - 23	PSI	
976 Defender HD9	22 - 23	PSI	
976 Traxter HD10	17 - 23	PSI	
976 Traxter HD9	22 - 23	PSI	
976 Traxter T HD10	18 - 22	PSI	
976 Traxter T HD9	22 - 23	PSI	
1000 Maverick	19 - 23	PSI	PSI
1000 Maverick MAX	19 - 23	PSI	PSI
1000 Maverick Sport	18 - 23	PSI	PSI
1000 Maverick Trail	18 - 23	PSI	PSI

STREET  
AMERICAN  
SCOOTER

HF • HS • LS  
H.HF • H.CT • H.HS • H.LS  
HF • CT • MS

RACING  
OFF ROAD  
ATV

RST • DC • DCC • DS-1 • DS-2 • RQ  
SI • RSI • CS  
ATS • SI • RSI • PSI

Drawings 1:1

Available compounds

SI • RSI • PSI

SBS 956

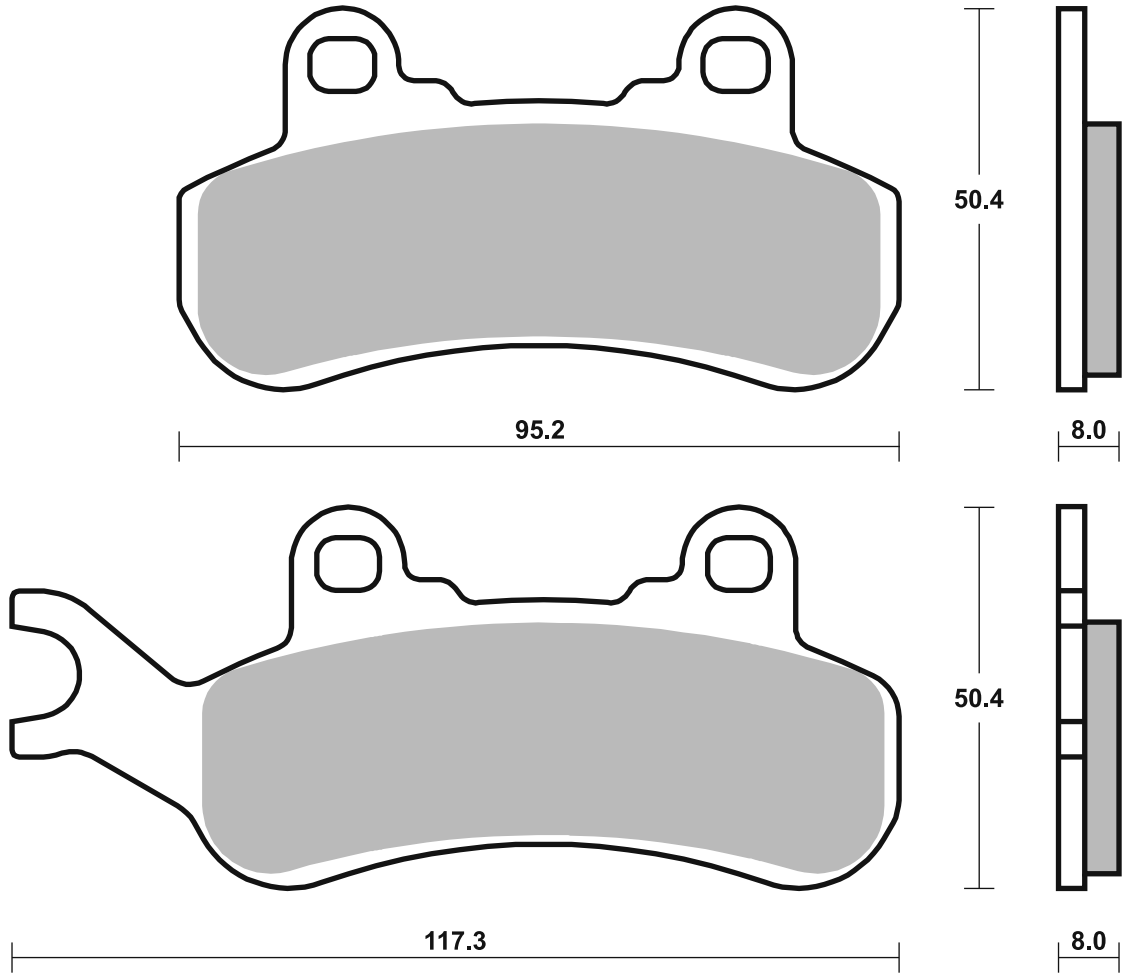



STREET  
AMERICAN  
SCOOTER

HF • HS • LS  
H.HF • H.CT • H.HS • H.LS  
HF • CT • MS

RACING  
OFF ROAD  
ATV

RST • DC • DCC • DS-1 • DS-2 • RQ  
SI • RSI • CS  
ATS • SI • RSI • PSI

Drawings 1:1

Available compounds

SI • RSI • PSI

SBS 957

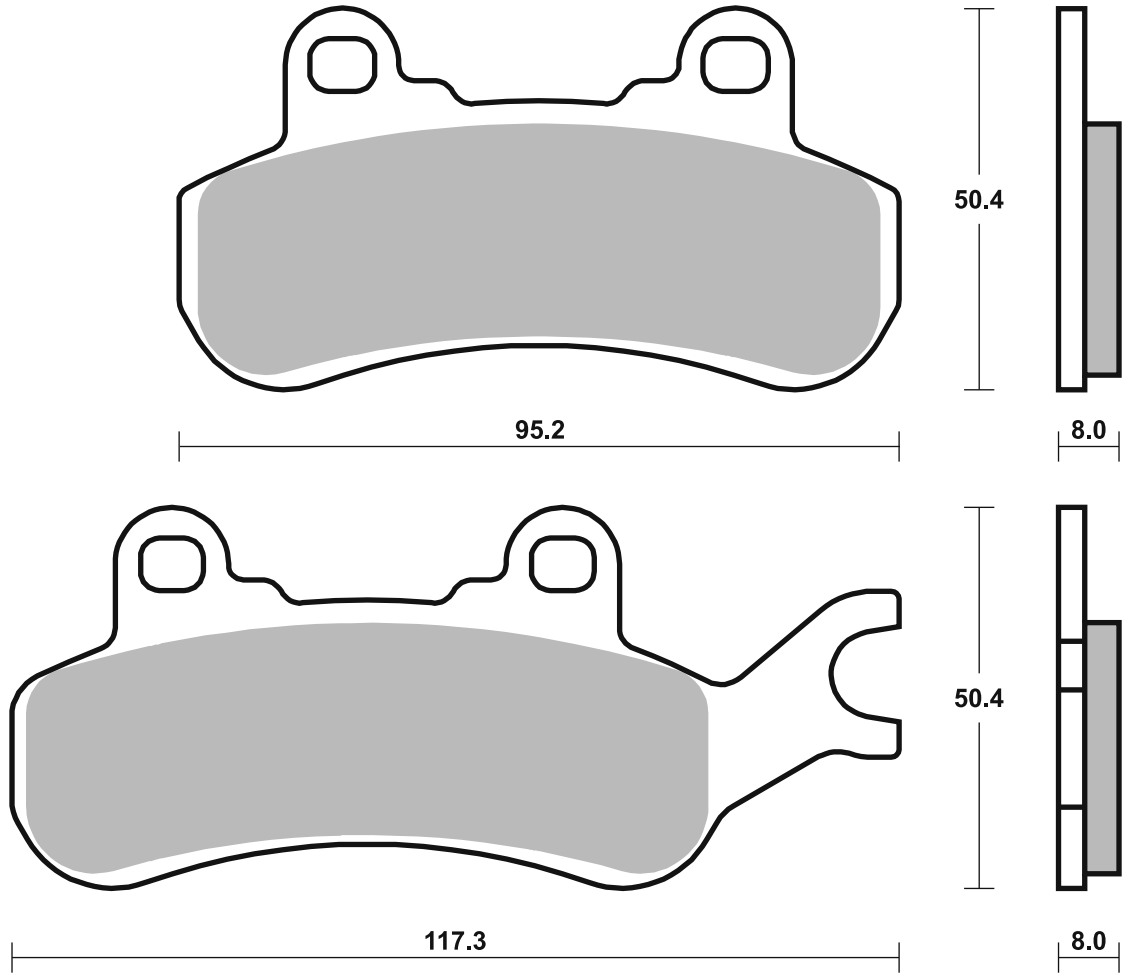

Available compounds

HF

SBS 958

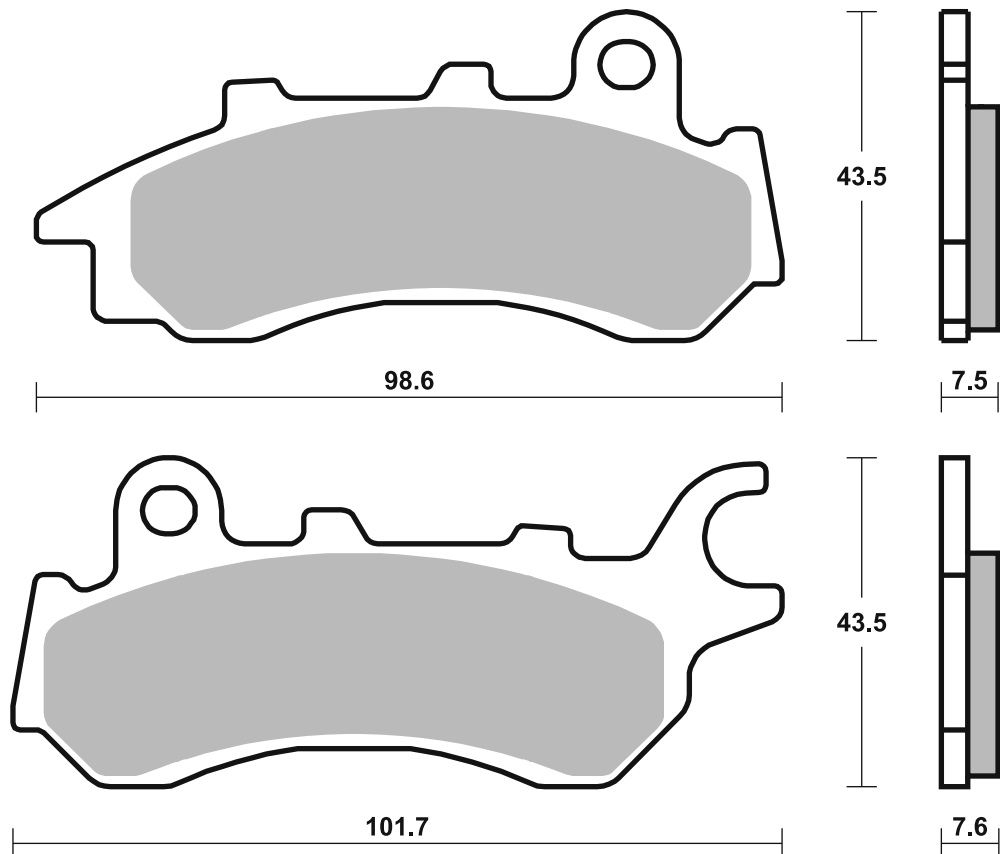

Dimensions in mm / Dimensions en mm  
1" = 25.4 mm, 1 mm = 0.04"

Brake Pad 1:1 Drawings,  
Compounds, Fitments

# Applications

## SBS 959

### Recommended compound



<b>J.JUAN</b>	
Big Brake Kit X3	

## SBS 960

### Recommended compound



<b>BMW</b>		
S 1000 R	20 - 24	<b>HS</b>
S 1000 RR (Hayes cal.)	19 - 21	<b>HS</b>
S 1000 RR ABS	19 - 21	<b>HS</b>
S 1000 XR	20 - 23	<b>HS</b>
R 1250 GS	19 - 23	<b>HS</b>
R 1250 GS Adventure	19 - 24	<b>HS</b>
R 1250 RT	19 - 24	<b>HS</b>
R 1250 RT Sport	19 - 20	<b>HS</b>

Brake Pad 1:1 Drawings,  
Compounds, Fitments



STREET  
AMERICAN  
SCOOTER

HF • HS • LS  
H.HF • H.CT • H.HS • H.LS  
HF • CT • MS

RACING  
OFF ROAD  
ATV

RST • DC • DCC • DS-1 • DS-2 • RQ  
SI • RSI • CS  
ATS • SI • RSI • PSI

Drawings 1:1

Available compounds

PSI

SBS 959

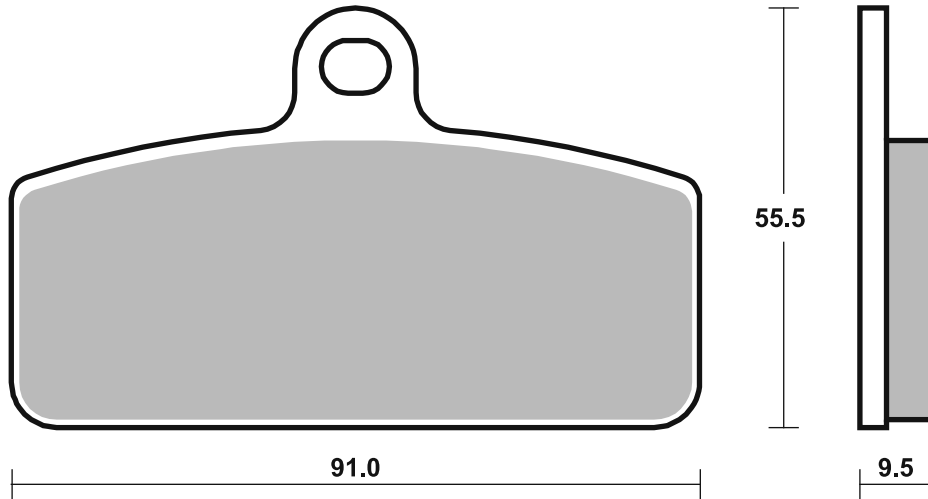

Available compounds

HS • DC • RST • DS-1 • DS-2

SBS 960

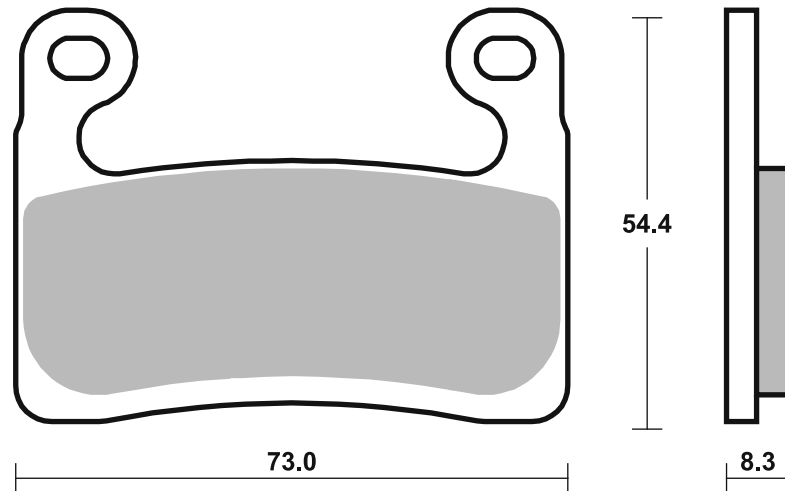

Applications

**SBS 961**

**Recommended compound**



**KEEWAY**

125 Superlight      17 - 19    **HF**

**SBS 962**

**Recommended compound**



**J.JUAN**

Fixed 2p radial caliper 82mm

**OHVALE**

GP-2    190                      21 - 24    **RST**

Brake Pad 1:1 Drawings,  
Compounds, Fitments

STREET  
AMERICAN  
SCOOTER

HF • HS • LS  
H.HF • H.CT • H.HS • H.LS  
HF • CT • MS

RACING  
OFF ROAD  
ATV

RST • DC • DCC • DS-1 • DS-2 • RQ  
SI • RSI • CS  
ATS • SI • RSI • PSI

Drawings 1:1

Available compounds

HF

SBS 961

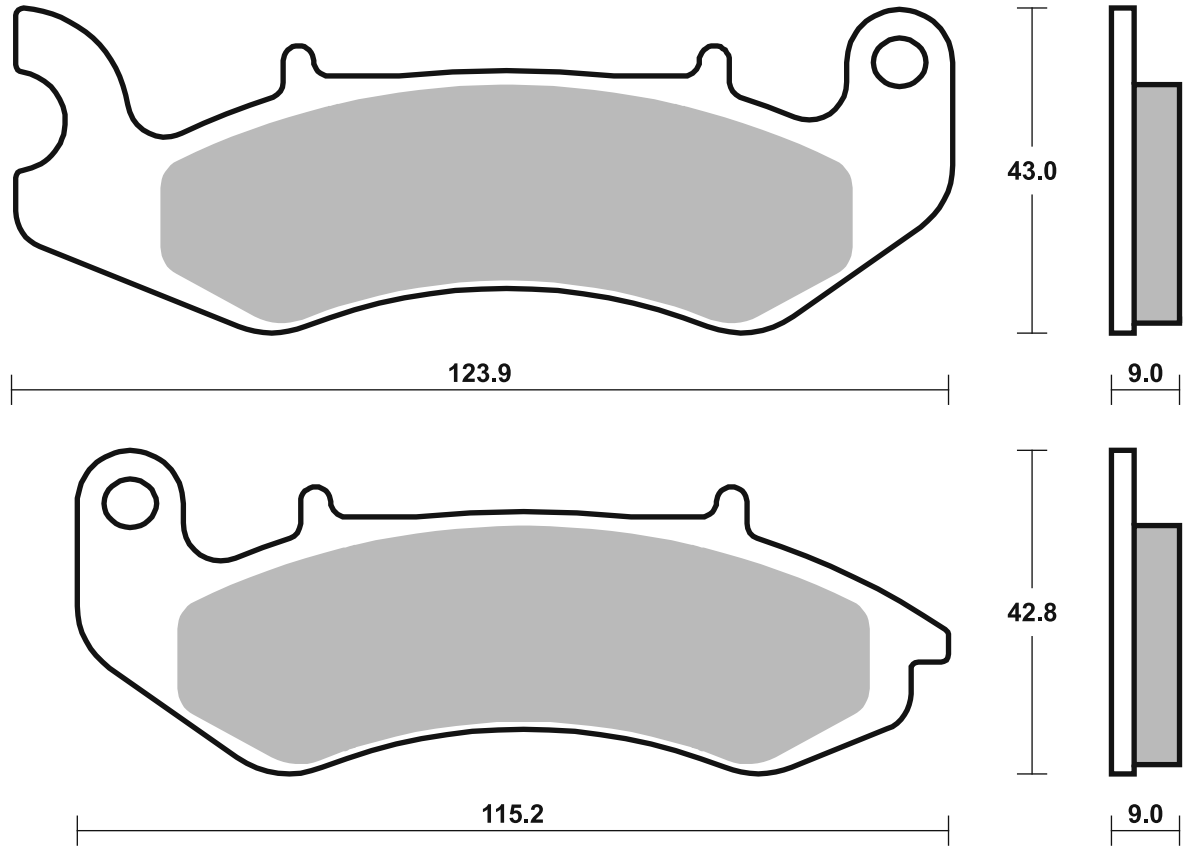

Available compounds

RST

SBS 962

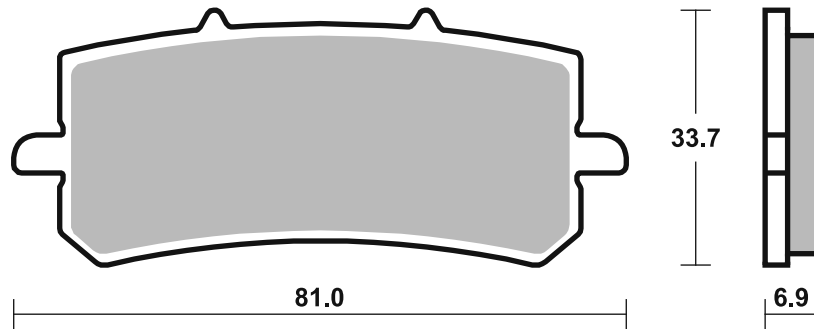

## Applications

### SBS 963

### Recommended compound



#### GASGAS

TXT	125 GP	19 - 23	<b>RSI</b>
TXT	125 Racing	19 - 23	<b>RSI</b>
TXT	250 GP	19 - 23	<b>RSI</b>
TXT	250 Racing	19 - 23	<b>RSI</b>
TXT	280 GP	19 - 23	<b>RSI</b>
TXT	280 Racing	19 - 23	<b>RSI</b>
TXT	300 GP	19 - 23	<b>RSI</b>
TXT	300 Racing	19 - 23	<b>RSI</b>

#### TRS

	125 ONE	19 - 20	<b>RSI</b>
	125 RR ONE	19 - 20	<b>RSI</b>
	250 RR ONE	19 - 20	<b>RSI</b>
	280 RR ONE	19 - 20	<b>RSI</b>
	300 RR ONE	19 - 20	<b>RSI</b>

### SBS 965

### Recommended compound



#### FANTIC

XE	125	23 - 23	<b>SI</b>
XX	125	22 - 24	<b>RSI</b>
XEF	250	23 - 23	<b>SI</b>
XX	250	22 - 24	<b>RSI</b>
XXF	250	22 - 24	<b>RSI</b>
XE	300	24 - 24	<b>SI</b>
XEF	450	22 - 23	<b>SI</b>
XEF	450 Rally	23 - 23	<b>SI</b>
XXF	450	22 - 24	<b>RSI</b>

#### YAMAHA

YZ	125	22 - 24	<b>RSI</b>
WR	250 F Efi	22 - 24	<b>SI</b>
YZ	250	22 - 24	<b>RSI</b>
YZ	250 F	21 - 24	<b>RSI</b>
WR	450 F	21 - 24	<b>SI</b>
YZ	450 F	20 - 24	<b>RSI</b>
YZ	450 FX	21 - 22	<b>SI</b>

STREET  
AMERICAN  
SCOOTER

HF • HS • LS  
H.HF • H.CT • H.HS • H.LS  
HF • CT • MS

RACING  
OFF ROAD  
ATV

RST • DC • DCC • DS-1 • DS-2 • RQ  
SI • RSI • CS  
ATS • SI • RSI • PSI

Drawings 1:1

Available compounds

HF • RSI

SBS 963

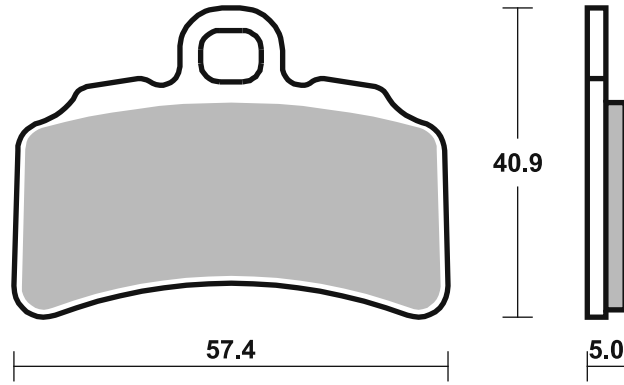

Available compounds

SI • RSI

SBS 965

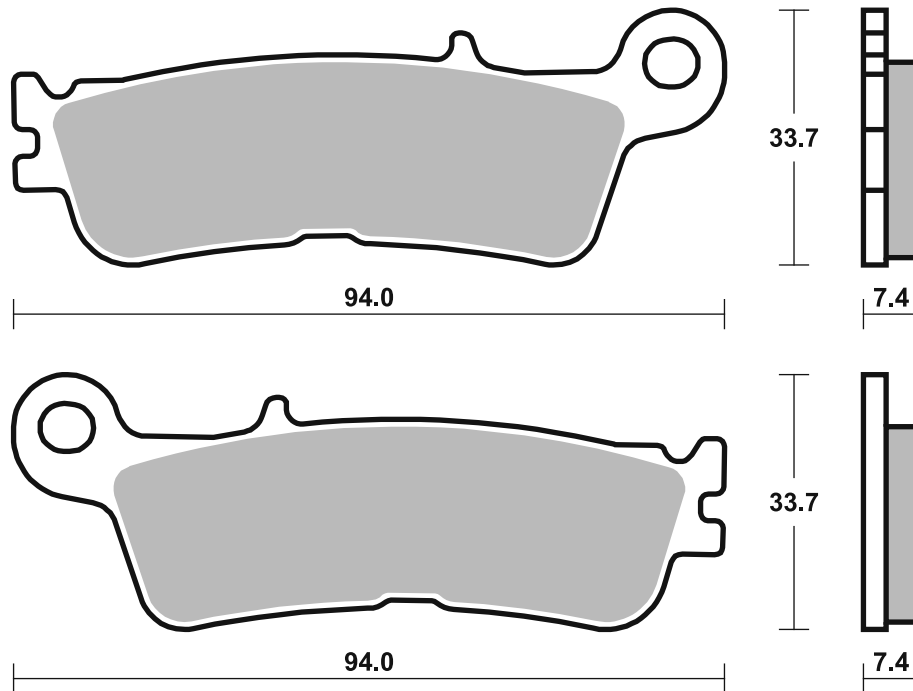



STREET  
AMERICAN  
SCOOTER

HF • HS • LS  
H.HF • H.CT • H.HS • H.LS  
HF • CT • MS

RACING  
OFF ROAD  
ATV

RST • DC • DCC • DS-1 • DS-2 • RQ  
SI • RSI • CS  
ATS • SI • RSI • PSI

Drawings 1:1

Available compounds

DS-1 • DS-2

SBS 966

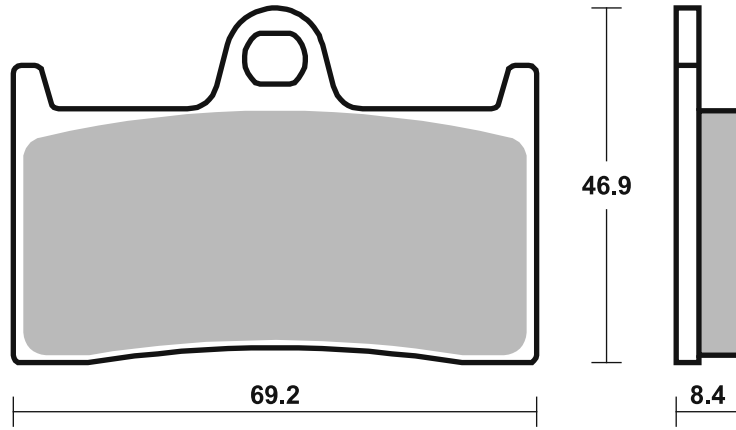

Available compounds

HF

SBS 968

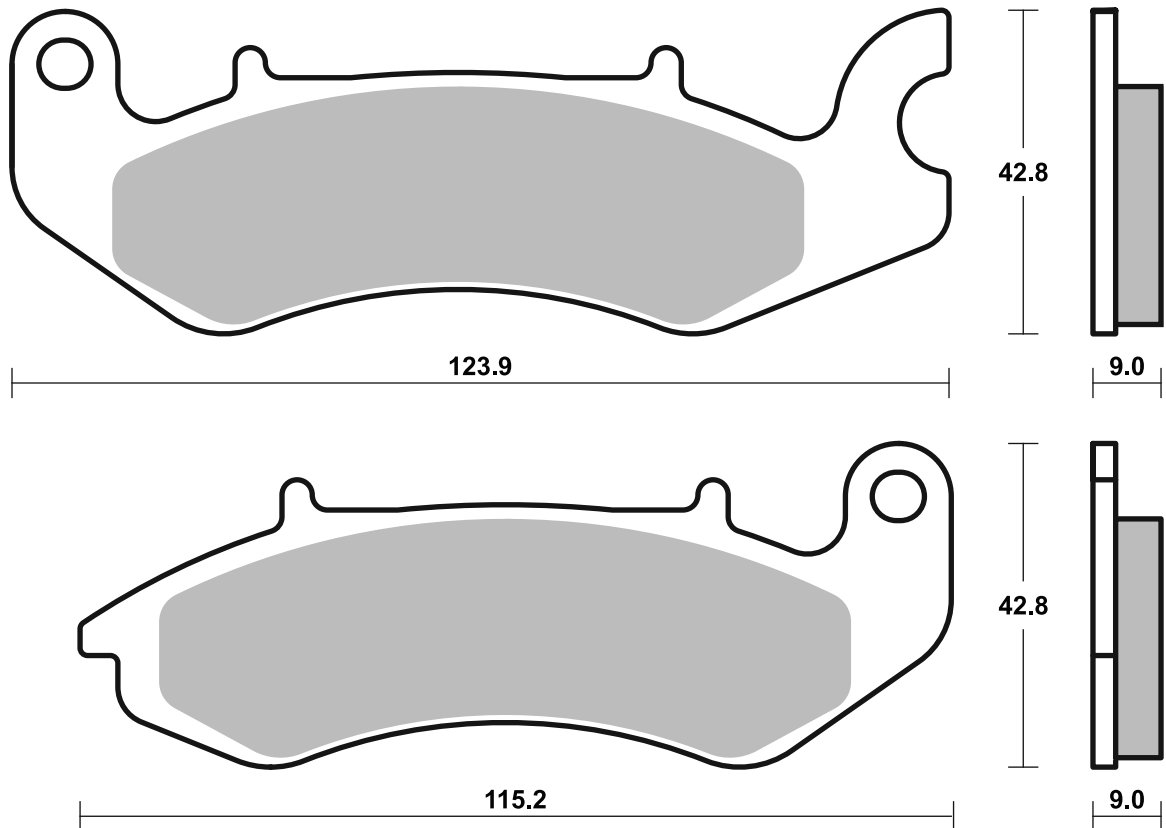





STREET  
AMERICAN  
SCOOTER

HF • HS • LS  
H.HF • H.CT • H.HS • H.LS  
HF • CT • MS

RACING  
OFF ROAD  
ATV

RST • DC • DCC • DS-1 • DS-2 • RQ  
SI • RSI • CS  
ATS • SI • RSI • PSI

Drawings 1:1

Available compounds

SI • RSI • PSI

SBS 970

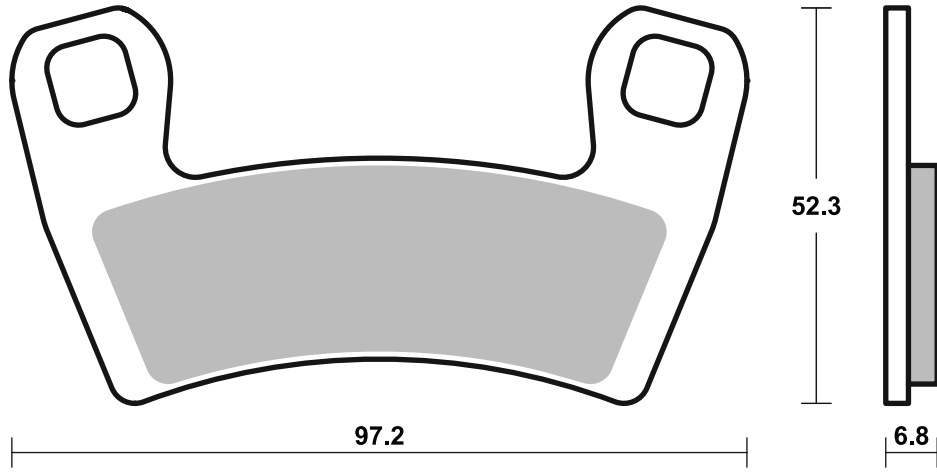

Available compounds

SI • RSI • PSI

SBS 971

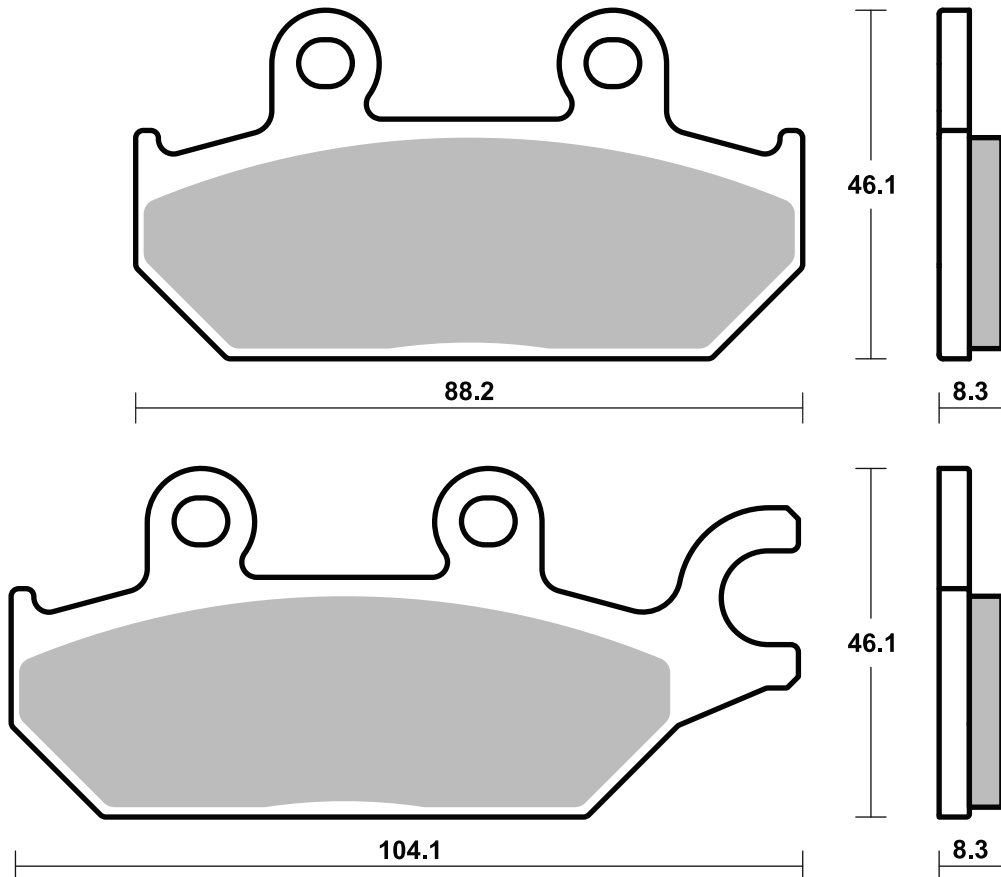

Dimensions in mm / Dimensions en mm  
1" = 25.4 mm, 1 mm = 0.04"

Brake Pad 1:1 Drawings,  
Compounds, Fitments

## Applications

### SBS 972

### Recommended compound



<b>CAN-AM</b>			
800 Commander			
MAX R EFI	18 - 20	<b>PSI</b>	
800 Commander R EFI	18 - 18	<b>PSI</b>	
1000 Commander	16 - 17	<b>PSI</b>	
1000 Commander MAX	14 - 17	<b>PSI</b>	
1000 Commander			
MAX R EFI	18 - 19	<b>PSI</b>	
1000 Commander R EFI	18 - 20	<b>PSI</b>	
1000 Maverick	14 - 18	<b>PSI</b>	
1000 Maverick MAX	14 - 18	<b>PSI</b>	
<b>YAMAHA</b>			
YXC 700 Viking VI	15 - 16	<b>PSI</b>	
YXC 700 Viking VI EPS	15 - 21	<b>PSI</b>	
YXC 700 Viking VI EPS			
Special Edition	16 - 17	<b>PSI</b>	
YXE 700 Wolverine	16 - 18	<b>PSI</b>	
YXE 700 Wolverine EPS	17 - 17	<b>PSI</b>	
YXE 700 Wolverine R-Spec	16 - 16	<b>PSI</b>	
YXE 700 Wolverine R-Spec			
EPS	16 - 18	<b>PSI</b>	
YXE 700 Wolverine R-Spec			
EPS SE	16 - 16	<b>PSI</b>	
YXE 700 Wolverine R-Spec			
EPS Special			
Edition	17 - 17	<b>PSI</b>	
YXM 700 Viking	14 - 20	<b>PSI</b>	
YXM 700 Viking EPS	14 - 21	<b>PSI</b>	
YXM 700 Viking EPS SE	14 - 17	<b>PSI</b>	
YXM 700 Viking EPS Special			
E	19 - 19	<b>PSI</b>	



<b>YAMAHA</b>			
YXM 700 Viking EPS Special			
Edition	16 - 16	<b>PSI</b>	
YXE 850 Wolverine X2	19 - 19	<b>PSI</b>	
YXE 850 Wolverine X2 EPS	20 - 20	<b>PSI</b>	
YXE 850 Wolverine X2			
R-Spec	19 - 20	<b>PSI</b>	
YXE 850 Wolverine X2 XTR	20 - 20	<b>PSI</b>	
YXF 850 Wolverine X4	18 - 20	<b>PSI</b>	
YXF 850 Wolverine X4 SE	19 - 19	<b>PSI</b>	
YXF 850 Wolverine X4			
Special	19 - 19	<b>PSI</b>	
YXF 850 Wolverine X4			
Special Edition	18 - 18	<b>PSI</b>	
YXF 850 Wolverine X4 XTR	20 - 20	<b>PSI</b>	

### SBS 973

### Recommended compound



<b>YAMAHA</b>			
YXC 700 Viking VI	15 - 16	<b>PSI</b>	
YXC 700 Viking VI EPS	15 - 21	<b>PSI</b>	
YXC 700 Viking VI EPS			
Special Edition	16 - 17	<b>PSI</b>	
YXE 700 Wolverine	16 - 18	<b>PSI</b>	
YXE 700 Wolverine EPS	17 - 17	<b>PSI</b>	
YXE 700 Wolverine R-Spec	16 - 16	<b>PSI</b>	
YXE 700 Wolverine R-Spec			
EPS	16 - 18	<b>PSI</b>	
YXE 700 Wolverine R-Spec			
EPS SE	16 - 16	<b>PSI</b>	
YXE 700 Wolverine R-Spec			
EPS Special Edition	17 - 17	<b>PSI</b>	
YXM 700 Viking	14 - 20	<b>PSI</b>	
YXM 700 Viking EPS	14 - 21	<b>PSI</b>	
YXM 700 Viking EPS SE	14 - 17	<b>PSI</b>	
YXM 700 Viking EPS Special			
E	19 - 19	<b>PSI</b>	
YXM 700 Viking EPS Special			
Edition	16 - 16	<b>PSI</b>	
YXE 850 Wolverine X2	19 - 19	<b>PSI</b>	
YXE 850 Wolverine X2 EPS	20 - 20	<b>PSI</b>	
YXE 850 Wolverine X2			
R-Spec	19 - 20	<b>PSI</b>	
YXE 850 Wolverine X2 XTR	20 - 20	<b>PSI</b>	
YXF 850 Wolverine X4	18 - 20	<b>PSI</b>	
YXF 850 Wolverine X4 SE	19 - 19	<b>PSI</b>	
YXF 850 Wolverine X4			
Special	19 - 19	<b>PSI</b>	
YXF 850 Wolverine X4			
Special Edition	18 - 18	<b>PSI</b>	



<b>YAMAHA</b>			
YXF 850 Wolverine X4 XTR	20 - 20	<b>PSI</b>	

STREET  
AMERICAN  
SCOOTER

HF • HS • LS  
H.HF • H.CT • H.HS • H.LS  
HF • CT • MS

RACING  
OFF ROAD  
ATV

RST • DC • DCC • DS-1 • DS-2 • RQ  
SI • RSI • CS  
ATS • SI • RSI • PSI

Drawings 1:1

Available compounds

SI • RSI • PSI

SBS 972

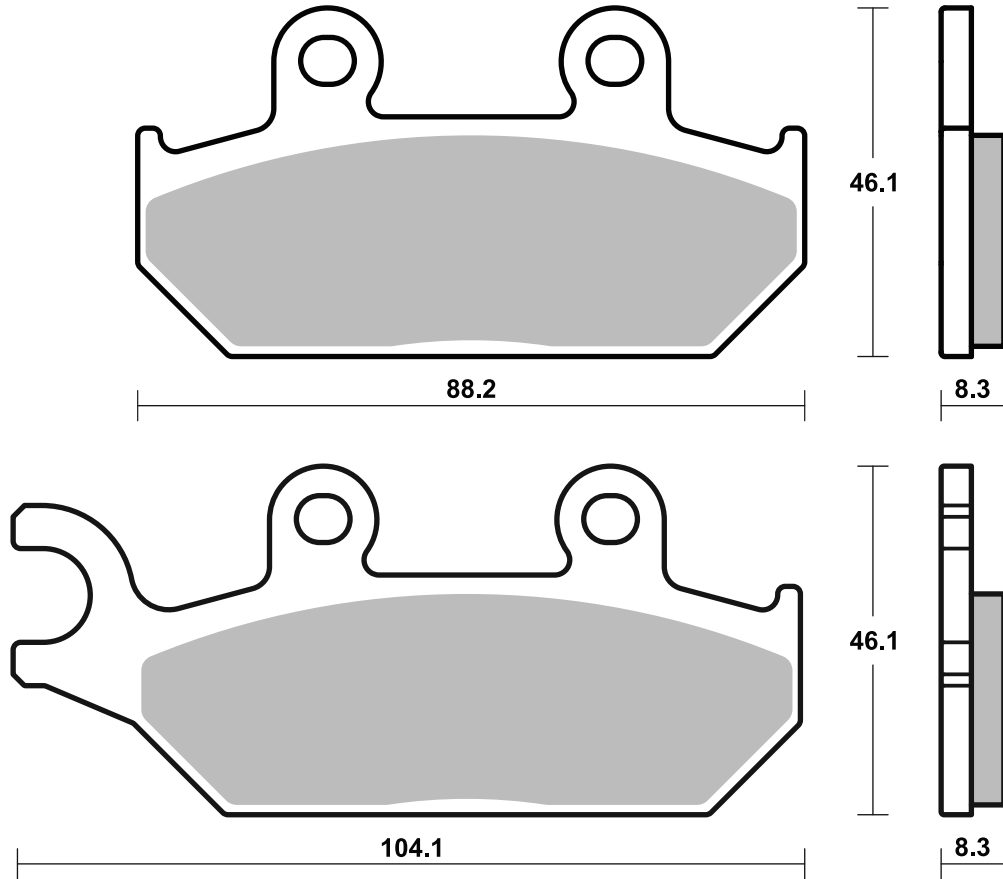

Available compounds

SI • RSI • PSI

SBS 973

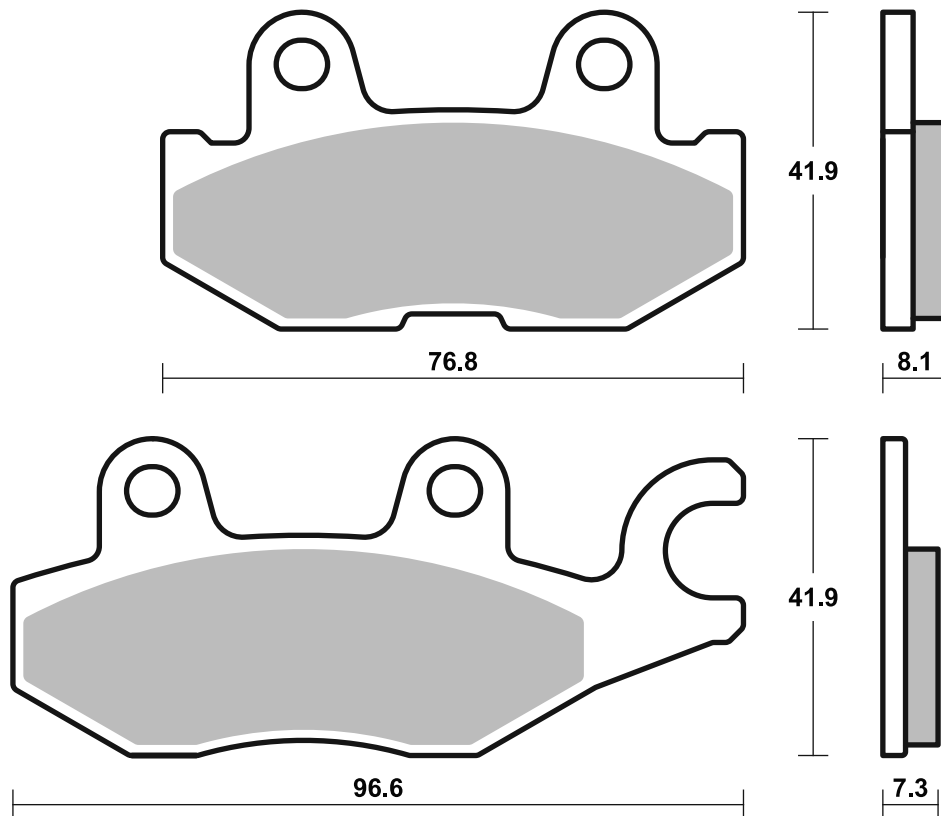



STREET  
AMERICAN  
SCOOTER

HF • HS • LS  
H.HF • H.CT • H.HS • H.LS  
HF • CT • MS

RACING  
OFF ROAD  
ATV

RST • DC • DCC • DS-1 • DS-2 • RQ  
SI • RSI • CS  
ATS • SI • RSI • PSI

Drawings 1:1

Available compounds

SI • RSI • PSI

SBS 974

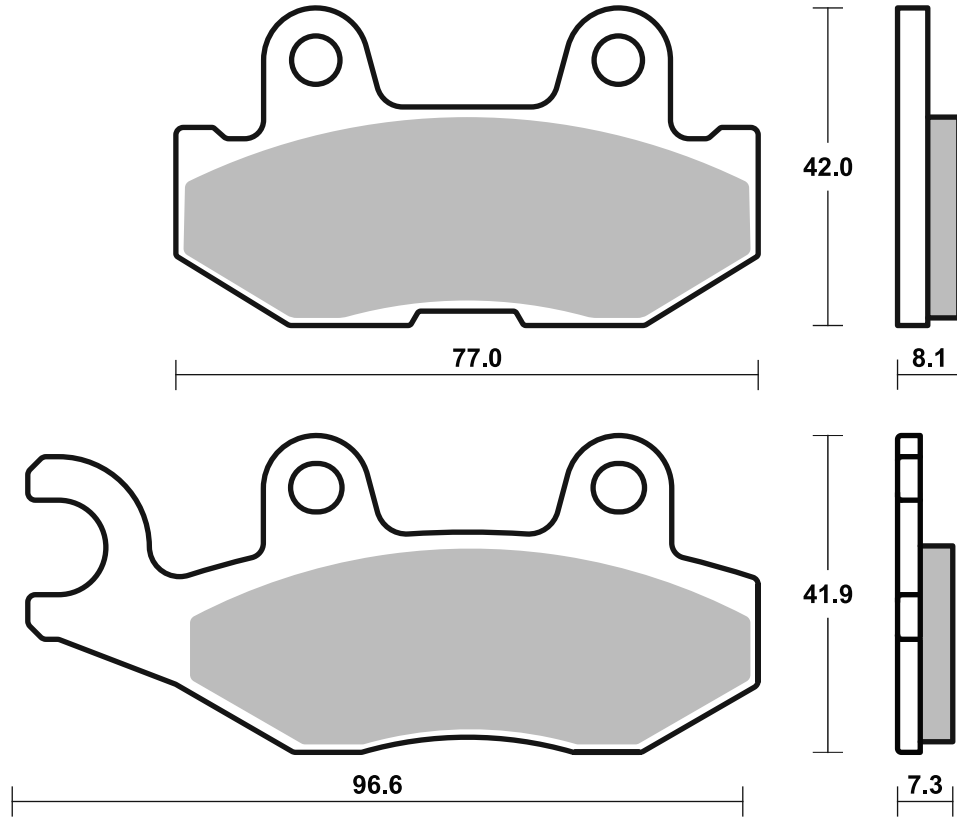

Available compounds

SI • RSI • PSI

SBS 975

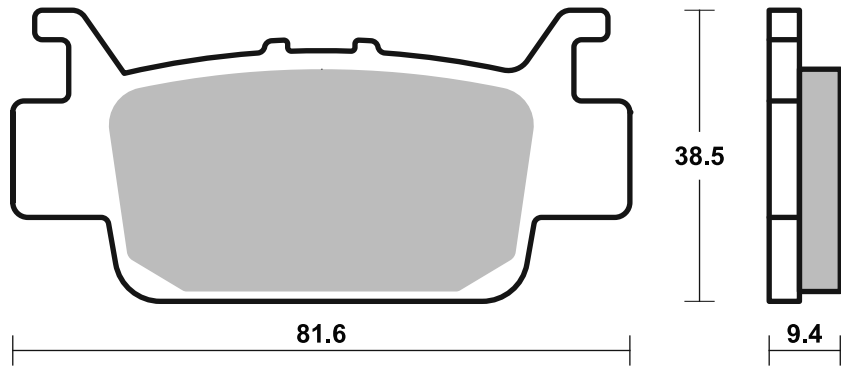

**Applications**

**SBS 976**

**Recommended compound**



<b>HONDA</b>		
500 Pioneer	15 - 20	<b>PSI</b>
700 Pioneer	14 - 21	<b>PSI</b>

**SBS 977**

**Recommended compound**



<b>POLARIS</b>		
925 RZR Pro R	22 - 23	<b>SI</b>
925 RZR Pro R4	22 - 23	<b>SI</b>
925 RZR Turbo R	22 - 23	<b>SI</b>
925 RZR Turbo R4	22 - 23	<b>SI</b>
925 RZR Turbo XP4		
Turbo S	19 - 20	<b>SI</b>
925 RZR XP4 Turbo S	19 - 20	<b>SI</b>
925 RZR XP4 Turbo S		
Velocity	19 - 20	<b>SI</b>

**SBS 978**

**Recommended compound**



<b>POLARIS</b>		
925 RZR Pro R	22 - 23	<b>SI</b>
925 RZR Pro R4	22 - 23	<b>SI</b>
925 RZR Pro XP	20 - 23	<b>SI</b>
925 RZR Pro XP4	20 - 23	<b>SI</b>
925 RZR Turbo R	22 - 23	<b>SI</b>
925 RZR Turbo R4	22 - 23	<b>SI</b>
925 RZR XP Turbo	20 - 21	<b>SI</b>
925 RZR XP4 Turbo	20 - 21	<b>SI</b>

STREET  
AMERICAN  
SCOOTER

HF • HS • LS  
H.HF • H.CT • H.HS • H.LS  
HF • CT • MS

RACING  
OFF ROAD  
ATV

RST • DC • DCC • DS-1 • DS-2 • RQ  
SI • RSI • CS  
ATS • SI • RSI • PSI

Drawings 1:1

Available compounds

SI • RSI • PSI

SBS 976

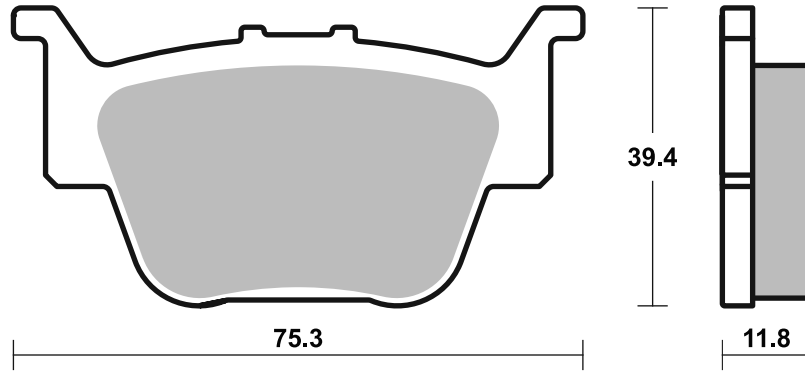

Available compounds

SI • RSI

SBS 977

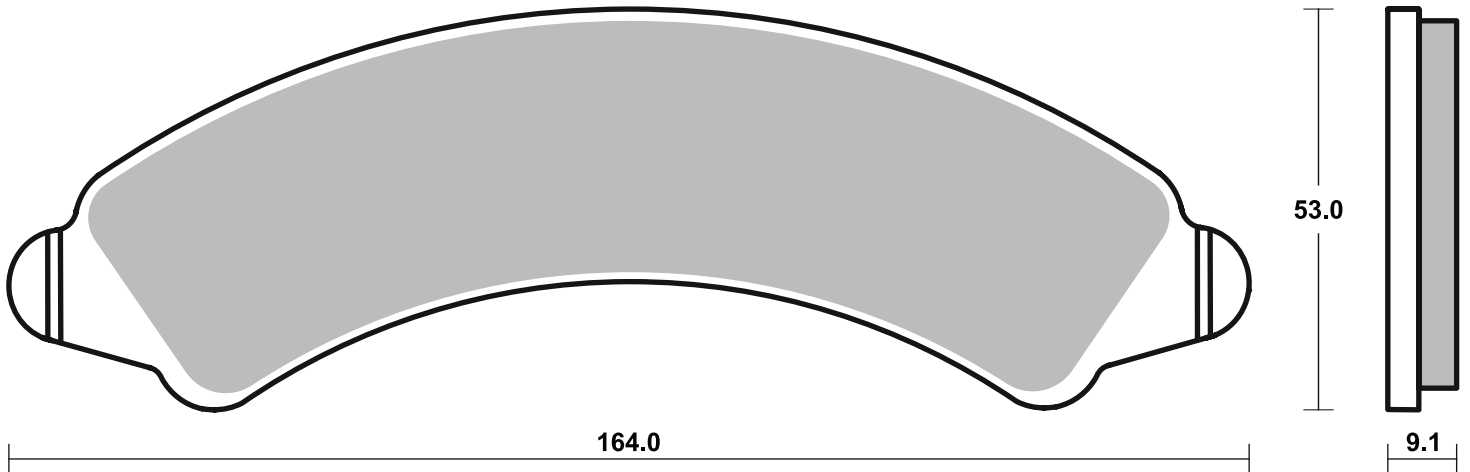

Available compounds

SI • RSI • PSI

SBS 978

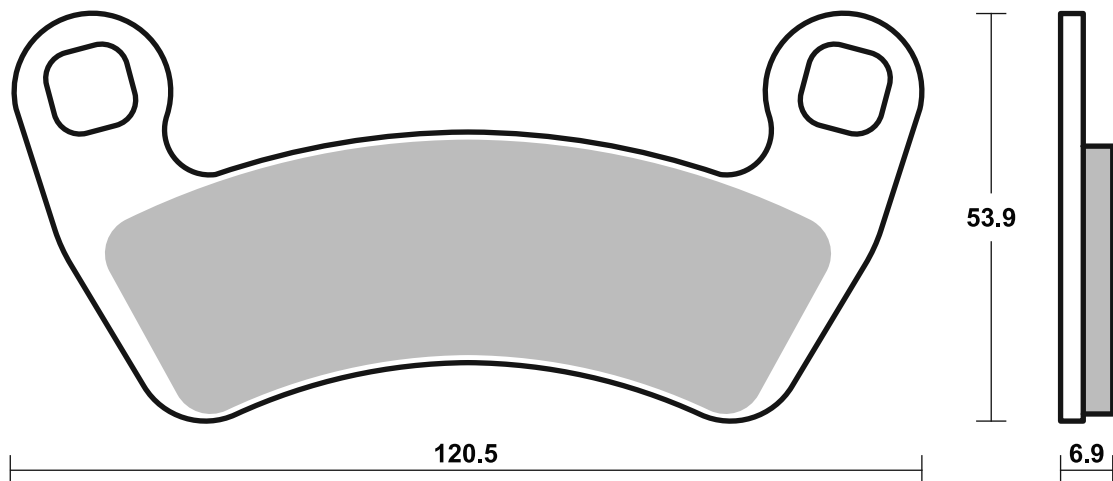

## Applications

### SBS 979 Recommended compound



<b>YAMAHA</b>			
	1000 Wolverine RMAX 4	21 -21	<b>PSI</b>
	1000 Wolverine RMAX 4		
	LE	21 -21	<b>PSI</b>
	1000 Wolverine RMAX 4		
	SE	21 -21	<b>PSI</b>
YXE	1000	21 -21	<b>PSI</b>
YXZ	1000 EPS	16 -20	<b>PSI</b>
YXZ	1000 EPS SE	17 -19	<b>PSI</b>
YXZ	1000 EPS Special	20 -20	<b>PSI</b>
YXZ	1000 EPS Special Edition	16 -17	<b>PSI</b>
YXZ	1000 EPS SS	17 -20	<b>PSI</b>
YXZ	1000 SS Special	20 -20	<b>PSI</b>
YXZ	1000 SS XTR	20 -20	<b>PSI</b>

### SBS 980 Recommended compound



<b>YAMAHA</b>			
	1000 Wolverine RMAX 4	21 -21	<b>PSI</b>
	1000 Wolverine RMAX 4		
	LE	21 -21	<b>PSI</b>
	1000 Wolverine RMAX 4		
	SE	21 -21	<b>PSI</b>
YXE	1000	21 -21	<b>PSI</b>
YXZ	1000 EPS	16 -20	<b>PSI</b>
YXZ	1000 EPS SE	17 -19	<b>PSI</b>
YXZ	1000 EPS Special	20 -20	<b>PSI</b>
YXZ	1000 EPS Special Edition	16 -17	<b>PSI</b>
YXZ	1000 EPS SS	17 -20	<b>PSI</b>
YXZ	1000 SS Special	20 -20	<b>PSI</b>
YXZ	1000 SS XTR	20 -20	<b>PSI</b>

### SBS 981 Recommended compound



<b>HONDA</b>			
	1000 Pioneer	16 -21	<b>PSI</b>
	1000 Talon	21 -21	<b>PSI</b>
	1000 Talon R	19 -21	<b>PSI</b>
	1000 Talon X	19 -21	<b>PSI</b>
	1000 Talon X-4	20 -20	<b>PSI</b>

Brake Pad 1:1 Drawings,  
Compounds, Fitments



STREET  
AMERICAN  
SCOOTER

HF • HS • LS  
H.HF • H.CT • H.HS • H.LS  
HF • CT • MS

RACING  
OFF ROAD  
ATV

RST • DC • DCC • DS-1 • DS-2 • RQ  
SI • RSI • CS  
ATS • SI • RSI • PSI

Drawings 1:1

Available compounds

SI • RSI • PSI

SBS 979

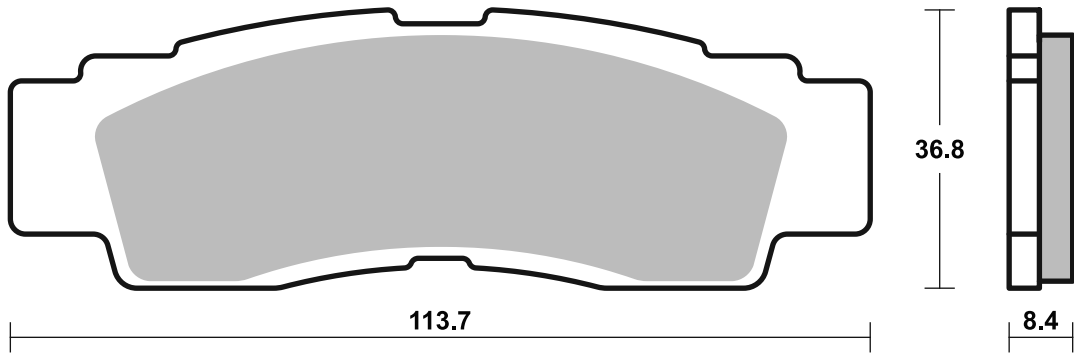

Available compounds

SI • RSI • PSI

SBS 980

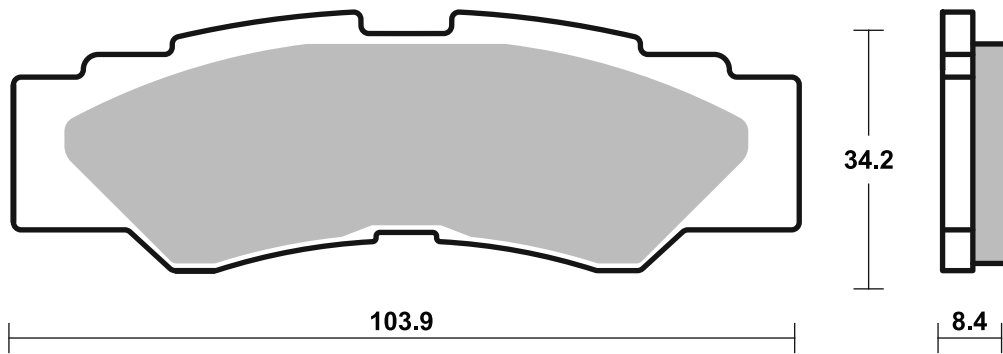

Available compounds

SI • RSI • PSI

SBS 981

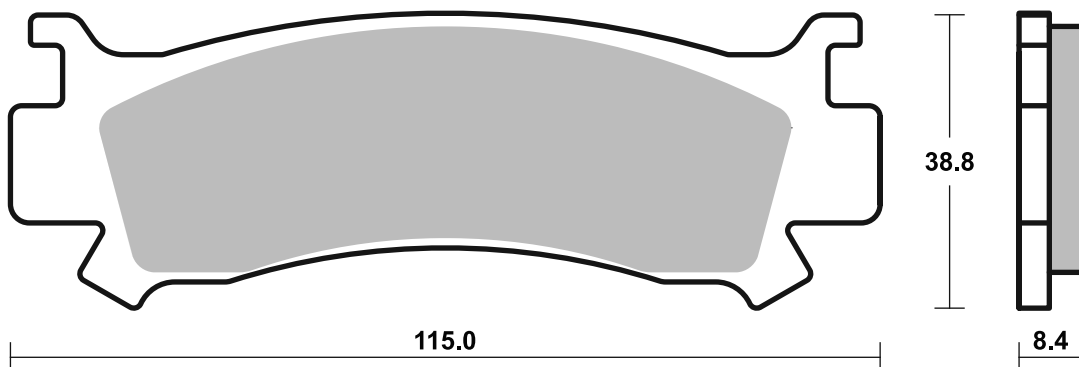



STREET  
AMERICAN  
SCOOTER

HF • HS • LS  
H.HF • H.CT • H.HS • H.LS  
HF • CT • MS

RACING  
OFF ROAD  
ATV

RST • DC • DCC • DS-1 • DS-2 • RQ  
SI • RSI • CS  
ATS • SI • RSI • PSI

Drawings 1:1

Available compounds

SI • RSI • PSI

SBS 982

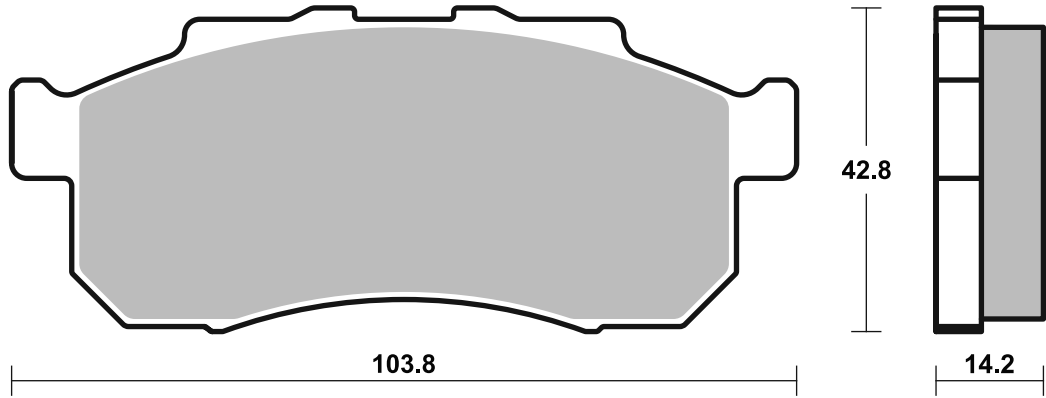

Available compounds

HS

SBS 983

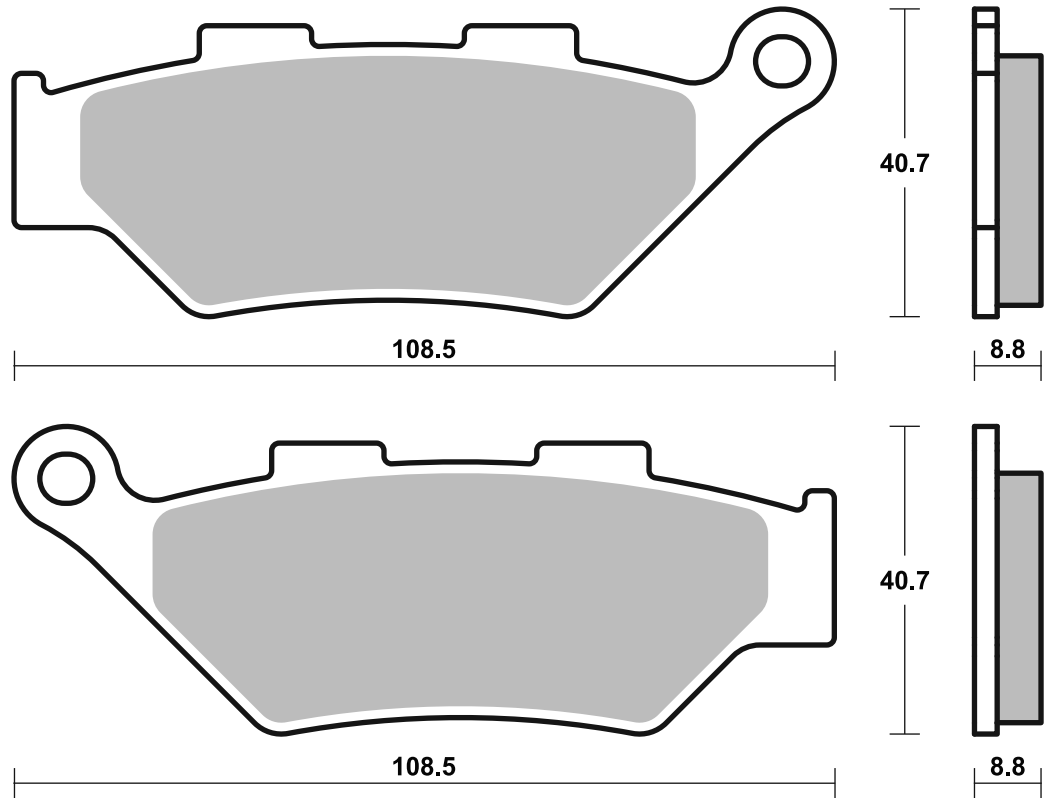

Applications

**SBS 984 Recommended compound**



<b>BMW</b>			
M	1000 RR	21 - 24	<b>LS</b>

**SBS 985 Recommended compound**



<b>BMW</b>			
M	1000 R	23 - 24	<b>HS</b>
M	1000 RR	21 - 24	<b>HS</b>
S	1000 RR (Nissin cal.)	21 - 24	<b>HS</b>

<b>HONDA</b>			
CBR	1000 RR-R Fireblade	20 - 23	<b>HS</b>

**SBS 986 Recommended compound**



<b>CF MOTO</b>			
	400 C-Force	18 - 21	<b>PSI</b>
	500 C-Force HO	18 - 18	<b>PSI</b>
	500 C-Force S	18 - 21	<b>PSI</b>
	500 U-Force	18 - 20	<b>PSI</b>
	500 Z-Force	18 - 21	<b>PSI</b>
	520 C-Force L	16 - 23	<b>PSI</b>
	520 C-Force S	16 - 21	<b>PSI</b>
	600 C-Force	19 - 21	<b>PSI</b>
	600 C-Force Touring	20 - 21	<b>PSI</b>
	800 U-Force	18 - 21	<b>PSI</b>
	800 Z-Force EX	18 - 21	<b>PSI</b>
	800 Z-Force Trail	18 - 21	<b>PSI</b>
	1000 Z-Force	18 - 19	<b>PSI</b>

Brake Pad 1:1 Drawings,  
Compounds, Fitments

STREET  
AMERICAN  
SCOOTER

HF • HS • LS  
H.HF • H.CT • H.HS • H.LS  
HF • CT • MS

RACING  
OFF ROAD  
ATV

RST • DC • DCC • DS-1 • DS-2 • RQ  
SI • RSI • CS  
ATS • SI • RSI • PSI

Drawings 1:1

Available compounds

LS • RQ

SBS 984

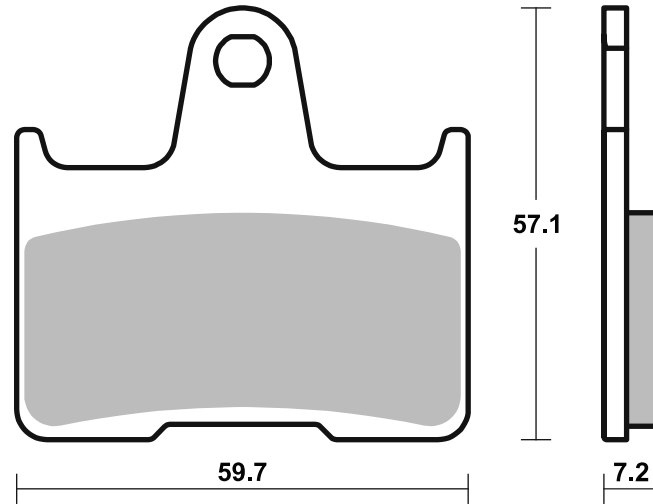

Available compounds

HS • DC • RST • DS-1 • DS-2

SBS 985

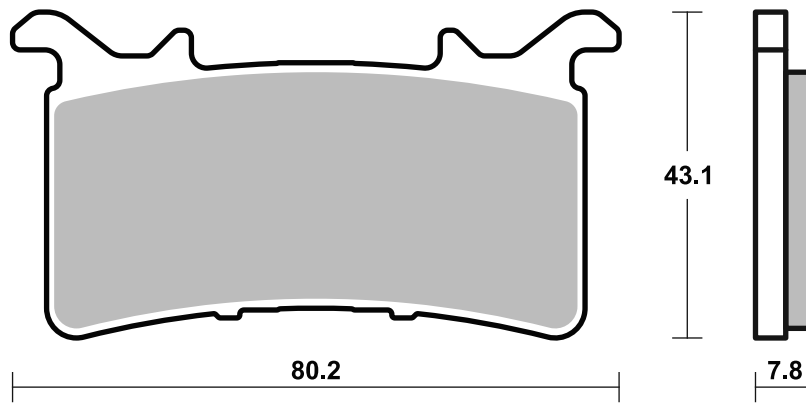

Available compounds

SI • PSI

SBS 986

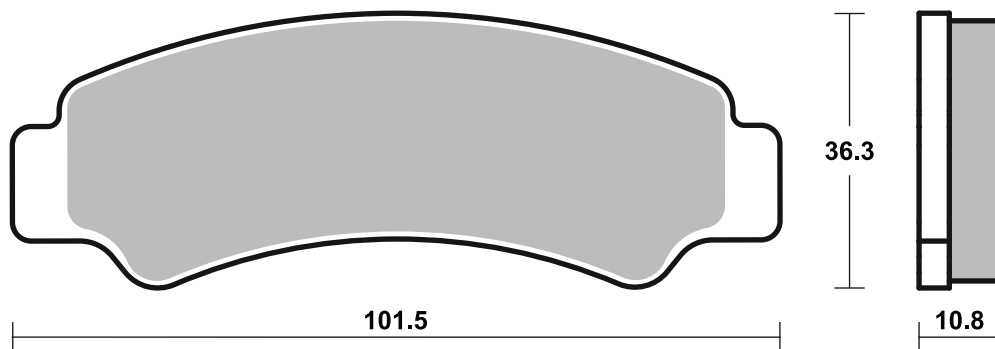

# Applications

## SBS 987

### Recommended compound



<b>CF MOTO</b>			
500 U-Force	18 - 20		<b>PSI</b>
500 Z-Force	18 - 21		<b>PSI</b>
520 C-Force L	16 - 23		<b>PSI</b>
520 C-Force S	16 - 21		<b>PSI</b>
600 C-Force	20 - 21		<b>PSI</b>
600 C-Force Touring	20 - 21		<b>PSI</b>
800 U-Force	18 - 21		<b>PSI</b>
800 Z-Force EX	18 - 21		<b>PSI</b>
800 Z-Force Trail	18 - 21		<b>PSI</b>
1000 Z-Force	18 - 19		<b>PSI</b>

## SBS 991

### Recommended compound



<b>YAMAHA</b>			
MXT	850 Niken	18 - 24	<b>LS</b>
MXT	850 Niken GT	19 - 24	<b>LS</b>

Brake Pad 1:1 Drawings, Compounds, Fittings

STREET  
AMERICAN  
SCOOTER

HF • HS • LS  
H.HF • H.CT • H.HS • H.LS  
HF • CT • MS

RACING  
OFF ROAD  
ATV

RST • DC • DCC • DS-1 • DS-2 • RQ  
SI • RSI • CS  
ATS • SI • RSI • PSI

Drawings 1:1

Available compounds

SI • PSI

SBS 987

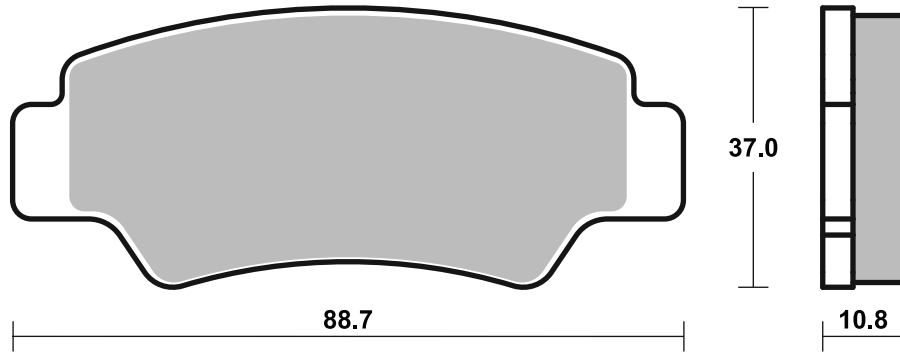

Available compounds

LS

SBS 991

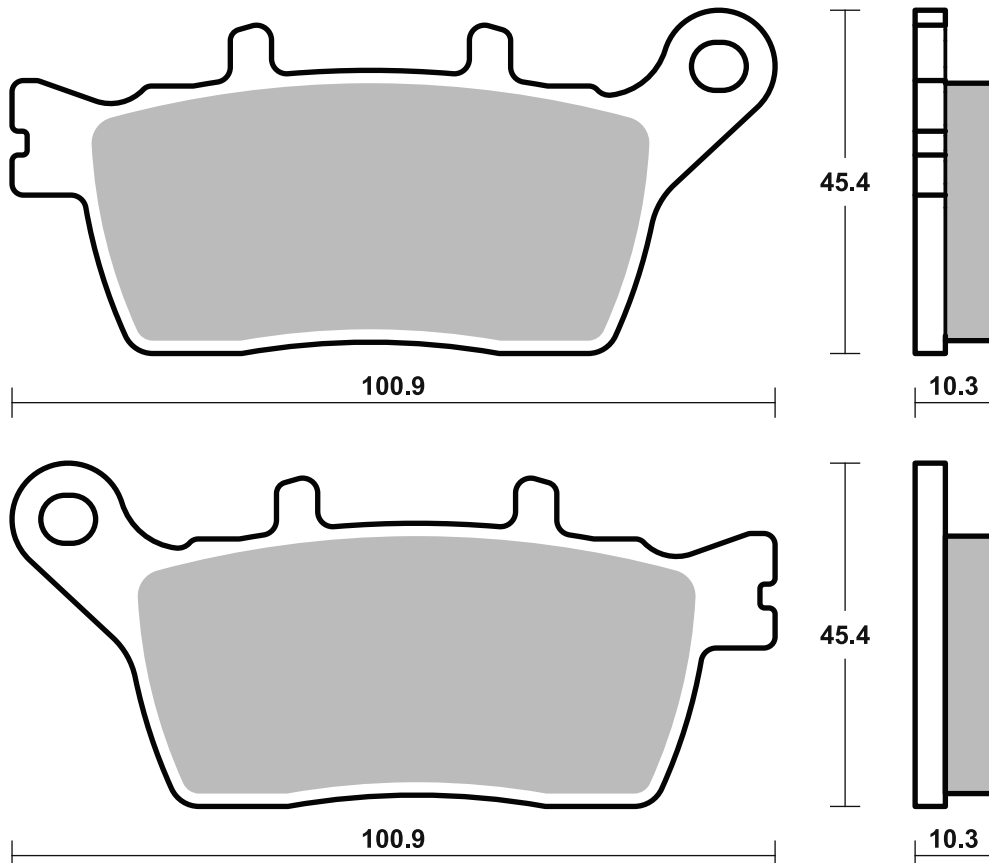

# Applications

## SBS 993 Recommended compound



### HARLEY DAVIDSON

S2	Del Mar	24 - 24	<b>H.LS</b>
S2	Del Mar LE	24 - 24	<b>H.LS</b>
RH	975 Nightster	22 - 23	<b>H.LS</b>
RH	1250 Sportster S	21 - 23	<b>H.LS</b>

### LIVEWIRE

S2	Del Mar	24 - 24	<b>H.LS</b>
S2	Del Mar LE	24 - 24	<b>H.LS</b>

## SBS 994 Recommended compound



### HONDA

CB	500 F	22 - 24	<b>HS</b>
CB	500 Hornet	24 - 24	<b>HS</b>
CB	500 X	22 - 24	<b>HS</b>
CBR	500 R	22 - 24	<b>HS</b>
CB	750 Hornet	23 - 24	<b>HS</b>

Brake Pad 1:1 Drawings, Compounds, Fitments



STREET  
AMERICAN  
SCOOTER

HF • HS • LS  
H.HF • H.CT • H.HS • H.LS  
HF • CT • MS

RACING  
OFF ROAD  
ATV

RST • DC • DCC • DS-1 • DS-2 • RQ  
SI • RSI • CS  
ATS • SI • RSI • PSI

Drawings 1:1

Available compounds

H.LS

SBS 993

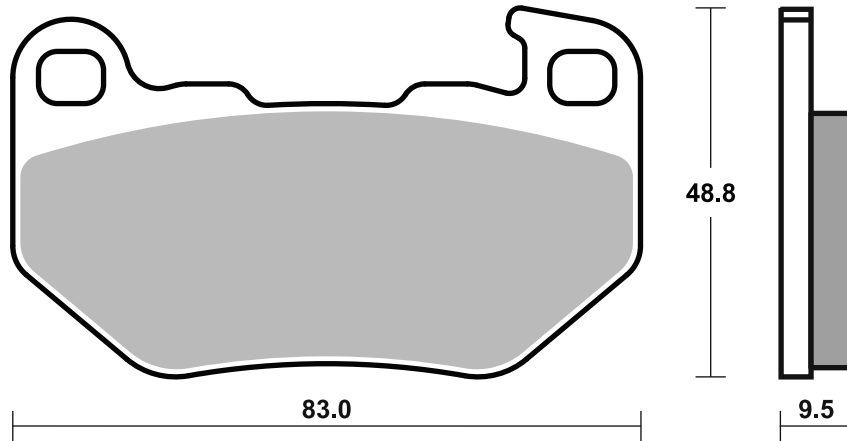

Available compounds

HS

SBS 994

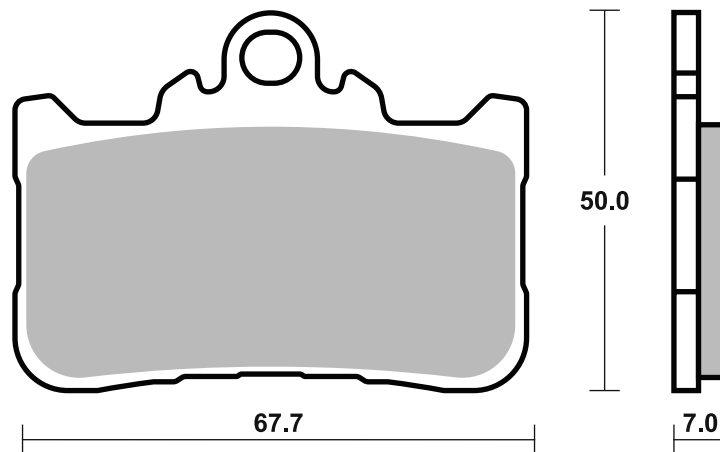

# Applications

## SBS 995

### Recommended compound



#### BMW

R18	1800	21 -24	HS	LS
R18	1800 100 Years	24 -24	HS	LS
R18	1800 B	22 -24	HS	LS
R18	1800 Classic	21 -24	HS	LS
R18	1800 Roctane	24 -24	HS	LS
R18	1800 Transcontinental	22 -24	HS	LS

## SBS 998

### Recommended compound



#### SWM

	125 Outlaw	20 -20	HF	
	125 Varez	20 -20	HF	
RS	125 R	18 -20	HF	
SM	125 R	18 -20	HF	
	440 Gran Milano	15 -18	HF	
	440 Gran Turismo	15 -17	HF	
	440 Silver Vase	15 -17	HF	
	500 Ace of Spades	18 -21	HF	
	500 Gran Milano			
	Outlaw	18 -21	HF	

Brake Pad 1:1 Drawings,  
Compounds, Fitments

STREET  
AMERICAN  
SCOOTER

HF • HS • LS  
H.HF • H.CT • H.HS • H.LS  
HF • CT • MS

RACING  
OFF ROAD  
ATV

RST • DC • DCC • DS-1 • DS-2 • RQ  
SI • RSI • CS  
ATS • SI • RSI • PSI

Drawings 1:1

Available compounds

HS • LS

SBS 995

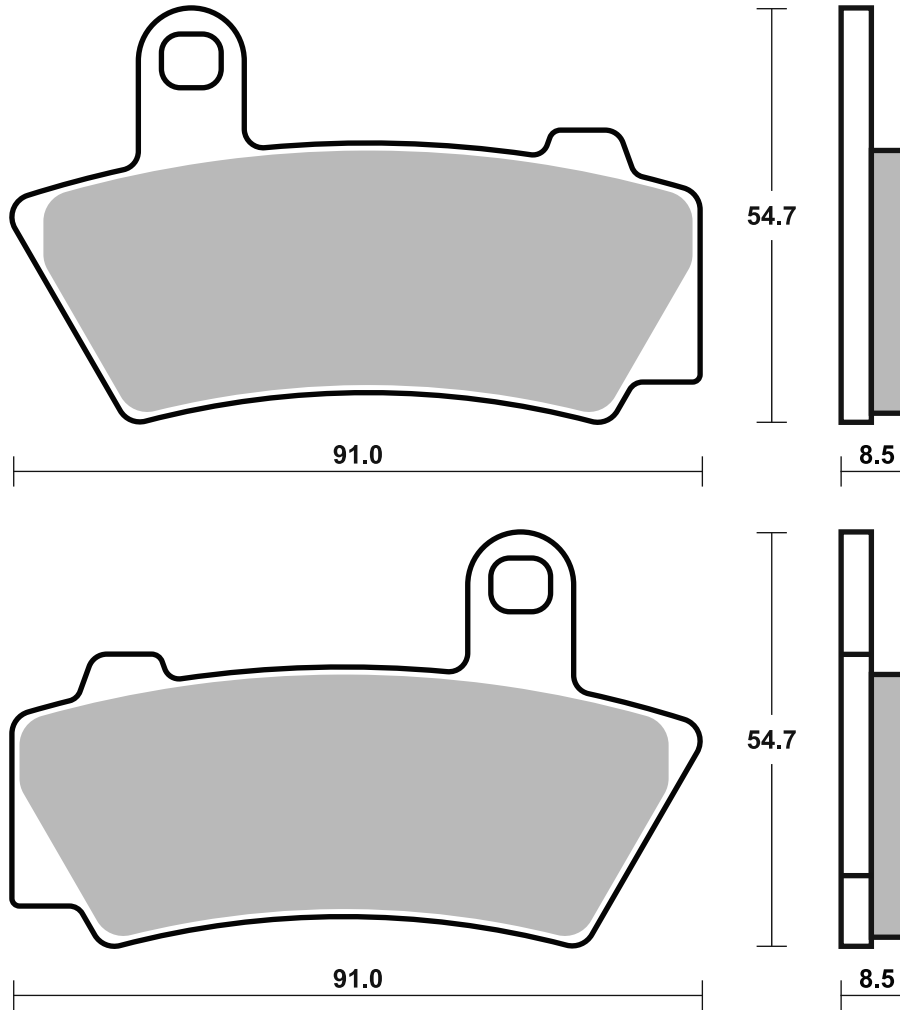

Available compounds

HF

SBS 998

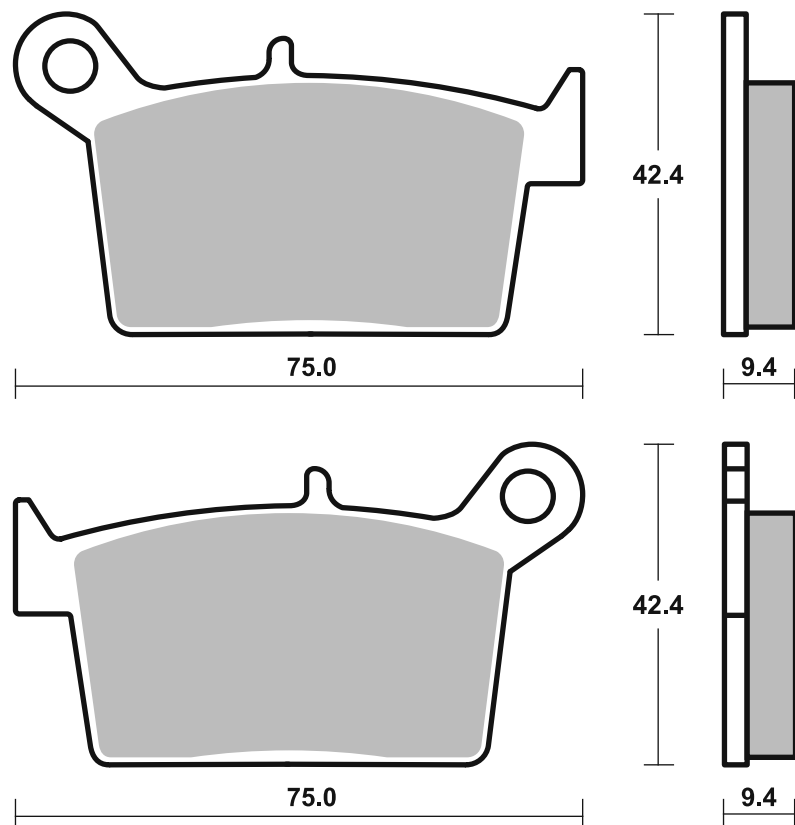

Dimensions in mm / Dimensions en mm  
1" = 25.4 mm, 1 mm = 0.04"



STREET  
AMERICAN  
SCOOTER

HF • HS • LS  
H.HF • H.CT • H.HS • H.LS  
HF • CT • MS

RACING  
OFF ROAD  
ATV

RST • DC • DCC • DS-1 • DS-2 • RQ  
SI • RSI • CS  
ATS • SI • RSI • PSI

Drawings 1:1

Available compounds

SI • PSI

SBS 1001

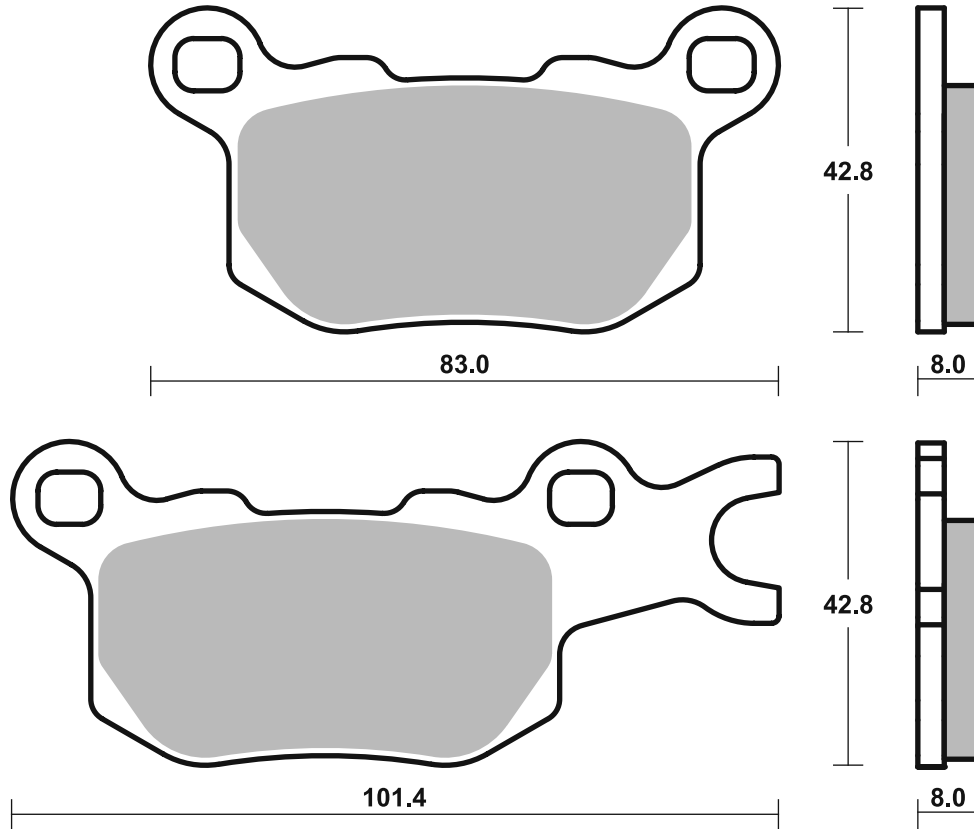

Available compounds

SI • PSI

SBS 1002

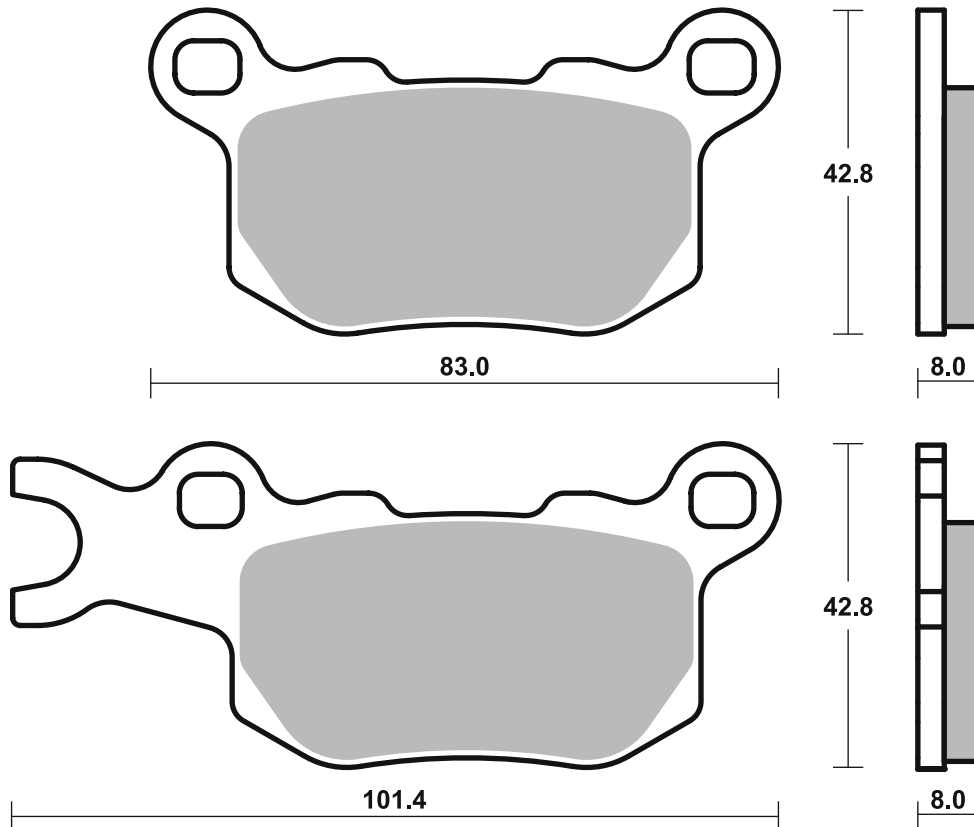

**SBS 1003** Recommended compound



<b>DUCATI</b>			
937	Multistrada V2	22 - 24	<b>LS</b>
937	Multistrada V2 S	22 - 24	<b>LS</b>
950	Multistrada	17 - 21	<b>LS</b>
950	Multistrada S	19 - 21	<b>LS</b>
1158	Multistrada V4	21 - 24	<b>LS</b>
1158	Multistrada V4		
	Rally	23 - 24	<b>LS</b>
1158	Multistrada V4S	21 - 24	<b>LS</b>
1158	Multistrada V4S		
	Sport	21 - 24	<b>LS</b>
1200	Multistrada Enduro	16 - 18	<b>LS</b>
1200	Multistrada Enduro		
	Pro	18 - 18	<b>LS</b>
1260	Multistrada Enduro	19 - 21	<b>LS</b>

**SBS 1004** Recommended compound



<b>BMW</b>			
R	1300 GS	24 - 24	<b>HS</b>

STREET  
AMERICAN  
SCOOTER

HF • HS • LS  
H.HF • H.CT • H.HS • H.LS  
HF • CT • MS

RACING  
OFF ROAD  
ATV

RST • DC • DCC • DS-1 • DS-2 • RQ  
SI • RSI • CS  
ATS • SI • RSI • PSI

Drawings 1:1

Available compounds

LS

SBS 1003

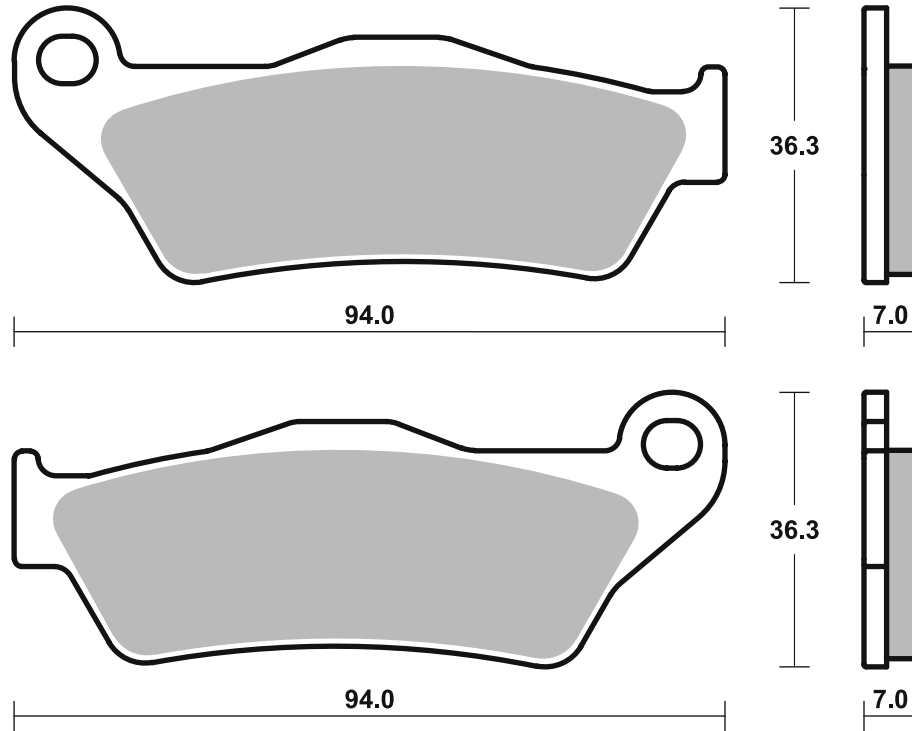

Available compounds

HS

SBS 1004

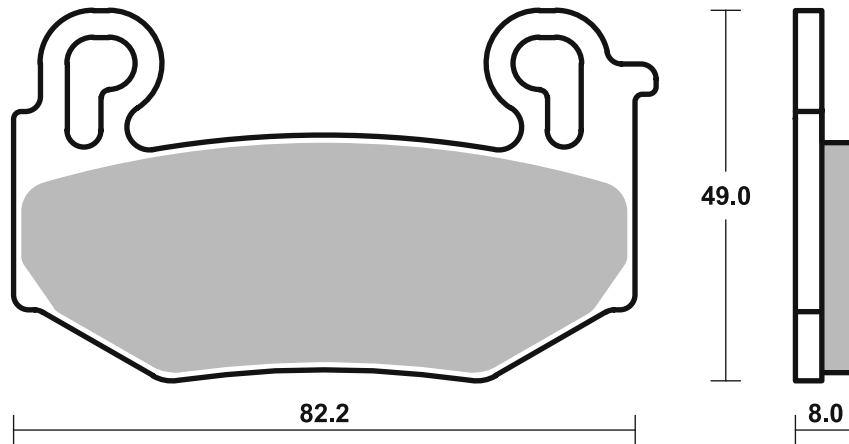





STREET  
AMERICAN  
SCOOTER

HF • HS • LS  
H.HF • H.CT • H.HS • H.LS  
HF • CT • MS

RACING  
OFF ROAD  
ATV

RST • DC • DCC • DS-1 • DS-2 • RQ  
SI • RSI • CS  
ATS • SI • RSI • PSI

Drawings 1:1

Available compounds

LS

SBS 1005

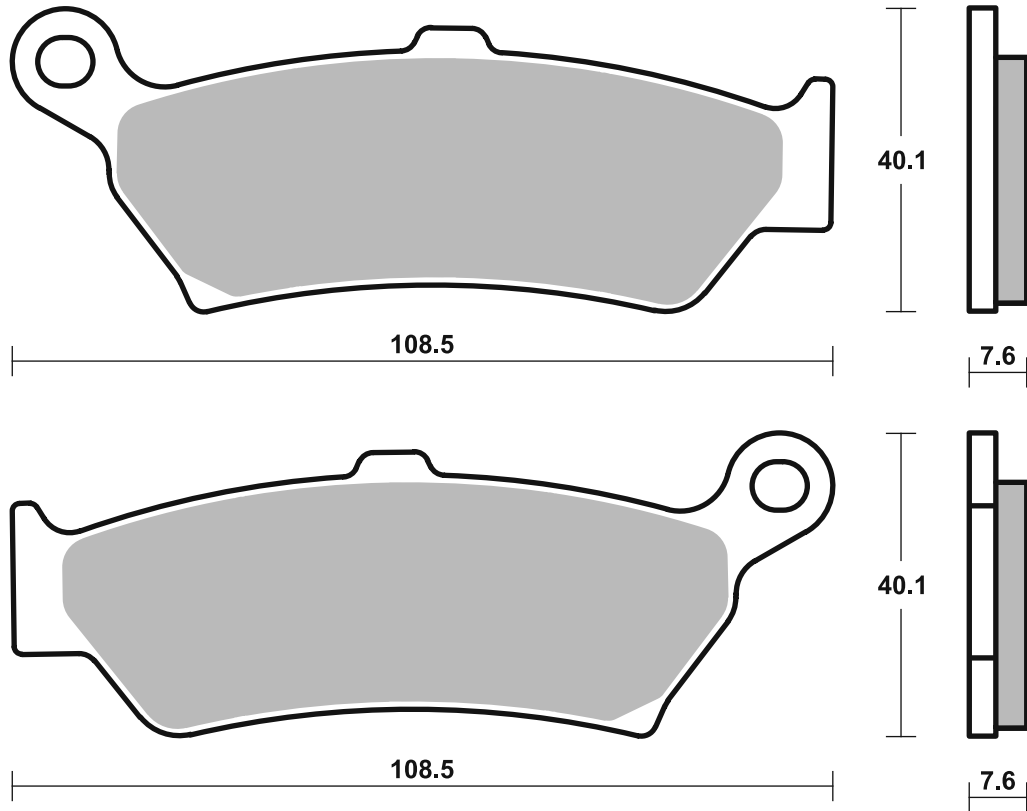

**ALMOST ANY BIKE**  
BRAKE PADS, CLUTCH KITS AND BRAKE DISCS

Find the right part with  
the **PRODUCT SELECTOR**  
at **SBSBRAKES.COM**

**sbs**<sup>®</sup>

GO AHEAD

HI-TECH BRAKE SOLUTIONS  
MADE IN EUROPE



Find the right brake pads, discs or clutches for your bike

Select the fields in any order

Brand\*  CC\*  Model\*  Year\*

SHOW MATCHES >

NEW SEARCH



@sbsbrakes | sbsbrakes.com | #GoAhead

# CROSSLIST

**BRAKE PADS**

**SAME SHAPE / DIFFERENT THICKNESS**

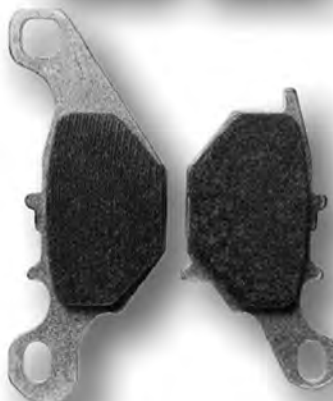
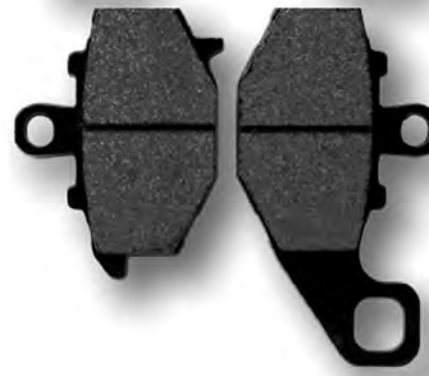
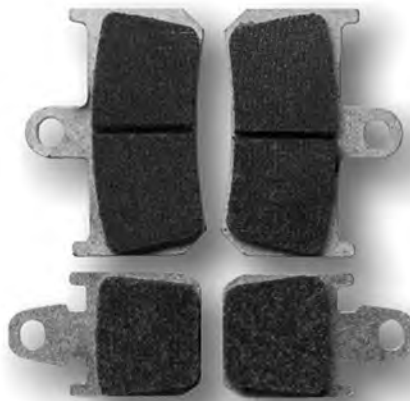
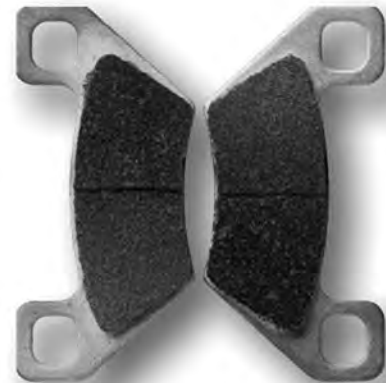
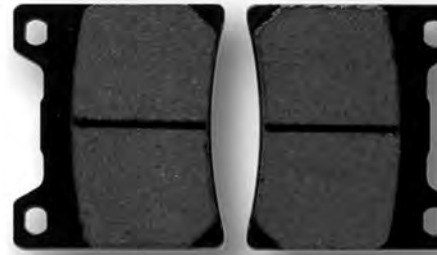
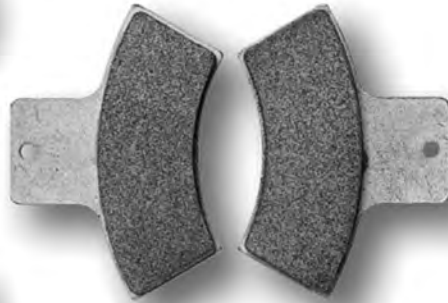

SBS Ref.	Total th.	SBS Ref.	Total th.	SBS Ref.	Total th.	SBS Ref.	Total th.	SBS Ref.	Total th.
103	7.0	200	7.5						
104	7.3	125	9.3						
115	8.0	209	5.3						
116	7.5	121	9.0	144	9.5				
119	9.2	134	8.0						
121	9.0	144	9.5	116	7.5				
123	6.3	143	7.0						
125	9.3	104	7.3						
127	9.0	160	11.0						
131	5.5	138	7.0						
134	8.0	119	9.2						
138	7.0	131	5.5						
142	6.9	202	6.2						
143	7.0	123	6.3						
144	9.5	116	7.5	121	9.0				
147	9.4	156	8.3						
156	8.3	147	9.4						
160	11.0	127	9.0						
163	9.2	197	8.0						
181	10.4	183	8.1	184	8.9				
183	8.1	184	8.9	181	10.4				
184	8.9	181	10.4	183	8.1				
197	8.0	163	9.2						
200	7.5	103	7.0						
202	6.2	142	6.9						
209	5.3	115	8.0						
216	7.0	222	9.0						
222	9.0	216	7.0						
223	9.0	236	7.0						
236	7.0	223	9.0						
508	12.0	517	9.5						
517	9.5	508	12.0						
519	7.0	583	5.5						
523	10.4	698	7.0						
526	11.0	556	9.0						
539	8.0	540	9.5						
540	9.5	539	8.0						
542	11.0	572	9.0						
551	7.0	814	7.5						
552	8.0	571	9.5						
556	9.0	526	11.0						
558	7.3	709	9.3						
571	9.5	552	8.0						
572	9.0	542	11.0						
581	7.1	582	9.5						
582	9.5	581	7.1						
583	5.5	519	7.0						
584	6.5	592	7.5						
590	10.5	613	8.8						
592	7.5	584	6.5						
599	8.0	661	9.0						
600	8.4	647	10.5	650	9.9				
604	9.5	690	9.0						
611	8.0	713	9.2						
613	8.8	590	10.5						
614	10.7	881	9.0						
624	8.5	714	7.0						
627	8.1	700	9.6	654	10.4	630	9.6		
630	9.6	627	8.1	700	9.6	654	10.4		
631	8.1	789	13.0						
632	8.7	648	9.5						
638	8.0	688	9.2						
647	10.5	600	8.4	650	9.9				
648	9.5	632	8.7						
650	9.9	600	8.4	647	10.5				
654	10.4	630	9.6	627	8.1	700	9.6		
661	9.0	599	8.0						
662	11.0	678	8.0						
670	8.0	879	5.3						
671	7.6	742	8.6/10.1	924	9.0	1003	7.0		
676	8.2	729	10.0	779	12.0				
678	8.0	662	11.0						

SBS Ref.	Total th.	SBS Ref.	Total th.	SBS Ref.	Total th.	SBS Ref.	Total th.	SBS Ref.	Total th.
688	9.2	638	8.0						
690	9.0	604	9.5						
695	8.3	711	10.2						
698	7.0	523	10.4						
700	9.6	654	10.4	630	9.6	627	8.1		
704	8.3	886	10.9	920	9.8				
706	8.6	727	7.6						
709	9.3	558	7.3						
711	10.2	695	8.3						
713	9.2	611	8.0						
714	7.0	624	8.5						
715	8.0	765	9.0	984	8.6				
720	9.0	751	7.0						
721	7.6	722	9.4	735	8.3	736	8.3	880	10.4
722	9.4	735	8.3	736	8.3	880	10.4	721	7.6
727	7.6	706	8.6						
729	10.0	676	8.2	779	12.0				
734	7.2	860	9.2	894	7.9				
735	8.3	736	8.3	722	9.4	880	10.4	721	7.6
736	8.3	722	9.4	735	8.3	880	10.4	721	7.6
742	8.6/10.1	1003	7.0	924	9.0	671	7.6		
743	7.7	778	9.0						
751	7.0	720	9.0						
754	9.5	835	8.3						
765	9.0	984	8.6	715	8.0				
767	9.5	836	8.3						
778	9.0	743	7.7						
779	12.0	676	8.2	729	10.0				
789	13.0	631	8.1						
805	10.0	887	9.0						
814	7.5	551	7.0						
835	8.3	754	9.5						
836	8.3	767	9.5						
860	9.2	734	7.2	894	7.9				
879	5.3	670	8.0						
880	10.4	736	8.3	722	9.4	735	8.3	721	7.6
881	9.0	614	10.7						
886	10.9	704	8.3	920	9.8				
887	9.0	805	10.0						
894	7.9	734	7.2	860	9.2				
920	9.8	704	8.3	886	10.9				
924	9.0	671	7.6	1003	7.0	742	8.6/10.1		
984	8.6	765	9.0	715	8.0				
1003	7.0	924	9.0	742	8.6/10.1	671	7.6		

# NEW! Get the brake feel you want!

# sbs<sup>®</sup>

GO AHEAD

Find the right brake pad compound for you and  
your bike with the new Compound Selector at  
[sbsbrakes.com](http://sbsbrakes.com)

Find the right compound for you and  
your bike

Click Start Now, answer 2-3 questions and get the answer right away

START NOW



@sbsbrakes | [sbsbrakes.com](http://sbsbrakes.com)

HI-TECH BRAKE SOLUTIONS  
MADE IN EUROPE



# BRAKE SHOES

## DRAWINGS, FITMENTS





HONDA			
CRF	50 F	04 - 24	• •
NA	50 Express	79 - 81	•
NB	50 ME, Aero	83 - 87	•
NC	50 Express	77 - 80	• •
NC	50 Express	81 - 83	•
ND	50 C, ML Melody	82 - 85	•
NE	50 MF, MG, TH Vision	85 - 87	•
NN	50 MD Gyro	84 - 84	• •
NP	50 Melody D Mini	83 - 87	•
NQ	50 D, Spree	84 - 87	• •
NT	50 F, G, H Melody Mini	85 - 87	• •
NX	50 A, B, MC Caren	82 - 82	•
OR	50	93 - 93	•
PA	50	78 - 81	•
PA	50	82 - 83	• •
PC	50 K1	79 - 79	• •
QR	50	93 - 03	•
QR	50 ED, EF	82 - 92	•



HONDA			
SA	50 Elite LX, SR	88 - 93	•
SB	50	88 - 89	• •
TG	50 M Gyro S	85 - 86	• •
XR	50 R	00 - 03	• •
Z	50 R, RD	80 - 99	• •
CT	70	91 - 94	• •
PEUGEOT			
ST	50	98 - 99	•
STL 2	50	90 - 94	•
SUZUKI			
DR-Z	50	19 - 24	• •
DR-Z	70	08 - 20	• •
YAMAHA			
TT-R	50	06 - 21	• •

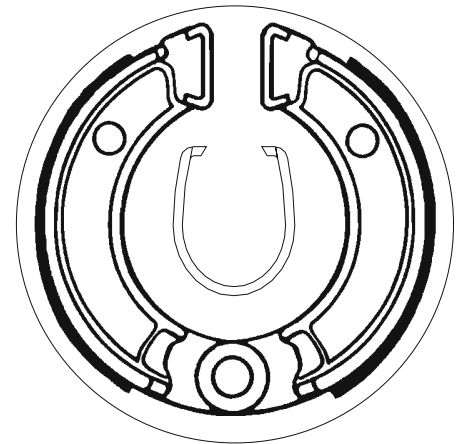

HERCULES			
	50 Limbo	95 - 95	•
HONDA			
GP	50 Dio	89 - 90	•
NA	50 Express	79 - 81	•
NB	50 ME, Aero	83 - 87	•
NC	50 Express	81 - 83	•
ND	50 C, ML Melody	82 - 85	•
NE	50 MF, MG, TH Vision	85 - 87	•
NH	50 Lead	83 - 83	•
NH	50 Lead	86 - 94	•
NH	50 Lead (Drum vers.)	94 - 94	•
NH	50 Lead SS,MR,MSE	84 - 85	•
NP	50 Melody D Mini	83 - 87	•
NS	50 F, Aero	88 - 91	•
NS-1	50	91 - 94	•
NU	50 MC Runaway, Express	82 - 83	•
NV	50 MSD Stream	84 - 86	• •
NX	50 A, B, MC Caren	82 - 82	•
OR	50	93 - 93	•
PX	50	82 - 83	•
QR	50 ED, EF	82 - 92	•
SA	50 Elite LX, SR	88 - 93	•
Lead	80 SS	85 - 85	•
NH	80 Lead Scooter	85 - 95	•
NH	80 MD Lead, Aero	83 - 84	•
R	80 Lead	88 - 95	•
PEUGEOT			
	50 Metropolis	85 - 90	•
	50 Rapido	85 - 93	•
	50 Zenith	94 - 01	•
SC	50	85 - 90	•
ST	50	98 - 99	•
STL 2	50	90 - 94	•
SC	75	74 - 77	•
SX	75	74 - 77	•
	80 Metropolis	80 - 80	•
SX	80	85 - 94	•
SX	80 Pro	85 - 94	•
PGO			
	50 Star	91 - 93	•



PGO			
	80 Star	91 - 95	•

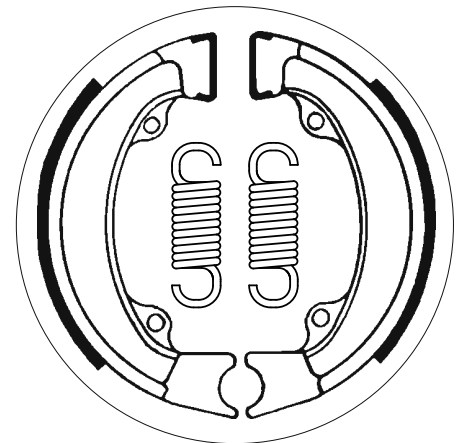





<b>APRILIA</b>			
50 Amico	90 - 91	•	•
50 Amico, GL, GLE	93 - 98		•
50 Gulliver	96 - 00		•
50 Rally	95 - 01	•	•
50 Scarabeo Street	00 - 06		•
50 Scarabeo, 2nd series	94 - 99		•
50 Sonic, GP	99 - 09		•
AC 50 Rally	95 - 02		•
LX 50 Amico, Sport	92 - 97		•
SR 50 Europa	93 - 94		•
SR 50 Replica	94 - 96		•
SR 50 Replica (Liquid Cooled)	96 - 96		•
SR 50 Urban Kid	93 - 07		•
SR 50 Viper	93 - 94		•
SR 50 WWW, Netscaper	97 - 99		•
<b>BENELLI</b>			
50 Chrono	92 - 94		•
50 Nemo, Quadra	94 - 94		•
50 Pepe	99 - 11		•
491 50 GT, Sport	98 - 99		•
491 50 Naked	99 - 02		•
491 50 ST	01 - 02		•
<b>BETA</b>			
50 Chrono 13	94 - 99		•
50 Quadra	95 - 96		•
50 Tempo	92 - 96		•
<b>BS VILLA</b>			
AX 50	93 - 93		•
GZ 50	93 - 93		•
<b>CAGIVA</b>			
50 City	92 - 97		•
<b>E-TON</b>			
RXL 150 Viper	07 - 07	•	
<b>HERCULES</b>			
50 Gipsy, Splinter, Reggae	95 - 95		•
50 Limbo	95 - 95		•
SR 50 Samba	93 - 93	•	•
SR 80 Samba	93 - 93	•	•
<b>HONDA</b>			
50 Sky Classic	00 - 03		•
50 Sky Vetro	00 - 02		•
C 50 all models	75 - 93	•	•
CF 50 Chaly	79 - 79	•	•
NH 50 Lead	83 - 83	•	•
NH 50 Lead (Drum vers.)	94 - 94	•	•
PK 50 Walaroo DX-STD	90 - 01		•
R 50 Monkey	88 - 88		•
SFX 50 Sport	96 - 04		•
SGX 50 Sky DX	97 - 03		•
SH 50 City Express	84 - 96		•
SH 50 Scoopy	88 - 04	•	•
SH 50 T	97 - 97		•
SJ 50 Bali	93 - 98		•
SS 50 K2	75 - 77	•	•
SS 50 ZB2	75 - 80		•
ST 50 Dax	78 - 93	•	•
C 70 all models	75 - 83	•	•
CF 70 K2, C	78 - 78	•	•
ST 70 Dax	78 - 93	•	•
75 Yupy	90 - 95		•
NF 75	79 - 79	•	•

<b>HONDA</b>			
SA 75 Vision	89 - 92	•	
SH 75 Scoopy	88 - 95	•	
XR 75 K5	79 - 79	•	
CH 80 Elite	85 - 88	•	
NH 80 Aero	85 - 85	•	
NH 80 MD Lead, Aero	83 - 84	•	
SH 80 Scoopy	88 - 93	•	
C 90 all models	75 - 92	•	•
EZ 90 Cub	90 - 95	•	•
H 100 A, SD, SG, SJ	82 - 92	•	•
SJ 100 Bali	97 - 03		•
ANF 125 i Innova	07 - 11		•
ANF 125 Innova	03 - 06		•
ATC 125 ME, MF, MG, MH	84 - 87	•	
CB 125	72 - 74	•	•
CB 125 S	84 - 85		•
CG 125 A, B, C	77 - 84	•	•
CG 125 E, F, J	85 - 91		•
CH 125 D, E, Spacy, Elite	83 - 84	•	•
MTX 125 Camel, Italy	88 - 98		•
NH 125 Lead Scooter	86 - 87		•
NH 125 Lead, Aero	83 - 84	•	•
NS 125 Italy	85 - 88		•
NSR 125 F	88 - 89		•
RTV 125 NRS, Italy	87 - 87		•
SL 125 K1A	76 - 76	•	•
TRX 125	85 - 88	•	•
XL 125 K3	79 - 79	•	
CH 150 D Elite	85 - 87	•	•
ATC 185 A, S, SB	80 - 83	•	
ATC 200	81 - 83	•	
XL 200 R, P.D., Italy	85 - 85		•
<b>KTM</b>			
GO 50	94 - 97		•
<b>KYMCO</b>			
50 Agility	05 - 08		•
50 Agility (4T) R10	06 - 14		•
50 Agility (4T) R12	06 - 15		•
50 Agility Basic	07 - 07	•	•
50 Calypso	97 - 99		•
50 Cobra Cross	99 - 06		•
50 Cobra Exclusive	01 - 04		•
50 Cobra Racer	99 - 04		•
50 Dink, Dink Sport, B&W	99 - 02		•
50 Easy	01 - 01		•
50 Filly	99 - 03	•	•
50 Filly LX	01 - 01		•
50 Heroism	95 - 99		•
50 Manboy	95 - 00		•
50 MXer	03 - 07	•	
50 MXU	05 - 10	•	
50 Refined	94 - 98	•	•
50 Scout	95 - 00		•
50 Sento	08 - 10		•
50 Spacer	99 - 06		•
50 Topboy on/off road	96 - 05		•
50 Topboy Racer/Cross	01 - 05		•
50 Yager	01 - 07		•
50 Yup	01 - 01		•
CX 50	94 - 97	•	
DJ 50	99 - 02	•	
DJ 50 Refined	99 - 02	•	
DJW 50	94 - 97	•	
DJX 50	91 - 92	•	
DJY 50	93 - 06	•	
K12 50	95 - 00		•
KB 50	95 - 00		•



KYMCO			
80 Filly	99 - 02	•	•
90 Manboy	96 - 01	•	•
100 Cobra Racer	99 - 03	•	•
100 Topboy on/off road	99 - 00	•	•
KB			
100	99 - 00	•	•
125 Agility	06 - 11	•	•
125 Calypso	99 - 99	•	•
125 Heroism	95 - 97	•	•
125 MXer	03 - 07	•	•
B			
125 Freeway	93 - 95	•	•
D2			
125 Freeway	95 - 92	•	•
150 Freeway	95 - 00	•	•
150 MXer	03 - 13	•	•
150 MXU	05 - 17	•	•

MALAGUTI			
50 Centro	93 - 96	•	•
50 Ciak	00 - 09	•	•
50 Yesterday	97 - 02	•	•
F-10			
50	92 - 93	•	•
50 Jet-Line	94 - 98	•	•
F-12			
50 Phantom	94 - 98	•	•
50 Phantom A.C.	99 - 03	•	•
50 Phantom L.C.	94 - 98	•	•
F-15			
50 Fire Fox	96 - 08	•	•
50 Fire Fox L.C.	96 - 08	•	•
SL			
50 Centro	96 - 00	•	•

PEUGEOT			
e-Vivacity	11 - 15	•	•
50 Buxy (A.J.P. cal.)	94 - 97	•	•
50 Buxy (Brembo cal.)	94 - 97	•	•
50 Buxy (Hengtong cal.)	94 - 97	•	•
50 Elyseo (A.J.P. cal.)	99 - 01	•	•
50 Looxor	02 - 05	•	•
50 Ludix	04 - 08	•	•
50 Ludix (Drum front)	04 - 05	•	•
50 Metropolis	85 - 90	•	•
50 Speedake (A.J.P. cal.)	94 - 01	•	•
50 Speedake (Brembo cal.)	94 - 01	•	•
50 Speedake (Hengtong cal.)	94 - 01	•	•
50 Speedfight 3 (AC)	10 - 16	•	•
50 Speedfight LC, (A.J.P. cal.)	96 - 15	•	•
50 Speedfight LC, (Brembo cal.)	96 - 15	•	•
50 Speedfight LC, (Hengtong cal.)	96 - 15	•	•
50 Squab (A.J.P. cal.)	94 - 04	•	•
50 Squab (Hengtong cal.)	94 - 04	•	•
50 Trekker Road	99 - 00	•	•
50 Tweet	10 - 13	•	•
50 V-Clic	08 - 13	•	•
50 Zenith	94 - 01	•	•
50 Zenith Luxe	94 - 00	•	•
SC			
50	85 - 90	•	•
SV			
50 APS	91 - 91	•	•
50 Geo	91 - 91	•	•
50 Geo	92 - 99	•	•
50 J,Junior	93 - 97	•	•
50 L	93 - 93	•	•
50 Roland Garros	93 - 93	•	•
50 Sport	93 - 93	•	•
SX			
50	75 - 80	•	•
75	74 - 77	•	•
75	74 - 77	•	•
80 Metropolis	80 - 80	•	•



PEUGEOT			
SC 80	76 - 79	•	•
SV 80 Geo	91 - 98	•	•
SX 80	85 - 94	•	•
SX 80 Pro	85 - 94	•	•
100 Elyseo (A.J.P. cal.)	99 - 01	•	•
125 Ludix	04 - 05	•	•
SV 125 C Executive	96 - 98	•	•
SV 125 Executive	94 - 95	•	•
SV 125 Geo	91 - 98	•	•

PGO			
50 Star	91 - 93	•	•
80 Star	91 - 95	•	•

SYM			
50 Fiddle	09 - 14	•	•
50 Jet, Alpha	95 - 97	•	•
50 Jungle	96 - 02	•	•
50 Mask	00 - 05	•	•
50 Mask LC	00 - 05	•	•
50 Red Devil	97 - 09	•	•
50 Super Fancy	95 - 97	•	•
RS			
50	05 - 09	•	•
100 Super Fancy	95 - 00	•	•
125 Attila	95 - 02	•	•
150 Super Duke	96 - 01	•	•

YAMAHA			
50 Axis Pro Foot	92 - 99	•	•
XC 150 Fly One	92 - 99	•	•



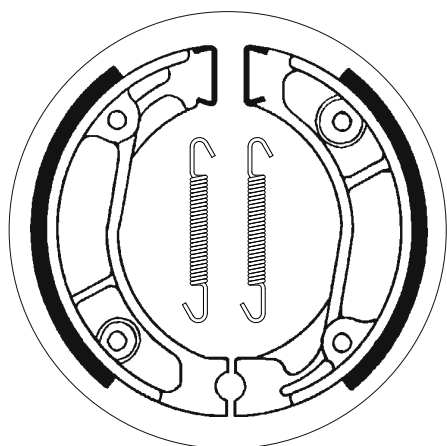

HONDA			
CB	50 all models	80 - 81	•
CB	50 all models	81 - 81	•
CB	50 J, K1	75 - 79	•
MB	50 S	80 - 82	•
MBX	50	80 - 82	•
MBX	50 S	83 - 85	•
MRX	50	88 - 92	•
MT	50 S	80 - 93	•
MTX	50 SC-SD	83 - 84	•
NSR	50	89 - 90	•
XL	50	77 - 82	•
NSR	75 FII	88 - 00	•
XR	75 K4	75 - 79	•
XR	75 K5	79 - 79	•
CR	80 R2	85 - 85	•
CR	80 RA, RB	80 - 81	•
CR	80 RC	82 - 82	•
MBX	80	83 - 87	•
MBX	80 DX	82 - 86	•
MBX	80 FWD	83 - 86	•
MBX	80 SW, SWD	83 - 83	•
MCX	80	82 - 85	•
MTX	80 R	87 - 87	•
MTX	80 RF	83 - 84	•
XR	80	79 - 84	•
C	90	93 - 02	•
NH	90 Yupy	90 - 94	•
CB	100 N	79 - 80	•
XL	100 all models	78 - 85	•
XR	100	81 - 84	•
CB	125 J	79 - 79	•
CB	125 S	76 - 78	•
CB	125 S	79 - 82	•
CBX	125 Custom	88 - 88	•
CR	125 M2, M3, M4	76 - 78	•
CT	125 C	85 - 85	•
MT	125 R	77 - 78	•
MTX	125 R	84 - 95	•
MTX	125 R, Italy	86 - 86	•
MTX	125 RWD	83 - 84	•
NX	125 , Transcity	90 - 98	•
R	125 Lead	88 - 88	•
SL	125 K1D, E, F, G, K2A	76 - 80	•
TL	125	76 - 76	•

HONDA			
XL	125 K2	78 - 78	•
XL	125 K3	79 - 79	•
XL	125 R	86 - 86	•
XL	125 R, P.D., Italy	85 - 85	•
XL	125 R, P.D., Italy, EX	87 - 87	•
XL	125 S	79 - 84	•
XLR	125 R	98 - 01	•
XR	125 L	03 - 07	•
CRF	150 F	03 - 06	•
CBX	185 Custom	88 - 88	•
XL	185 S	79 - 83	•
CTX	200	04 - 06	•
MTX	200 R	85 - 86	•
MTX	200 RWD	83 - 84	•
TL	200 J, Y	76 - 78	•
TLR	200 Fatcat	86 - 87	•
TLR	200 G, H	86 - 87	•
TR	200	86 - 87	•
XL	200 R	83 - 84	•
XR	200	80 - 84	•
XR	200 R	84 - 02	•
XR	200 R, Pro Link	81 - 83	•
CRF	230	04 - 09	•
RTL	250 SG	86 - 86	•
TL	250	75 - 76	•
TL	250 K1	79 - 79	•
TLM	250 RJ	89 - 89	•
TLR	250 R	85 - 87	•
XL	250 R	84 - 87	•
XLR	250 R	88 - 89	•
XR	250 R	84 - 89	•
NX	350	88 - 99	•
XR	350 R	83 - 85	•
XR	500 R, Pro Link	83 - 84	•
XR	600 R	83 - 90	•

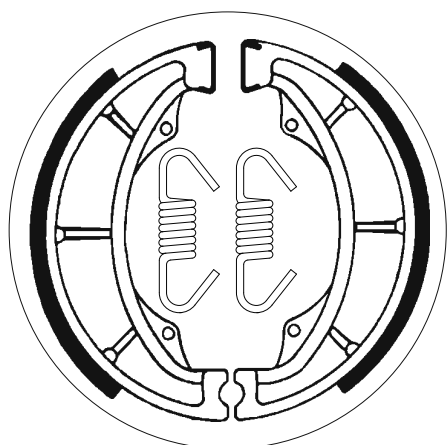

HONDA			
ATC	250 R	81 - 81	•

HYOSUNG			
GV	250	02 - 09	•

KAWASAKI			
KH	100	78 - 81	•
KH	100 EX	88 - 93	•
KE	125	86 - 91	•
KH	125	82 - 98	•
KZ	200	78 - 79	•
Z	200	77 - 81	•
Z	200	83 - 85	•
KZ	250	80 - 83	•

SUZUKI			
PV	50	82 - 97	•
RG	80	85 - 87	•

SUZUKI			
RG	80 Gamma	88 - 93	•
RM	80	83 - 85	•
TS	90	71 - 73	•
A	100 all models	74 - 80	•
ACC	100	70 - 72	•
ASS	100	69 - 71	•
GP	100	79 - 92	•
RM	100	76 - 78	•
TS	100	73 - 75	•
TS	100	75 - 81	•
TS	100 E	82 - 87	•
B	120	71 - 77	•
DR	125	82 - 84	•
DR	125	86 - 02	•
EN	125	05 - 09	•
GN	125	82 - 10	•
GP	125 all models	77 - 84	•
GP	125 C (Norway)	78 - 78	•



SUZUKI			
GS	125	82 - 84	• •
GS	125 E, Katana	90 - 94	•
GS	125 ESD	83 - 94	•
GS	125 ESZ	82 - 82	•
GT	125	75 - 82	•
GX	125 R	88 - 03	•
GZ	125 Marauder	00 - 11	•
RG	125	79 - 80	•
RG	125 Gamma	85 - 90	•
RM	125	75 - 78	• •
RM	125	79 - 83	•
SP	125	82 - 83	• •
SP	125	86 - 88	•
TS	125	72 - 72	•
TS	125	73 - 81	• •
TS	125	82 - 82	•
TS	125	84 - 84	•
TS	125	84 - 84	• •
X4	125 , X3E	78 - 80	•
GT	185	75 - 77	•
TS	185	74 - 81	•
DR	200	86 - 88	•
DR	200 S	15 - 17	•
DR	200 SE	96 - 13	•
DR	200 T	96 - 96	•
GT	200 X5 (Nien)	79 - 82	•
SB	200	79 - 81	•
SP	200	86 - 88	•
SX	200 R	85 - 89	•
XS	200	79 - 79	•
DR	250	82 - 83	•



SUZUKI			
DR	250	85 - 89	•
GN	250	86 - 97	•
GZ	250 Marauder	00 - 08	•
RM	250	76 - 78	•
SP	250	85 - 85	•
TU	250 X Super Classic	97 - 00	•
VL	250 Intruder	00 - 07	•
RL	325	80 - 82	•
RM	400	78 - 78	•
RM	465	81 - 82	•
DR	500	89 - 89	•
RM	500	83 - 87	•
DR	600 Djebel	86 - 88	•
DR	600 S Dakar	85 - 87	•
SP	600 F	85 - 87	•
<b>YAMAHA</b>			
	225 Serow	85 - 87	•

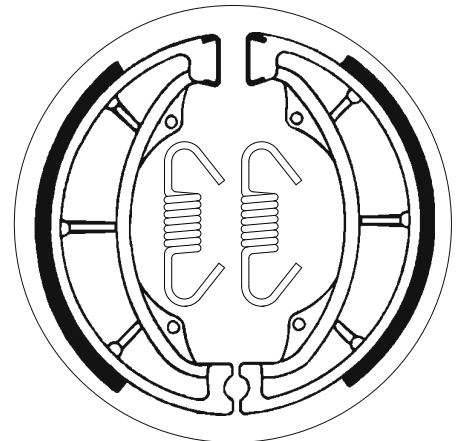

HYOSUNG			
	110 Midas Plus	98 - 04	•
FX	110 110	02 - 04	•
KR	110 Master	04 - 05	•
<b>KAWASAKI</b>			
AE	50	81 - 82	• •
AR	50	81 - 82	•
KMX	50	88 - 93	•
AE	80	81 - 86	• •
AR	80	81 - 82	•
KD	80	80 - 87	• •
KD	80	88 - 90	•
KMX	80	87 - 92	•
KC	100	80 - 83	• •
KE	100	79 - 97	• •
KH	100	76 - 77	• •
KH	100	78 - 81	•
KH	100 EX, G	81 - 82	•
KH	100 GH	83 - 87	•
KM	100	78 - 81	• •
KLF	110 Mojave	87 - 88	•
KLT	110	84 - 86	•
KLX	110	02 - 24	•
KLT	160	85 - 85	•
KLT	185	86 - 87	•
KLT	200	81 - 84	•
KLT	250	82 - 83	•
KLT	250 Police	84 - 84	•
KLT	250 Prairie	83 - 85	•



PUCH			
AP	50	71 - 80	• •
<b>SUZUKI</b>			
A	50	71 - 76	• •
AC	50 DX	81 - 86	•
AC	50 RG, ZR, Z1	79 - 84	•
AP	50	75 - 78	• •
AP	50	95 - 02	•
F	50	71 - 73	• •
FR	50	74 - 81	• •
GT	50	77 - 80	•
OR	50	79 - 79	• •
RB	50	87 - 87	•
RM	50	75 - 76	•
RM	50	78 - 80	• •
RV	50	72 - 82	• •
TS	50	80 - 83	•
TS	50 ERA	80 - 80	• •
TS	50 KN	79 - 79	• •
X-1	50	79 - 79	•
FR	70	74 - 76	• •
FR	80	76 - 83	• •
GT	80 L/C	81 - 81	•
RM	80	77 - 79	• •
RT	80	81 - 82	• •
RV	90	73 - 81	• •
TS	90	71 - 73	•
A	100 all models	74 - 80	•
ASS	100	69 - 71	•
GP	100	78 - 92	•
RM	100	76 - 81	•

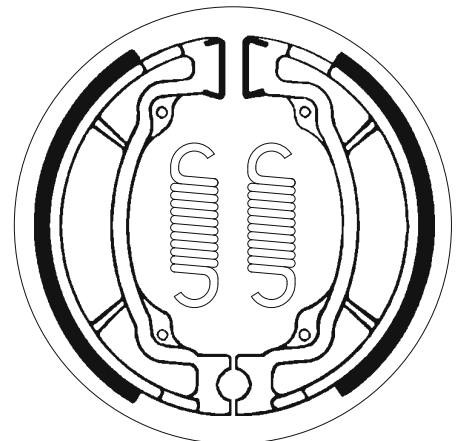

ø110 x 30

SBS 2015

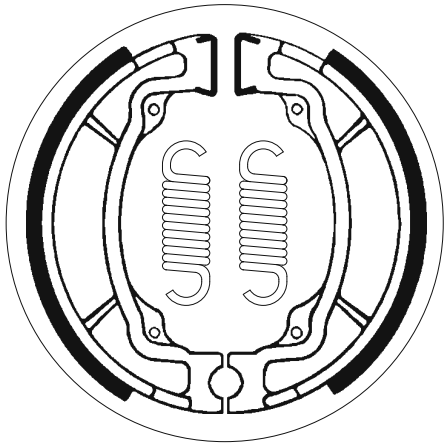

SUZUKI			
TS	100	73 - 75	•
	110 Smash	03 - 06	• •
DR-Z	110	02 - 06	•
FX	110 Shogun	98 - 02	• •
CS	125 D	83 - 85	• •
TS	125	72 - 72	•
RL	325	80 - 82	•

ø150 x 28

SBS 2016

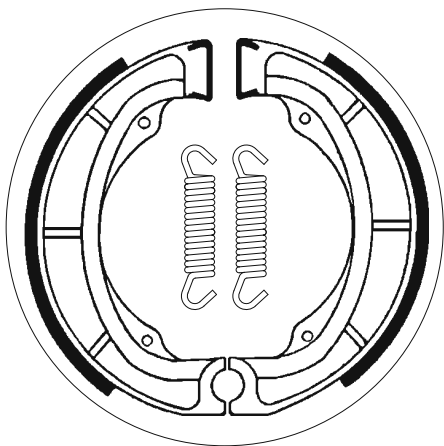

KAWASAKI			
KDX	250	80 - 82	•
KL	250	78 - 80	•
KX	250	75 - 81	•
KZ	250	80 - 83	•
KX	420	80 - 81	•
SUZUKI			
ALT	125	84 - 86	•
LT	125 E-H	84 - 87	•
LT	160	89 - 92	•
LT-F	160	91 - 04	•
ALT	185	85 - 87	•
LT	185	84 - 87	•
SB	200	79 - 81	•
LT	230	85 - 86	•
LT-F	230	86 - 87	•
RM	250	76 - 78	•
RM	250	79 - 79	•

SUZUKI			
TS	250	74 - 82	• •
TS	250 X	85 - 89	•
SP	370	77 - 79	• •
DR	400	79 - 81	• •
PE	400	79 - 81	• •
RM	400	78 - 78	•
RM	400	79 - 79	•
SP	400	80 - 82	• •
DR	500	83 - 88	• •

ø110 x 25

SBS 2017

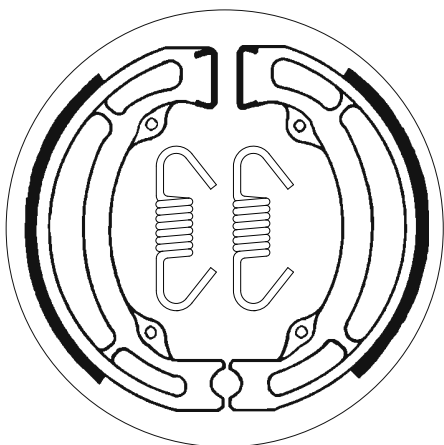

SUZUKI			
GSRX	50	87 - 87	•
LT-A	50 Quadmaster	01 - 05	•
LT-Z	50 Quadsport	06 - 20	•
OR	50	80 - 80	• •
OR	50 E	80 - 80	• •
RM	50	81 - 82	• •
TS	50	80 - 83	• •
TS	50 ERZ1	80 - 83	• •
ZR	50	81 - 87	•
DS	80	80 - 96	• •
JR	80	01 - 07	• •
RM	80	80 - 81	• •
RM	80	83 - 85	• •
TS	80	81 - 82	• •
LT-Z	90 Quadsport	07 - 20	• •
DR	100	83 - 90	• •
TS	100 E	82 - 87	• •
DR-Z	125 K	03 - 12	• •

SUZUKI			
DR-Z	125 L	03 - 24	•
TS	125	82 - 82	•

SBS 2018

ø160 x 30



SUZUKI			
GNX	250	82 - 84	•
GS	250	80 - 82	•
GSX	250	80 - 81	•
GSX	250	85 - 85	•
GT	250	78 - 81	•
SW1	250	92 - 95	•
GS	300	82 - 85	•
GN	400	80 - 80	•
GSX	400	80 - 83	•
GSX	400 E, S	85 - 86	•
GSX	400 EFX	82 - 82	•
LS	400 Savage	87 - 91	•
LT-A	400 Eiger 2WD/4WD	02 - 07	•
LT-F	400 Eiger 2WD/4WD	02 - 07	•
GS	425	79 - 80	•
GS	450	80 - 83	•
GS	450	85 - 85	•
GR	650 X	83 - 84	•



SUZUKI			
LS	650	05 - 05	•
LS	650 P	86 - 88	•
LS	650 P Savage	95 - 04	•

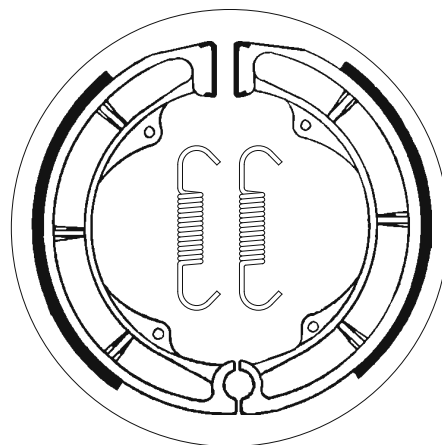

SBS 2019

ø140 x 28



HONDA			
ATC	80	76 - 78	•
ATC	90 K1, K2, K3	73 - 78	•
TRX	90	93 - 01	•
ATC	110 all models	79 - 85	•
ATC	125 ME, MF, MG, MH	84 - 87	•
TRX	125	85 - 88	•
CD	175 all models	71 - 78	•
ATC	185 A, S, SB	80 - 83	•
ATC	200	81 - 83	•
ATC	200 E Big Red	82 - 83	•
ATC	200 ES Big Red	84 - 84	•
ATC	200 M	84 - 85	•
ATC	200 S	84 - 86	•
TRX	200	84 - 84	•
TRX	200	90 - 91	•
TRX	200 D Type II	91 - 97	•
TRX	200 SX	86 - 88	•
ATC	250 ES, SX	85 - 87	•



HONDA			
FL	250 Odyssey	77 - 84	•

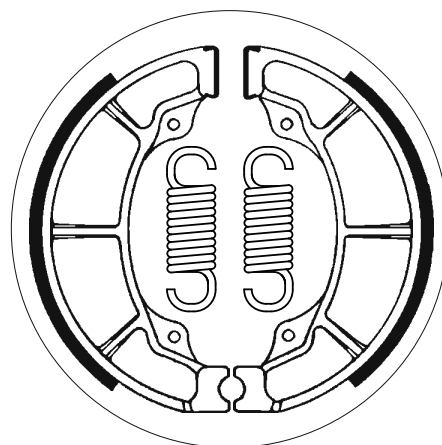

SBS 2020

ø90 x 20



HONDA			
CBX	125 F	84 - 88	•

SUZUKI			
ALT	50	83 - 84	•
CL	50 D, Suzi, Love	83 - 83	•
CS	50 Roadie	83 - 83	•
JR	50	89 - 07	•
LT	50	84 - 02	•

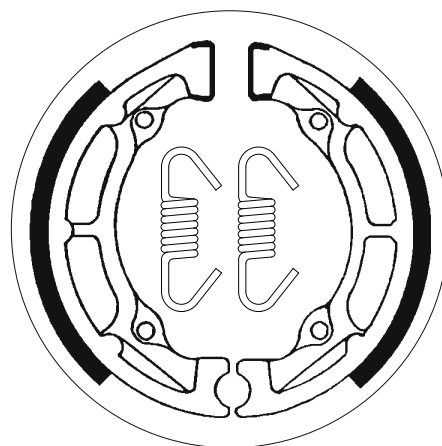

ø95 x 20

SBS 2021

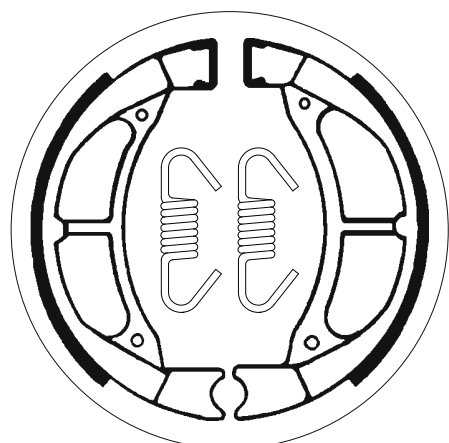

MBK			
50 Active	89 - 89	•	•
50 Hot Champ	91 - 97	•	
75 Active	90 - 90		•
80 Active	89 - 89	•	•

YAMAHA			
SG 50 Sting	84 - 91	•	•
SH 50 E, F Razz	93 - 95		•
SH 50 Mint	93 - 96		•
SH 50 T, EMT, U, MU, W, MW, A, MA, B, D, MD	87 - 93		•

YAMAHA			
50 Beluga	88 - 89	•	•
CA 50 Riva Saliient	83 - 86		•
CG 50 A, B Riva Jog	90 - 91		•
CY 50 F Jog	94 - 94	•	
JOG 50 (Spain)	88 - 88		•
JOG 50 CY	90 - 92	•	
JOG 50 E	88 - 90		•
JOG-Z 50	90 - 91		•
LC 50 M, Bop, G, H Champ	80 - 81	•	•
MS 50	85 - 86		•
RS 50 Champ	88 - 93		•
SA 50 M, ME Passola	80 - 84		•

YE 50 Zest (Japan)	92 - 95		•
CH 80 Beluga (CH 80)	90 - 90		•
YE 80 Zest (Japan)	93 - 95		•
JOG 90	90 - 91		•

ø100 x 20

SBS 2022

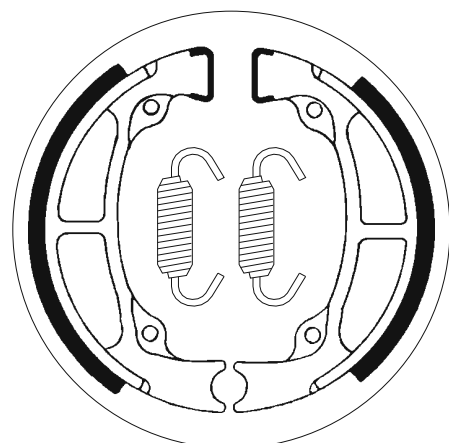

SUZUKI			
RM 80	82 - 85	•	

ø140 x 25

SBS 2023

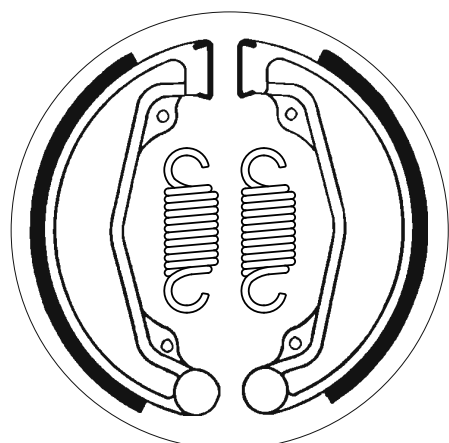

HONDA			
CD 125	82 - 82	•	
CM 125	82 - 85	•	
CD 185 T	78 - 82	•	
CM 185 T	78 - 79	•	
CD 200 T	79 - 79	•	
CM 200 TA, TB	80 - 82	•	
CB 250 Nighthawk	91 - 02	•	
CL 250 SC	81 - 81	•	
CM 250 C	82 - 83	•	
MT 250 K1	74 - 76	•	•
XL 250	78 - 79		•
XL 250 S	78 - 81	•	
XR 250	79 - 80	•	
XL 350	76 - 78		•
XL 500 SZ	80 - 80	•	



HONDA			
ATC	250 ES, SX	85 - 87	•
CB	250 G, T	74 - 76	•
CB	250 K3-K5	73 - 75	•
CJ	250 T	76 - 78	•
TRX	250	85 - 87	•
TRX	300	88 - 00	•
TRX	300 4WD	88 - 00	•
CB	350 F, F1	73 - 76	•
CB	350 K4	74 - 74	•
CB	360 G, T	73 - 76	•
CJ	360 T	76 - 78	•
CL	360	74 - 77	•
CB	400 F, F1, F2	75 - 79	•
CB	400 NZ	79 - 79	•

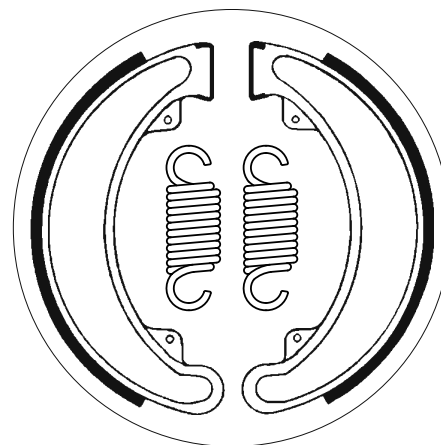

KAWASAKI			
KH	125	77 - 80	•
KX	125	83 - 85	•
KDX	200	83 - 85	•
KDX	200 C	86 - 88	•

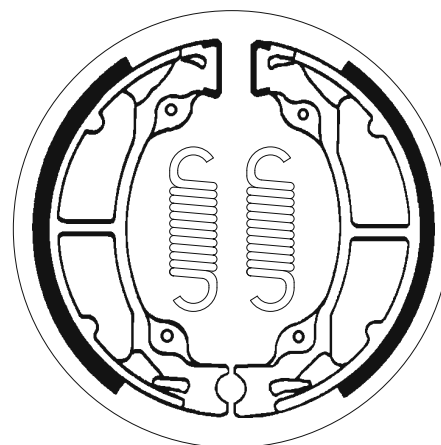

CAGIVA			
T4	350 R	87 - 99	•
T4	500 E	87 - 90	•

HONDA			
CA	125 Rebel	95 - 00	•
VT	125 C1 Shadow	99 - 08	•
VT	125 C2 Shadow	99 - 08	•
CBX	185 F	84 - 84	•
CBX	250 RSE	84 - 85	•
XL	250 S	81 - 81	•
XLR	400	83 - 83	•
XL	500 R	83 - 87	•
XL	500 RC	82 - 82	•
XL	500 SZ	80 - 80	•
XR	500 R	86 - 86	•
XR	500 R Pro Link	81 - 82	•
XR	500 SZ, SA	79 - 80	•
XL	600 LM, RM	85 - 87	•



HONDA			
XL	600 R	83 - 86	•
XL	600 V, Transalp	87 - 90	•
XLM	600 LM	87 - 91	•



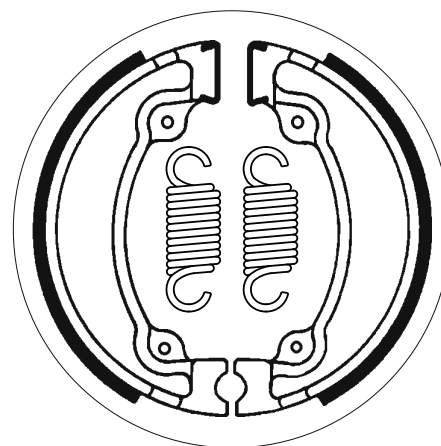

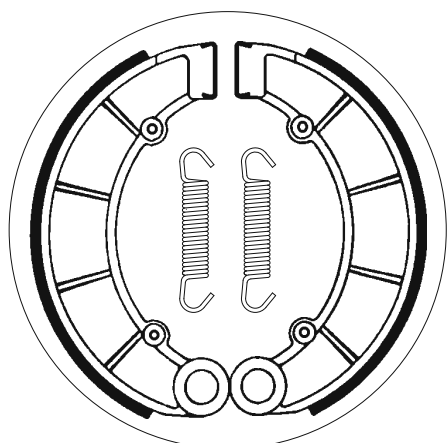

HONDA			
CB	650	79 - 81	•
CB	650 C	80 - 85	•
CB	650 SCC Nighthawk	82 - 82	•
CB	650 Z	78 - 81	•
CB	750 A	76 - 78	•
CB	750 C	80 - 84	•
CB	750 C, F, FII, K	85 - 86	•
CB	750 K Four	77 - 78	•
CB	750 K, L	79 - 80	•
CB	750 KO-K6 Four	70 - 76	•
CB	750 KZ	82 - 82	•
CB	750 PZ	81 - 84	•
CB	750 SC	82 - 83	•

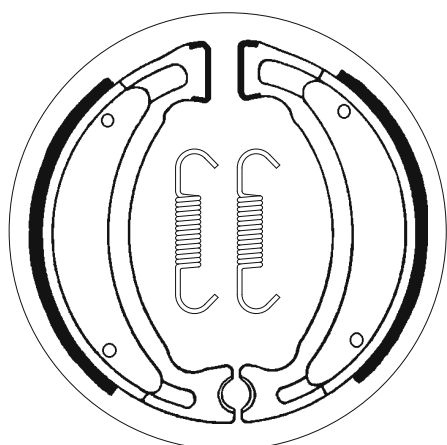

ADLY			
	25 Silver Fox	00 - 05	•
	50 Fox	00 - 09	•
	50 Jet	96 - 99	•
	50 Pista, Pista Twin		
	Light	96 - 99	•
	50 Silver Fox	00 - 09	•
	100 Jet	96 - 99	•
	100 Silver Fox	06 - 06	•
BARIGO			
	Scooter electric	97 - 97	•
BENELLI			
	50 Naked	02 - 02	•
LX	100 Pepe	02 - 06	•
CPI			
	50 Baby	02 - 02	•
	50 Hussar	01 - 06	•
	50 Mars	01 - 02	•
	50 Oliver	03 - 12	•
	50 Oliver City	03 - 12	•
	50 Oliver Sport	03 - 12	•
	50 Popcorn	01 - 02	•
DERBI			
DXR	200 Quad (Front drum)	04 - 05	•
DXR	250 Quad (Front drum)	04 - 05	•
EASY RIDER			
	50 Easy Rider	99 - 99	•
FANTIC			
	50 Pony	93 - 96	• •
	50 Pony SR	93 - 95	•
	50 Queenie	95 - 96	•
GENERIC			
	50 Ideo	06 - 13	•
	50 XOR	06 - 13	•
KEEWAY			
	50 Flash	07 - 12	•
	50 Flash Electric	10 - 12	•
KEEWAY			
	50 Hurricane	06 - 16	•
	50 Matrix	06 - 15	•
F-NKD	50	10 - 11	•
RY8	50	07 - 09	•
KOTIR			
RS	50	90 - 90	• •
KREIDLER			
	50 Florett	99 - 06	•
KTM			
X-1	50	98 - 91	•
LEM			
	50 Flash	94 - 98	•
	50 Ghibli	90 - 95	• •
MAICO			
	50 Classic	99 - 99	• •
	50 Cruiser	99 - 99	•
	50 Thunderbike I	99 - 99	•
	50 Thunderbike II	99 - 99	•
	50 Trafficjammer	99 - 99	• •
C-1	50 Hard Enduro	99 - 99	•
R-1	50 Superbike	99 - 99	•
X-1	50 SuperCross	99 - 99	•
MBK			
	50 Equalis	96 - 98	•
	50 Fizz	93 - 00	•
	50 Forte	94 - 98	•
	50 Sorriso	92 - 95	• •
	50 Target	92 - 95	•
	80 Evolis	94 - 98	•
	125 Flame R/F	95 - 03	•
POLARIS			
	250 Cyclone	87 - 87	•
	350 Trail Boss 2x4	85 - 87	•
SMC			
	50 Easy Rider	97 - 97	•



SULA		
50	City Bird	99 - 99 •
50	Thunder Bird	99 - 99 •
100	Thunder Bird	99 - 99 •
125	Thunder Bird	99 - 99 •
YAMAHA		
CR	50 Target	91 - 95 •
CX	50	88 - 93 • •
CY	50 F Jog	94 - 94 •
DT	50 LCD	98 - 01 •
DT	50 R	98 - 03 •
YE	50 Zest (Italy)	92 - 95 •
YFM	50 Raptor	04 - 11 •
YSR	50	87 - 91 •
	80 Beluga	81 - 89 • •
CV	80 Riva	83 - 87 • •
CW	80 Beluga	81 - 83 • •
PW	80	91 - 08 •
TY	80	83 - 84 •
YFM	80	92 - 94 •
YFM	80 Badger	95 - 07 •
YFM	80 Grizzly	05 - 08 •
YFM	80 Raptor	02 - 08 •
YSR	80	86 - 92 •
CR	90 Target	91 - 94 •
TT-R	90	00 - 10 •
YFM	90 RY Raptor	09 - 15 •
RS	100 DX	77 - 82 •
RT	100 A-H	90 - 96 • •
YB	100	82 - 86 •
YB	100	87 - 92 • •
YFM	100 Champ	89 - 91 •
YZ	100	82 - 83 •
TT-R	110	08 - 24 •
SR	125 SE	82 - 82 •
TT-R	125	00 - 13 • •
TT-R	125 LW	00 - 24 •
TW	125	99 - 07 •
XT	125	82 - 86 •
YFA	125 1 D, E Breeze	92 - 93 •
YFA	125 1 F Breeze	94 - 94 •
YFA	125 1 G-M Breeze	95 - 07 •
YFA	125 1 W, A, B Breeze	89 - 91 •
YFM	125 Grizzly	04 - 13 •



YAMAHA		
XC	150 Fly One R	98 - 02 •
YT	175 Tri Moto	82 - 83 •
SR	185 Exiter, H, J	81 - 82 •
BW	200	85 - 88 • •
TT	200	86 - 89 •
TW	200	87 - 15 •
XT	200	85 - 95 •
YFM	200 DXS-DXW Moto 4	86 - 87 •
YFM	200 N Moto 4	85 - 89 •
YFS	200 U-P Blaster	88 - 02 •
YTM	200 EK, EL Tri Moto	83 - 84 •
YTM	200 ERN Tri Moto	85 - 85 •
YTM	200 K-N Tri Moto	83 - 85 •
TT	225 S,T	86 - 00 •
TTR	225	01 - 04 •
XT	225	92 - 01 •
XT	225 Serow	86 - 86 •
YFM	225 Moto 4	86 - 88 •
YTM	225 DRN, DRS Tri Moto	85 - 86 •
YTM	225 DXK, DXN Tri Moto	83 - 85 •
YFB	250 Timberwolf	92 - 94 •
YFM	350 ERT, ERU	87 - 88 •

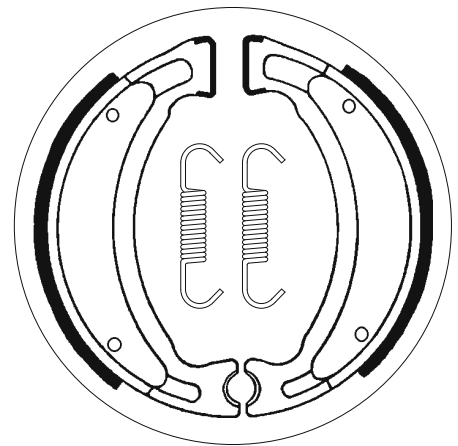

HONDA		
NX	250	88 - 90 •
XL	250 Degree	91 - 91 •
XL	250 R	82 - 83 •
XL	250 S	78 - 80 •
XR	250	79 - 80 •
XR	250 R	81 - 83 •
XL	350 R	84 - 87 •

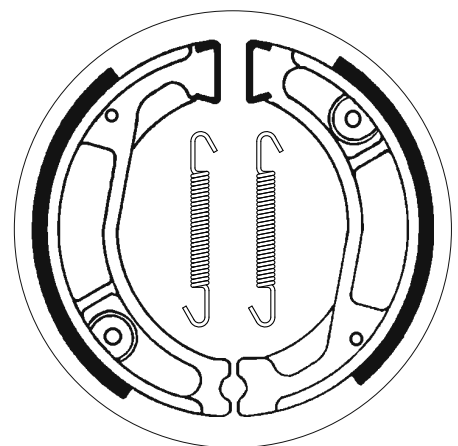

ø130 x 25

SBS 2030

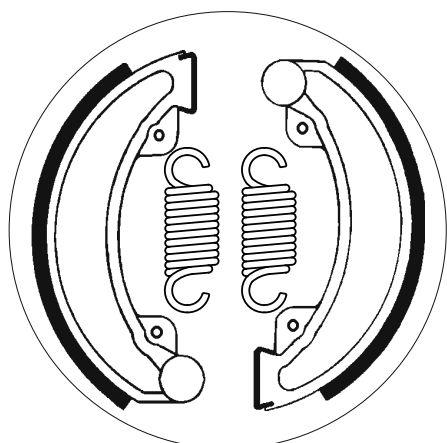

HONDA			
CR	250 R	81 - 82	•
XR	250 R	81 - 83	•
CR	450 R	81 - 81	•
CR	480 R	82 - 82	•
XR	500 R Pro Link	81 - 82	•

ø140 x 25

SBS 2031

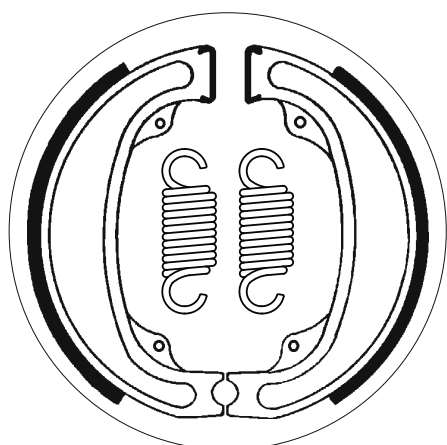

HONDA			
CR	125 R	79 - 81	•
CR	250 RZ, RA	79 - 80	•
XR	500 SZ, SA	79 - 80	•

ø110 x 25

SBS 2032

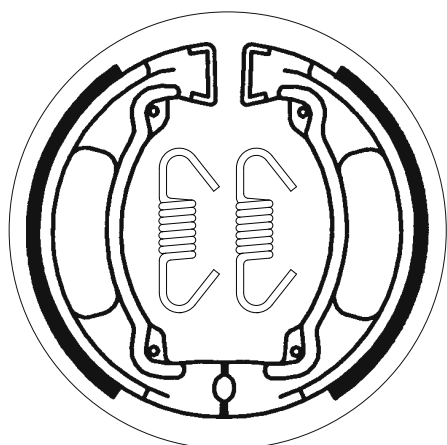

CPI			
	50 Popcorn	03 - 06	•
GARELLI			
SR	50 Pony	95 - 02	•
YAMAHA			
DT	50 M, MX	78 - 86	• •
FS	50 DX	75 - 79	•
FS1	50 DX	77 - 81	•
FS1	50 E	74 - 76	• •
FS1	50 SE	81 - 82	• •
LB	50 Chappy	80 - 83	• •
RD	50	76 - 78	• •
RD	50 M	79 - 80	•
RD	50 MX	81 - 87	•
RX	50 K	83 - 85	•
TY	50 , M	77 - 80	• •
V	50 M, P	74 - 82	• •

YAMAHA			
YSR	50	92 - 92	•
RD	60	73 - 75	• •
V	70 A	76 - 76	• •
V	75 A	77 - 77	• •
DT	80 MX	81 - 83	• •
LB2	80 Bop 2	80 - 80	• •
RD	80 LC	81 - 85	•
RD	80 MX	81 - 86	•
RX	80 SE	82 - 84	•
TY	80	77 - 82	• •
V	80	79 - 82	• •
YZ	80	74 - 79	•
V	90	78 - 78	• •
YA	90 Axis	90 - 93	•
AG	100 Farmbike	80 - 91	•
DT	100	76 - 80	• •
RS	100	75 - 80	• •
RX	100	76 - 79	•



YAMAHA			
RX	100	84 - 87	•
YB	100	78 - 81	• •
YB	100	82 - 86	•
YZ	100	78 - 81	•
RX	115 S	82 - 85	•
IT	125 G, H, J	80 - 82	•
TY	125	80 - 82	•
YZ	125	74 - 75	•
TY	175	77 - 80	•
TY	250	77 - 78	•
TY	250	84 - 90	•
TY	250 R	91 - 92	•
BW	350	87 - 88	•
TY	350	86 - 86	•

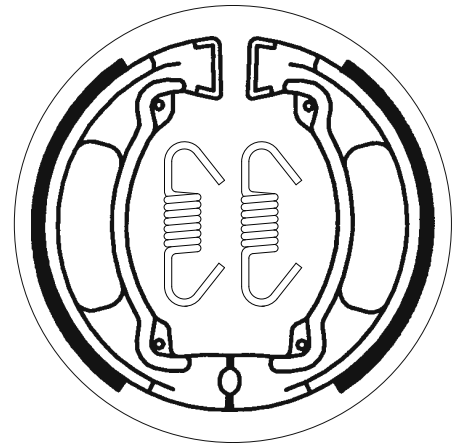

YAMAHA			
YZ	125	76 - 83	•
IT	175	80 - 82	•
IT	250	80 - 82	•
TY	250	81 - 81	•
YZ	250	74 - 81	•
YZ	400	77 - 79	•
IT	425	80 - 80	•
IT	500 G, H.	80 - 81	•

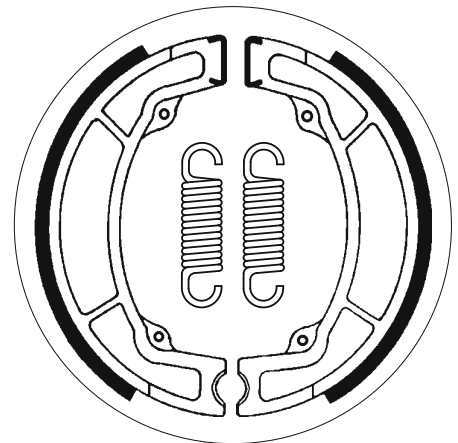

PEUGEOT			
	125 Tweet	10 - 13	•
	150 Tweet	10 - 13	•
YAMAHA			
YFM	50 Raptor	04 - 11	•
DT	80 LC	81 - 84	•
DT	80 LC-2	85 - 92	•
TZR	80	89 - 91	•
VN	80 NW	88 - 88	•
YFM	80	87 - 88	•
YFM	80	92 - 94	•
YFM	80 Badger	95 - 07	•
YFM	80 Grizzly	05 - 08	•
YFM	80 N, S Moto 4	85 - 86	•
YFM	80 Raptor	02 - 08	•
	100 Aerox	00 - 06	•
	100 Neo's	00 - 02	•
AG	100 Farmbike	80 - 93	•



YAMAHA			
DT	100	76 - 80	•
YFM	100 Champ	87 - 91	•
YZ	100	78 - 83	•
BL	125 Beluga	85 - 87	•
BL	125 Beluga	88 - 93	•
DT	125 E, MX, LC	74 - 85	•
DT	125 LC	85 - 87	•
DT	125 MX	90 - 93	•
DT	125 Tenere	89 - 90	•
IT	125 G, H, J	80 - 82	•
RD	125 DX	75 - 77	•
RD	125 LC	82 - 87	•
RS	125 DX	76 - 86	•
SR	125 SE	82 - 82	•
TY	125	80 - 82	•
TZR	125	87 - 88	•
XC	125 Beluga	85 - 85	•
XC	125 Beluga, Riva	87 - 92	•

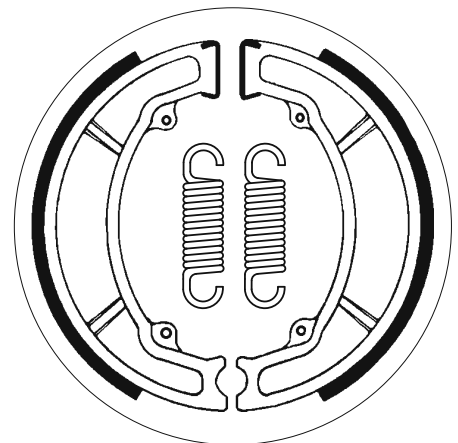





**YAMAHA**

YZ	125	84 - 84	•
IT	250	84 - 84	•
YZ	250	82 - 84	•
IT	465	81 - 82	•
YZ	465	80 - 81	•
IT	490	84 - 84	•
YZ	490	81 - 84	•
TT	600 K,L	83 - 84	•

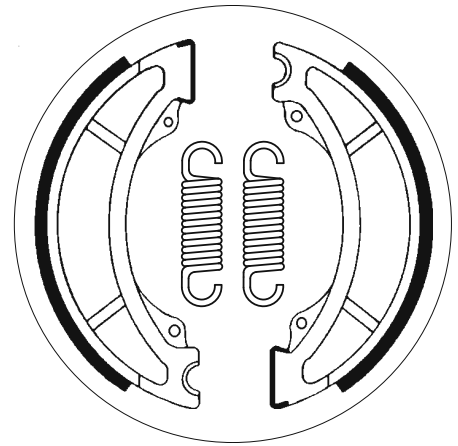

**YAMAHA**

RD	125 DX	78 - 81	•
YP	125	89 - 89	•
XC	180 Cygnus, Riva	83 - 85	•
RD	200 A, B	74 - 75	•
RD	200 DX	76 - 81	•
RS	200	79 - 79	•
DT	250 all models	75 - 80	•
IT	250	80 - 82	•
IT	250	84 - 86	•
SRX	250 T, TC	87 - 87	•
TY	250	81 - 81	•
YD	250	86 - 86	•
YZ	250	81 - 81	•
DT	400 all models	75 - 77	•
SR	400	76 - 76	•
IT	465	81 - 82	•
YZ	465	81 - 81	•
IT	490	84 - 84	•



**YAMAHA**

YZ	490	81 - 82	•
YZ	490	84 - 90	•
SR	500	78 - 98	•
XT	500 (Austria)	83 - 83	•
XT	500	76 - 80	•
XT	500	86 - 89	•
XT	550	82 - 83	•
XT	600	83 - 86	•
XT	600 Tenere	83 - 84	•
XT	600 Z	86 - 88	•

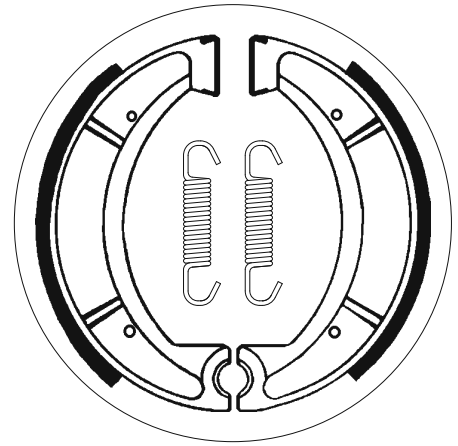

**KAWASAKI**

KLF	185 Bayou	85 - 88	•
KLF	220 Bayou	88 - 02	•
BR	250	86 - 90	•
EL	250	91 - 94	•
EL	250 Eliminator	88 - 89	•
GPZ	250	83 - 85	•
GPZ	250 Belt Drive	83 - 84	•
KLF	250 Bayou	03 - 11	•
KLR	250	84 - 05	•
Z	250	80 - 83	•
Z	250 T, Scorpion	89 - 89	•
EL	252	97 - 03	•
KLF	300 A1, A2 Bayou	86 - 87	•
KLF	300 Bayou	88 - 04	•
EX	305	83 - 83	•
GPZ	305	81 - 96	•
KZ	305	81 - 82	•
KZ	305	87 - 88	•



**KAWASAKI**

Z	305	81 - 82	•
GPZ	400 S	88 - 90	•
KZ	400	78 - 79	•
KZ	400 H1 (LTD)	79 - 79	•
Z	400	78 - 79	•
Z	400 D, S	76 - 77	•
Z	400 F	84 - 86	•
ZR	400 F	83 - 84	•
KZ	440, LTD	83 - 85	•
KZ	440	80 - 83	•
KZ	440 C	80 - 81	•
KZ	440 C, Twin	81 - 83	•
KZ	440 LTD	80 - 82	•
Z	440 C	80 - 81	•
Z	440 C, Twin	81 - 83	•
Z	440 LTD	80 - 84	•
ER-5	500	97 - 07	•
EX	500	87 - 93	•

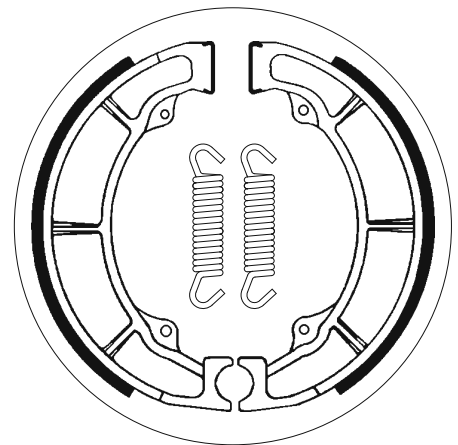

ø160 x 30

SBS 2038

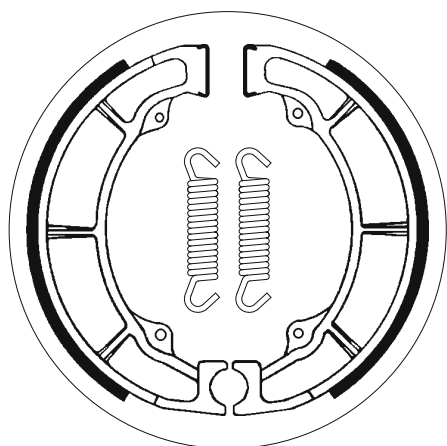

KAWASAKI			
	500	93 - 95	•
GPZ	500 S	87 - 88	•
GPZ	500 S (Austria)	87 - 93	•
ZR	500 (Z 500 F)	83 - 87	•
Z	550 F	83 - 88	•
ZR	550 A1, GP	83 - 84	•
W	650	99 - 05	•

ø120 x 28

SBS 2039

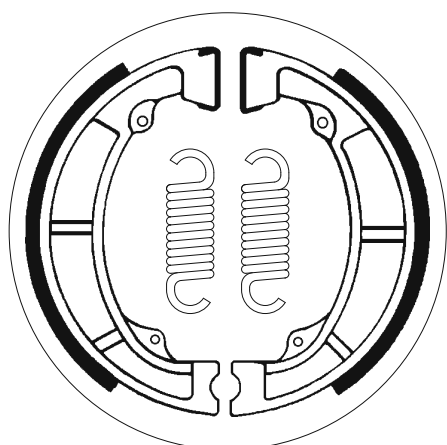

KAWASAKI			
KE	125	76 - 85	•
KX	125	74 - 81	•
KDX	175	80 - 82	•
KE	175	76 - 83	•
KL	250	80 - 84	•
KLX	250	79 - 80	•
KT	250 all models	75 - 80	•

ø140 x 28

SBS 2040

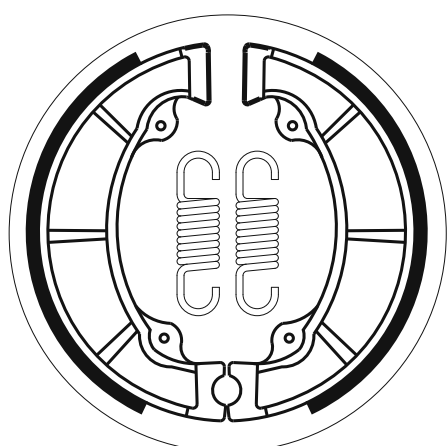

KAWASAKI			
KLF	185 Bayou	86 - 88	•
KLT	200	81 - 84	•
KLF	220 Bayou	88 - 02	•
KDX	250	80 - 84	•
KL	250	78 - 80	•
KLF	250 Bayou	03 - 11	•
KLT	250	82 - 83	•
KLT	250 Police	84 - 84	•
KLT	250 Prairie	83 - 85	•
KX	250	75 - 81	•
KXT	250 Tecate	84 - 84	•
KX	420	80 - 81	•

**SBS 2041**

**ø130 x 25**



<b>BOMBARDIER</b>		
50 Quest	03 - 04	•
DS 50	02 - 06	•
90 Quest	03 - 04	•
DS 90	02 - 06	•
<b>CAN-AM</b>		
DS 50	07 - 11	•
DS 70	08 - 14	•
DS 90	07 - 17	•
<b>HONDA</b>		
TRX 70	86 - 87	•
CB 125 S	84 - 85	•
CG 125 E, F, J	85 - 91	•
CH 125 Spacy	94 - 01	•
CR 125 R	79 - 81	•
CR 125 RC	82 - 82	•
CH 250 Elite	85 - 86	•



<b>HONDA</b>		
CH 250 Elite	87 - 90	•
CH 250 Spacy, Freeway		
Fusion	88 - 93	•
CN 250	93 - 04	•
CN 250 Spazio	88 - 89	•
CR 250 R	81 - 82	•
XL 250 R	82 - 83	•
CR 480 R	82 - 82	•

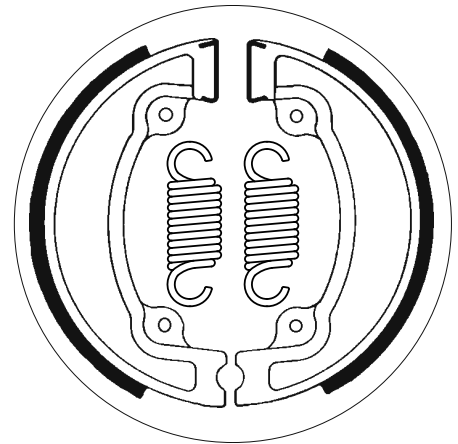

**SBS 2042**

**ø130 x 22**



<b>HONDA</b>		
CR 125 RD	83 - 83	•
CR 125 RE, RF	84 - 85	•
MBX 125 RWB	84 - 86	•
CR 250 R	83 - 83	•
CR 250 RE, RF	84 - 85	•
XR 350 R	83 - 83	•
CR 480 R	83 - 83	•
CR 500 RE, RF	84 - 85	•

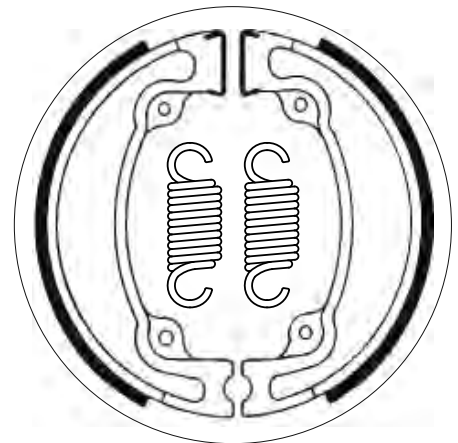

**SBS 2043**

**ø86 x 20**



<b>AEON</b>		
100 Revo 2	04 - 06	•
<b>HONDA</b>		
CR 80 R	86 - 91	•
CR 80 RF	85 - 85	•
MB 80	80 - 83	•
<b>POLARIS</b>		
90 Predator	03 - 14	•

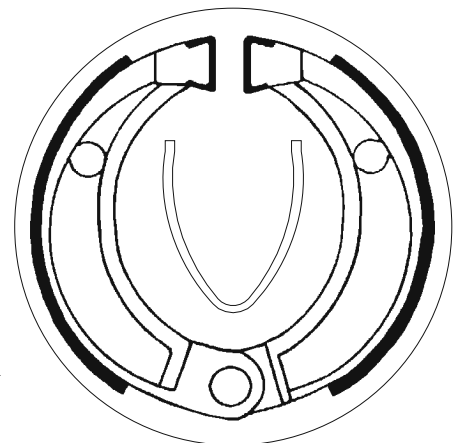

Dimensions in mm / Dimensions en mm  
1" = 25.4 mm , 1 mm = 0.04"



ø160 x 30

SBS 2044

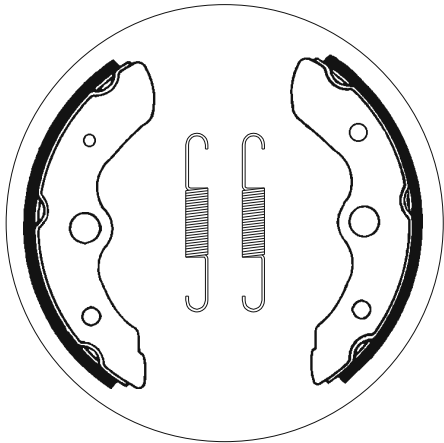

HONDA			
TRX	200	84 - 84	•
TRX	250	85 - 87	•
FL	350 R Odyssey	85 - 87	•
FL	400 R Pilot	89 - 90	•

ø160 x 30

SBS 2045

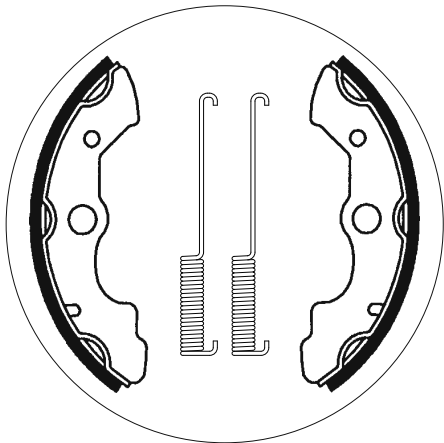

HONDA			
TRX	350 all models	86 - 89	•

ø180 x 35

SBS 2046

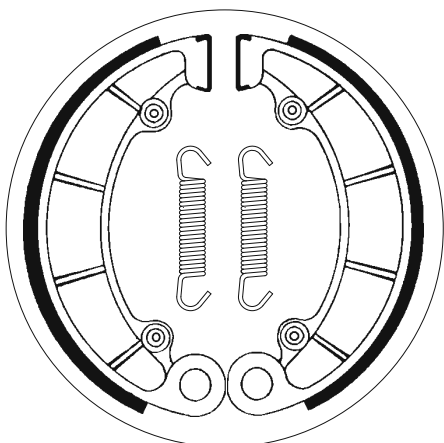

HONDA			
TRX	350 all models	86 - 89	•
TRX	500 all models	05 - 14	•
CB	700 SC	84 - 86	•
VF	700 C Magna	85 - 87	•
VT	700 C Shadow	86 - 86	•
VT	700 C, Shadow	87 - 87	•
VF	750 C, CD Magna	94 - 98	•
VF	750 C, Magna	88 - 93	•
VP	750 CH, Custom	87 - 87	•
VT	750 Black Widow	01 - 03	•
VT	750 C, Shadow	86 - 96	•
VT	750 C2 Shadow A.C.E.	97 - 03	•
VT	750 C2 Shadow Spirit	07 - 11	•
VT	750 C4 Shadow	04 - 05	•
PC	800 Pacific Coast	89 - 97	•
VT	800 C	88 - 94	•
VT	1000 C	88 - 88	•
VT	1100 C Shadow	87 - 96	•

SBS 2047

ø130 x 25



**HONDA**

CR	125 RG	86 - 86	•
CR	250 RG	86 - 86	•
CR	500 RG	86 - 86	•

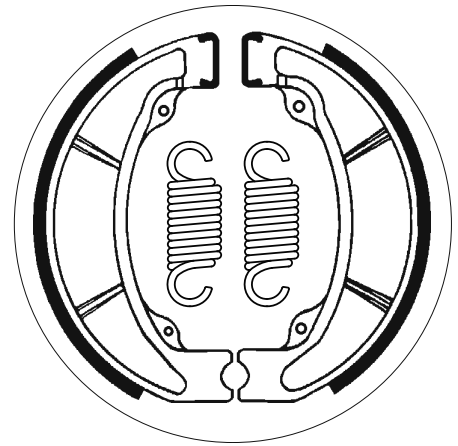

SBS 2048

ø87 x 20



**ARCTIC CAT**

50	2WD	04 - 06	•
50	DVX	06 - 08	•
90	2WD	02 - 04	•
90	DVX	06 - 14	•

**BOMBARDIER**

DS	50	02 - 06	•
DS	90	02 - 06	•

**CAN-AM**

DS	50	07 - 11	•
DS	70	08 - 14	•
DS	90	07 - 17	•

**HONDA**

TRX	70	86 - 87	•
-----	----	---------	---

**POLARIS**

50	Predator	04 - 14	•
50	Scrambler	01 - 03	•
90	Scrambler	01 - 03	•
90	Sportsman	01 - 15	•

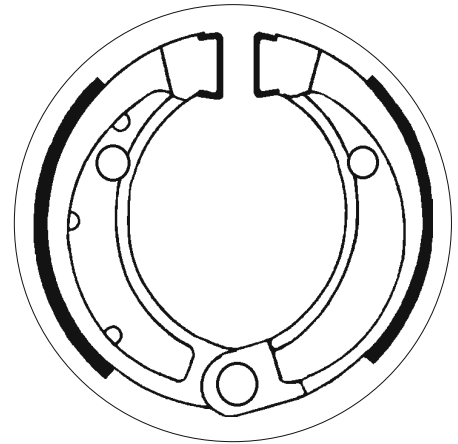

SBS 2049

ø130 x 22



**YAMAHA**

YZ	125	83 - 87	•
IT	200	84 - 85	•
IT	200	85 - 86	•
TY	250	84 - 90	•
BW	350	87 - 88	•
TY	350	86 - 86	•

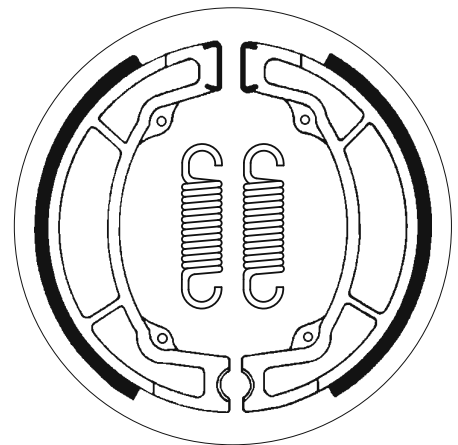

Brake Shoe  
Drawings, Fitments

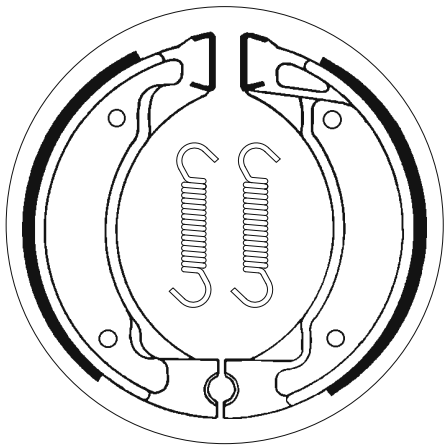

<b>APRILIA</b>			
50 Amico, Scooter	92 - 92	•	
<b>MBK</b>			
50 Booster	90 - 94	•	•
50 Booster Next Gen.	97 - 06	•	•
50 Booster Rocket	95 - 02	•	•
50 Booster Spirit	00 - 16	•	•
50 Booster Track	97 - 02	•	•
50 Evolis	92 - 98	•	•
50 Flipper	99 - 04	•	•
50 Hot Champ	91 - 97	•	•
50 Ovetto	97 - 10	•	•
75 Active	90 - 90	•	•
<b>YAMAHA</b>			
50 Beluga	90 - 92	•	•
50 Why	99 - 07	•	•
BW 50	91 - 94	•	•
BW 50 Bump	97 - 02	•	•
BW 50 Next Generation	96 - 07	•	•
BW 50 Spy	95 - 03	•	•
CR 50 Z	91 - 95	•	•
CW 50 TA Zuma	90 - 90	•	•
DT 50 MX	87 - 90	•	•
DT 50 R	89 - 97	•	•
JOG 50 CY	90 - 92	•	•
JOG 50 R	02 - 07	•	•
T 50	86 - 89	•	•
TRAFIC 50 M	83 - 83	•	•
V 50 M	83 - 83	•	•
YA 50 Axis Mofa	97 - 02	•	•
YM 50 Breeze, Fizz	95 - 95	•	•
YN 50 Neo's, LC	97 - 16	•	•
YF 60 S Moto 4	86 - 86	•	•
YT 60 Tri Zinger	84 - 85	•	•
CH 80 Beluga (CH 80)	90 - 90	•	•
DT 80 MX, MXS	84 - 85	•	•
PW 80	83 - 85	•	•
T 80 Townmate	83 - 97	•	•
V 80 DL	83 - 83	•	•
YFM 80	87 - 88	•	•
AG 100 Farmbike	92 - 93	•	•
RXS 100	83 - 97	•	•
YFM 100 Champ	87 - 88	•	•

<b>YAMAHA</b>			
105 Crypton	98 - 04	•	•
SR 125	92 - 02	•	•
Y 125 Fair Breeze	92 - 95	•	•

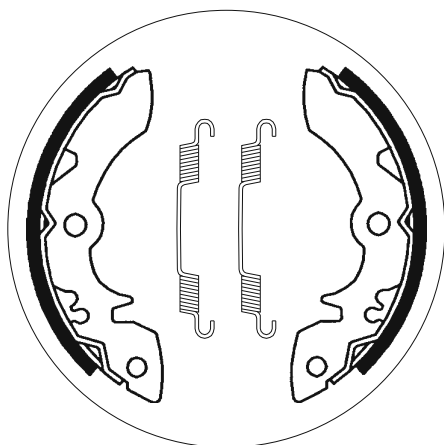

<b>SUZUKI</b>			
LT 230	85 - 86	•	•
LT-F 230	86 - 87	•	•
LT 250	85 - 86	•	•
LT 300	87 - 89	•	•
LT-F 300	88 - 90	•	•



<b>SUZUKI</b>			
LT-F	280 4WD	91 - 98	•
LT-F	300	88 - 90	•
LT-F	300 King Quad	91 - 01	•
LT-F	300 King Quad Left/Rear	02 - 02	•
VS	600 GL Intruder	97 - 97	•
GV	700 GLG Madura	86 - 86	•
VS	700 GLFG	86 - 87	•
VS	750 Intruder	86 - 91	•
C	800 Intruder	05 - 18	•
M	800 Intruder	05 - 18	•
VL	800 Intruder LC Volusia	01 - 04	•
VS	800 Intruder	91 - 99	•
VZ	800 Marauder	97 - 04	•

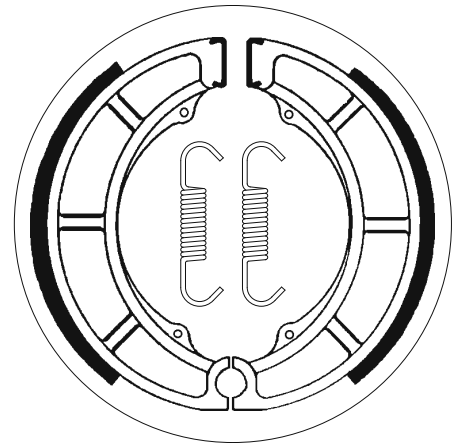

<b>KAWASAKI</b>			
KAF	300 Mule 500	92 - 95	•
KAF	300 Mule 550	03 - 05	•
<b>SUZUKI</b>			
LT	250 4WD	87 - 98	•
LT-F	250	88 - 01	•
LT-F	250 4WD V, W Quadrunner	97 - 98	•

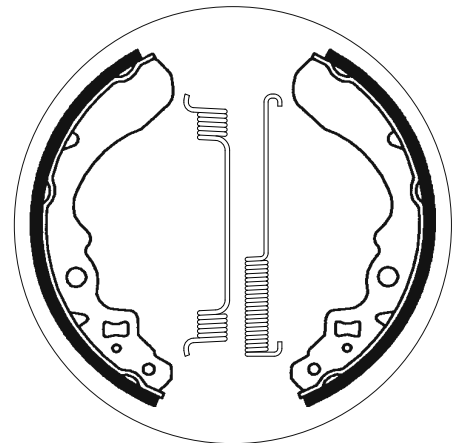

<b>KAWASAKI</b>			
KLF	300 A1, A2 Bayou	86 - 87	•

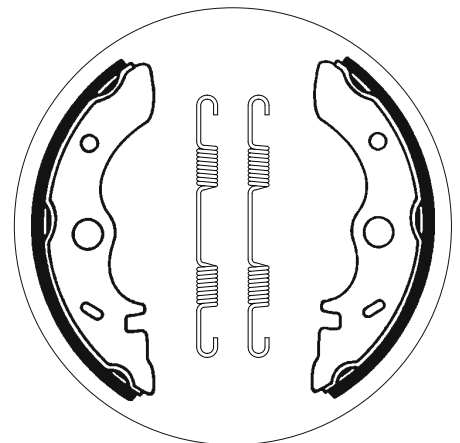

ø140 x 30

SBS 2055

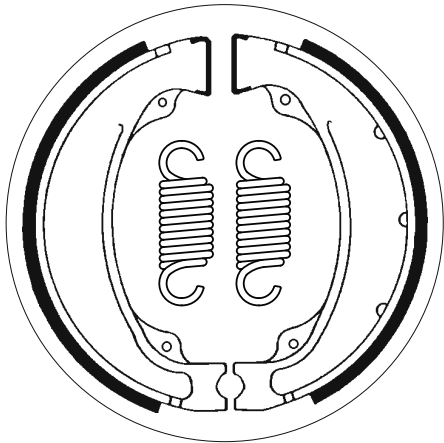

HONDA			
TRX	250 EX Sportrax	01 - 08	•
TRX	250 Recon	97 - 21	•
TRX	250 X	08 - 13	•
XBR	500 S	85 - 89	•
XLV	750 R	83 - 88	•

ø120 x 35

SBS 2056

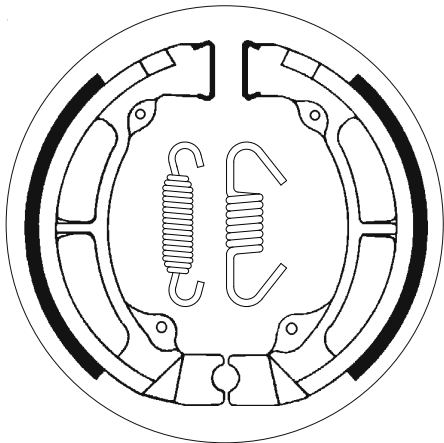

KAWASAKI			
KE	175	79 - 83	•
KDX	200	83 - 85	•
KL	250 (KLR 250)	85 - 97	•
KL	250	80 - 84	•

ø95 x 20

SBS 2057

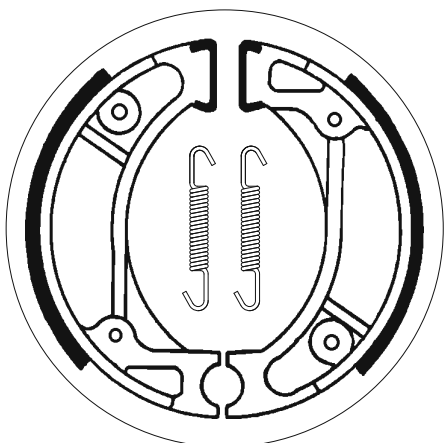

BS VILLA			
ZX	50	93 - 93	•
HONDA			
	50 Dio, Life	94 - 96	• •
	50 Super Dio (Japan)	94 - 96	• •
CH	50 P Metropolitan II	02 - 06	• •
CHF	50 Metropolitan	02 - 05	• •
CR	50 RE, RF	84 - 85	• •
GP	50 Dio	91 - 91	•
HSC	50 ZR, 01 Scooter	92 - 95	•
NPS	50 Zoomer	01 - 12	• •
NU	50 MC Runaway,		
	Express	82 - 83	• •
PK	50 Walaroo DX-STD	90 - 01	•
QR	50	93 - 03	•
SA	50 J Vision	88 - 94	• •
SR	50 Dio	93 - 93	•
SR	50 Super Dio	91 - 92	•

HONDA			
SZ	50 Tact S	93 - 96	•
TLM	50 F	85 - 85	• •
ZX	50 Super Dio	92 - 01	•
CR	60 RF, RG	85 - 86	• •
CRF	70 F	04 - 14	• •
XR	70	97 - 12	• •
SA	75 Vision	89 - 92	•
CH	80 Elite	85 - 88	•
CR	80 RC	82 - 82	•
CR	80 RD, RE	83 - 84	• •
CR	80 RF	85 - 85	•
CRF	80 F	04 - 14	• •
NH	80 Aero	85 - 85	•
XR	80 R	85 - 88	• •
CRF	100 F	04 - 14	• •
XR	100 R	85 - 03	• •
CRF	110 F	13 - 24	• •
CRF	125 F	14 - 24	•

SBS 2057

ø95 x 20



HONDA			
TLR	200 D, E, F	83 - 85	• •
TLR	200 G, H	86 - 87	•
KYMCO			
CX	50	94 - 97	•
CX	50 Curio Super	94 - 97	•
DJ	50	99 - 02	•
DJ	50 Refined	99 - 02	•
DJW	50	94 - 97	•
DJX	50	91 - 92	•
DJY	50	93 - 06	•
ZX	50 Fever	96 - 01	•
SYM			
	50 Mio	05 - 16	•
DD	50	02 - 12	•

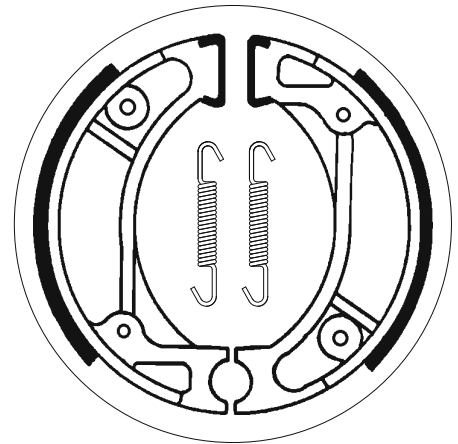

SBS 2058

ø140 x 40



HONDA			
CA	250 Rebel	90 - 95	•
CB	250	88 - 05	•
CB	250 N	78 - 81	•
CB	250 NA, NB, T, TZ	77 - 81	•
CM	250 TB	81 - 81	•
CB	350 S.G. (U.K. only)	87 - 90	•
CB	400 A	77 - 81	•
CB	400 Four	81 - 85	•
CB	400 N	78 - 86	•
CB	400 N, T, Hawk	78 - 82	•
CB	400 T1, T2	77 - 78	•
CB	400 Twin	82 - 86	•
CM	400 A, T, TZ	79 - 79	•
CM	400 C	81 - 81	•
CM	400 E	80 - 81	•
CM	400 T	79 - 84	•
GB	400 T.T.	88 - 92	•
CB	450 N	84 - 89	•



HONDA			
CB	450 S	86 - 88	•
CB	450 SC Nighthawk	82 - 86	•
CB	450 T	82 - 86	•
CM	450 A, C	82 - 86	•
CMX	450 Rebel	86 - 88	•
VT	500 C Shadow	83 - 86	•
VT	500 E	83 - 85	•
VT	500 ED	82 - 82	•
CB	550 SC	83 - 84	•

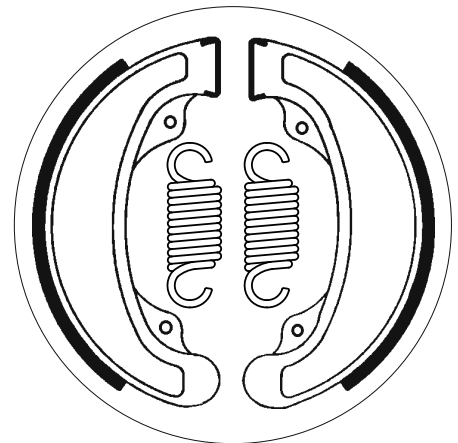

SBS 2059

ø160 x 40



HONDA			
CB	500	94 - 96	•
CX	500	78 - 80	•
CX	500 C	81 - 82	•
CX	500 Z, A, B	79 - 81	•
GB	500 T.T.	88 - 92	•
GL	500 D	81 - 82	•
GL	500 I	81 - 82	•
NV	600 C	88 - 96	•
VT	600 C, Shadow	88 - 00	•
VT	600 CD Shadow VLX	94 - 00	•
CB	650 SC Nighthawk	83 - 85	•
CBX	650 E	83 - 90	•
CBX	650 ED, SC, SCD	83 - 83	•
CX	650 C	83 - 86	•
GL	650 D	83 - 84	•
VF	700 C Magna	84 - 84	•
VF	700 S	84 - 85	•
VT	700 C Shadow	84 - 85	•



HONDA			
CB	750 Nighthawk	91 - 02	•
VF	750 C	82 - 84	•
VF	750 S	85 - 85	•
VF	750 Sport	82 - 83	•
VT	750 C	83 - 85	•

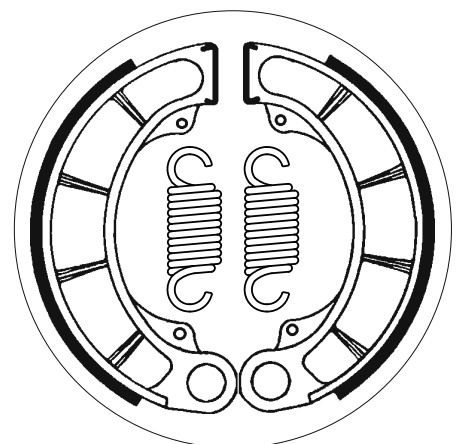

Dimensions in mm / Dimensions en mm  
1" = 25.4 mm , 1 mm = 0.04"

Ø180 x 40

SBS 2060

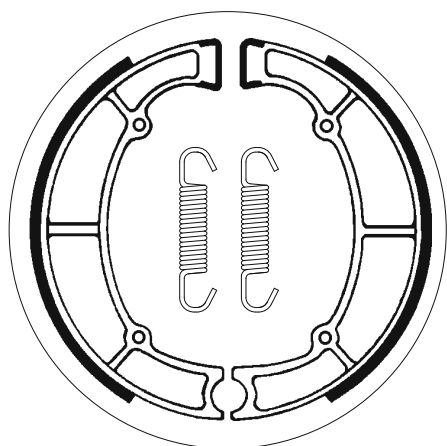

<b>KAWASAKI</b>			
EN	400 Twin	85 - 89	•
Z	400 J	80 - 85	•
Z	400 T (Belt Drive)	83 - 85	•
EN	450	85 - 90	•
Z	450 LTD	84 - 89	•
EN	500	90 - 96	•
EN	500	98 - 04	•
EN	500 Vulcan	96 - 97	•
ZL	500 (Austria)	85 - 90	•
GT	550	85 - 01	•
KZ	550	80 - 84	•
KZ	550 A1	80 - 80	•
Z	550	80 - 85	•
Z	550 C3, LTD	82 - 84	•
Z	550 GT	83 - 01	•
Z	550 GT, LTD	82 - 85	•
Z	550 LTD	81 - 85	•
Z	550 M1, LTD	83 - 86	•
ZL	600	85 - 91	•
ZL	600 B2 Eliminator	95 - 98	•
KZ	650	77 - 84	•
KZ	650 F	81 - 84	•
Z	650	77 - 84	•
Z	650 F	81 - 84	•
VN	700 Vulcan	85 - 85	•
	750 Vulcan	93 - 94	•
KZ	750	83 - 84	•
KZ	750 LTD	80 - 81	•
KZ	750 M1	82 - 85	•
VN	750 Vulcan	86 - 94	•
VZ	750 Twin	88 - 88	•
Z	750	83 - 83	•
Z	750 LTD	80 - 80	•
Z	750 M1	82 - 85	•
VN	800 Classic	98 - 99	•
VN	800 Vulcan Classic	96 - 06	•
VN	800 Vulcan, Classic	95 - 97	•

Ø180 x 40

SBS 2063

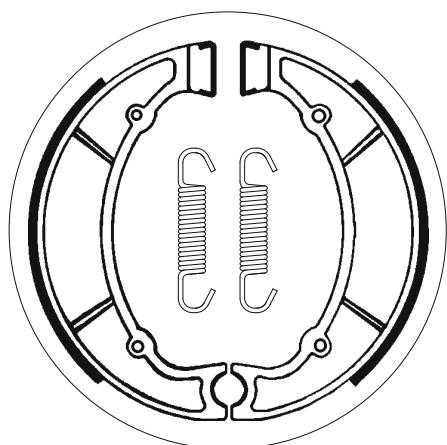

<b>YAMAHA</b>			
XJ	400 Maxim, Seca	81 - 81	•
XT	400	86 - 86	•
TX	500 A, B	74 - 77	•
XS	500	75 - 77	•
XV	500 K, Virago	83 - 83	•
XV	500 SE	83 - 83	•
XJ	550 Maxim	81 - 83	•
XZ	550	82 - 84	•
XZ	550 RJ, RK	82 - 83	•
XZ	550 S	83 - 84	•
YX	600 Radian	87 - 90	•
XV	750 MK	83 - 83	•
XV	750 SE	81 - 83	•

SBS 2064

ø180 x 30



YAMAHA			
YDS-7	200	73 - 75	•
RD	250	73 - 77	•
RD	250 DX Left/Rear	80 - 80	•
RD	250 LC	80 - 82	•
RD	350	73 - 79	•
RD	350 LC	80 - 82	•
XS	360 B	76 - 76	•
XS	650	75 - 79	•
XS	650 SJ, SK	82 - 82	•

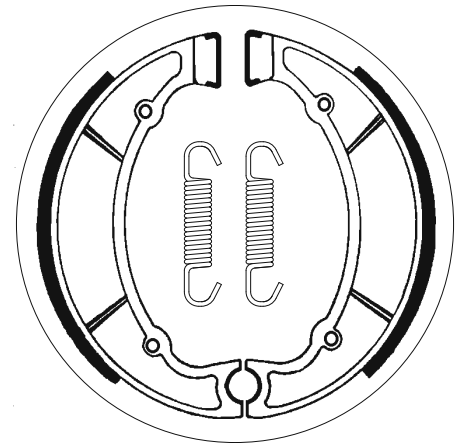

SBS 2065

ø200 x 40



YAMAHA			
XV	400 Virago, SPL	88 - 88	•
XV	535 DX Virago	98 - 03	•
XV	535 S Virago	96 - 03	•
XV	535 Virago	87 - 97	•
XJ	650	80 - 83	•
XJ	650 G, H, SH Left/Rear	80 - 83	•
XJ	650 RJ Seca	81 - 83	•
XJ	650 Turbo	81 - 82	•
XVS	650 A Drag Star Classic	98 - 06	•
XVS	650 Drag Star	97 - 06	•
XVS	650 V-Star Classic	98 - 06	•
XVS	650 V-Star Custom	98 - 06	•
XJ	700	86 - 89	•
XV	700 L, LC	84 - 87	•
XV	700 Virago	87 - 87	•
TX	750	73 - 74	•
VF	750 Virago	88 - 88	•
XJ	750 E	81 - 83	•



YAMAHA			
XJ	750 Maxim	82 - 82	•
XJ	750 Seca	81 - 83	•
XV	750	89 - 92	•
XV	750 Virago	93 - 97	•
XV	920 J	82 - 82	•
XV	1000 SE	83 - 85	•
XV	1000 TR1	81 - 83	•
XV	1000 Virago	86 - 88	•
XV	1100	94 - 97	•
XV	1100 Virago	86 - 98	•

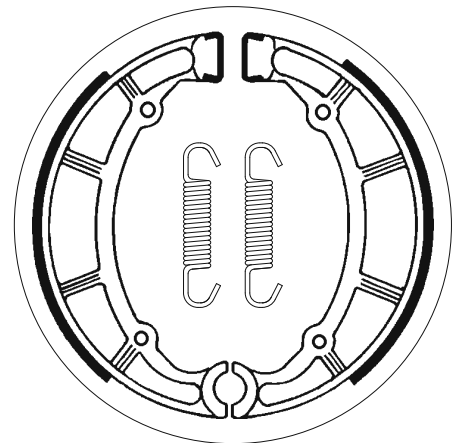

SBS 2066

ø160 x 30



YAMAHA			
XS	250 C	81 - 81	•
XS	250 D, E	79 - 80	•
XS	250 SE, SF	80 - 81	•
YP	250 Majesty	96 - 04	•
YFM	350 Big Bear Special Edition	99 - 99	•
YFM	350 FWB L, LC Big Bear	99 - 99	•
YFM	350 FWH, FWJ, FWK Big Bear	96 - 98	•
YFM	350 UH, UJ, UK	96 - 98	•
XS	400	78 - 83	•
XS	400	85 - 85	•
XS	400 DOHC	82 - 82	•
XS	400 SE Left/Rear	80 - 81	•
XS	400 SG, SH, SF	80 - 81	•
YFM	400 FAR Kodiak Automatic	03 - 03	•
YFM	400 Kodiak	93 - 99	•



YAMAHA			
XJ	500 (Austria)	81 - 83	•
XJ	550 Seca	81 - 83	•
YFM	600 4x4 Grizzly	98 - 01	•

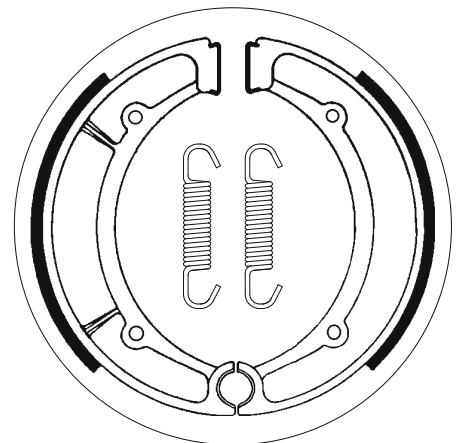

Dimensions in mm / Dimensions en mm  
1" = 25.4 mm , 1 mm = 0.04"



ø140 x 30

SBS 2068

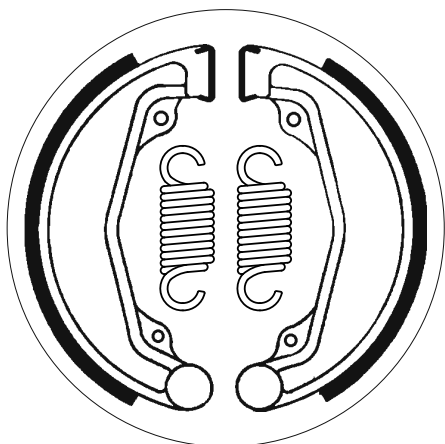

HONDA			
CB	175 K3-K7	74 - 76	•
CB	200 B, T	74 - 79	•
CB	250 RS	80 - 85	•
CL	250 SC	81 - 81	•
VT	250 F	83 - 90	•
VTR	250	88 - 90	•
VTZ	250	88 - 99	•
XL	500 SB	81 - 81	•

ø130 x 30

SBS 2069

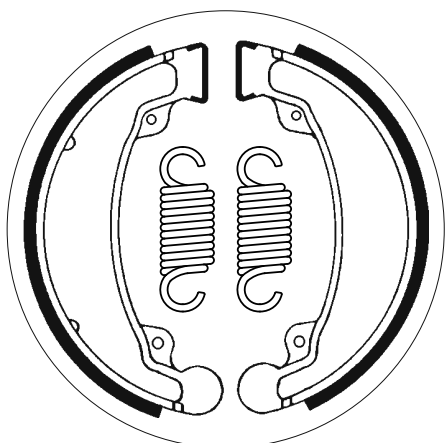

DAELIM			
	50 Delfino	99 - 99	•
	50 Tapo	99 - 04	•
	50 Vivo	99 - 99	•
	100 Delfino	99 - 04	•
	125 Rocket	99 - 01	•
HONDA			
	ATC 70 all models	78 - 85	•
	CB 125 RS	83 - 83	•
	CB 125 T	85 - 85	•
	CB 125 T, Superdream	82 - 83	•
	CB 125 T, T1, T2, TZ	77 - 81	•
	CB 125 TDC	83 - 89	•
	CB 125 TT	90 - 90	•
	CD 125	82 - 82	•
	CM 125	82 - 85	•

HONDA			
	CD 185 T	78 - 82	•
	CM 185 T	78 - 79	•
	CD 200 T	79 - 79	•
	CM 200 TA, TB	80 - 82	•
	CB 250 Nighthawk	91 - 02	•
	CD 250 UJ	88 - 92	•
	CM 250 C	82 - 83	•
	CMX 250 C Rebel	96 - 00	•
	CMX 250 Rebel	85 - 12	•

ø160 x 25

SBS 2070

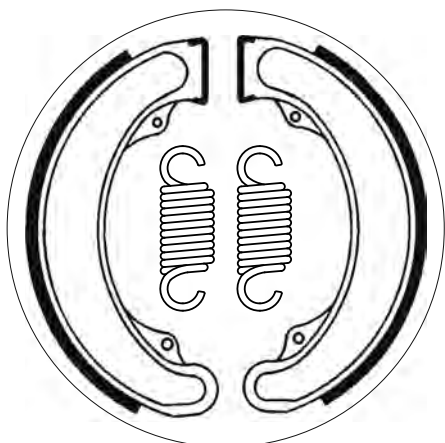

HONDA			
	XL 250	78 - 79	•
	XL 350	76 - 78	•

**SBS 2071****ø180 x 30****HONDA**

CB	250 K3-K5	73 - 75	•
CB	350 K4	74 - 74	•
CM	400 E	80 - 81	•

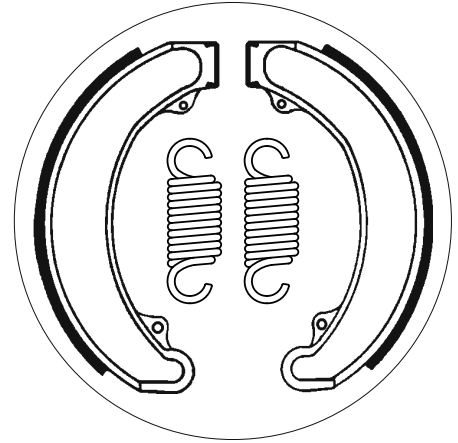
**SBS 2072****ø180 x 30****HONDA**

CB	450 K5, K6, K7	72 - 77	•
CB	500 F	72 - 75	•
CB	500 T	75 - 78	•
TRX	500 Foreman, Rubicon	00 - 09	•
CB	550 F	75 - 79	•
CB	550 K	74 - 78	•

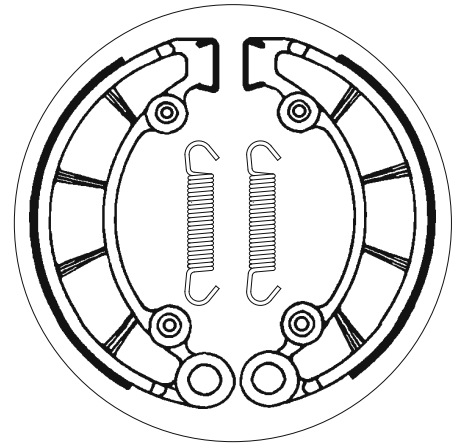
**SBS 2074****ø80 x 18****HONDA**

PA	50	78 - 81	•
PA	50 Camino	80 - 86	•
PF	50 M Nocio	75 - 80	•
PX	50	82 - 84	•
QA	50 K1-K3	87 - 89	•

**KTM**

SX	50 Adventure	98 - 03	•
SX	50 Pro Junior LC	02 - 05	•
SX	50 Pro Senior LC	02 - 03	•
SX	50 Senior Adventure	04 - 07	•

**MOTOBECANE**

50	all models	88 - 89	•
----	------------	---------	---

**PEUGEOT**

50	103	71 - 75	•
50	104	76 - 76	•

**PEUGEOT**

50	105	82 - 82	•
----	-----	---------	---

**PUCH**

50	Cobra 6 GT, GTL	80 - 84	•
50	Maxi 30 all models (excl. Spain)	69 - 80	•
50	Maxi 40 all models	69 - 80	•
50	Monza 4 GP, all models	79 - 83	•
50	Monza 4 SL	79 - 79	•
50	Monza 4 SL, GSL	80 - 83	•

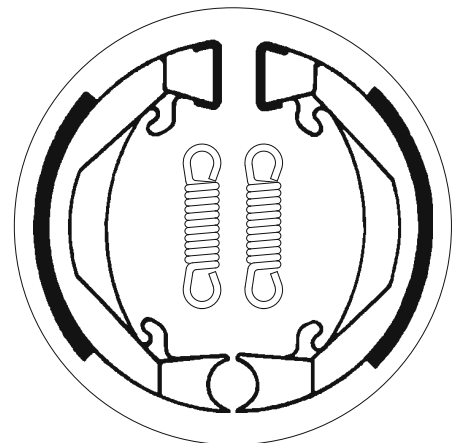

Dimensions in mm / Dimensions en mm  
1" = 25.4 mm , 1 mm = 0.04"

ø160 x 25

SBS 2075

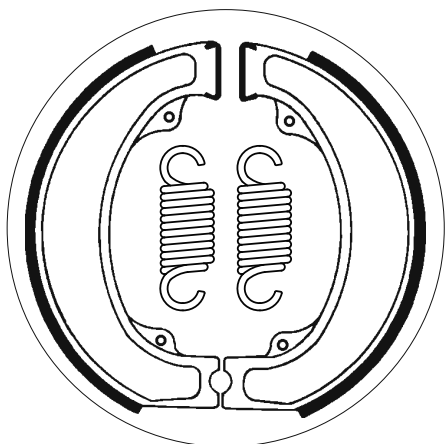

HONDA			
CR	250 RZ, RA	79 - 80	•
XL	500 SB	81 - 81	•

ø130 x 25

SBS 2077

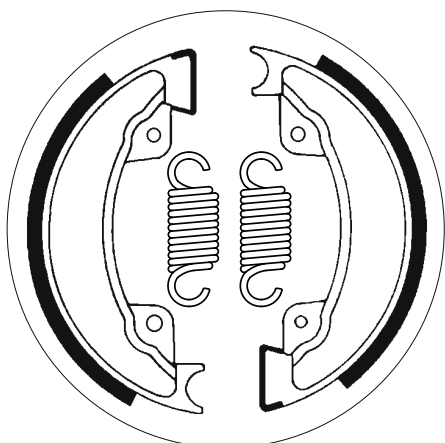

HONDA			
XLR	400	83 - 83	•
XL	500 RC	82 - 82	•

ø110 x 25

SBS 2080

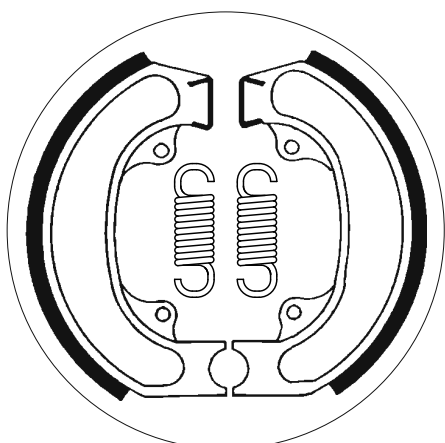

HONDA			
SH	50 City Express	84 - 96	•
SH	50 Scoopy	88 - 04	•
SH	75 Scoopy	88 - 95	•
SH	80 Scoopy	88 - 93	•

SBS 2082

ø130 x 25



HONDA

CH	250 Elite	85 - 86	•
CH	250 Spacy	85 - 86	•
CN	250 Helix (Fusion)	92 - 03	•

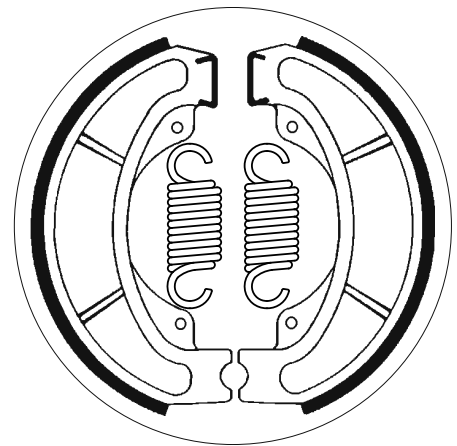

SBS 2083

ø130 x 26



HONDA

TRX	200	90 - 91	•
TRX	200 D Type II	91 - 97	•
TRX	200 SX	86 - 88	•
TRX	250 Recon	97 - 21	•

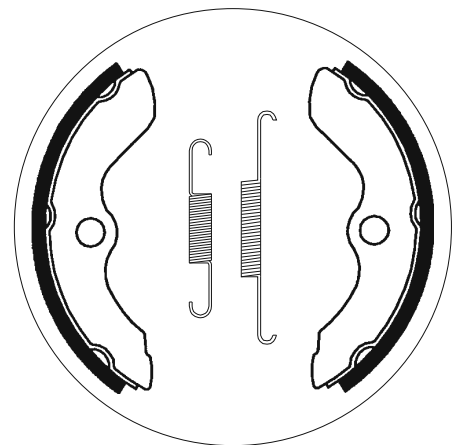

SBS 2085

ø160 x 21



HONDA

TRX	300 4WD	88 - 00	•
TRX	350 Rancher /ES 2x4, 4x4	00 - 09	•
TRX	400 AT	04 - 11	•
TRX	400 FW Fourtrax Foreman	95 - 02	•
TRX	450 Foreman ES, Foreman S	98 - 04	•
TRX	500 Foreman, Rubicon	00 - 09	•
TRX	650 FA Rincon	03 - 05	•
TRX	650 FGA Rincon	04 - 05	•

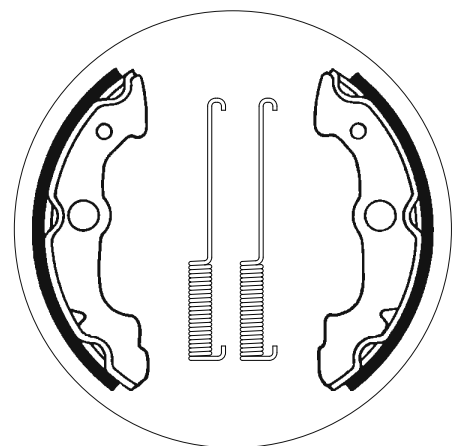

Dimensions in mm / Dimensions en mm  
1" = 25.4 mm , 1 mm = 0.04"

ø100 x 28

SBS 2087

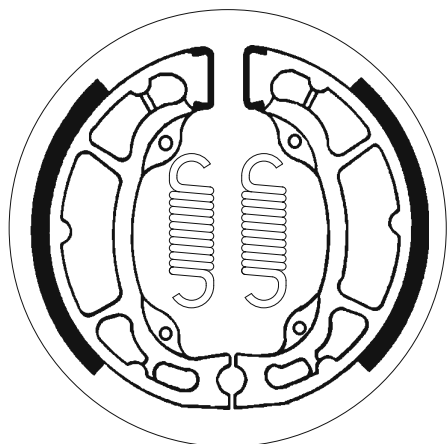

KAWASAKI			
KX	80	79 - 82	•

ø180 x 30

SBS 2088

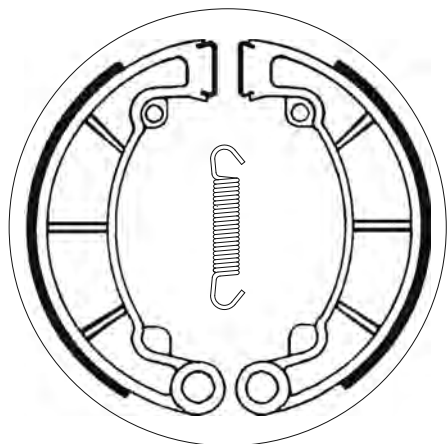

KAWASAKI			
KH	250	76 - 80	•
S2A	350	73 - 73	•
KH	400	76 - 78	•
KZ	400	74 - 77	•

ø200 x 35

SBS 2091

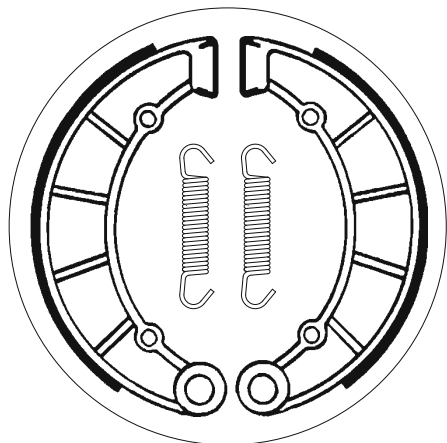

KAWASAKI			
KZ	750 H	72 - 75	•
Z	750 H	72 - 75	•
KZ	900	76 - 77	•
KZ	900 A	76 - 77	•
Z	900 A	76 - 77	•
Z1	900 Z1 A, Z1 B	73 - 75	•

**SBS 2092****ø95 x 20****KAWASAKI**

KX	80	83 - 83	•	

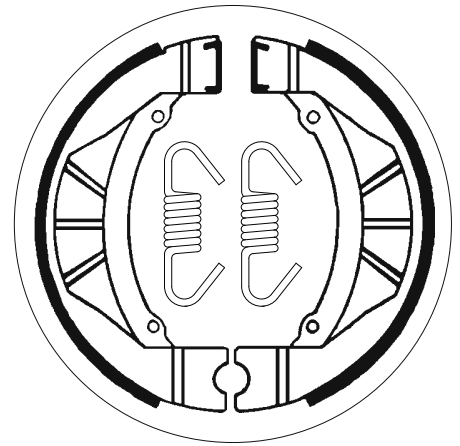
**SBS 2093****ø90 x 20****KAWASAKI**

KX	60	83 - 03	•	•
KX	80	83 - 87	•	
KLX	110	02 - 24	•	

**SUZUKI**

RM	60	03 - 03	•	•
DR-Z	110	02 - 06	•	

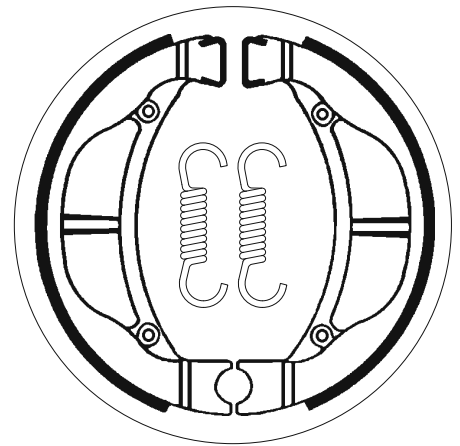
**SBS 2094****ø100 x 25****SUZUKI**

FZ	50	79 - 83	•	•
S	50 K	93 - 93	•	•
TS	50	84 - 02	•	•
TSW	50	91 - 91	•	•
CS	80 CD	83 - 85	•	•
TS	80 X	84 - 87	•	•

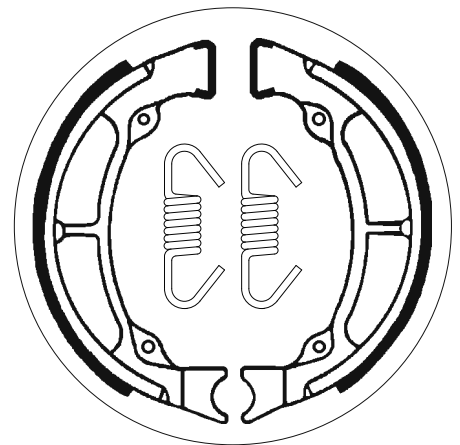
Brake Shoe  
 Drawings, Fitments

ø180 x 28

SBS 2097

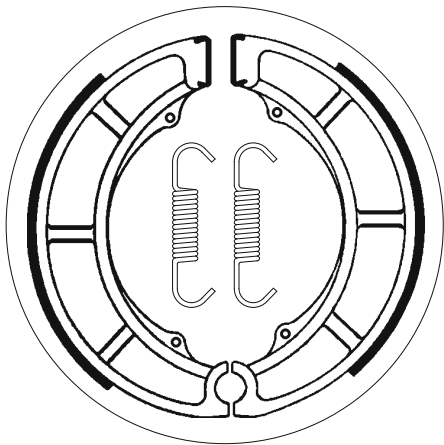

SUZUKI			
GT	250	73 - 78	•
GT	380	73 - 77	•
GT	380 Asco	77 - 77	•
GS	400	77 - 82	•
GSX	400	81 - 83	•
GSX	400 S, Katana	83 - 86	•

ø180 x 40

SBS 2098

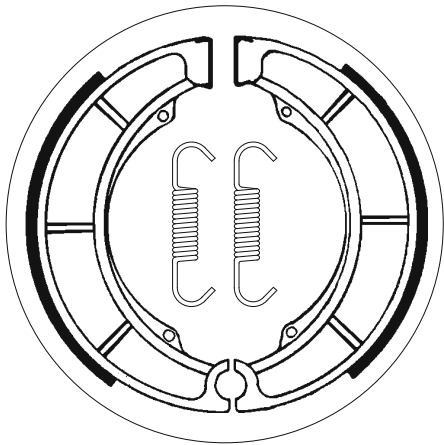

SUZUKI			
RE	5M, A	75 - 77	•
LT	250	85 - 86	•
LT-F	250 4WD V, W Quadrunner	97 - 98	•
LT	300	87 - 89	•
GT	500	73 - 77	•
GT	550	73 - 77	•
GT	750	73 - 77	•

ø180 x 32

SBS 2099

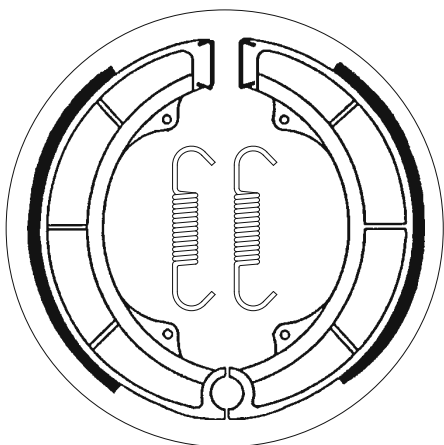

SUZUKI			
GS	550	77 - 77	•
GT	550	78 - 78	•

SBS 2101

ø80 x 20



SUZUKI			
CL	50 D, Suzi, Love	83 - 83	•
FA	50	80 - 91	• •
FS	50 Snip	80 - 81	• •
LT-A	50 Quadmaster	01 - 05	•
LT-Z	50 Quadsport	06 - 20	•
LT	80	87 - 06	•

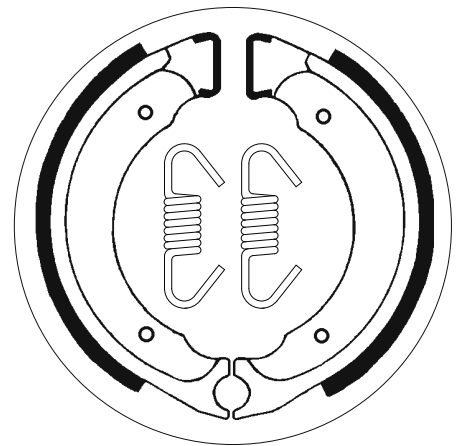

SBS 2102

ø120 x 22



SUZUKI			
RM	125	81 - 87	•
RM	250	81 - 83	•

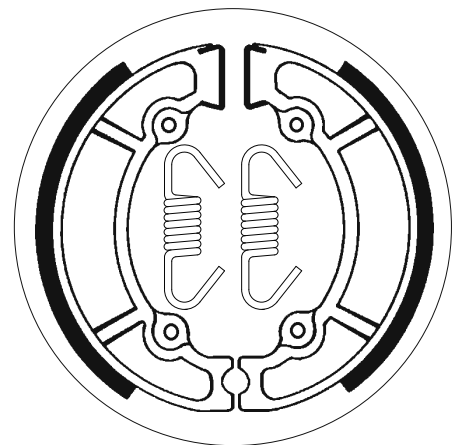

SBS 2103

ø120 x 28



SUZUKI			
	50 Wolf	89 - 94	•
RG	50 GAG	87 - 92	•
RG	50 Gamma	90 - 96	•
S	50 K	93 - 93	•
TS	50	84 - 02	•
TSW	50	91 - 91	•
TV	50 Wolf	89 - 91	•
TS	80 X	84 - 87	•
RM	100	79 - 81	•
RM	125	79 - 80	•
TS	125	85 - 89	•
TS	240 X	85 - 90	•

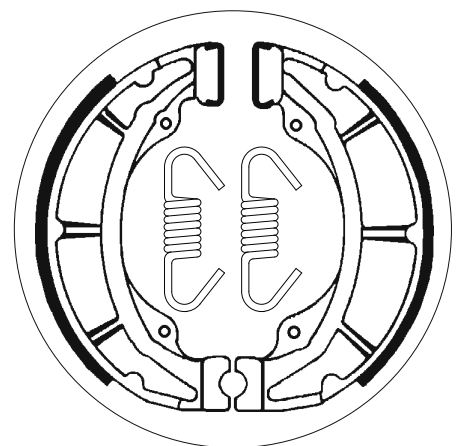

Brake Shoe Drawings, Fitments



ø130 x 22

SBS 2104

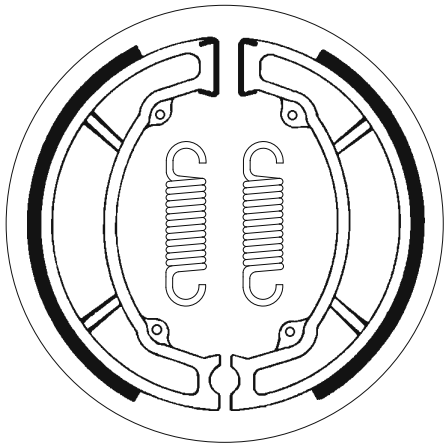

SUZUKI			
LT	80	87 - 06	•
LT-Z	90 Quadsport	07 - 20	•
PE	175	82 - 82	•
RM	250	80 - 80	•
RM	250	84 - 86	•
RM	400	80 - 80	•

ø150 x 22

SBS 2107

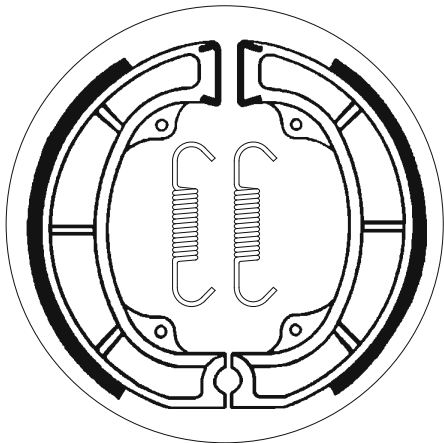

SUZUKI			
ALT	125 D	83 - 83	•
LT	125 D	83 - 83	•
RM	250	81 - 82	•
RM	465	81 - 82	•

ø130 x 22

SBS 2108

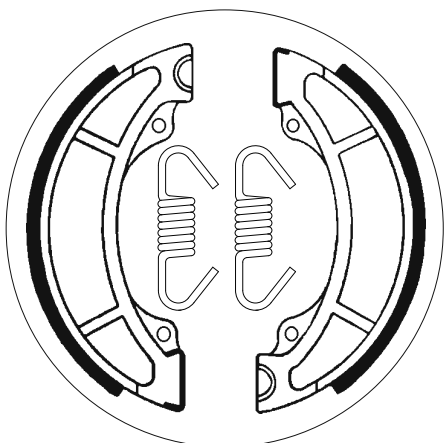

SUZUKI			
RM	125	84 - 84	•
RM	250	83 - 84	•
RM	500	83 - 84	•

**SBS 2110**

ø165 x 28



SUZUKI			
LT	250 4WD	87 - 98	•
LT-F	250	88 - 01	•

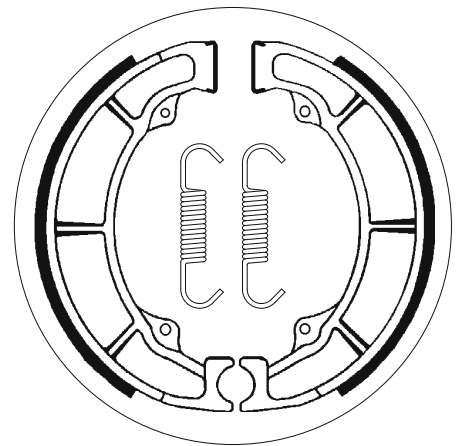

**SBS 2111**

ø160 x 30



SUZUKI			
DR	750 S, Big	88 - 88	•

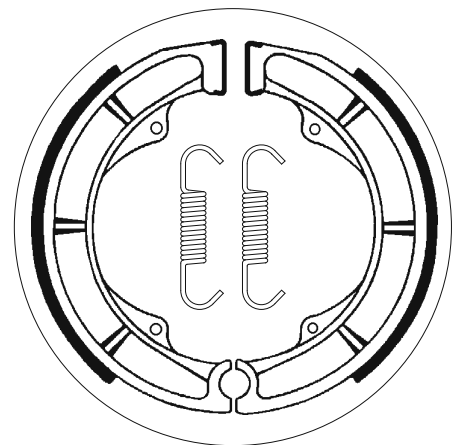

**SBS 2112**

ø80 x 17



MBK			
	50 Champ	91 - 91	• •
YAMAHA			
CA	50 Riva Saliènt	83 - 86	•
CG	50 A, B Riva Jog	90 - 91	•
JOG	50 E	88 - 90	•
MA	50 M, QT 50	80 - 86	• •
MJ	50 J, M Towner	82 - 82	• •
MJ	50 M Towner	81 - 93	• •
MS	50	85 - 86	•
PW	50	80 - 24	• •
QA	50 Pocke	83 - 85	• •
QB	50 Vogel	83 - 85	• •
QT	50 Yamahopper	79 - 87	• •
SA	50 M,		
	ME Passola	80 - 84	•
SH	50 E, F Razz	93 - 95	•
SH	50 Mint	93 - 96	•



YAMAHA			
SH	50 T, EMT, U, MU, W, MW, A, MA, B, D, MD	87 - 93	•

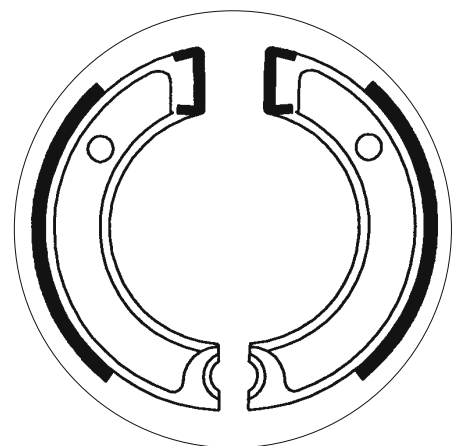

Ø180 x 30

SBS 2113

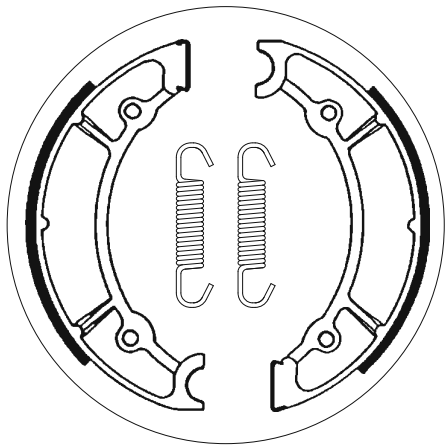

YAMAHA			
RD	200 A, B	74 - 75	•
YDS-7	200	73 - 75	•
XS	250 C	81 - 81	•
XS	400	78 - 81	•

Ø160 x 30

SBS 2114

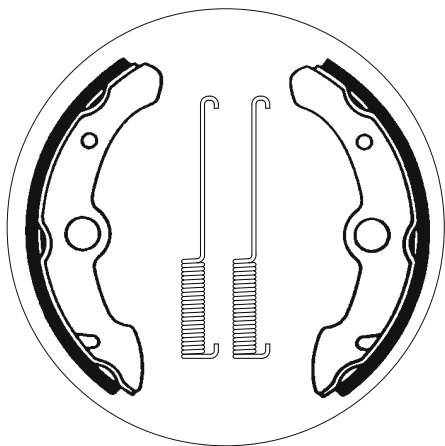

YAMAHA			
YFM	350 FWT, FWU Big Bear	87 - 88	•

Ø130 x 28

SBS 2115

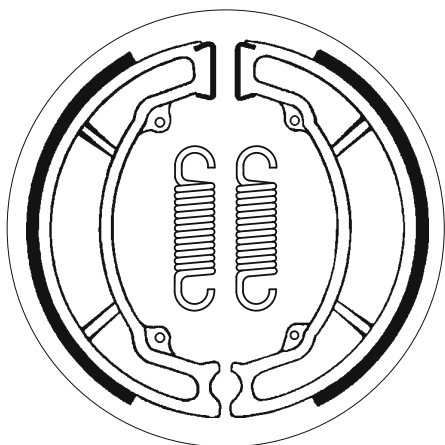

YAMAHA			
BL	125 Beluga	88 - 93	•
XC	125 Beluga, Riva	87 - 92	•
XC	125 E, F Riva	93 - 95	•
XC	180 Cygnus, Riva	83 - 85	•
XC	200 Riva	87 - 91	•

**SBS 2116**

**ø162 x 25**



<b>HUSQVARNA</b>			
	all models	72 - 79	• •
	all models	87 - 88	•
	all models TE,TC,		
	WR,CR,AE	89 - 89	•
CR	125	83 - 84	•
CR/RL	125	81 - 82	•
WR	125	80 - 80	•
XC	125	85 - 85	•
CR	250	81 - 84	•
WR/OR	250	80 - 80	•
WR/OR	390	80 - 80	•
WRX	400	85 - 85	•
	430 Enduro	85 - 88	•
CR	430	82 - 82	•
WR	430	87 - 89	•
CR	500	83 - 84	•
CX/CR	500	84 - 85	•

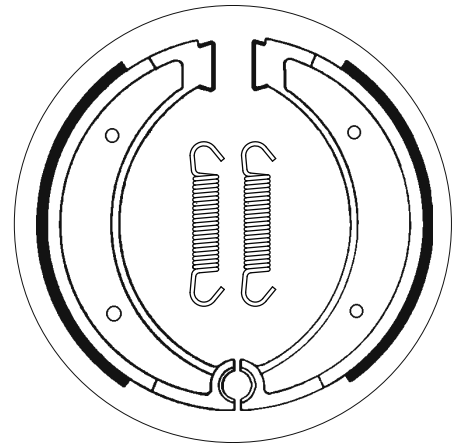

**SBS 2117**

**ø160 x 30**



<b>HUSQVARNA</b>			
	all rear drum		
	models	86 - 86	•
CR	125	85 - 90	•
CR/RL	125	81 - 82	•
WR	125	80 - 80	•
WR	125	85 - 90	•
WR/XC	125	82 - 82	•
WR/XC	125	83 - 84	•
CR	250	81 - 82	•
CR	250	85 - 87	•
WR/OR	250	80 - 80	•
WR/XC	250	81 - 82	•
WR/XC	250	83 - 84	•
WR/OR	390	80 - 80	•
WR/XC	390	82 - 82	•
	400 Enduro	85 - 88	•
WR	400	87 - 88	•
	430 Auto	87 - 87	•



<b>HUSQVARNA</b>			
CR	430	82 - 82	•
CR	430	87 - 89	•
CR/WR/CS	430	81 - 81	•
XC	430	87 - 88	•
CR	500	86 - 87	•
TC	500	86 - 86	•
WR/XC/AE	500	83 - 84	•
XC	500	87 - 88	•
	504	83 - 83	•
	510	87 - 89	•
TE	510	86 - 87	•

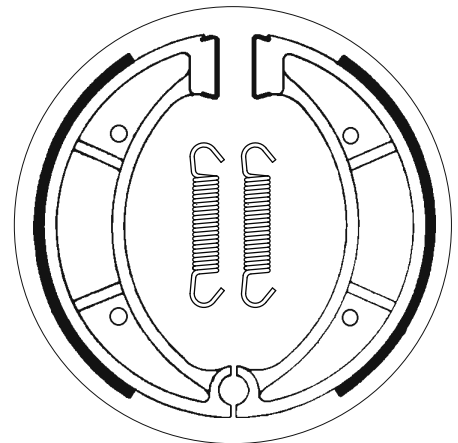

**SBS 2118**

**ø160 x 25**



<b>HUSQVARNA</b>			
CR	125	83 - 84	•
WR/XC	125	83 - 84	•
CR	250	83 - 84	•
WR/XC	250	83 - 84	•
WRX	400	85 - 85	•
CR	500	83 - 84	•
WR/XC/AE	500	83 - 84	•

<b>KTM</b>			
	250 Cross	83 - 83	•
	500 Cross	82 - 82	•

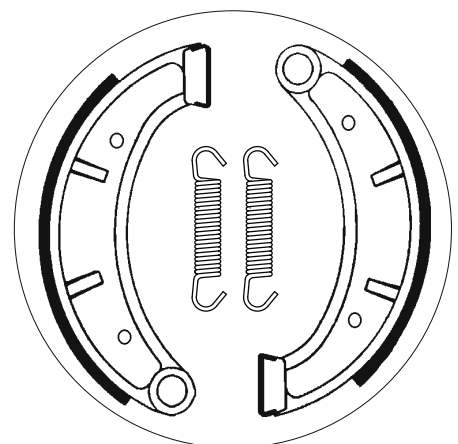

Dimensions in mm / Dimensions en mm  
1" = 25.4 mm , 1 mm = 0.04"

ø130 x 30

SBS 2120

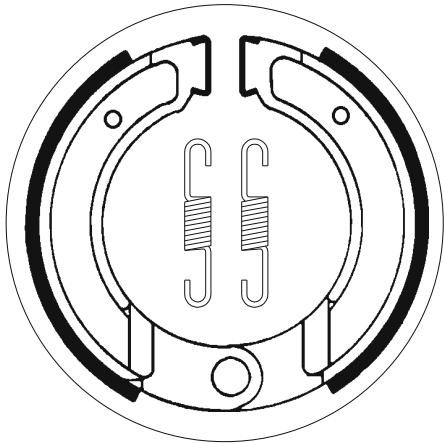

<b>KTM</b>			
	40 Comet	91 - 95	• •
	125	83 - 83	• •
GS	125	83 - 83	•
LL	125	83 - 83	•
	175	72 - 78	• •
	175	79 - 82	•
	250 Cross	80 - 81	• •

ø181 x 25

SBS 2121

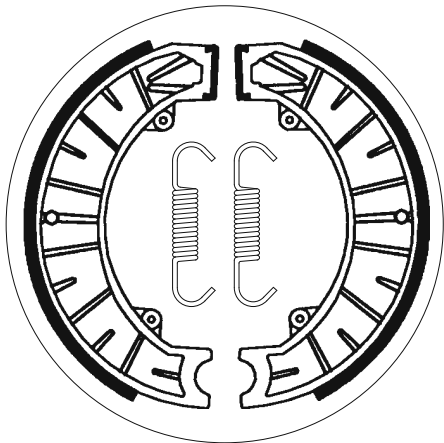

<b>KTM</b>			
	175	79 - 82	•
	250 Cross	82 - 82	• •
	250 Cross	83 - 83	•
	350 GS	83 - 85	•
	390 GS	83 - 83	•
MC	495 Leleu	82 - 83	•
MX	495 Leleu	82 - 83	•
	500 Cross	82 - 82	•
GS	500 500 K4 Enduro	83 - 83	•

ø130 x 22

SBS 2122

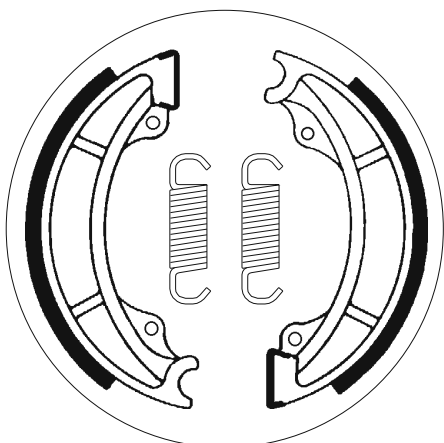

<b>ATK</b>			
ATK	560	84 - 85	•
<b>KTM</b>			
MX	80	86 - 90	•
GS	125	83 - 83	•
GS	125	84 - 85	• •
LL	125	83 - 83	• •
MX	125	84 - 84	• •
MX	125	85 - 85	• •
XC	125	85 - 85	• •
	250 Baja	86 - 89	• •
	250 Country,Baja	85 - 85	• •
GS	250	83 - 85	• •
MX	250	84 - 84	• •
MX	250	85 - 85	• •
GS	300	85 - 85	• •
MX	300	85 - 89	• •
XC	300 (Drum vers.)	85 - 85	• •

<b>KTM</b>			
XC	300	85 - 85	•
	350 Country Cross	85 - 85	•
	350 GS (Drum vers.)	83 - 85	• •
	390 GS (Drum vers.)	83 - 83	• •
GS	420	84 - 87	• •
MX	495	84 - 84	• •
LC	500	85 - 85	•
MX	500	83 - 84	• •
MX	500	85 - 85	• •
GS	600	84 - 84	• •
GS	600	85 - 85	• •

Dimensions in mm / Dimensions en mm  
1" = 25.4 mm , 1 mm = 0.04"

## SBS 2139

ø200 x 30



## BMW

R45	450	78 - 80	•
R60	600 Series	74 - 80	•
R60/7	600	76 - 77	•
R65	650	78 - 80	•
R70	700 Series	74 - 80	•
R75/6	750	74 - 76	•
R75/7	750	76 - 77	•
R80	800	81 - 81	•
R80/7	800	77 - 78	•
R90	900 S	73 - 76	•
R90	900 Series	74 - 80	•
R90/6	900	73 - 76	•
R100	1000	79 - 81	•
R100	1000 S	76 - 77	•
R100/7	1000	78 - 80	•

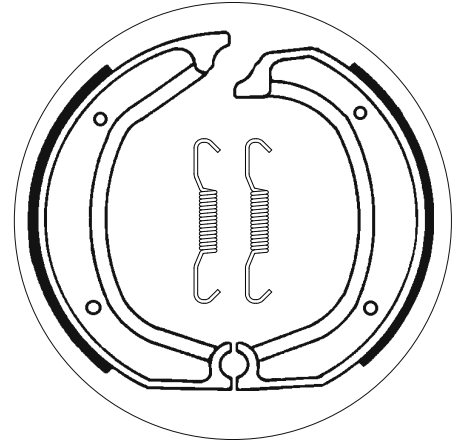

## SBS 2140

ø200 x 25



## BMW

R45	450	80 - 85	•
R65	650	80 - 80	•
R65	650 GS	87 - 92	•
K75	750 C	85 - 88	•
R75	750	86 - 86	•
	800 Touring	87 - 87	•
R80	800	77 - 88	•
R80	800 G/S P.-D.	86 - 86	•
R80	800 GS	81 - 87	•
R80	800 GS	91 - 92	•
R80	800 GS Mystic	91 - 95	•
R80	800 RT	83 - 83	•
R80	800 RT	84 - 85	•
R100	1000 all models	81 - 84	•
R100	1000 GS	87 - 94	•
R100	1000 GS Mystic	91 - 94	•

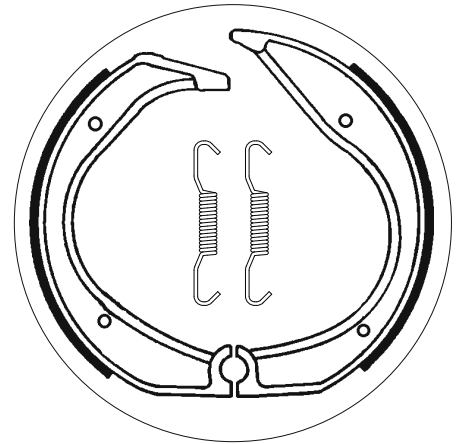

## SBS 2141

ø220 x 25



## BMW

R65	650 LS	82 - 85	•

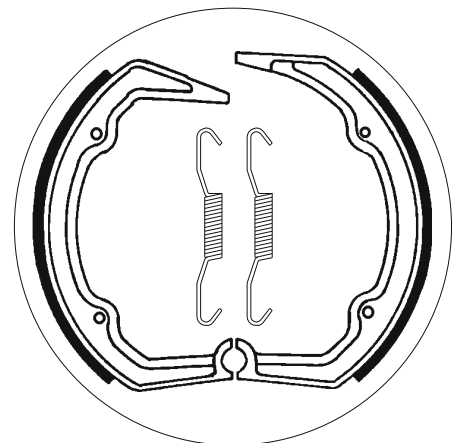

Dimensions in mm / Dimensions en mm  
1" = 25.4 mm, 1 mm = 0.04"

∅200 x 27

SBS 2143

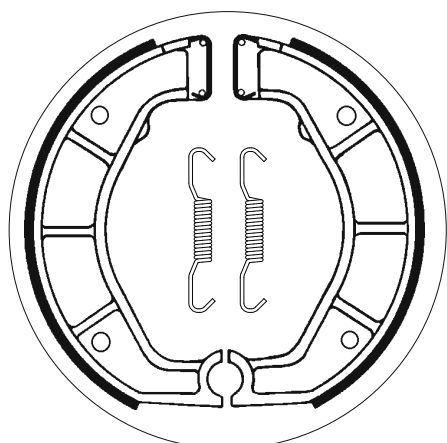

BMW			
R80	800 R	93 - 94	•
R100	1000 R	92 - 95	•
R100	1000 RT	91 - 95	•

∅150 x 24

SBS 2146

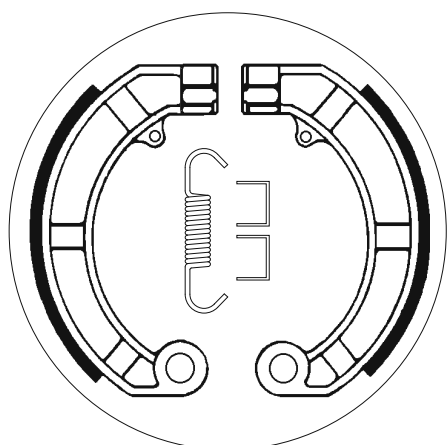

PIAGGIO VESPA			
	50 HP	92 - 97	•
	50 V FL2	90 - 90	•
PK	50	83 - 98	•
PK	50 Special	83 - 98	•
PK	50 XL	86 - 98	•
PK	50 XL 2	86 - 98	•
PK	125	83 - 89	•
PK	125 Automatica	84 - 89	•
PK	125 Special	83 - 89	•
PK	125 XL	86 - 89	•
PX	125	78 - 89	•
PX	125 Arcobalenco	83 - 89	•
	150 Sprint Veloce	75 - 80	•
PX	150	78 - 82	•
PX	150 Arcobalenco	83 - 88	•
GS	160	75 - 80	•
SS	180	75 - 80	•
	200 Rally	75 - 80	•



PIAGGIO VESPA			
PE	200	83 - 88	•
PX	200 Arcobalenco	83 - 85	•
PX	200 E	78 - 85	•

∅160 x 30

SBS 2171

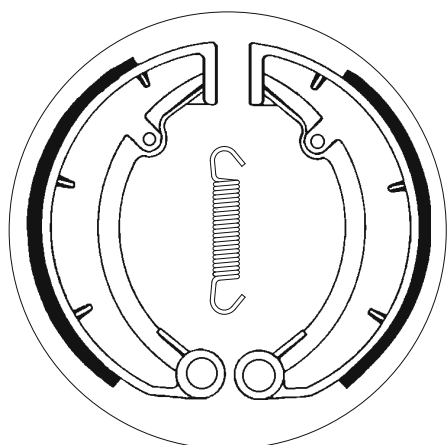

MZ			
TS	125	73 - 85	•
TS	150	73 - 85	•
ETZ	250	82 - 84	•
ETZ	250	85 - 92	•
TS	250	73 - 81	•

SBS 2172

ø150 x 30



MZ			
ETZ	125	82 - 84	•
ETZ	125	85 - 92	• •
TS	125	73 - 85	•
ETZ	150	82 - 84	•
ETZ	150	85 - 92	• •
TS	150	73 - 85	•

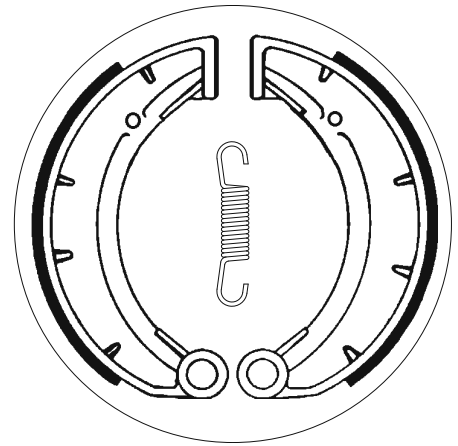

SBS 2177

ø170 x 27



YAMAHA			
YFU1TW	250 Pro Hauler	89 - 89	•
YFU1W	250 Pro Hauler	89 - 90	•
YFP	350 U Terrapro	88 - 88	•

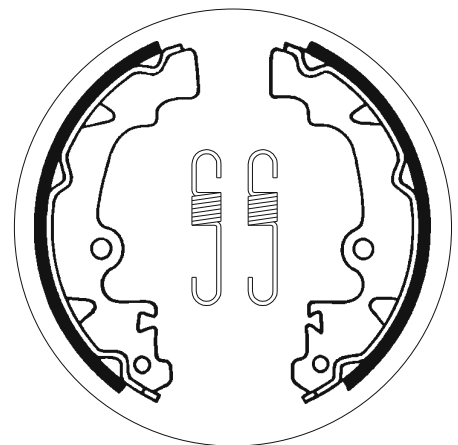

SBS 2178

ø160 x 25



YAMAHA			
YFM	350 Big Bear Special Edition	99 - 99	•
YFM	350 FWH, FWJ, FWK Big Bear	96 - 98	•
YFM	350 FWW, FWA-G Big Bear	89 - 95	•
YFM	350 UH, UJ, UK	96 - 98	•
YFM	400 Kodiak	93 - 99	•

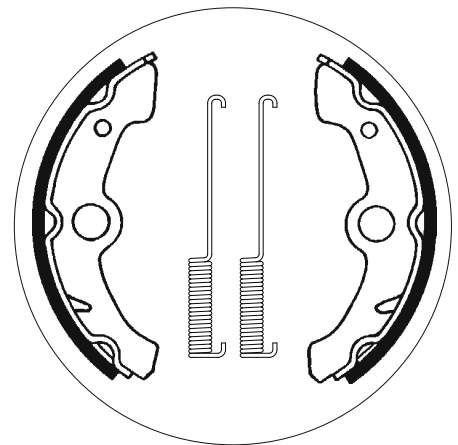



ø120 x 25

SBS 2181

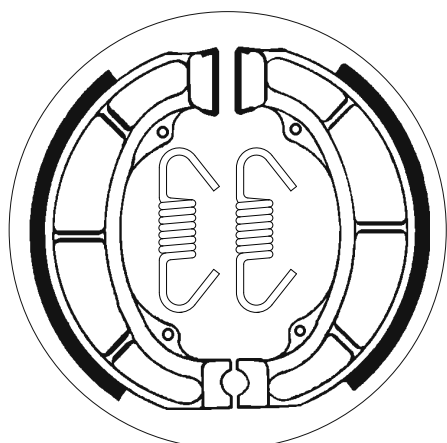

<b>ATALA</b>			
	50 Hacker	95 - 00	•
<b>CAGIVA</b>			
	50 Mantis	99 - 99	•
<b>DERBI</b>			
	50 Atlantis	99 - 08	•
	50 Easy	96 - 98	•
	50 Hunter	97 - 99	•
	50 Manhattan	99 - 99	•
	50 Vamos FL	95 - 99	•
	50 Vamos L	95 - 95	•
ST	50 Paddock	96 - 99	•
<b>HUSQVARNA</b>			
WRS	50	98 - 98	•
<b>PGO</b>			
	150 T-Rex	01 - 06	•
<b>SUZUKI</b>			
	50 Lido Scooter	89 - 94	• •
AH	50 Adress	92 - 95	•



<b>SUZUKI</b>			
AJ	50 Sepia	92 - 96	•
AY	50 , Katana	96 - 08	•
CP	50 CHF	85 - 85	• •
UF	50 Estilete	00 - 02	•
UX	50 W Zillion	99 - 02	•
ZZ	50 Scooter	92 - 92	•
LIDO	75 Style	84 - 94	•
AH	80 Adress, V, Tune	88 - 91	•
AH	80 Scooter	92 - 94	•
CP	80	85 - 93	• •
AH	100 V Adress	91 - 94	•
	125 Vecstar	94 - 97	•
AN	125	06 - 08	•
AN	125 R	94 - 05	•
LIDO	125 Vario Scooter	90 - 93	•
AN	150	98 - 01	•
LT	160	89 - 92	•
LT-F	160	91 - 04	•
	250 Vecstar	94 - 94	•
<b>VELOCIFERO</b>			
	50 Velocifero	94 - 94	•

ø95 x 20

SBS 2182

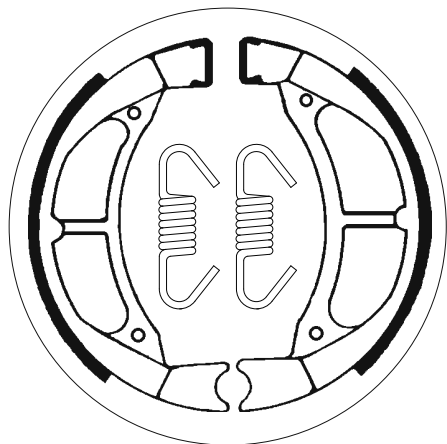

<b>SUZUKI</b>			
RM	80	82 - 89	•
<b>YAMAHA</b>			
JOG-Z	50	88 - 89	•
YZ	50	80 - 83	• •
YZ	60	85 - 85	• •
BW	80	86 - 90	• •
CJ	80	86 - 88	• •
PW	80	83 - 85	•
PW	80	91 - 08	•
TY	80	77 - 84	•
YZ	80	74 - 79	•
YZ	80	80 - 85	• •
YZ	80	86 - 92	•
TT-R	90	00 - 10	•



<b>YAMAHA</b>			
TT-R	110	08 - 24	•

ø130 x 28

SBS 2183

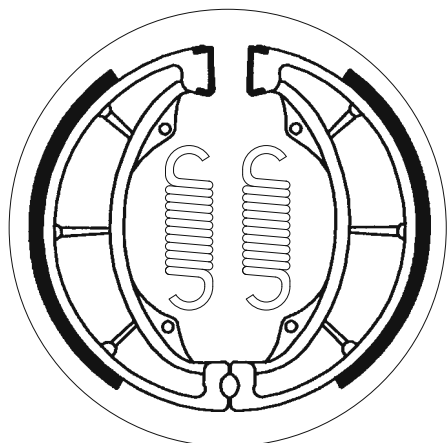

<b>KAWASAKI</b>			
KLF	110 Mojave	87 - 88	•
KLT	110	84 - 86	•
AR	125	82 - 94	•
BN	125 Eliminator	98 - 99	•
BN	125 Eliminator A3	00 - 07	•
KE	125	76 - 85	•
KX	125	74 - 82	•
KLT	160	85 - 85	•
KDX	175	80 - 82	•
KE	175	76 - 78	•
KLT	185	86 - 87	•
KDX	250	83 - 84	•
KLX	250	79 - 80	•
KT	250 all models	75 - 80	•
KX	250	82 - 85	•
Z	250	81 - 83	•



<b>KAWASAKI</b>			
Z	250 Eliminator	88 - 88	•
KX	500	83 - 85	•
KL	600	84 - 86	•
KLR	600	84 - 86	•
KLR	600 E	85 - 94	•
<b>SUZUKI</b>			
TU	125 XT	99 - 99	•
NZ	250	86 - 91	•

SBS 2184

ø170 x 26



**PIAGGIO VESPA**

125 Cosa	89 - 91	•
125 Cosa 2	92 - 97	•
150 Cosa	89 - 91	•
200 Cosa	89 - 91	•
200 Cosa 2	92 - 97	•

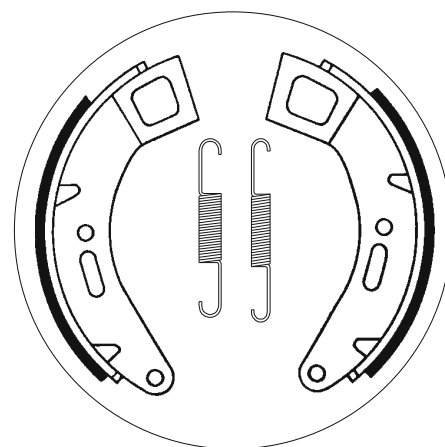

SBS 2185

ø170 x 26



**PIAGGIO VESPA**

125 Cosa	89 - 91	•
125 Cosa 2	92 - 97	•
150 Cosa	89 - 91	•
200 Cosa	89 - 91	•
200 Cosa 2	92 - 97	•

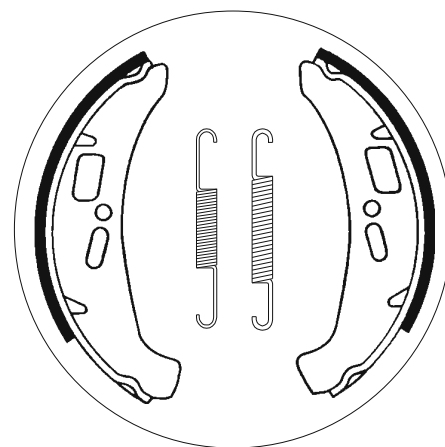

SBS 2187

ø100 x 20



**GILERA**

50 Easy Moving	96 - 11	•
50 Storm	94 - 98	•
50 Typhoon	93 - 95	•
NRG 50	94 - 95	•
80 Typhoon	95 - 99	•

**PIAGGIO VESPA**

50 Quartz	92 - 96	•
50 Sfera	91 - 99	•
50 Storm	94 - 97	•
50 Typhoon	94 - 95	•
50 Zip	92 - 93	•
50 Zip & Zip	94 - 97	•
NRG.1 50	94 - 95	•
TPH 50	93 - 95	•
80 Sfera	94 - 99	•



**PUCH**

50 Storm (Austria)	78 - 83	•
50 Typhoon (Austria)	95 - 95	•

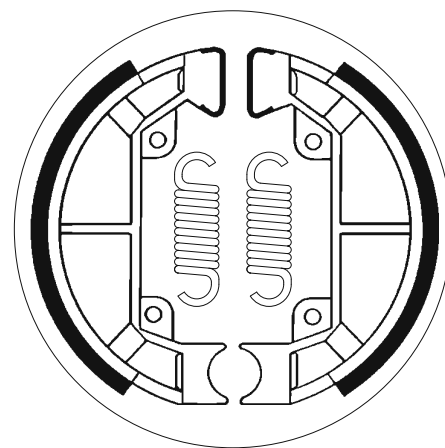

Brake Shoe Drawings, Fitments

Ø110 x 23

SBS 2188

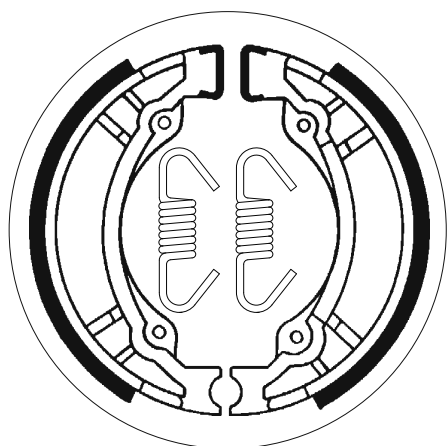

PGO		
50 Big Max	94 - 02	•
50 Big Max Sport	96 - 04	•
50 Comet	91 - 97	•
50 Galaxy	91 - 97	•
PS		
50	93 - 93	•
90 Galaxy	92 - 94	•
100 Big Max	96 - 99	•

SUZUKI		
TR 50 Street Magic	97 - 00	•
UG 110 Hokuto	00 - 02	•

SYM		
125 Husky	96 - 98	•
125 Super Duke	95 - 01	•
150 Husky	99 - 02	•



TGB		
50 202T	99 - 02	•

Ø130 x 25

SBS 2189

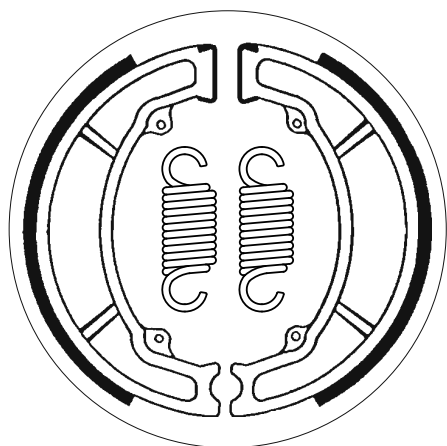

HONDA		
CN 250 Helix	86 - 87	•
CN 250 Scooter	88 - 92	•
CN 250 Spazio	88 - 92	•

VELOCIFERO		
50 Velocifero	94 - 94	•

Ø200 x 25

SBS 2190

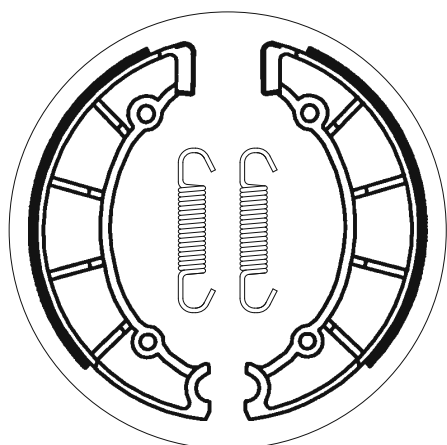

YAMAHA		
SR 500	92 - 98	•



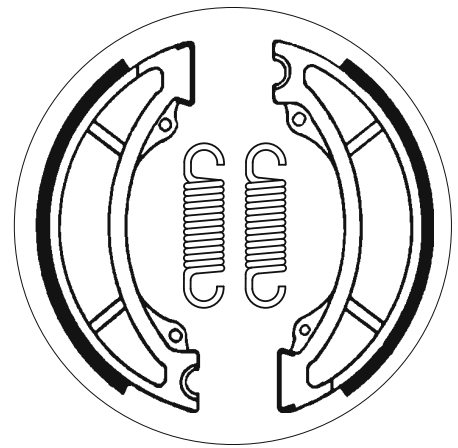

YAMAHA		
SR	250	90 - 93 •

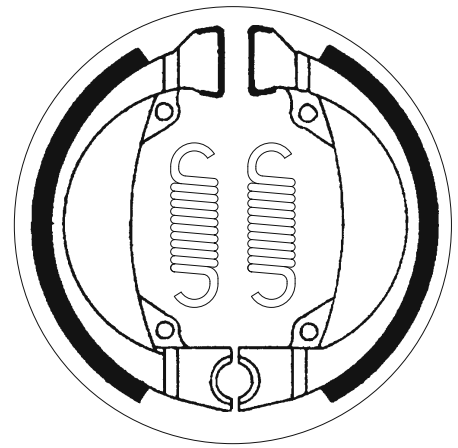

HONDA		
PXR	50 all models	85 - 02 •

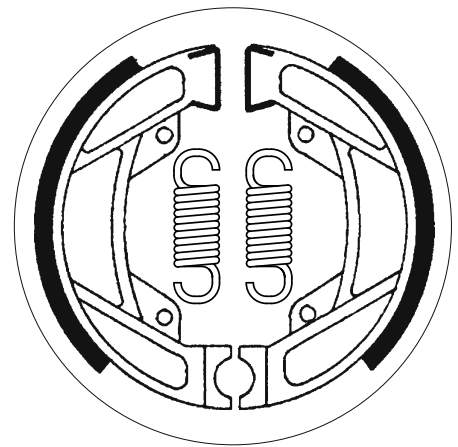

HONDA		
PXR	50 all models	85 - 02 •
MBK		
50 Evasion straight wheels	01 - 01 •	•
50 Hardrock straight wheels	01 - 01 •	•
50 Magnum straight wheels	01 - 01 •	•
50 Passion straight wheels	01 - 01 •	•



ø110 x 25

SBS 2195

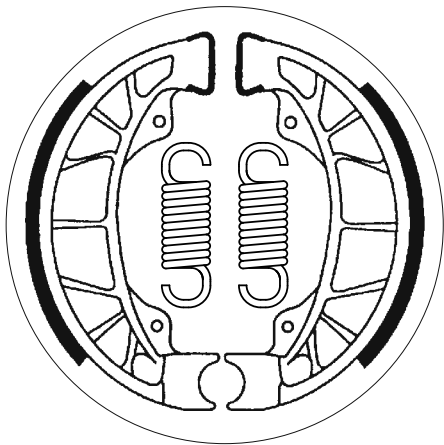

GILERA		
50 Eaglet	96 - 96	•
50 Runner	97 - 05	•
125 Typhoon	96 - 00	•

PIAGGIO VESPA		
25 Zip II Cat DT	01 - 01	•
50 Zip Disco	96 - 99	•
50 Zip Fast Rider	96 - 97	•
50 Zip II	01 - 15	•
50 Zip II Cat DT	01 - 12	•
ET2 50	97 - 06	•
ET4 50	00 - 05	•
LX 50 2T/4T	05 - 12	•
125 Hexagon	94 - 95	•
125 Sfera	95 - 01	•
125 Skipper	93 - 95	•
125 Zip II 4T	00 - 08	•
ET4 125	96 - 10	•



PIAGGIO VESPA		
LX4 125 Hexagon	99 - 07	•
TPH 125	96 - 03	•
150 Hexagon	94 - 97	•

ø105 x 20

SBS 2196

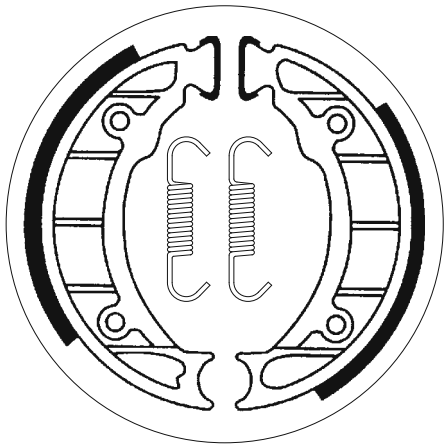

PIAGGIO VESPA		
50 Free (Disc Brake version)	97 - 99	•
50 Zip	92 - 93	•

ø180 x 35

SBS 2197

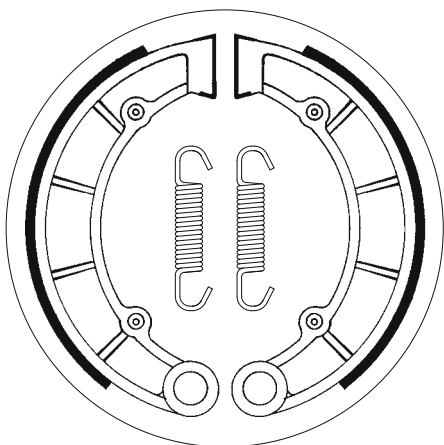

KAWASAKI		
KLF 300 Bayou Left/Rear	89 - 05	•
KLF 400 Bayou Left	93 - 99	•
KVF 400 Prairie	97 - 98	•

**SBS 2198**

ø160 x 30

**HONDA**

FES	125 Pantheon	98 - 02	•
FES	150 Pantheon	99 - 02	•
FES	250 Foresight	98 - 99	•

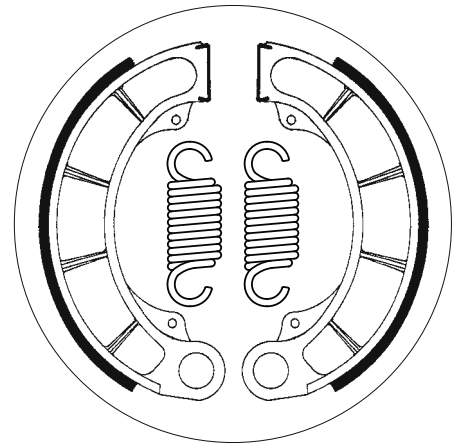
**SBS 2199**

ø130 x 28

**MBK**

YP	125 Skyliner	99 - 00	•

**YAMAHA**

XN	125 Teos	01 - 04	•
XVS	125 Drag Star	00 - 06	•
YBR	125	08 - 16	•
YP	125 R Majesty	99 - 00	•
	150 Teos	02 - 05	•
YP	180 R Majesty	03 - 03	•
XVS	250 Drag Star	01 - 04	•

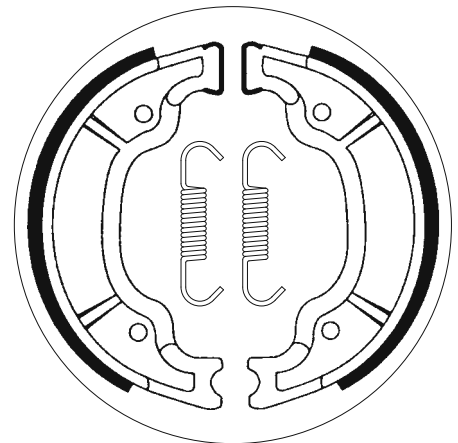
**SBS 2200**

ø100 x 20

**GILERA**

	50 Typhoon	96 - 01	•

**PIAGGIO VESPA**

	50 Zip Fast Rider	93 - 95	•
NRG	50	96 - 00	•
NRG	50 mc2	97 - 99	•
NTT	50	96 - 96	•
RST	50 Sfera	95 - 99	•
TPH	50	96 - 97	•

**PUCH**

	50 Typhoon (Austria)	96 - 96	•

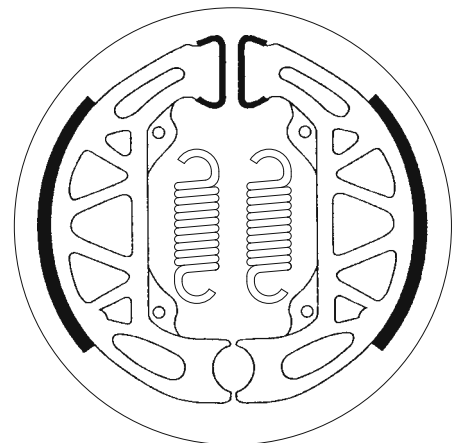

Dimensions in mm / Dimensions en mm  
1" = 25.4 mm , 1 mm = 0.04"

ø120 x 25

SBS 2201

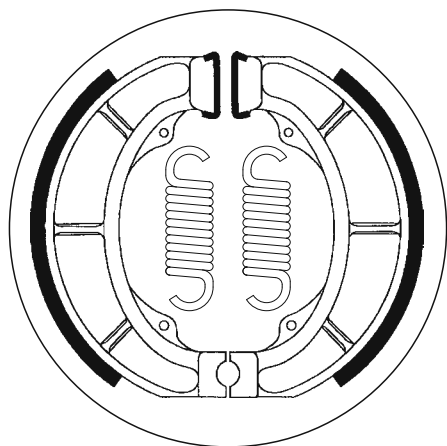

APRILIA		
50 Compay	09 - 13	•
50 Habana/Custom	99 - 02	•
50 Mojito Retro	99 - 03	•
50 Mojito, Mojito Custom	99 - 03	•

ø130 x 28

SBS 2202

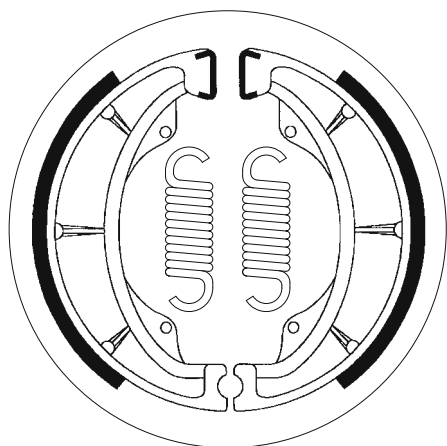

SUZUKI		
UC 125 Epicuro	99 - 02	•
UC 150 Epicuro	99 - 02	•

ø130 x 25

SBS 2203

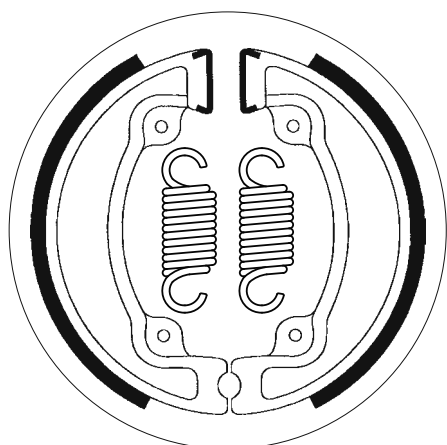

KYMCO		
50 Agility (4T) R16	06 - 15	•
50 People	99 - 06	•
50 Super-8	08 - 16	•
125 Movie	99 - 08	•
125 People	01 - 09	•
150 People	01 - 06	•

**SBS 2205**

**ø140 x 25**



<b>APRILIA</b>		
125 Habana/Custom	00 - 02	•
125 Mojito, Mojito Custom	02 - 12	•
SR 125	99 - 03	•
SR 150	00 - 03	•
<b>DERBI</b>		
125 Boulevard	03 - 07	•
150 Boulevard	03 - 09	•
<b>GILERA</b>		
FX 125 Runner	97 - 99	•
FX 150 Runner	97 - 01	•
FX 200 Runner	97 - 98	•
<b>PIAGGIO VESPA</b>		
50 Fly	05 - 17	•
50 Liberty	97 - 14	•



<b>PIAGGIO VESPA</b>		
50 Liberty 4T	00 - 12	•
100 Fly	07 - 15	•
100 Zip	07 - 10	•
125 Fly	05 - 13	•
LE 125 Liberty	99 - 03	•
LX 125 Hexagon	99 - 00	•
LX 125 Skipper, ST	99 - 04	•
150 Fly	06 - 07	•
150 Liberty	99 - 03	•
LXT 180 Hexagon	99 - 00	•



**SBS 2206**

**ø105 x 25**



<b>DERBI</b>		
50 Aventura	96 - 96	•
50 Vamos R (A.J.P. cal.)	95 - 95	•
50 Vamos R (Brembo cal.)	95 - 95	•
50 Variant Sport-R	01 - 13	•

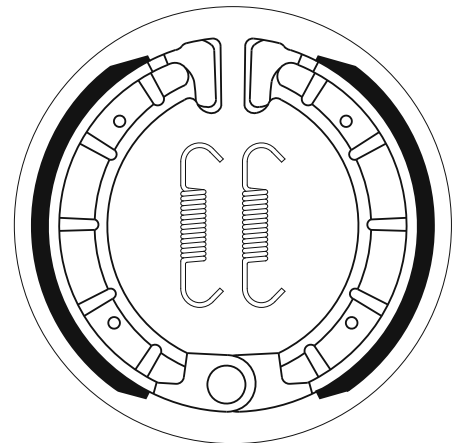

**SBS 2207**

**ø160 x 30**



<b>HONDA</b>		
TRX 350 Rancher /ES 2x4, 4x4	00 - 09	•
TRX 400 AT	04 - 11	•
TRX 400 FW Fourtrax Foreman	95 - 02	•
TRX 450 Foreman ES, Foreman S	98 - 04	•

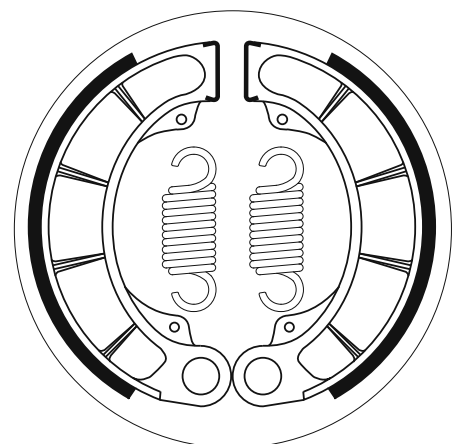

Dimensions in mm / Dimensions en mm  
1" = 25.4 mm , 1 mm = 0.04"



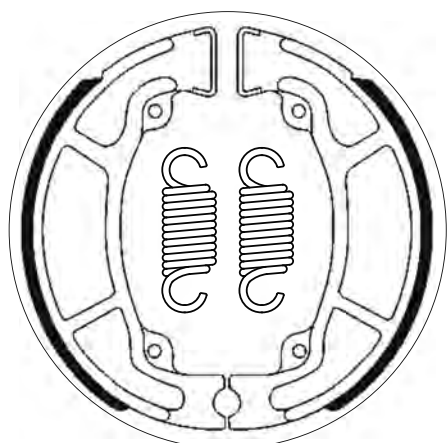

<b>HONDA</b>			
NES	125 @	01 - 06	•
PCX	125	09 - 20	•
PCX	125 (Nissin cal.)	18 - 20	•
PS	125 i	07 - 13	•
SES	125 Dylan	02 - 07	•
SH	125	02 - 08	•
NES	150 @	01 - 06	•
PCX	150	12 - 20	•
PS	150 i	07 - 11	•
SES	150 Dylan	02 - 06	•
SH	150	02 - 08	•

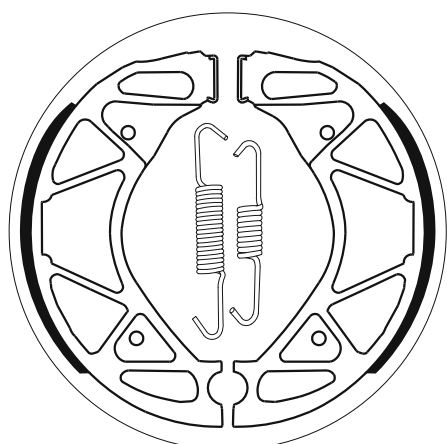

<b>YAMAHA</b>			
	125 Xenter	12 - 18	•
BWs	125	10 - 11	•
NXC	125 Cygnus	10 - 11	•
NXC	125 Cygnus X	05 - 09	•
YW	125 Z	10 - 11	•
	150 Xenter	12 - 18	•

**ALMOST ANY BIKE**  
BRAKE PADS, CLUTCH KITS AND BRAKE DISCS

Find the right part with  
the **PRODUCT SELECTOR**  
at **SBSBRAKES.COM**

**sbs**<sup>®</sup>

GO AHEAD

HI-TECH BRAKE SOLUTIONS  
MADE IN EUROPE



Find the right brake pads, discs or clutches for your bike

Select the fields in any order

Brand\*  CC\*  Model\*  Year\*

SHOW MATCHES >

NEW SEARCH



@sbsbrakes | sbsbrakes.com | #GoAhead

# CROSSLIST

## OE - SBS

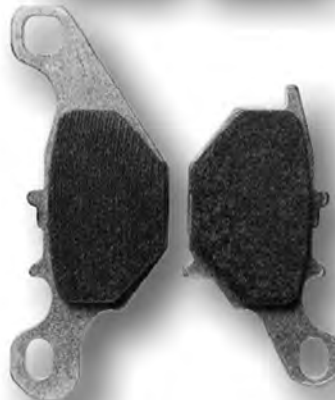
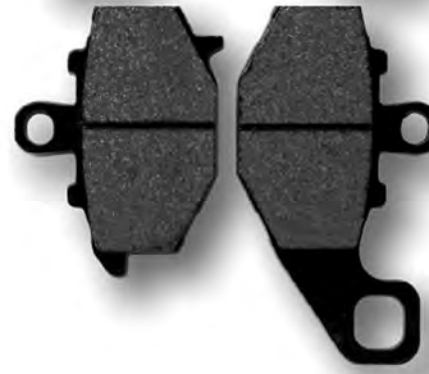
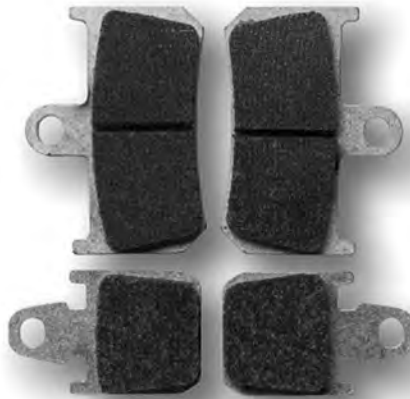
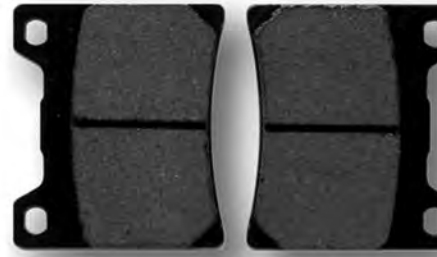
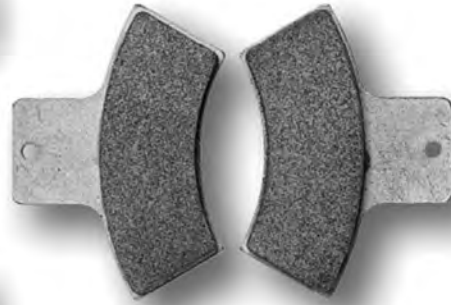

OE No.	SBS No.	OE No.	SBS No.	OE No.	SBS No.	OE No.	SBS No.
0/000-930-0090	203	03613-9666	519	06435-KPC-641	225	06435-MOZ-J01	881
0/000-930-0090	585	0402-096	758	06435-KPC-641	784	06435-MR7-P00	623
0/000-930-7001	167	0402-494	758	06435-KPC-643	225	06435-MS2-P00	181
0/000-930-7001	773	0402-882	758	06435-KPC-643	784	06435-MS2-P00	654
000016546300	706	0452883	135	06435-KPE-016	158	06435-MS9-405	181
0000-365-46000	176	0452883	546	06435-KPE-016	753	06435-MS9-405	654
0000-365-46000	674	0453036	101	06435-KPP-901	225	06435-MT3-405	181
0000-640-7210	180	0453036	544	06435-KPP-901	784	06435-MT3-405	654
0000-640-7210	797	0453200	135	06435-KPP-902	225	06435-MT8-405	160
00009300060	105	0453200	546	06435-KPP-902	784	06435-MT8-405	542
00009300060	559	0453201	135	06435-KRN-711	220	06435-MY9-405	161
00009300065	148	0453201	546	06435-KRN-711	777	06435-MY9-405	614
00009300065	652	0454293	101	06435-KRN-712	220	06435-MZO-006	181
00009300080	168	0454293	544	06435-KRN-712	777	06435-MZO-006	654
00009300080	774	0454440	905	06435-KSV-J01	193	06451-HL3-A00	982
00009308000	157	0454444	906	06435-KSV-J01	832	06451-HL4-A01	981
00009308000	730	0454664	905	06435-KSV-J02	193	06451-HL6-A01	981
00025001198	135	047-00-2000036	566	06435-KSV-J02	832	06451-HPO-A01	829
00025001198	546	04700-2000037	138	06435-KT7-405	161	06451-KZZ-901	228
000276-546100	138	04700-2000037	519	06435-KT7-405	614	06451-KZZ-901	859
000276-546100	519	0502-019	758	06435-KV3-405	161	06452-HL4-A01	981
000306546260	176	0502-604	822	06435-KV3-405	162	06452-HL6-A01	981
000306546260	674	0502-875	822	06435-KV3-405	614	06452-HPO-A01	829
000306546300	641	06 1894	505	06435-KV3-405	657	06455-371-405	517
000306546310	601	06 6005	505	06435-KW6-841	119	06455-425-405	526
000316546650	138	06 6186	505	06435-KW6-841	688	06455-443-405	127
000316546650	519	0624	151	06435-KYJ-901	881	06455-443-405	572
0009307001	105	0624	671	06435-KZ4-J41	220	06455-6CK-006	144
0009307001	559	0631	790	06435-KZ4-J41	777	06455-6CK-006	604
00157056	810	06345-MGZ-J01	161	06435-KZZ-901	915	06455-GAV-405	108
00-1865-4660	506	06345-MGZ-J01	614	06435-MAJ-G41	736	06455-GAV-405	588
00276546100	138	06431-GW2-405	121	06435-MAJ-G41	685	06455-GBF-J01	592
00276546100	519	06431-GW2-405	690	06435-MAT-006	736	06455-GBF-J01	100
00-2865-4601	506	06431-HL6-A01	975	06435-MAT-006	685	06455-GBF-J01	536
00306546250	151	06431-MA3-405	228	06435-MAZ-006	715	06455-GBM-750	123
00306546250	671	06431-MA3-405	859	06435-MBL-D01	736	06455-GBM-750	697
00736071800	895	06435-761-405	517	06435-MCC-006	736	06455-GBY-910	123
00D01210221	105	06435-GCM-900	129	06435-MCE-006	715	06455-GBY-910	697
00D01210221	559	06435-GCM-900	710	06435-MCH-006	736	06455-GBZ-701	100
00G01202221	167	06435-GCM-902	129	06435-MCS-G01	736	06455-GBZ-701	536
00G01202221	773	06435-GCM-902	710	06435-MCS-G03	736	06455-GCC-B52	125
00G04700141	105	06435-GT4-405	121	06435-MCT-405	181	06455-GCC-B52	709
00G04700141	559	06435-GT4-405	690	06435-MCT-405	654	06455-GCM-900	123
00H001201221	189	06435-HA5-405	592	06435-MEE-006	162	06455-GCM-900	697
00H001201221	821	06435-HA5-670	592	06435-MEE-006	657	06455-GCR-006	119
00H01301931	105	06435-HN8-006	173	06435-MEJ-006	162	06455-GCR-006	688
00H01301931	559	06435-HN8-006	780	06435-MEJ-006	657	06455-GCS-006	125
00H01302551	167	06435-HN8-006	813	06435-MEJ-016	162	06455-GCS-006	709
00H01302551	773	06435-HN8-016	976	06435-MEJ-016	657	06455-GCS-016	125
00H01303551	105	06435-HP1-006	173	06435-MEL-D21	834	06455-GCS-016	709
00H01303551	559	06435-HP1-006	780	06435-MEL-D22	834	06455-GCS-026	125
00H01304931	167	06435-HP1-006	813	06435-MEL-D23	834	06455-GCS-026	709
00H01304931	773	06435-HP5-602	592	06435-MFF-D01	161	06455-GFM-D31	205
00H04702-141	148	06435-HP6-A01	829	06435-MFF-D01	614	06455-GFM-D31	873
00H04702-141	652	06435-K01-D11	193	06435-MFG-D02	834	06455-GZ8-405	694
00H04703141	168	06435-K01-D11	832	06435-MFN-D01	862	06455-HP1-006	694
00H04703141	774	06435-K04-931	193	06435-MFN-D02	862	06455-HP1-016	694
00H047041-41	157	06435-K04-931	832	06435-MFN-D11	862	06455-K01-D11	181
00H047041-41	730	06435-K26-921	915	06435-MFN-D12	862	06455-K01-D11	654
00RTS01A0015	148	06435-K40-F02	193	06435-MGE-D01	892	06455-K40-F11	181
00RTS01A0015	652	06435-K40-F02	832	06435-MGE-D02	892	06455-K40-F11	654
00TRS01A0027	802	06435-K40-F11	193	06435-MGS-D31	881	06455-KBR-731	694
00TRS01-A0046	228	06435-K40-F11	832	06435-MGY-641	862	06455-KCC-841	951
00TRS01-A0046	859	06435-KBS-W00	108	06435-MGZ-J01	881	06455-KCC-842	951
00TRS01A0068	203	06435-KBS-W00	588	06435-MJM-D01	862	06455-KCR-405	181
00TRS01A0068	585	06435-KCZ-000	144	06435-ML7-405	160	06455-KCR-405	654
00TRS01-A0074	228	06435-KCZ-000	604	06435-ML7-405	542	06455-KCZ-000	694
00TRS01-A0074	859	06435-KFG-J21	161	06435-ML7-415	160	06455-KEB-900	163
00TRS01A0075	144	06435-KFG-J21	614	06435-ML7-415	181	06455-KEB-900	713
00TRS01A0075	604	06435-KFK-006	161	06435-ML7-415	542	06455-KEH-900	100
014360258000	168	06435-KFK-006	614	06435-ML7-415	654	06455-KEH-900	536
014360258000	774	06435-KFK-016	161	06435-ML7-P01	181	06455-KFG-016	147
03613-9666	138	06435-KFK-016	614	06435-ML7-P01	654	06455-KFG-016	722

OE No.	SBS No.	OE No.	SBS No.	OE No.	SBS No.	OE No.	SBS No.
06455-KFG-641	147	06455-MAL-G01	183	06455-MKF-D41	947	ODN00G04700141	559
06455-KFG-641	722	06455-MAL-G01	627	06455-MKF-D61	841	10124-29710	235
06455-KFR-701	181	06455-MAN-911	176	06455-MKH-D01	940	10124-29710	969
06455-KFR-701	654	06455-MAN-911	674	06455-MKR-D11	985	102-33870	704
06455-KFR-701	183	06455-MAS-305	622	06455-ML4-P00	593	107-28-86-30	138
06455-KFR-701	627	06455-MAT-006	736	06455-ML7-P10	593	107-28-86-30	519
06455-KHA-941	694	06455-MAT-E21	736	06455-MM5-P00	600	107-5365-13	138
06455-KN8-405	127	06455-MAW-621	181	06455-MR1-405	183	107-5365-13	519
06455-KN8-405	572	06455-MAW-621	654	06455-MR1-405	627	107-6708-21	706
06455-KPB-406	147	06455-MAW-761	694	06455-MR4-405	183	107670823	706
06455-KPB-406	722	06455-MAY-000	694	06455-MR4-405	627	107-684830	711
06455-KPB-416	147	06455-MBB-006	622	06455-MS6-P00	647	107-694-936	157
06455-KPB-416	722	06455-MBE-006	183	06455-MS8-405	647	107-694-936	730
06455-KPC-641	119	06455-MBE-006	627	06455-MT8-405	647	107-861750	151
06455-KPC-641	688	06455-MBG-005	736	06455-MV4	647	107-861750	671
06455-KPH-951	180	06455-MBK-751	181	06455-MV4-405	183	107988210	841
06455-KPH-951	797	06455-MBK-751	654	06455-MV4-405	627	107-A225-40	839
06455-KPM-006	104	06455-MBR-006	676	06455-MW3-405	183	107-A486-02	695
06455-KPM-006	558	06455-MBT-051	192	06455-MW3-405	627	107-A486-03	711
06455-KPN-E01	119	06455-MBT-051	828	06455-MY1-405	694	107-A486-04	805
06455-KPN-E01	688	06455-MBT-611	736	06455-MY5-731	176	107-A486-48	809
06455-KPN-E02	119	06455-MBW-006	734	06455-MY5-731	674	107-A486-49	841
06455-KPN-E02	688	06455-MBW-E11	734	06455-MY9-871	706	107-A486-51	806
06455-KPN-E21	958	06455-MC5-R01	192	06455-MZ0-760	183	107-A486-53	566
06455-KPP-901	180	06455-MC5-R01	828	06455-MZ0-760	627	107-A486-55	864
06455-KPP-901	797	06455-MCA-006	736	06455-MZ0-760	181	114100100000E	203
06455-KR3-000	119	06455-MCA-016	736	06455-MZ0-760	654	114100100000E	585
06455-KR3-000	688	06455-MCB-611	694	06455-MZ1-405	622	1141-40001-100E	163
06455-KR3-405	119	06455-MCC-006	736	06455-MZ2-405	685	1141-40001-100E	713
06455-KR3-405	688	06455-MCH-006	736	06455-MAA-405	181	114140003300A	167
06455-KRE-K01	233	06455-MCK-A01	181	06455-MAA-405	654	114140003300A	773
06455-KRE-K01	964	06455-MCK-A01	654	06455-NX4-860	782	1160	167
06455-KRM-861	100	06455-MCS-G01	736	06455-NX7-006	782	1160	773
06455-KRM-861	536	06455-MCS-G02	736	06456-MAW-761	694	11933400	132
06455-KSE-006	592	06455-MCS-R01	192	06456-MCA-006	736	11933400	595
06455-KSE-016	592	06455-MCS-R01	828	06456-MCB-611	694	119-363-00	109
06455-KSS-952	694	06455-MCT-691	736	06456-MCB-612	694	119-363-00	607
06455-KSV-J01	192	06455-MCW-H01	192	06456-MCC-006	736	11940100	118
06455-KSV-J01	828	06455-MCW-H01	828	06456-MCW-H01	192	11940100	684
06455-KSV-J03	192	06455-MCZ-006	622	06456-MCW-H01	828	119-419-000	109
06455-KSV-J03	828	06455-MEA-671	181	06456-MEH-006	192	119-419-000	607
06455-KSV-J41	192	06455-MEA-671	654	06456-MEH-006	828	119-439-00	123
06455-KSV-J41	828	06455-MEH-006	192	06456-MFF-D01	192	119-439-00	697
06455-KTK-006	119	06455-MEH-006	828	06456-MFF-D01	828	119-468-00	123
06455-KTK-006	688	06455-MEL-003	809	07009R	566	119-468-00	697
06455-KTW-901	192	06455-MEL-013	809	07010R	109	119-468-000	109
06455-KTW-901	828	06455-MEL-D22	809	07010R	607	119-468-000	607
06455-KW6-843	119	06455-MET-651	192	07-020-016	855	119-481-00	159
06455-KW6-843	688	06455-MET-651	828	0722189	843	119-481-00	761
06455-KW6-844	119	06455-MFA-D11	192	072223	843	119-481-00	147
06455-KW6-844	688	06455-MFA-D11	828	07-6708-21	706	119-481-00	722
06455-KWF-951	180	06455-MFA-D12	192	07-684831	695	11948600	152
06455-KWF-951	797	06455-MFA-D12	828	07-7874-24	805	11948600	747
06455-KWN-641	205	06455-MFJ-D01	809	07-8354-24	845	119-491-00	152
06455-KWN-641	873	06455-MFR-A01	192	07-8366-30	889	119-491-00	747
06455-KWN-901	228	06455-MFR-A01	828	07849312/27	791	119-493-00	168
06455-KWN-901	859	06455-MGE-006	869	0784931V27	151	119-493-00	774
06455-KWN-931	205	06455-MGE-016	869	0784931V27	671	119-495-00	168
06455-KWN-931	873	06455-MGP-081	841	07881950	706	119-495-00	774
06455-KYJ-901	183	06455-MGS-D31	181	078819RC	706	119-502-00	123
06455-KYJ-901	627	06455-MGS-D31	654	07883050	841	119-502-00	697
06455-KZL-861	205	06455-MGS-D32	181	0795-39-856	506	119-52200	138
06455-KZL-861	873	06455-MGS-D32	654	07-9882-10	841	119-52200	519
06455-MAB-405	181	06455-MGS-D81	192	07BB2010	157	11955600	105
06455-MAB-405	654	06455-MGS-D81	828	07BB2010	730	11955600	559
06455-MAH-405	181	06455-MJE-D02	183	07BB2050	157	11955700	168
06455-MAH-405	654	06455-MJE-D02	627	07BB2050	730	11955700	774
06455-MAJ-G41	685	06455-MJF-D02	809	07BB30RC	841	11966900	105
06455-MAJ-G41	736	06455-MJM-D31	809	09130-07E00	157	11966900	559
06455-MAK-000	176	06455-MJM-D41	947	09130-07E00	730	11967300	167
06455-MAK-000	674	06455-MJP-G51	940	0960-39-656	506	11967300	773
06455-MAK-003	176	06455-MKC-A01	952	0979-39-856	506	11967800	168
06455-MAK-003	674	06455-MKF-061	841	ODN00G04700141	105	11967800	774

OE No.	SBS No.	OE No.	SBS No.	OE No.	SBS No.	OE No.	SBS No.
119-69800	163	1B9-W0045-00	194	1UY-W0046-00	592	2204724	674
119-69800	713	1B9-W0045-00	837	1V1-W0045-00	500	2205606	899
11969900	107	1C3-W0046-00	790	1WD-25805-00	227	2205949	954
11969900	575	1C3-W0046-B0	790	1WD-25805-00	229	2206025	970
11D-FS811-00	151	1C0-25806-00	155	1WD-25805-00	858	2207667	977
11D-FS811-00	671	1C0-25806-00	728	1WD-25805-00	931	2208161	978
11H-W0045-00	550	1D2-W0045-00	706	1WD-25806-00	230	22B-FS811-00	183
11H-W0045-01	550	1D4-F5742-00	167	1WD-25806-00	932	22B-FS811-00	627
11L-W0045-00	550	1D4-F5742-00	773	1WS-25805-00	198	22U-W0045-10	550
11U-W0045-00	550	1D5-F5811-00	168	1WS-25805-00	634	238-070-5-6340	108
11U-W0045-10	550	1D5-F5811-00	774	1XD-25805-00-00	971	238-070-5-6340	588
1-290025	211	1D7-25806-00	769	1XD-25805-10	137	238-07-6340	541
1-290025	882	1D7-W0046-00	769	1XD-25805-10	650	238-076570	106
12906040	138	1DK-W0045-00	183	1XD-25805-10-00	972	238-076570	574
12906040	519	1DK-W0045-00	627	1XD-25806-00	134	23W-W0045-01	547
1296006	138	1FK-W0045-00	555	1XD-25806-00	638	23W-W0045-10	547
1296006	519	1FK-W0045-10	555	1XD-25806-00-00	973	240-07-6340	541
1296007	656	1FK-W0046-01	555	1XD-25806-10	197	245-07-6340	106
1296033	656	1FK-W0046-02	555	1XD-25806-10	611	245-07-6340	574
13D-FS811-00	168	1J3-20000-11	507	1XD-25806-10-00	974	25.25362	790
13D-FS811-00	774	1J3-20000-13	507	2020073-T0301	624	251-0037-A	103
140330	111	1J3-20000-63	507	20S-W0046-00	161	251-0037-A	551
140330	619	1J3-20000-64	507	20S-W0046-00	614	252-0033A	119
14140001000E	103	1J3-20000-70	507	211021021	566	252-0033A	688
14140001000E	551	1J3-W0045-00	507	211021022	138	2525230000	148
1436-165	822	1J3-W0046-00	507	211021022	519	2525230000	652
1436-420	822	1J9-20000-02	507	211021038	175	2525240000	138
14654601	506	1KT-W0046-50	570	211021038	675	2525240000	519
14654650	506	1KT-W0046-51	570	211041010	566	2525240000	123
1502-694	822	1KT-W0046-52	570	211082009	566	2525240000	697
153-W0045-10	134	1L9-W0045-00	507	211082010	138	2525241000	105
153-W0045-10	638	1L9-W0046-00	507	211082010	519	2525241000	559
159-07-6340	108	1LN-W0045-01	580	211082018	706	2525-242000	138
159-07-6340	588	1LR-W0046-00	136	21330710000019	105	2525-242000	519
1677	168	1LR-W0046-00	589	21330710000019	559	2525250000	109
1677	774	1LX-W0045-00	580	2133071-00003	105	2525250000	607
1679	151	1NL-W0045-00	590	2133071-00003	559	2525340000	168
1679	671	1NL-W0045-01	590	214-007-1000002	148	2525340000	774
1799-0078	739	1P1-W0046-00	196	214-007-1000002	652	2525350000	105
1799-0079	739	1P1-W0046-00	754	219800237	900	2525350000	559
18654660	554	1PH-F5805-00	123	2200418	717	25-25352	802
1910032	717	1PH-F5805-00	697	2200464	717	2525352000	802
1910036	642	1PH-F5806-00	145	2200465	642	25-25363	896
1910042	642	1PH-F5806-00	731	2200807	756	2525370000	123
1910051	717	1RK-W0045-00	590	2200899	717	2525370000	697
1910129	642	1RK-W0045-50	590	2200901	642	2525371000	152
1910333	642	1RK-W0046-00	590	2201093	755	2525371000	747
1910339	755	1S3-W0046-00	816	2201149	642	25-25373	896
1910450V	757	1S3-W0046-00	767	2201170	706	2547/F/S	138
1910514	800	1S4-W0045-00	119	2201189	755	2547/F/S	519
1910683	787	1S4-W0045-00	688	2201398	642	2654F/S/R2	631
1911171	642	1S6-W0045-00	181	2201399	755	266-07-6340	132
1911197	898	1S6-W0045-00	654	2201685	757	266-07-6340	595
193	123	1S9-F530K-00	227	2201749	757	268	123
193	697	1S9-F530K-00	858	2201871	787	268	697
1930626	717	1SC-F5806-00	135	2202097	800	26H-W0045-00	555
1930643	642	1SC-F5806-00	546	2202411	755	26H-W0045-01	555
1930644	717	1SD-F5911-00	195	2202412	755	26H-W0045-10	555
1930731	642	1SD-F5911-00	863	2202412	642	26H-W0045-11	555
1930741	717	1SD-F5911-10	155	2202413	800	26H-W0046-00	555
1930815	642	1SD-F5911-10	728	2202414	787	26H-W0046-01	555
1930860	755	1U4-W0046-01	507	2202491	176	27-69173	566
19654600	138	1U4-W0046-02	507	2202491	674	28000214	900
19654600	519	1UF-W0045-00	555	2202492	706	29-001	656
1965-4600	138	1UF-W0045-01	555	2203045	822	29L-W0045-00	550
1965-4600	519	1UY-W0045-00	107	2203318	898	29L-W0045-10	550
19654601	138	1UY-W0045-00	575	2203452	642	29L-W0045-10	555
19654601	519	1UY-W0045-01	107	2203628	899	29L-W0046-01	555
1A1-W0045-00	504	1UY-W0045-01	575	22037-47	897	2C8-W0045-00	176
1B7-W0045-00	128	1UY-W0045-02	107	2203792	642	2C8-W0045-00	674
1B7-W0045-00	691	1UY-W0045-02	575	2203930	898	2CM-F-580500	223
1B7-W0046-00	185	1UY-W0045-03	107	2204088	899	2CM-F-580500	937
1B7-W0046-00	812	1UY-W0045-03	575	2204724	176	2CM-F5805-10	222

OE No.	SBS No.	OE No.	SBS No.	OE No.	SBS No.	OE No.	SBS No.
2CM-F5805-10	936	3303-908	810	34 21 2 335 465	742	3CS-25805-00	728
2CO-25805-00	198	3304-567	154	34 21 7 657 025	506	3CS-W0045-00	155
2CO-25805-00	634	3304-567	749	34 21 7 657 492	746	3CS-W0045-00	728
2CR-25806-00	834	3305-139	154	34 21 7 660 281	742	3D6-F5811-00	167
2DL-F5811-00	221	3305-139	749	34 21 7 671 246	746	3D6-F5811-00	773
2DL-F5811-00	935	3380925	105	34 21 7 680 374	746	3D7-W0045-10	183
2DP-F580500	226	3380925	559	34 21 7 680 375	746	3D7-W0045-10	627
2DP-F580500	943	3380928	105	34 21 7 717 324	791	3D8-25806-00	769
2G2-W0045-00	528	3380928	559	34 21 7 724 609	176	3EN-W0045-00	590
2G2-W0045-01	545	33M-W0045-01	555	34 21 7 724 609	674	3FV-W0045-00	624
2G2-W0045-10	545	33M-W0045-10	555	34 21 8 534 821	176	3FY-W0045-00	107
2GH-W0045-00	590	34 1 2 301 360	506	34 21 8 534 821	674	3FY-W0045-00	575
2GH-W0045-01	590	34 11 1 233 319	520	34 21 8 554 424	176	3G1-W0046-00	507
2HC-25805-00-00	979	34 11 1 238 083	527	34 21 8 554 424	674	3GD-W0045-00	100
2HC-25806-00-00	980	34 11 1 354 720	554	34 21 8 556 442	742	3GD-W0045-00	536
2HF-W0046-00	136	34 11 1 451 995	506	34 21 8 562 163	176	3GM-W0045-00	645
2HF-W0046-00	589	34 11 1 454 724	506	34 21 8 562 163	674	3GM-W0045-01	645
2HF-W0046-02	136	34 11 1 458 388	506	34 71 2 301 359	527	3GM-W0045-11	645
2HF-W0046-02	589	34 11 2 301 358	520	3406-031	592	3GM-W0045-50	665
2HH-W0045-00	580	34 11 2 310 494	640	3406-032	592	3H5-W0045-00	507
2HH-W0045-01	580	34 11 2 310 601	554	3406-075	649	3H5-W0045-01	507
2HR-W0045-00	576	34 11 2 310 983	703	34111542307	985	3H6-W0045-00	528
2J2-W0046-00	507	34 11 2 310494	118	341-170	138	3HE-W0045-00	555
2J2-W0046-01	507	34 11 2 310494	684	341-170	519	3HE-W0045-11	555
2KJ-W0045-00	550	34 11 2 311 175	640	341878	608	3J6-W0045-01	528
2MO-W0046-00	507	34 11 2 314 512	703	34211542313	984	3J6-W0045-10	545
2MO-W0046-01	507	34 11 2 314 545	554	344839	108	3J6-W0045-11	545
2MP-W0045-00	227	34 11 2 314 546	640	344839	588	3JB-W0045-00	616
2MP-W0045-00	858	34 11 2 314 996	703	344-840	107	3JD-W0045-00	197
2NA-W0045-01	111	34 11 2 331 173	703	344-840	575	3JD-W0045-00	611
2NA-W0045-01	619	34 11 2 331 175	640	3499074	105	3JD-W0045-10	134
2R6-W0045-00	531	34 11 2 331 177	554	3499074	559	3JD-W0045-10	638
2R6-W0045-10	531	34 11 2 333 045	703	34L-W0045-10	550	3JD-W0046-00	198
2R6-W0045-11	531	34 11 2345 445	176	34X-W0046-00	107	3JD-W0046-00	634
2R6-W0045-12	531	34 11 2345 445	674	34X-W0046-00	575	3JD-W0046-00	584
2R8-W0045-003	528	34 11 7 651 958	176	34X-W0046-01	107	3JD-W0046-01	584
2UJ-W0045-00	550	34 11 7 651 958	674	34X-W0046-01	575	3JD-W0046-10	584
2UJ-W0045-01	550	34 11 7 655 687	703	34X-W0046-02	107	3JH-W0045-00	107
2VN-W0046-00	107	34 11 7 655 898	743	34X-W0046-02	575	3JH-W0045-00	575
2VN-W0046-00	575	34 11 7 658 156	703	3500000	210	3LC-25811-00	624
2VN-W0046-01	107	34 11 7 658 386	743	3500000	878	3LC-25811-50	659
2VN-W0046-01	575	34 11 7 660 340	176	359-1-40-280-0	532	3LC-W0046-00	659
2VW-F0047-00	608	34 11 7 660 340	674	359-1-40-283-1	532	3LD-W0045-10	119
2XJ-25811-00	637	34 11 7 660 448	796	36H-W0046-01	555	3LD-W0045-10	688
305128A-003103	163	34 11 7 663 764	703	3710	151	3LD-W0045-30	119
305128A-003103	713	34 11 7 671 780	796	3710	671	3LD-W0045-30	688
306-25811-00	504	34 11 7 683 064	796	3711	791	3LD-W0046-01	633
306-25811-01	504	34 11 7 69 65 93	706	37A-W0045-00	555	3LN-W0045-00	639
306-25811-02	504	34 11 7 690 169	743	37P-F5811-00	181	3MA-W0045-00	198
306-25811-03	504	34 11 7 690 170	743	37P-F5811-00	654	3MA-W0045-00	634
306-25811-04	504	34 11 7 697 086	176	37P-W0046-00	155	3MW-W0045-00	624
306-25811-05	504	34 11 7 697 086	674	37P-W0046-00	728	3P6-W0046-50	769
306-25811-06	504	34 11 7 705 216	176	38A-W0045-01	555	3SH-F5811-00	118
310-292	560	34 11 7 705 216	674	38W-W0045-00	107	3SH-F5811-00	684
31A-W0046-00	555	34 11 7 711 498	176	38W-W0045-00	575	3SH-F5811-20	138
31A-W0046-10	555	34 11 7 711 498	674	38W-W0045-01	107	3SH-F5811-20	519
32176F	848	34 11 7 711 498	706	38W-W0045-01	575	3SP-W0045-00	197
32176G	848	34 11 7 717 292	151	39P-W0045-00	198	3SP-W0045-00	611
3220505A	914	34 11 7 717 292	671	39P-W0045-00	634	3SP-W0046-00	648
322050A	914	34 11 7 717 308	151	3B4-W0045-00	850	3TB-W0045-00	137
323-627	138	34 11 7 717 308	671	3B4-W0045-10	849	3TB-W0045-00	650
323-627	519	34 11 7 728 945	778	3B4-W0046-10	851	3TC-W0045-00	624
326-446	138	34 11 710 743	841	3B4-W0046-10	852	3TJ-W0045-00	198
326-446	519	34 11 8 405 104	960	3BN-W0045-00	107	3TJ-W0045-00	634
326-478	106	34 11 8 534 183	796	3BN-W0045-00	575	3TJ-W0046-00	570
326-478	574	34 11 8 535 158	900	3BN-W0045-01	107	3UH-W0045-00	107
326-814	108	34 11 8 540 956	900	3BN-W0045-01	575	3UH-W0045-00	575
326-814	588	34 11 8 548 028	900	3C1-F5805-10	227	3UN-W0045-00	136
3-290055	211	34 21 1 236 221	506	3C1-F5805-10	858	3UN-W0045-00	589
3-290055	882	34 21 2 314 997	742	3C1-W0045-10	227	3XF-W0045-00	555
32D-W0045-00	694	34 21 2 330 633	742	3C1-W0045-10	858	3XG-W0045-00	111
3303-446	154	34 21 2 332 988	506	3CL-W0046-00	659	3XG-W0045-00	619
3303-446	749	34 21 2 333 337	746	3CS-25805-00	155	3XL-W0045-00	550



OE No.	SBS No.	OE No.	SBS No.	OE No.	SBS No.	OE No.	SBS No.
3XP-W0045-00	107	43050-010	512	43082-0078	798	43082-0173	183
3XP-W0045-00	575	43050-011	510	43082-0079	183	43082-0173	627
3XP-W0045-00	197	43050-1006	514	43082-0079	627	43082-0179	163
3XP-W0045-00	611	43050-1006	510	43082-0080	134	43082-0179	713
3XP-W0046-00	648	43050-1007-A	522	43082-0080	638	43082-039	886
3XP-W0046-00	107	43050-1007-B	522	43082-0080	119	43082-1001	510
3XP-W0046-00	575	43050-1008	514	43082-0080	688	43082-1003	556
3YF-W0045-00	137	43050-1009	516	43082-0081	119	43082-1004	530
3YF-W0045-00	650	43050-1010	516	43082-0081	688	43082-1005	510
3YK-W0045-01	123	43050-1013	512	43082-0082	197	43082-1007	539
3YK-W0045-01	697	43050-1021	510	43082-0082	611	43082-1008	539
3YR-W0045-00	155	43050-1040	101	43082-0087	197	43082-1021	539
3YR-W0045-00	728	43050-1040	544	43082-0087	611	43082-1022	539
3YX-W0045-00	170	43050-1043	101	43082-0090	144	43082-1025	539
3YX-W0045-00	663	43050-1043	544	43082-0090	604	43082-1026	539
404-2000-11	500	43050-1044	101	43082-0091	806	43082-1027	135
404-2000-12	500	43050-1044	544	43082-0099	197	43082-1027	546
404210-TAC-000	141	43050-1048	101	43082-0099	611	43082-1028	100
404210-TAC-000	723	43050-1048	544	43082-0100	197	43082-1028	536
404-W0045-12	500	43050-1051	101	43082-0100	611	43082-1029	557
4084	101	43050-1051	544	43082-0105	886	430821031	135
4084	544	43050-1063	135	43082-0107-855852	790	430821031	546
4084-43D-F5906-00	101	43050-1063	546	43082-0111	687	43082-1031	557
4084-43D-F5906-00	544	43050-1064	135	43082-0113	806	43082-1051	135
409-25811-00	504	43050-1064	546	43082-0115	834	43082-1051	546
409-25811-01	504	43050-1073	135	43082-0116	886	43082-1056	135
409-W0045-00	504	43050-1073	546	43082-0117	161	43082-1056	546
41300027	922	43050-1082	135	43082-0117	614	43082-1057	557
41300033	923	43050-1082	546	43082-0119	687	43082-1058	530
41300053	715	43050-1126	101	43082-0123	704	43082-1059	512
41300072	924	43050-1126	544	43082-0124	886	43082-1061	557
41300102	734	43050-1169	101	43082-0124	704	43082-1062	557
41300161	151	43050-1169	544	43082-0126	134	43082-1063	135
41300161	671	43050-5001	510	43082-0126	638	43082-1063	546
41300169	176	43050-5002	514	43082-0128	119	43082-1064	135
41300169	674	43050-5002	510	43082-0128	688	43082-1064	546
41300197	949	43050-5003	510	43082-0129	782	43082-1065	101
41300227	900	43050-5004	522	43082-0131	734	43082-1065	544
41300230	157	43051-001	503	43082-0132	694	43082-1066	592
41300230	730	43051-001	510	43082-0134	216	43082-1067	591
41300241	175	43051-006	510	43082-0134	925	43082-1068	597
41300241	675	43051-007	510	43082-0138	134	43082-1069	597
413610	203	43051-008	510	43082-0138	638	43082-1070	135
413610	585	43051-009	514	43082-0140	810	43082-1070	546
414220	210	43051-011	510	43082-0144	806	43082-1072	602
414220	878	43063-83	579	43082-0146	197	43082-1073	135
41852-08B	830	43071-001	503	43082-0146	611	43082-1073	546
42029-07	808	43082-0002	782	43082-0147	806	43082-1074	597
42298-08	854	43082-0004	687	43082-0150	183	43082-1075	615
42385-94Y	692	43082-0006	790	43082-0150	627	43082-1076	615
42385-98Y	161	43082-0009	705	43082-0151	615	43082-1077	597
42385-98Y	614	43082-001	503	43082-0151	161	43082-1078	602
42386-84Y	658	43082-001	510	43082-0151	614	43082-1079	101
42386-984	676	43082-0010	704	43082-0152	147	43082-1079	544
4252	885	43082-0015	886	43082-0152	722	43082-1080	557
42739-008	734	43082-0015	631	43082-0153	631	43082-1081	101
42739-08	860	43082-0016	631	43082-0155	162	43082-1081	544
42831-04	807	43082-0026	694	43082-0155	657	43082-1082	592
42831-04A	807	43082-0042	752	43082-0157	841	43082-1083	101
42836-04	808	43082-0043	100	43082-0158	157	43082-1083	544
42850-06	830	43082-0043	536	43082-0158	730	43082-1084	135
43020-CEK-000	134	43082-0048	790	43082-0162	841	43082-1084	546
43020-CEK-000	638	43082-0049	694	43082-0165	183	43082-1085	615
43020-S020	162	43082-0052	886	43082-0165	627	43082-1086	135
43020-S020	657	43082-0055	715	43082-0166	162	43082-1086	546
43050-001	503	43082-0060	163	43082-0166	657	43082-1087	615
43050-002	510	43082-0060	713	43082-0167	687	43082-1088	597
43050-002	503	43082-0063	886	43082-0168	782	43082-1089	197
43050-005	510	43082-0063	704	43082-0169	147	43082-1089	611
43050-006	510	43082-0069	134	43082-0169	722	43082-1090	632
43050-007	510	43082-0069	638	43082-0171	841	43082-1092	135
43050-008	510	43082-0073	162	43082-0172	119	43082-1092	546
43050-009	510	43082-0073	657	43082-0172	688	43082-1093	197



OE No.	SBS No.	OE No.	SBS No.	OE No.	SBS No.	OE No.	SBS No.
43082-1093	611	43082-1201	536	43082-Y005	183	43105-MB4-008	542
43082-1094	134	43082-1203	704	43082-Y005	627	43105-MB4-305	160
43082-1094	638	43082-1204	135	43082-Y006	195	43105-MB4-305	542
43082-1095	597	43082-1204	546	43082-Y006	204	43105-MB6-018/008	160
43082-1096	135	43082-1205	592	43082-Y006	863	43105-MB6-018/008	542
43082-1096	546	43082-1206	726	43082-Y006	871	43105-MG9-007/017	160
43082-1097	631	43082-1208	631	43082-Y007	183	43105-MG9-007/017	542
43082-1098	556	43082-1213	687	43082-Y007	627	43105-MJ4-007	573
43082-1101	615	43082-1217	743	43082-Y008	204	43105-MJ4-008	573
43082-1102	631	43082-1218	694	43082-Y008	871	43105-MJ6-721/722/723	127
43082-1103	556	43082-1223	705	430-82-Y008	204	43105-MJ6-721/722/723	572
43082-1104	597	43082-1224	686	430-82-Y008	871	43105-MJ6-724	127
43082-1110	631	43082-1226	704	43-09-11	560	43105-MJ6-724	572
43082-1111	631	43082-1227	686	43105-1EE8-305	810	43105-ML7-006	160
43082-1113	631	43082-1228	144	43105-461-305	508	43105-ML7-006	542
43082-1114	597	43082-1228	604	43105-461-770	517	43105-ML7-007	160
43082-1115	101	43082-1230	686	43105-461-771	508	43105-ML7-007	542
43082-1115	544	43082-1232	704	43105-461-772	508	43105-ML7-017	160
43082-1117	197	43082-1234	705	43105-ARB-000A	142	43105-ML7-017	542
43082-1117	611	43082-1235	704	43105-ARB-000A	724	43105-ML7-027	160
43082-1118	632	43082-1238	119	43105-GT4-004A	144	43105-ML7-027	542
43082-1120	631	43082-1238	688	43105-GT4-004A	604	43105-ML7-921A	181
43082-1123	597	43082-124	694	43105-GW2-004A	144	43105-ML7-921A	654
43082-1124	597	43082-1241	100	43105-GW2-004A	604	43105-ML7-922A	181
43082-1125	615	43082-1241	536	43105-HB9-008	104	43105-ML7-922A	654
43082-1127	615	43082-1242	752	43105-HB9-008	558	43105-MN5-008	160
43082-1129	197	43082-1243	704	43105-HE0-305	610	43105-MN5-008	542
43082-1129	611	43082-1244	705	43105-HMA-00DA	201	43105-MN8-006	161
43082-1130	666	43082-1246	704	43105-HMA-00DA	847	43105-MN8-006	614
43082-1131	632	43082-1248	704	43105-KBF-3050-MZ	129	43105-MR7-007A	623
43082-1134	597	43082-1250	686	43105-KBF-3050-MZ	710	43105-MR7-017A	623
43082-1137	632	43082-1251	686	43105-KBF-9000	129	43105-MS2-007A	181
43082-1139	597	43082-1253	686	43105-KBF-9000	710	43105-MS2-007A	654
43082-1141	556	43082-1255	801	43105-KBS-405	646	43105-MS9-612A	181
43082-1142	631	43082-1257	556	43105-KBS-W00	646	43105-MS9-612A	654
43082-1144	615	43082-1259	686	43105-KK9-691	598	43105-MT3/6-007	181
43082-1147	615	43082-1260	704	43105-KKC4-9000	172	43105-MT3/6-007	654
43082-1148	687	43082-1265	704	43105-KKC4-9000	776	43105-MT4-007A	181
43082-1151	632	43082-1266	694	43105-KN8-007	127	43105-MT4-007A	654
43082-1152	694	43082-1267	144	43105-KN8-007	572	43105-MT7-405	623
43082-1157	687	43082-1267	604	43105-KS6-701A	144	43105-MT8-008	160
43082-1160	687	43082-1272	686	43105-KS6-701A	604	43105-MT8-008	542
43082-1161	597	43082-1273	798	43105-KS6-702A	144	43105-MW0-405	162
43082-1162	615	43082-1274	686	43105-KS6-702A	604	43105-MW0-405	657
43082-1163	135	43082-1280	704	43105-KT7-761A	161	43105-MW0-425	162
43082-1163	546	43082-1282	705	43105-KT7-761A	614	43105-MW0-425	657
43082-1164	101	43082-1283	704	43105-KT7-762A	161	43105-MY1-405	161
43082-1164	544	43082-1286	694	43105-KT7-762A	614	43105-MY1-405	614
43082-1167	557	43082-1288	631	43105-KV3-831	161	43105-MY6-415	144
43082-1169	631	43082-1290	782	43105-KV3-831	614	43105-MY6-415	604
43082-1171	687	43082-1291	556	43105-KY4-901	646	43105-MY7-405	181
43082-1172	694	43082-1292	144	43105-KY4-902	646	43105-MY7-405	654
43082-1173	144	43082-1292	604	43105-KZ1-405	144	43105-NF5-611	110
43082-1173	604	43082-5006	592	43105-KZ1-405	604	43105-NF5-611	618
43082-1177	705	43082-5010	144	43105-LBA2-305	212	43105-NF5-612	110
43082-1178	704	43082-5010	604	43105-LBA2-305	883	43105-NF5-612	618
43082-1179	686	43082-5012	144	43105-LDH1-E00	195	43105-NN2-600	138
43082-1180	556	43082-5012	604	43105-LDH1-E00	863	43105-NN2-600	519
43082-1181	676	43082-S001	122	43105-LDH1-E00	119	43105-NN3-820	803
43082-1182	715	43082-S001	702	43105-LDH1-E00	688	43105-NN3-830	803
43082-1187	705	43082-S005	122	43105-LDH-1E00	201	43105-NW2-610	646
43082-1188	704	43082-S005	702	43105-LDH-1E00	847	43105-SABA-ZOOM1	119
43082-1189	597	43082-S007	649	43105-LEA7-305	204	43105-SABA-ZOOM1	688
43082-1191	135	43082-S009	694	43105-LEA7-305	871	43105-SZ2-0000	201
43082-1191	546	43082-S011	694	43105-LFC4-305	119	43105-SZ2-0000	847
43082-1193	694	43082-S015	122	43105-LFC4-305	688	43105-SZ2-0010	201
43082-1194	557	43082-S015	702	43105-LGE5-305	195	43105-SZ2-0010	847
43082-1196	726	43082-S018	704	43105-LGE5-305	863	43105-VM0-008	610
43082-1199	686	43082-S019	705	43105-LKF-305	212	43105-VM0-771	610
43082-120	135	43082-Y001	154	43105-LKF-305	883	43106-961-006	592
43082-120	546	43082-Y001	749	43105-MB4-007/017	160	43106-GT4-004B	144
43082-1200	556	43082-Y003	810	43105-MB4-007/017	542	43106-GT4-004B	604
43082-1201	100	43082-Y004	810	43105-MB4-008	160	43106-GW2-004B	144

OE No.	SBS No.	OE No.	SBS No.	OE No.	SBS No.	OE No.	SBS No.
43106-GW2-004B	604	43957-86	668	45105-443-762	572	45105-HA2-671	558
43106-KS6-701B	144	43957-86A	668	45105-471-006	526	45105-H-A3-A-000	178
43106-KS6-701B	604	43957-86B	668	45105-961-000	592	45105-H-A3-A-000	792
43106-KS6-702B	144	43957-86D	668	45105-961-006	562	45105-HA5-671A	139
43106-KS6-702B	604	43957-86E	668	45105-ACL1-305	945	45105-HA5-671A	603
43106-KT7-761B	161	43D-F5906-01	135	45105-APA000A	140	45105-HA5-672A	139
43106-KT7-761B	614	43D-F5906-01	546	45105-APA000A	708	45105-HA5-672A	603
43106-KT7-762B	161	43F-W0045-00	550	45105-BA5-RB10M1	181	45105-HA5-672B	139
43106-KT7-762B	614	43F-W0045-00	555	45105-BA5-RB10M1	654	45105-HA5-672B	603
43106-KV3-831	161	43F-W0045-01	550	45105-BM9-741	110	45105-HB9-008	104
43106-KV3-831	614	44005-74	513	45105-BM9-741	618	45105-HB9-008	558
43106-KW3-006B	629	44005-78	513	45105-BM9-742	110	45105-HHA-000A	140
43106-KZ9-006B	629	44032-77	537	45105-BM9-742	618	45105-HHA-000A	708
43106-ML7-921B	181	44032-79	537	45105-BM9-743	110	45105-KA3-731	104
43106-ML7-921B	654	44063-83A	579	45105-BM9-743	618	45105-KA3-731	558
43106-MN8-006	161	44063-83B	579	45105-DE3-A00	119	45105-KAS-415	694
43106-MN8-006	614	44063-83C	579	45105-DE3-A00	688	45105-KAZ-004	183
43106-MR7-007B	623	44063-83E	579	45105-G02-000	115	45105-KAZ-004	627
43106-MR7-017B	623	44082-00	826	45105-G02-000	670	45105-KB9-960	108
43106-SABA-ZOOM1	119	44082-00C	826	45105-G02-000-AS	140	45105-KB9-960	588
43106-SABA-ZOOM1	688	44082-08	853	45105-G02-000-AS	708	45105-KBE-3050-M2	119
43108-H3C-000A	119	44135-74	513	45105-G04-601	104	45105-KBE-3050-M2	688
43108-H3C-000A	688	44135-78	513	45105-G04-601	558	45105-KBS-405	108
43108-HMA-000A	170	44203-115-0000	816	45105-G22-000-AC	140	45105-KBS-405	588
43108-HMA-000A	663	44203-0SB-0000	100	45105-G22-000-AC	708	45105-KCE-3050-M2	163
43108-HWW-000A	201	44203-0SB-0000	536	45105-G22-000-AC	115	45105-KCE-3050-M2	713
43108-HWW-000A	847	44209-82	549	45105-G22-000-AC	670	45105-KE1-742	104
4310A-BA4-000M1	119	44209-82A	549	45105-GAZ-5000-EU	115	45105-KE1-742	558
4310A-BA4-000M1	688	44209-87B	669	45105-GAZ-5000-EU	670	45105-KE1-743	104
4312016900B	101	44209-87C	669	45105-GAZ-9800	115	45105-KE1-743	558
4312016900B	544	44213-87	669	45105-GAZ-9800	670	45105-KE1-744	104
43120-214-00-AEON	906	44281-74	679	45105-GBF-405	100	45105-KE1-744	558
43120-256-000	848	44442-00	826	45105-GBF-405	536	45105-KECE-305M2	163
43120-965-000	562	44603-0580000	767	45105-GBF-405	592	45105-KECE-305M2	713
43120-HA5-305	592	4466-/-4477	707	45105-GC4-601	100	45105-KED9-305	181
43120-HA5-670	592	45102-393-700	501	45105-GC4-601	536	45105-KED9-305	654
43120-HC0-007	562	45105-006/016/026	127	45105-GC4-601	592	45105-KFA6-305	154
43121-205-001-AEON	905	45105-006/016/026	572	45105-GC4-602/603	100	45105-KFA6-305	749
43150-KBE-3060	119	45105-166-007	100	45105-GC4-602/603	536	45105-KFA6-3050	154
43150-KBE-3060	688	45105-166-007	536	45105-GC4-602/603	592	45105-KFA6-3050	749
43150-LDHIE-00	119	45105-300-040	502	45105-GE2-004	103	45105-KK4-004	103
43150-LDHIE-00	688	45105-323-006	501	45105-GE2-004	551	45105-KK4-004	551
43150-LEA5-306	119	45105-323-013	501	45105-GE2-006	103	45105-KK4-007	103
43150-LEA5-306	688	45105-323-016	501	45105-GE2-006	551	45105-KK4-007	551
43150-LLS-3050	119	45105-323-023	501	45105-GE2-305	103	45105-KK4-014	103
43150-LLS-3050	688	45105-323-036	501	45105-GE2-305	551	45105-KK4-014	551
431A0-431-673	509	45105-323-043	501	45105-GE3-601	100	45105-KKD-6305	163
431A0-965-000	562	45105-341-000	502	45105-GE3-601	536	45105-KKD-6305	713
431A0-965-670	562	45105-341-003	502	45105-GE3-602	100	45105-KL8-004	127
431A0-HA5-670	592	45105-341-305	502	45105-GE3-602	536	45105-KL8-004	572
431A0-HB9-008	104	45105-371-000	517	45105-GH9-710	110	45105-KL8-007	127
431A0-HB9-008	558	45105-390-003	501	45105-GH9-710	618	45105-KL8-007	572
431A0-HEO-670	610	45105-390-006	501	45105-GM9-711	112	45105-KL8-014	127
431-A0-MC7-024	127	45105-390-305	501	45105-GM9-711	628	45105-KL8-014	572
431-A0-MC7-024	572	45105-410-004	508	45105-GM9-712	112	45105-KL8-405	127
431A0-MN5-670	160	45105-410-006	508	45105-GM9-712	628	45105-KL8-405	572
431A0-MN5-670	542	45105-410-007	508	45105-GM9-743A	110	45105-KL8-712	127
431A0-MT4-670	181	45105-410-016	508	45105-GM9-743A	618	45105-KL8-712	572
431A0-MT4-670	654	45105-410-026	508	45105-GN3-701	112	45105-KM1-004	104
431A0-VM0-008	610	45105-410-305	508	45105-GN3-701	628	45105-KM1-004	558
43211-371-006	509	45105-413-003	526	45105-GN3-704	112	45105-KM1-007	104
43211-392-006	509	45105-413-305	526	45105-GN3-704	628	45105-KM1-007	558
43211-392-016	509	45105-413-871	526	45105-GW6-004	100	45105-KM1-710	104
43211-431-671	509	45105-415-004	508	45105-GW6-004	536	45105-KM1-710	558
43211-431-672	509	45105-415-006	508	45105-GZO-ACA	115	45105-KM1-711	104
43211-431-673	509	45105-415-305	508	45105-GZO-ACA	670	45105-KM1-711	558
43235-FYBQ-300	100	45105-415-770	508	45105-H13-000-AC	140	45105-KM1-712	104
43235-FYBQ-300	536	45105-415-772	508	45105-H13-000-AC	708	45105-KM1-712	558
43251-KTW-901	193	45105-425-003	526	45105-H3A-900A	178	45105-KN8-007	127
43251-KTW-901	832	45105-425-006	526	45105-H3A-900A	792	45105-KN8-007	572
43395-80	543	45105-443-761	127	45105-H7C-700A	154	45105-KN8-712	127
43957-80	553	45105-443-761	572	45105-H7C-700A	749	45105-KN8-712	572
43957-80A	553	45105-443-762	127	45105-HA2-671	104	45105-KR1-861	108

OE No.	SBS No.	OE No.	SBS No.	OE No.	SBS No.	OE No.	SBS No.
45105-KR1-861	588	45105-LEA7-305	654	45105-MW0-405	622	45106-MW3-671	181
45105-KR1-862	108	45105-LEE-8305	810	45105-MW0-415	622	45106-MW3-671	654
45105-KR1-862	588	45105-LEJ2-305	154	45105-MY6-405	694	45106-SB3-0001M1	163
45105-KR1-863	108	45105-LEJ2-305	749	45105-MY6-415	694	45106-SB3-0001M1	713
45105-KR1-863	588	45-105-LFC3-305	135	45105-N02-001-A	150	45106-SEA0000	119
45105-KR3-004	103	45-105-LFC3-305	546	45105-N02-001-A	745	45106-SEA0000	688
45105-KR3-004	551	45105-LFE9-305	945	45105-NF4-000	600	4510A-KFW6-900	119
45105-KR3-007	103	45105-LGE5-305	159	45105-NN2-900	105	4510A-KFW6-900	688
45105-KR3-007	551	45105-LGE5-305	761	45105-NN2-900	559	4510A-KW6-9000	119
45105-KR3-014	103	45105-LKF-305	214	45-105-NN3-830	802	4510A-KW6-9000	688
45105-KR3-014	551	45105-LKF-305	844	45105-NN4-K20	939	45110-B20T000	101
45105-KR3-601	103	45105-LLJ3-305	183	45105-NX7-006	782	45110-B20T000	544
45105-KR3-601	551	45105-LLJ3-305	627	45105-PWA-305	810	45110-HB7-007	592
45105-KR3-602	103	45105-MA5-671	526	45105-PWB-1305	822	45110-J00-P001	203
45105-KR3-602	551	45105-MA5-771	561	45105-SB3-0001M1	163	45110-J00-P001	585
45105-KR3-603	103	45105-MAS-772	561	45105-SB3-0001M1	713	45110-J4FT-000	141
45105-KR3-603	551	45105-MC7-004	127	45105-SE5-5001E	115	45110-J4FT-000	723
45105-KR3-871	119	45105-MC7-004	572	45105-SE5-5001E	670	45110-JHFT-000	101
45105-KR3-871	688	45105-MC7-007	127	45105-SE5R-00M4	115	45110-JHFT-000	544
45105-KS3-901	108	45105-MC7-007	572	45105-SE5R-00M4	670	45110-K2GP-000	163
45105-KS3-901	588	45105-MC7-014	127	45105-SEA0000	119	45110-K2GP-000	713
45105-KS3-902	108	45105-MC7-014	572	45105-SEA0000	688	45110P180000	983
45105-KS3-902	588	45105-MC7-024	127	45105-TFA-000-A	129	45110T740000	234
45105-KS5-004	104	45105-MC7-024	572	45105-TFA-000-A	710	45110T740000	968
45105-KS5-004	558	45105-MC9-305	561	45106-300-004	502	45110-T80-0000	232
45105-KS5-006	104	45105-MG3-006	104	45106-323-013	501	45110-T80-0000	961
45105-KS5-006	558	45105-MG3-006	558	45106-323-016	501	45112-GC4-601	100
45105-KS6-831A	139	45105-ML0-007	593	45106-323-023	501	45112-GC4-601	536
45105-KS6-831A	603	45105-ML4-000	593	45106-323-036	501	45112-GC4-601	592
45105-KT0-405	139	45105-ML4-004	593	45106-323-043	501	45112-GC4-831	100
45105-KT0-405	603	45105-ML4-006	593	45106-341-000	502	45112-GC4-831	536
45105-KT0-405	694	45105-ML4-008	593	45106-341-003	502	45112-GC4-831	592
45105-KT7-751	593	45105-ML4-014	593	45106-341-305	502	45112-GZ0-315	115
45105-KT7-761	593	45105-ML4-024	593	45106-390-003	501	45112-GZ0-315	670
45105-KT8-004	593	45105-ML7-006	600	45106-390-006	501	451-13-030-000	794
45105-KT0-405	694	45105-ML7-007	600	45106-390-305	501	45113-REA-300A	810
45105-KV0-701	647	45105-ML7-017	593	45106-BA5-RB10M1	181	4511A-RAI-000	810
45105-KV6-701	694	45105-ML7-405	183	45106-BA5-RB10M1	654	45120-107-000	111
45105-KW3-405	139	45105-ML7-405	627	45106-B08E00	141	45120-107-000	619
45105-KW3-405	603	45105-ML7-921/922	183	45106-B08E00	723	45120-119-00	101
45105-KW3-681	139	45105-ML7-921/922	627	45106-HA5-671B	139	45120-119-00	544
45105-KW3-681	603	45105-ML7-P10	183	45106-HA5-671B	603	45120-128-000	203
45105-KW6-405	119	45105-ML7-P10	627	45106-HA5-672B	139	45120-128-000	585
45105-KW6-405	688	45105-MM5-007	600	45106-HA5-672B	603	45120-1-68000	101
45105-KW7-405	103	45105-MM5-008	600	45106-KR3-871	119	45120-1-68000	544
45105-KW7-405	551	45105-MM5-017	600	45106-KR3-871	688	45120-1-69000	101
45105-KY4-901	108	45105-MM9-670	127	45106-KS6-701A	139	45120-1-69000	544
45105-KY4-901	588	45105-MM9-670	572	45106-KS6-701A	603	45120-211-000	135
45105-KY4-902	108	45105-MM9-781	127	45106-KS6-701B	139	45120-211-000	546
45105-KY4-902	588	45105-MM9-781	572	45106-KS6-701B	603	45120-256-000	810
45105-KY7-008	139	45105-MM9-782	127	45106-KS6-831B	139	45120-580-000	706
45105-KY7-008	603	45105-MM9-782	572	45106-KS6-831B	603	45120-J4A-T000	123
45105-KZ1-405	139	45105-MN4-007	593	45106-KV3-701	622	45120-J4A-T000	697
45105-KZ1-405	603	45105-MN4-008	593	45106-KV6-701	694	45120-J80-000	933
45105-KZ1-405	694	45105-MN5-008	647	45106-KW3-681	139	45120-T40-0000	119
45105-KZ1-405	694	45105-MN5-018	647	45106-KW3-681	603	45120-T40-0000	688
45105-LB17-3050	810	45105-MN8-006	622	45106-KY7-008	139	45120T-580000	163
45105-LBA2-305	183	45105-MN9-008	647	45106-KY7-008	603	45120T-580000	713
45105-LBA2-305	627	45105-MR1-671	647	45106-ML7-922	183	45130-L4A300	215
45105-LBA7-3050	810	45105-MR7-006	622	45106-ML7-922	627	45130-L4A300	893
45105-LCA7-305	183	45105-MR7-612	622	45106-ML7-922B	183	45130T40-000	163
45105-LCA7-305	627	45105-MR7-681	622	45106-ML7-922B	627	45130T40-000	713
45105-LDC8-305	163	45105-MS6-901	647	45106-MN8-67-1B	181	45135-L4A300	215
45105-LDC8-305	713	45105-MS8-008	647	45106-MN8-67-1B	654	45135-L4A300	893
45105-LDCS-305	154	45105-MS9-612	183	451-06-MR4-901	183	45150-KBK-9000-MZ	141
45105-LDCS-305	749	45105-MS9-612	627	451-06-MR4-901	627	45150-KBK-9000-MZ	723
45105-LEA-010A	140	45105-MT2-007	647	45106-MS9-612	183	45150-KEG8-3050	163
45105-LEA-010A	708	45105-MT2-008	647	45106-MS9-612	627	45150-KEG8-3050	713
45105-LEA1-306	163	45105-MT4-651/405	183	45106-MS9-612B	181	45150-LLB5-3050	119
45105-LEA1-306	713	45105-MT4-651/405	627	45106-MS9-612B	654	45150-LLB5-3050	688
45105-LEA7-305	183	45105-MT8-008	647	45106-MT4-651/405	183	451A0-HB5-670	592
45105-LEA7-305	627	45105-MV4-008	183	45106-MT4-651/405	627	451A0-HB9-670	139
45105-LEA7-305	181	45105-MV4-008	627	45106-MW3-671	647	451A0-HB9-670	603

OE No.	SBS No.	OE No.	SBS No.	OE No.	SBS No.	OE No.	SBS No.
451A0-KA3-731	104	494628	168	4FM-W0046-00	555	4XV-W0046-10	733
451A0-KA3-731	558	494628	774	4FU-W0045-00	170	50-005	678
451A0-KR3-603	103	494762	117	4FU-W0045-00	663	503-13-030-000	151
451A0-KR3-603	551	494762	680	4GA-W0045-00	128	503-13-030-000	671
451A0-MG3-670	104	494938	142	4GA-W0045-00	691	503-13-030-100	151
451A0-MG3-670	558	494938	724	4GV-F5911-00	151	503-13-030-100	671
451A0-MM8-670	160	494966	157	4GV-F5911-00	671	510	506
451A0-MM8-670	542	494966	730	4GV-FS811-00	175	510-015-4-282	105
451A0-MN4-670	593	497002	166	4GV-FS811-00	675	510-015-4-282	559
451A0-MT2-670	647	497002	772	4GV-FS811-00	648	510-362-4-282	132
451A0-MT4-670	183	497072	177	4GY-W0045-01	197	510-362-4-282	595
451A0-MT4-670	627	497072	786	4GY-W0045-01	611	513506	135
451A0-MT8-670	647	497083	157	4GY-W0046-00	648	513506	546
451A0-ML7-670	600	497083	730	4H7-W0045-00	545	514069	101
45340-107-720-A	525	497116	177	4H7-W0045-10	545	514069	544
45340-107-721-A	525	497116	786	4H7-W0045-12	545	515049	810
45340-107-722-A	525	497348	166	4HM-W0045-00	706	515050	810
45340-149-000-A	525	497348	772	4HM-W0045-00	128	5190-080256	103
45340-149-003-A	525	497394	157	4HM-W0045-00	691	5190-080256	551
45340-149-720-A	525	497394	730	4HM-W0045-50	706	51L-W0046-00	570
45340-950-000-A	525	497395	187	4JG-W0045-00	155	51L-W0046-01	570
45345-107-720-B	525	497395	818	4JG-W0045-00	728	51L-W0046-02	570
45345-107-721-B	525	497396	151	4K0-W0045-00	507	52R-W0045-00	550
45345-107-722-B	525	497396	671	4K0-W0045-01	507	52S-F5811-00	208
45345-149-000-B	525	497417	102	4K0-W0045-02	507	52S-F5811-00	876
45345-149-003-B	525	497417	548	4KG-W0045-00	590	53182-ABE1-9000	566
45345-149-720-B	525	497429	191	4KG-W045-10	706	54074--10000	100
45345-950-000-B	525	497429	831	4KL-F5811-00	107	54074--10000	536
45350-107-720	525	498408	123	4KL-F5811-00	575	545-13209-044	135
45350-107-720-B	525	498408	697	4KM-W0045-00	170	545-13209-044	546
45350-950-000	525	498414	117	4KM-W0045-00	663	546-13-209-044	151
45802-115-0000	816	498414	680	4KO-W0045-00	535	546-13-209-044	671
45815-NAF00	101	498454	123	4KO-W0045-10	535	546-13-309-200	175
45815-NAF00	544	498454	697	4L3-W0045-00	547	546-13-309-200	675
45815RAM00/01	101	498840	109	4L3-W0045-10	547	546-13-309-300	175
45815RAM00/01	544	498840	607	4LO-W0045-00	535	546-13-309-300	675
45815-RAM-000	135	498846	130	4LO-W0045-10	535	546-13-309-400	175
45815-RAM-000	546	498846	712	4MX-W0045-00	197	546-13-309-400	675
45815-RAM-01	914	498846	142	4MX-W0045-00	611	548-13-090-000	791
45815-RAM-01	135	498846	724	4NK-W0045-00	590	548-13-090-100	791
45815-RAM-01	546	4AJ-W0045-00	105	4NK-W0046-00	590	548-13-090-300	791
460-13-016-000	105	4AJ-W0045-00	559	4P1-W0045-00	136	55100-23044-08	100
460-13-016-000	559	4AP-W0046-00	570	4P1-W0045-00	589	55100-23044-08	536
460-13-090-000	106	4B5-25805-00	198	4PT-W0045-00	137	55120315	183
460-13-090-000	574	4B5-25805-00	634	4PT-W0045-00	650	55120315	627
46113030-000	783	4B5-W0045-00	198	4S5-W0045-00	227	55120-J41-000	152
462-13-030-000	783	4B5-W0045-00	634	4S5-W0045-00	858	55120-J41-000	747
464143	132	4BP-W0045-00	170	4SU-F5811-00	566	55120P-300000	157
464143	595	4BP-W0045-00	663	4SV-W0045-00	198	55120P-300000	730
464-20000-11	500	4C8-W0045-00	839	4SV-W0045-00	634	55W-W0045-00	596
464-20000-12	500	4C9-W0045-00	227	4SV-W0045-50	555	55W-W0045-01	596
46630-FYBQ-000	103	4C9-W0045-00	858	4TP-W0045-00	197	560584	163
46630-FYBQ-000	551	4CU-F5811-20	123	4TP-W0045-00	611	560584	713
46721-06	846	4CU-F5811-20	697	4TR-W0045-00	170	56325-R	151
470-13-030-000	885	4CU-W0045-00	123	4TR-W0045-00	663	56325-R	671
470-13-090-000	783	4CU-W0045-00	697	4TW-W0046-00	659	565-13209323	621
470-13-090-200	783	4D3-W0045-00	850	4US-W0045-00	155	565-13209544	621
470-13090-300	872	4D3-W0045-10	849	4US-W0045-00	728	56A-W0046-00	580
4716630	128	4DA-W0046-00	648	4VV-F5811-00	123	573-V3-030-000	566
4716630	691	4EB-W0045-00	128	4VV-F5811-00	697	585010100005	855
4722090	167	4EB-W0045-00	691	4W1-W0045-00	547	585925/A	176
4722090	773	4ES-W0045-00	136	4W1-W0045-20	547	585925/A	674
4730480	155	4ES-W0045-00	589	4W1-W0045-30	547	587-13-030-000	706
4730480	728	4ES-W0046-00	584	4W1-W0046-00	528	59100-01820	597
4741-537	523	4EW-W0045-00	197	4W5-W0045-00	545	59100-02820	101
47X-W0045-00	555	4EW-W0045-00	611	4WM-W0045-00	170	59100-02820	544
47X-W0045-01	555	4EW-W0045-01	197	4WM-W0045-00	663	59100-02821	101
48-7100-7	107	4EW-W0045-01	611	4WM-W0046-00	590	59100-02821	544
48-7100-7	575	4FM-W0045-00	683	4WV-W0045-00	592	59100-02830	101
491-13-409-044	138	4FM-W0045-10	683	4X8-W0045-00	550	59100-02830	544
491-13-409-044	519	4FM-W0045-10	555	4XV-W0045-00	198	59100-03860	706
494097	142	4FM-W0045-20	555	4XV-W0045-00	634	59100-04830	578
494097	724	4FM-W0045-30	555	4XV-W0046-00	733	59100-05820	119

OE No.	SBS No.	OE No.	SBS No.	OE No.	SBS No.	OE No.	SBS No.
59100-05820	688	59100-38820	577	59130-30B21	577	59300-27830	197
59100-05830	163	59100-38870	100	59130-32000	631	59300-27830	611
59100-05830	713	59100-38870	536	59130-32020	631	59300-27850	197
59100-06820	577	59100-38880	100	59130-32C00	631	59300-27850	611
59100-07810	119	59100-38880	536	59130-32C10	631	59300-27860	197
59100-07810	688	59100-39810	503	59130-32C20	631	59300-27860	611
59100-09840	134	59100-39850	197	59130-33C00	624	59300-29820	203
59100-09840	638	59100-39850	611	59130-33C10	624	59300-29820	585
59100-09840	197	59100-40810	624	59130-36A00	587	59300-29860	694
59100-09840	611	59100-40830	686	59130-36A01	587	59300-33810	135
59100-09850	197	59100-43810	591	59130-38C00	631	59300-33810	546
59100-09850	611	59100-45820	511	59130-40C00	624	59300-33850	705
59100-09860	134	59100-45821	511	59130-45230	533	59300-33870	686
59100-09860	638	59100-45860	597	59130-45C10	620	59300-33890	686
59100-09870	197	59100-46820	686	59130-46E00	686	59300-34830	631
59100-09870	611	59100-47890	806	59130-48B00	620	59300-35810	123
59100-09880	134	59101-03810	192	59300-03840	591	59300-35810	697
59100-09880	638	59101-03810	828	59300-03860	101	59300-36810	135
59100-09890	197	59101-03820	192	59300-03860	544	59300-36810	546
59100-09890	611	59101-03820	828	59300-03870	101	59300-36811	135
59100-10810	577	59101-09810	122	59300-03870	544	59300-36811	546
59100-11850	515	59101-09810	702	59300-03880	122	59300-36820	135
59100-14830	841	59101-14870	841	59300-03880	702	59300-36820	546
59100-14850	841	59101-26820	183	59300-03891	122	59300-36821	135
59100-14860	841	59101-26820	627	59300-03891	702	59300-36821	546
59100-16820	556	59101-33810	704	59300-04830	135	59300-36822	135
59100-18840	503	59101-33820	704	59300-04830	546	59300-36822	546
59100-18841	503	59101-33830	704	59300-04831	135	59300-36840	503
59100-19820	620	59101-33850	704	59300-04831	546	59300-36850	694
59100-20810	577	59101-35810	631	59300-05810	533	59300-36860	694
59100-20820	577	59101-38810	100	59300-06E00	105	59300-36870	694
59100-21860	183	59101-38810	536	59300-06E00	559	59300-36871	135
59100-21860	627	59101-38820	100	59300-08810	197	59300-36871	546
59100-21870	183	59101-38820	536	59300-08810	611	59300-37810	102
59100-21870	627	59101-38850	100	59300-09810	101	59300-37810	548
59100-21890	119	59101-38850	536	59300-09810	544	59300-39820	524
59100-21890	688	59101-38860	100	59300-09811	101	59300-39821	524
59100-22810	631	59101-38860	536	59300-09811	544	59300-39840	538
59100-22830	192	59102-33810	704	59300-09820	123	59300-3K880	694
59100-22830	828	59102-33840	704	59300-09820	697	59300-42810	100
59100-23830	782	59102-33870	704	59300-09840	134	59300-42810	536
59100-23840	782	59103-33810	704	59300-09840	638	59300-42840	666
59100-24810	620	59130-00810	577	59300-09850	134	59300-42850	100
59100-26810	597	59130-00A00	577	59300-09850	638	59300-42850	536
59100-29820	806	59130-00A10	577	59300-13830	694	59300-42850	592
59100-29840	806	59130-04A00	578	59300-13860	694	59300-42860	592
59100-29850	806	59130-04A10	578	59300-14830	582	59300-42870	592
59100-29860	806	59130-06B10	577	59300-17810	624	59300-44810	511
59100-30810	577	59130-06B20	577	59300-17811	624	59300-44820	511
59100-30820	577	59130-06C00	631	59300-18810	503	59300-44821	511
59100-31830	503	59130-16700	556	59300-20830	122	59300-44822	511
59100-31831	503	59130-16720	556	59300-20830	702	59300-44850	626
59100-31850	836	59130-16730	556	59300-20841	122	59300-44860	511
59100-31860	835	59130-16740	556	59300-20841	702	59300-44870	100
59100-32820	631	59130-16750	556	59300-20880	122	59300-44870	536
59100-33810	135	59130-16810	556	59300-20880	702	59300-45820	515
59100-33810	546	59130-17C00	624	59300-20890	122	59300-45890	511
59100-33812	135	59130-19C00	620	59300-20890	702	59300-45891	511
59100-33812	546	59130-20C00	620	59300-21820	183	59300-46810	516
59100-33820	135	59130-22D00	631	59300-21820	627	59300-46811	516
59100-33820	546	59130-24A00	577	59300-21840	183	59300-46820	516
59100-33830	624	59130-24A10	620	59300-21840	627	59300-46820	686
59100-33830	704	591-30-26820	135	59300-21850	183	59300-46840/830	686
59100-33850	704	591-30-26820	546	59300-21850	627	59300-47810	515
59100-33870	704	59130-26D00	620	59300-22830	192	59300-47820	515
59100-34820	515	59130-27A00	577	59300-22830	828	59300-47830	515
59100-34830	631	59130-27A10	577	59300-24830	581	59300-47840	515
59100-34880	951	59130-30B00	556	59300-26820	135	59300-47850	515
59100-35830	631	59130-30B00	577	59300-26820	546	59300-47870	515
59100-35850	631	59130-30B01	577	59300-26830	197	59300-47880	515
59100-35880	631	59130-30B10	556	59300-26830	611	59300-49820	534
59100-36830/1	503	59130-30B20	556	59300-27810	197	59300-49821	534
59100-36850	587	59130-30B21	556	59300-27810	611	59300-49850	534

OE No.	SBS No.	OE No.	SBS No.	OE No.	SBS No.	OE No.	SBS No.
59300-HG5-800	103	59401-HP7-600	688	5LP-W0046-50	592	5VK-W0046-00	175
59300-HG5-800	551	594-13-030-000	843	5LV-W0046-50	770	5VK-W0046-00	675
59301-03820	726	5943082-0123	704	5ME-F5919-00	123	5VN-W0045-00	198
59301-33810	135	59C-25806-00	169	5ME-F5919-00	697	5VN-W0045-00	634
59301-33810	546	59C-25806-00	768	5ME-FS811-00	123	5VU-W0046-01	185
59301-33820	705	5AP-W0045-00	183	5ME-FS811-00	697	5VU-W0046-01	812
59301-33830	705	5AP-W0045-00	627	5MF-F5811-00	123	5VX-25806-00	162
59301-33840	705	5AU-W0045-10	170	5MF-F5811-00	697	5VX-25806-00	657
59301-33870	686	5AU-W0045-10	663	5MV-W0045-00	694	5VX-W0045-00	128
59301-36810	694	5B4-W0045-00	134	5MV-W0046-00	144	5VX-W0045-00	691
59301-39810	135	5B4-W0045-00	638	5MV-W0046-00	604	5VX-W0045-00	162
59301-39810	546	5B4-W0045-10	197	5NR-F5811-00	151	5VX-W0045-00	657
59301-39811	135	5B4-W0045-10	611	5NR-F5811-00	157	5VX-W0046-00	162
59301-39811	546	5BK-F-5811-00	109	5NR-F5811-00	671	5VX-W0046-00	657
59301-39812	135	5BK-F-5811-00	607	5NR-F5811-00	730	5VY-W0045-00	198
59301-39812	546	5BN-W0045-00	170	5NR-F5811-10	157	5VY-W0045-00	634
59301-39841	203	5BN-W0045-00	663	5NR-F5811-10	730	5WX-W0045-00	168
59301-39841	585	5CG-W0046-00	155	5NW-W0045-00	190	5WX-W0045-00	774
59301-45810	533	5CG-W0046-00	728	5NW-W0045-00	823	5WX-W0045-10	105
59301-45811	533	5CG-W0046-20	155	5PA-W0045-00	136	5WX-W0045-10	559
59301-45850	533	5CG-W0046-20	728	5PA-W0045-00	589	5XC-W0045-00	840
59301-45860	597	5CH-F5911-00	151	5PA-W0046-00	584	5XT-W0045-00	155
59301-48811	183	5CH-F5911-00	671	5PS-W0046-00	769	5XT-W0045-00	728
59301-48811	627	5CP-W0045-00	111	5PW-W0046-50	155	5XT-W0046-50	632
59301-HP7-600	163	5CP-W0045-00	619	5PW-W0046-50	728	5YU-W0046-00	181
59301-HP7-600	713	5D7-F5805-00	214	5R2-W0045-00	550	5YU-W0046-00	654
59301-HP7-600	119	5D7-F5805-00	844	5RM-W0045-10	163	600-13-030-000	176
59301-HP7-600	688	5D7-F5911-00	810	5RM-W0045-10	713	600-13-030-000	674
59302-20820	102	5D7-FS811-00	151	5RM-W0045-10	197	603-13-130-000	706
59302-20820	548	5D7-FS811-00	671	5RM-W0045-10	611	6050-080180	163
59302-22850	705	5D9-W0045-01	227	5RU-W0045-00	128	6050-080180	713
59302-33810	705	5D9-W0045-01	858	5RU-W0045-00	691	605-08-02-50	107
59302-33830	705	5DH-W0045-00	694	5RU-W0046-00	185	605-08-02-50	575
59302-33850	705	5DH-W0045-10	694	5RU-W0046-00	812	606-08-02-70	157
59302-39870	524	5DH-WD0046-00	144	5RW-FS811-00	123	606-08-02-70	730
59302-45810	597	5DH-WD0046-00	604	5RW-FS811-00	697	610113-497417	101
59302-45830	511	5DS-F5811-00	151	5S7-10045-00	170	610113-497417	544
59303-33810	705	5DS-F5811-00	671	5S7-10045-00	663	610143	101
59312-HP7-600	633	5EB-W0046-00	155	5S7-25805-00	170	610143	544
59330-09EFO	123	5EB-W0046-00	728	5S7-25805-00	663	610164810	915
59330-09EFO	697	5EK-W0045-10	155	5S9-W0045-00	208	613-13-030-000	841
59330-35E00	123	5EK-W0045-10	728	5S9-W0045-00	876	61313090000	157
59330-35E00	697	5ET-W0046-00	144	5SE-F5811-00	151	61313090000	730
59330-38300	533	5ET-W0046-00	604	5SE-F5811-00	671	61321161A	1003
59330-38310	533	5GF-W0045-00	197	5SE-F5811-10	151	61321161A	151
59330-39100	524	5GF-W0045-00	611	5SE-F5811-10	671	61321161A	671
59330-46F00	101	5GF-W0046-00	648	5SL-25805-00	198	613-4-004-1-A	566
59330-46F00	544	5GH-W0046-00	196	5SL-25805-00	634	613-4-004-24	566
59330-49F00	151	5GH-W0046-00	754	5SL-W0045-00	198	6134005-1A	105
59330-49F00	671	5GH-W0046-10	196	5SL-W0045-00	634	6134005-1A	559
59330-H99-700	734	5GH-W0046-10	754	5SL-W0046-00	162	613-4007-71A	138
59340-13A00	100	5GJ-W0046-00	169	5SL-W0046-00	657	613-4007-71A	519
59340-13A00	536	5GJ-W0046-00	768	5SU-W0045-00	206	613-4008-1A	138
59340-14500	582	5GM-W0046-00	155	5SU-W0045-00	874	613-4008-1A	519
59340-14501	582	5GM-W0046-00	728	5SU-W0045-00	151	613-4-009-1A	566
59340-14510	582	5HH-W0045-00	163	5SU-W0045-00	671	61340121A	900
59340-14600	581	5HH-W0045-00	713	5SU-W0045-02	206	613-4-0201-A	706
59340-22A00	100	5HH-W0045-10	119	5SU-W0045-02	874	613-4-021-1A	157
59340-22A00	536	5HH-W0045-10	688	5TG-W0046-10	125	613-4-021-1A	730
59340-24B00	581	5JJ-W0045-00	198	5TG-W0046-10	709	613-4-0211-B	706
59340-24B10	581	5JJ-W0045-00	634	5UG-W0045-00	767	61340-281A	138
59340-39100	524	5JU-W0045-00	111	5UG-W0046-00	816	61340-281A	519
59340-42A10	100	5JU-W0045-00	619	5UN-W0046-00	790	61340-311A	138
59340-42A10	536	5JW-W0046-00	769	5UN-W0046-50	790	61340-311A	519
59340-44A00	100	5KE-W0045-00	782	5UN-W0046-51	790	613-403-81A	157
59340-44A00	536	5KM-W0046-00	799	5V6-W0045-00	576	613-403-81A	730
59340-46F00	101	5KN-W0045-00	165	5V6-W0045-01	576	613-4-038-1A	157
59340-46F00	544	5KN-W0045-00	764	5VB-W0045-00	113	613-4-038-1A	730
59400-HP7-600	633	5LB-W0045-00	155	5VB-W0045-00	651	613-4-0411-A	706
59401-HP7-600	633	5LB-W0045-00	728	5VB-W0045-00	118	613-4-0541A	138
59401-HP7-600	163	5LP-W0045-00	100	5VB-W0045-00	684	613-4-0541A	519
59401-HP7-600	713	5LP-W0045-00	536	5VK-W0045-00	176	61340721A	151
59401-HP7-600	119	5LP-W0046-00	592	5VK-W0045-00	674	61340721A	671

OE No.	SBS No.	OE No.	SBS No.	OE No.	SBS No.	OE No.	SBS No.
6134-072-1A	151	690-13-090-000	730	69100-36850	144	69130-48B00	577
6134-072-1A	671	690-13-190-000	157	69100-36850	604	69130-49F00	157
61340731A	138	690-13-190-000	730	69100-36860	144	69130-49F00	730
61340731A	519	69095	144	69100-36860	604	69140-03D00	632
61340751A	176	69095	604	69100-36870	144	69140-05D00	648
61340751A	674	69096	144	69100-36870	604	69140-15D00	632
61340791A	841	69096	604	69100-37810	144	69140-19A00	592
61340901A	841	69096-05	790	69100-37810	604	69140-19A01	592
61340941A	176	69100-01810	649	69100-37830	144	69140-19A10	592
61340941A	674	69100-01810	886	69100-37830	604	69140-19A11	592
61340951A	157	69100-01880	886	69100-38810	577	69140-26C00	584
61340951A	730	69100-02821	101	69100-38820	577	69140-26C00	648
61340961A	841	69100-02821	544	69100-38840	577	69140-27C10	648
61341021A	900	69100-03840	767	69100-38860	577	69140-27C20	648
61341101A	841	69100-03880	820	69100-38870	577	69140-28C00	632
61341231A	841	69100-03890	196	69100-40820	715	69140-35B00	649
61654630	506	69100-03890	754	69100-40840	715	69140-43840	648
6211	802	69100-04830	161	69100-43820	648	69140-43B00	649
639-41-054	699	69100-04830	614	69100-43840	648	69140-43B10	649
64098800	111	69100-05830	556	69100-43850	648	69140-43D00	648
64098800	619	69100-05860	556	69100-44860	635	69301-H08-100	152
647073	142	69100-05870	556	69100-45890	620	69301-H08-100	747
647073	724	69100-05890	556	69100-47820	834	69400-37820	144
647074	151	69100-06810	556	69100-47830	834	69400-37820	604
647074	671	69100-06820	162	69100-48810	577	7-020-016	134
647077	157	69100-06820	657	69100-48820	881	7-020-016	638
647077	730	69100-06830	162	69101-03810	196	7-020-022	848
647078	177	69100-06830	657	69101-03810	754	7030-081420	197
647078	786	69100-07810	649	69101-03820	835	7030-081420	611
647079	187	69100-08850	162	69101-05820	556	7030-081520	135
647079	818	69100-08850	657	69101-44810	833	7030-081520	546
647080	191	69100-08860	162	69101-44850	881	7030-0853A0	134
647080	831	69100-08860	657	69101-44890	833	7030-0853A0	638
647157	142	69100-0BE00	556	69101-45820	512	7030-0855A0	135
647157	724	69100-10820	789	69101-45830	512	7030-0855A0	546
647161	166	69100-10840	182	69101-45840	512	7040	803
647161	772	69100-10840	804	69101-45850-XNA	512	705-600-004	767
647170	142	69100-10860	182	69101-45860-XNA	512	705-600-014	196
647170	724	69100-10860	804	69102-05890	182	705-600-014	754
647171	102	69100-12810	635	69102-05890	804	705-600-150	767
647171	548	69100-14860	174	69107	151	705-600-285	101
647172	123	69100-14860	781	69107	671	705-600-285	544
647172	697	69100-14890	174	69116	151	705-600-349	196
647176	117	69100-14890	781	69116	671	705-600-349	754
647176	680	69100-15810	632	69130-16700	556	705-600-350	767
647400	191	69100-15830	833	69130-16740	556	705-600-398	196
647400	831	69100-15850	833	69130-20A10	556	705-600-398	754
650983	177	69100-16851	162	69130-21820	556	705600485	908
650983	786	69100-16851	657	69130-21E00	556	705600-711	908
651253	177	69100-16852	162	69130-26D00	620	705601014	910
651253	786	69100-16852	657	69130-27A10	556	705601015	911
651356	142	69100-18810	715	69130-30B21	556	705601149	971
651356	724	69100-20810	556	69130-31E00	701	705601150	972
665621	142	69100-21820	556	69130-33C00	556	705601150	134
665621	724	69100-22820	615	69130-34220	512	705601150	638
665842	187	69100-22830	615	69130-34240	512	715500325	134
665842	818	69100-22850	615	69130-34C00	620	715500325	638
666397	152	69100-26810	620	69130-34C00	556	715500336	197
666397	747	69100-28820	790	69130-38820	577	715500336	611
666574	142	69100-29810	715	69130-38B00	577	71550036	197
666574	724	69100-31820	633	69130-38B10	577	71550036	611
666935	159	69100-31830	701	69130-45000	512	71550335	134
666935	761	69100-34860	620	69130-45001	512	71550335	638
668017	177	69100-34860	556	69130-45010	512	715900379	957
668017	786	69100-34870	512	69130-45020	512	715900380	956
668021	187	6910034890	915	69130-45021	512	715900386	957
668021	818	69100-35810	790	69130-45030	512	715900387	956
67131-5EE0-0000	101	69100-36820	144	69130-45100	512	736502	101
67131-5EE0-0000	544	69100-36820	604	69130-45101	512	736502	544
67131-BCA0-0000	134	69100-36830	144	69130-45990	512	737786	105
67131-BCA0-0000	638	69100-36830	604	69130-45C00	620	737786	559
690-13-030-000	841	69100-36840	144	69130-45C10	620	745658	167
690-13-090-000	157	69100-36840	604	69130-48810	577	745658	773

OE No.	SBS No.	OE No.	SBS No.	OE No.	SBS No.	OE No.	SBS No.
750-13-030-000	706	8000-68794	118	811-3016	138	8133516	151
75013090000	175	8000-68794	684	811-3016	519	8133516	671
75013090000	675	800070854	100	811-3064	138	8133539	152
750-13-090-000	175	800070854	536	811-3064	519	8133539	747
750-13-090-000	675	800070854	592	8113104	106	8133540	108
752071	116	800070858	197	8113104	574	8133540	588
752071	673	800070858	611	811-3118	138	8133542	157
752391	116	800070888	197	811-3118	519	8133542	730
752391	673	800070888	611	8113181	105	8133614	706
752394	116	800071450	197	8113181	559	8133724	108
752394	673	800071450	611	811-3196	138	8133724	588
752426	101	800071451	592	811-3196	519	8133725	108
752426	544	800074181	151	811-3222	138	8133725	588
752667	123	800074181	671	811-3222	519	8133726	152
752667	697	800078331	566	811-3283	641	8133726	747
752816	105	8000-78331	566	811-3323	138	8133761	159
752816	559	800079072	175	811-3323	519	8133761	761
752817	109	800079072	675	81133603	159	8133798	108
752817	607	800081593	706	81133603	761	8133798	588
752818	101	8000-82748	763	8113373	148	8133815	159
752818	544	800086714	841	8113373	652	8133815	761
753092	105	800086714	706	811-3375	113	8133906	176
753092	559	8000-88482	151	811-3375	651	8133906	674
753200	105	8000-88482	671	8113431	108	8133943	214
753200	559	8000-88482	183	8113431	588	8133943	844
754605	168	8000-88482	627	8113478	168	8133946	152
754605	774	800088725	108	8113478	774	8133946	747
754804	161	800088725	588	8113478	148	8213051	106
754804	614	8000-88725	108	8113478	652	8213051	574
754808	147	8000-88725	588	8113489	601	8213104	106
754808	722	8000-88772	706	8113523	168	8213104	574
755981-1160	167	800089025	900	8113523	774	8213-145	109
755981-1160	773	8000-901-56	138	8113533	176	8213-145	607
7-5-601-147	767	8000-901-56	519	8113533	674	821-3145	109
756020	168	800094024	676	8113538	175	821-3145	607
756020	774	800094411	566	8113538	675	821-3192	123
757215	105	8000-95280	157	8113585	566	821-3192	697
757215	559	8000-95280	730	8113593	151	821-3197	138
7588626	167	8000-95542	706	8113593	671	821-3197	519
7588626	773	80009634	151	8113595	118	821-3200	138
76513030000	175	80009634	671	8113595	684	821-3200	519
76513030000	675	80009870	676	8113604	148	821-3223	123
770-13-020-000	151	8000A2790	791	8113604	652	821-3223	697
770-13-020-000	671	8000A7143	151	8113627	176	821-3245	123
777-13-030-000	151	8000A7143	671	8113627	674	821-3245	697
777-13-030-000	671	8000A9231	175	811-3638	138	821-3246	123
786764	219	8000A9231	675	811-3638	519	821-3246	697
786764	716	8000B1421	805	811-3638	123	8213460	153
8000-29070	138	8000B1601	841	811-3638	697	8213460	748
8000-29070	519	8000B1663	841	811-3644	123	8213462	153
8000-33545	106	8000B5975	157	811-3644	697	8213462	748
8000-33545	574	8000B5975	730	811-3651	138	8213506	152
8000-37009	106	8000H4667	794	811-3651	519	8213506	747
8000-37009	574	8000H7132	783	811-3662	138	821-3571	123
8000-39730	138	8000H7138	872	811-3662	519	821-3571	697
8000-39730	519	802-567-1000	111	811-3663	123	8213577	152
8000-40413	106	802-567-1000	619	811-3663	697	8213577	747
8000-40413	574	803.08.01.60	170	8113720	706	821-3590	123
8000-45453	594	803.08.01.60	663	8113751	157	821-3590	697
8000-46147	138	803138	219	8113751	730	821-3638	123
8000-46147	519	803138	716	8113754	706	821-3638	697
8000-461-47	138	8044220	189	8113865	108	8213648	159
8000-461-47	519	8044220	821	8113865	588	8213648	761
8000-59214	641	8044221	203	811-3869	152	830-13-030-100	866
800059869	108	8044221	585	811-3869	747	830-13-090-100	867
800059869	588	8044601	900	8113898	157	83911-09B	904
8000-60195	692	810183	134	8113898	730	8532279	176
8000-66785	633	810183	638	8113988	176	8532279	674
8000-66796	647	8103662	138	8113988	674	8537246	706
800066937	126	8103662	519	812111	201	8537251	841
800066937	672	810K0209	803	812111	847	8538735	841
800067127	117	810K5804	189	812732	105	860883	151
800067127	680	810K5804	821	812732	559	860883	671



OE No.	SBS No.	OE No.	SBS No.	OE No.	SBS No.	OE No.	SBS No.
861760	157	903-08-08-80	134	CP6688D29	805	K01309079	168
861760	730	903-08-08-80	638	D06-45230-00-00	105	K01309079	774
862489	157	903-08-08-80	197	D06-45230-00-00	559	K01310073	203
862489	730	903-08-08-80	611	EJ29099074	105	K01310073	585
862698	157	903-08-08-90	134	EJ29099074	559	K4308-0006	790
862698	730	903-08-08-90	638	F000P02030	151	K4308-211-96	726
862900	167	9060-080810	134	F000P02030	671	K4308-21203	704
862900	773	9060-080810	638	FZ10176	810	K4308-21204	135
864121	203	9060-080910	197	G71315EE00000	101	K4308-21204	546
864121	585	9060-080910	611	G71315EE00000	544	K4308-21205	592
864342	228	9100788	694	G7131-LRA0-000	201	K4308-21225	694
864342	859	9100797	790	G7131-LRA0-000	847	K4308-21241	100
864428	203	99-2769	523	GA023463-1T	141	K4308-21241	536
864428	585	A000-0801A0	705	GA023463-1T	723	K4308-21242	752
864580	189	A000-0801B0	704	GA121001T	105	K4308-21274	686
864580	821	A000-0802B0	687	GA121001T	559	K4308-21286	694
865527	228	A45120-168-000	633	GF5359902	101	KA3495506	107
865527	859	AB024	151	GF5359902	544	KA3495506	575
866687	189	AB024	671	GU01654630	706	KA3496535	138
866687	821	AB024-S	151	GU03654600	176	KA3496535	519
866692	203	AB024-S	671	GU03654600	674	KA3497506	113
866692	585	AB040	175	GU05654630	151	KA3497506	651
883673	706	AB040	675	GU05654630	671	KA3497506	105
8900239	178	AB040-S	175	GU27654610	138	KA3497506	559
8900239	792	AB040-S	675	GU27654610	519	KM0961320	803
8900539	154	ABH-W0045-01	682	GU30654600	566	M028Z04	711
8900539	749	AM140607	912	GU30654602	566	M049Z04	805
890304	135	AP8113627	176	GU30654626	176	M1300001500	157
890304	546	AP8113627	674	GU30654626	674	M1300001500	730
894047	151	B044201	566	GU30654630	641	M13400001400	706
894047	671	B044202	566	GU30654631	601	M13400004400	157
894051	203	B044223	101	GU30654675	151	M13400004400	730
894051	585	B044223	544	GU30654675	671	M1340001400	176
897118	214	B044224	101	GU31654681	157	M1340001400	674
897118	844	B044224	544	GU31654681	730	M497Z04	841
8A00-461-47	138	B22-45230-0000	157	GU32654610	706	M9467Z04	151
8A00-461-47	519	B22-45230-0000	730	GV18654660	554	M9467Z04	671
8A0074181	151	B23-45280-0000	152	H0300-2AB	795	N50025061	566
8A0074181	671	B23-45280-0000	747	H0300F	676	P00-927-020-64-07-000	148
8A0079072	175	B29-25805-00	840	H0300T	181	P00-927-020-64-07-000	652
8A0079072	675	B2W-25805-00	965	H0300T	654	P150442	105
8B0074181	151	B54033-10000	855	H0300-T	183	P150442	559
8B0074181	671	B5H-25805-00-00	979	H0300-T	627	P4064905001002640	103
8C0074181	151	B5H-25806-00-00	980	H0301-T	161	P4064905001002640	551
8C0074181	671	B74074-100000	848	H0301-T	614	P67660000116700	103
9010-080510	799	B840C34	210	IC000760	228	P67660000116700	551
9010-0805A0	799	B840C34	878	IC000760	859	PE-745658	167
9010-0805B0	799	B840F64-6500000	810	IC000818	224	PE-745658	773
9010-0808B0	914	B840F6600000	717	IC000818	938	PE756676	142
901-08-03-22	717	BAS-25806-00	584	IC3-W0046-10	790	PE756676	724
901-08-05-01	799	BC-2500-22065	694	IC3-W0046-50	790	PE757231	168
901-08-05-10	799	BD5-25806-00	991	ID9-W0046-00	196	PE757231	774
901-08-08-01	914	BE250022065	694	ID9-W0046-00	754	PE757243	142
901-08-08-10	914	BE-2500-22065	694	IS3-W0045-00	197	PE757243	724
901-13-030-000	231	BE2500-22068	144	IS3-W0045-00	611	PE-758935	163
901-13-030-000	877	BE2500-22068	604	IS3-W0046-10	134	PE-758935	713
9021035000	138	BE250122065SM	566	IS3-W0046-10	638	PE-759057	123
9021035000	519	BE-675002509	790	ISC-F5805-00	101	PE-759057	697
9021038000	138	BQ300222065	151	ISC-F5805-00	544	PE774896	100
9021038000	519	BQ300222065	671	ISR29-002	655	PE774896	536
90210-55000	566	BQ300222068	151	K00946315	608	PE776-170	103
90214-01000	601	BQ300222068	671	K009463415	653	PE776-170	551
9022001000	681	BT-27922065	815	K00976315	168	PE776171	157
902203-100	118	BT-280022065	815	K00976315	774	PE776171	730
902203-100	684	BT280222068	803	K00976315	151	PE801968	140
902-300-1000	119	BT-6000063012	885	K00976315	671	PE801968	708
902-300-1000	688	BT62500GG	963	K00979315	928	PE-802219	142
902-3002000	163	BT65003013	939	K00996315	105	PE-802219	724
902-3002000	713	C389	802	K00996315	559	PE-802275	163
9024020000	624	C390	803	K01303070	167	PE-802275	713
9024030000	715	C-4721834	117	K01303070	773	PE802452	101
903-08-08-70	197	C-4721834	680	K01306075	220	PE802452	544
903-08-08-70	611	CP42264	719	K01306075	777	PE802576	119

OE No.	SBS No.	OE No.	SBS No.	OE No.	SBS No.	OE No.	SBS No.
PE802576	688	T-2020072-T301	638				
PE8033443	205	T2020077	181				
PE8033443	873	T2020077	654				
PE803444	135	T2020193	624				
PE803444	546	T2020194	181				
PS-2012-02001	101	T2020194	654				
PS-2012-02001	544	T2020211	683				
QCA0648860000	123	T2020218	683				
QCA0648860000	697	T2020221	683				
QCA0648860010	101	T2020245	624				
QCA0648860010	544	T2020246	624				
R0200710080	141	T-2020-329	782				
R0200710080	723	T2020393	624				
R050371008000	168	T-2020-475	782				
R050371008000	774	T2020537	181				
R050372080000	152	T2020537	654				
R050372080000	747	T2020543	183				
R051	105	T2020543	627				
R051	559	T2020553	624				
R1700-7208-0000	163	T2020602	162				
R1700-7208-0000	713	T2020602	657				
R180100127000	157	T2020602	161				
R180100127000	730	T2020602	614				
R235000	105	T2020692	176				
R235000	559	T2020692	674				
R290063110000	168	T2020848	176				
R290063110000	774	T2020848	674				
R30000126000	706	T2021221	864				
R351	148	T2021451	841				
R351	652	T2021541	841				
R434-2009-1A0	123	T2022475	163				
R434-2009-1A0	697	T2022475	713				
R434-2021-1-A0	123	T2025016	161				
R434-2021-1-A0	697	T2025016	614				
R43440-311A0	168	T2025045	163				
R43440-311A0	774	T2025045	713				
R444-2004-1-A0	123	T2027535	183				
R444-2004-1-A0	697	T2027535	627				
R44422001A	157	T2027545	183				
R44422001A	730	T2027545	627				
R44440-161A0	152	T2027820	841				
R44440-161A0	747	VGA-12182	908				
R44440181A0	166	VGA-12183	908				
R44440181A0	772	Y00-FA0112	115				
R800277	101	Y00-FA0112	670				
R800277	544	Y00FA1409	140				
R800278	163	Y00FA1409	708				
R800278	713	Z150-9261	908				
R050371008000	163						
R050371008000	713						
S10B-40202-00-00	803						
S11D-40202-00	167						
S11D-40202-00	773						
S4311-ARCA000	810						
S4511-ARCA000	810						
SBR-F5811-00	145						
SBR-F5811-00	731						
SBR-FS811-10	145						
SBR-FS811-10	731						
SEA-W0046-50	733						
SFL-W0046-50	733						
SGR-W0046-00	144						
SGR-W0046-00	604						
SM-27300	843						
SVH-W0045-00	128						
SVH-W0045-00	691						
SVU-W0045-10	128						
SVU-W0045-10	691						
T01H000101	111						
T01H000101	619						
T-2020071-T301	197						
T-2020071-T301	611						
T-2020072-T301	134						

# **BRAKE PINS**

## **FITMENTS, DRAWINGS**



Complete  
set



HONDA			Complete set		
CR	125 R	98 - 01	4000	4506	4505
CR	125 R	02 - 07	4001	4506	4508
CR	250 R	95 - 01	4000	4506	4505
CR	250 R	02 - 07	4001	4506	4508
CRF	250 R	04 - 20	4001	4506	4508
CRF	250 X	04 - 14	4001	4506	4508
CRF	450 R	02 - 18	4001	4506	4508
CRF	450 RX	17 - 18	4001	4506	4508
CRF	450 X	05 - 18	4001	4506	4508
HUSQVARNA					
CR	125	05 - 13	4003	4507	4510
TC	125	14 - 18	4003	4507	4510
TE	125	14 - 16	4003	4507	4510
TX	125	17 - 18	4003	4507	4510
CR	250	05 - 05	4003	4507	4510
FC	250	14 - 18	4003	4507	4510
FE	250	14 - 18	4003	4507	4510
TC	250	04 - 18	4003	4507	4510
TE	250	02 - 18	4003	4507	4510
TE	300	14 - 18	4003	4507	4510
FC	350	14 - 18	4003	4507	4510
FE	350	14 - 18	4003	4507	4510
TC	449	11 - 13	4003	4507	4510
FC	450	14 - 18	4003	4507	4510
FE	450	14 - 18	4003	4507	4510
TE	450	14 - 14	4003	4507	4510
FE	501	14 - 18	4003	4507	4510
TE	511	11 - 13	4003	4507	4510
KAWASAKI					
KX	125	95 - 96	4000	4506	4505
KX	125	97 - 08	4002	4509	4505
KX	250	95 - 96	4000	4506	4505
KX	250	97 - 08	4002	4509	4505
KX	250 F	04 - 18	4002	4509	4505
KX	450 F	06 - 18	4002	4509	4505
KTM					
EXC	125 Enduro	04 - 15	4003	4507	4510
SX	125	00 - 18	4003	4507	4510
SX	144	07 - 08	4003	4507	4510
SX	150	09 - 18	4003	4507	4510
EXC	200 Enduro	04 - 16	4003	4507	4510
SX	200	03 - 04	4003	4507	4510
EXC	250 Enduro	04 - 08	4003	4507	4510
EXC	250 Enduro 4T	04 - 06	4003	4507	4510
EXC	250 TPI	18 - 18	4003	4507	4510
EXC-F	250	07 - 18	4003	4507	4510
SX	250	03 - 18	4003	4507	4510
SX-F	250	06 - 18	4003	4507	4510
XC	250	06 - 14	4003	4507	4510
EXC	300 Enduro	04 - 08	4003	4507	4510
EXC	300 TPI	18 - 18	4003	4507	4510
XC	300	06 - 14	4003	4507	4510
EXC-F	350	11 - 18	4003	4507	4510
SX-F	350	11 - 18	4003	4507	4510
XC-F	350	12 - 19	4003	4507	4510
EXC	400 Racing	00 - 07	4003	4507	4510
SX	400	00 - 02	4003	4507	4510
EXC-F	450	04 - 18	4003	4507	4510
SX-F	450	03 - 24	4003	4507	4510
XC-F	450	06 - 19	4003	4507	4510
EXC-F	500	12 - 18	4003	4507	4510
XC-F	505	08 - 09	4003	4507	4510
EXC	520 Racing	00 - 02	4003	4507	4510
SX-F	520	00 - 02	4003	4507	4510
EXC	525 Racing	03 - 06	4003	4507	4510
SX-F	525	03 - 06	4003	4507	4510
XC-F	525	07 - 07	4003	4507	4510
EXC	530 Racing	08 - 11	4003	4507	4510



## SBS 4000



<b>HONDA</b>					
CR	125 R	98 - 01	•		
CR	250 R	95 - 01	•		
<b>KAWASAKI</b>					
KX	125	95 - 96	•		
KX	250	95 - 96	•		
<b>SUZUKI</b>					
RM	125	99 - 04	•		
RM	250	99 - 04	•		
RM-Z	250	07 - 07	•		
RM-Z	450	05 - 07	•		
<b>YAMAHA</b>					
YZ	85	10 - 19	•		
YZ	125	98 - 18	•		
WR	250 F	03 - 13	•		
YZ	250	98 - 18	•		
YZ	250 F	01 - 18	•		
YZ	250 FX	15 - 15	•		
YZ	400 F	98 - 98	•		
YZ	426 F	00 - 02	•		
WR	450 F	03 - 18	•		
YZ	450 F	03 - 09	•		

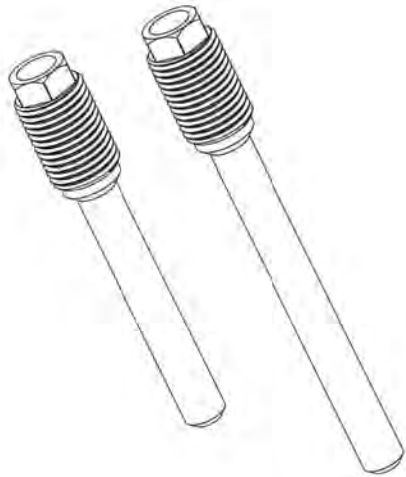

## SBS 4001



<b>HONDA</b>					
CR	125 R	02 - 07	•		
CR	250 R	02 - 07	•		
CRF	250 R	04 - 20	•		
CRF	250 X	04 - 14	•		
CRF	450 R	02 - 18	•		
CRF	450 RX	17 - 18	•		
CRF	450 X	05 - 18	•		
<b>SUZUKI</b>					
RM	125	05 - 09	•		
RM	250	05 - 09	•		
RM-Z	250	08 - 18	•		
RM-Z	450	08 - 18	•		



## SBS 4002



SBS 4509



SBS 4505



<b>KAWASAKI</b>					
KX	125	97 - 08	•		
KX	250	97 - 08	•		
KX	250 F	04 - 18	•		
KX	450 F	06 - 18	•		
<b>SUZUKI</b>					
RM-Z	250	04 - 06	•		

## SBS 4003



SBS 4507



SBS 4510

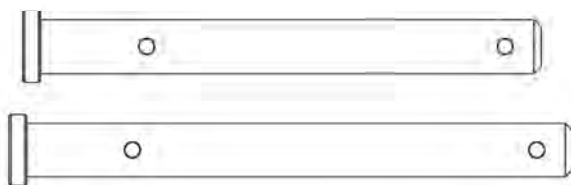

<b>HUSQVARNA</b>					
CR	125	05 - 13	•		
TC	125	14 - 18	•		
TE	125	14 - 16	•		
TX	125	17 - 18	•		
CR	250	05 - 05	•		
FC	250	14 - 18	•		
FE	250	14 - 18	•		
TC	250	04 - 18	•		
TE	250	02 - 18	•		
TE	300	14 - 18	•		
FC	350	14 - 18	•		
FE	350	14 - 18	•		
TC	449	11 - 13	•		
FC	450	14 - 18	•		
FE	450	14 - 18	•		
TE	450	14 - 14	•		
FE	501	14 - 18	•		
TE	511	11 - 13	•		
<b>KTM</b>					
EXC	125 Enduro	04 - 15	•		
SX	125	00 - 18	•		
SX	144	07 - 08	•		
SX	150	09 - 18	•		
EXC	200 Enduro	04 - 16	•		
SX	200	03 - 04	•		
EXC	250 Enduro	04 - 08	•		
EXC	250 Enduro 4T	04 - 06	•		
EXC	250 TPI	18 - 18	•		
EXC-F	250	07 - 18	•		
SX	250	03 - 18	•		
SX-F	250	06 - 18	•		
XC	250	06 - 14	•		
EXC	300 Enduro	04 - 08	•		
EXC	300 TPI	18 - 18	•		
XC	300	06 - 14	•		
EXC-F	350	11 - 18	•		
SX-F	350	11 - 18	•		
XC-F	350	12 - 19	•		
EXC	400 Racing	00 - 07	•		
SX	400	00 - 02	•		
EXC-F	450	04 - 18	•		
SX-F	450	03 - 24	•		
XC-F	450	06 - 19	•		

## SBS 4003



<b>KTM</b>				
EXC-F	500	12 - 18	•	
XC-F	505	08 - 09	•	
EXC	520 Racing	00 - 02	•	
SX-F	520	00 - 02	•	
EXC	525 Racing	03 - 06	•	
SX-F	525	03 - 06	•	
XC-F	525	07 - 07	•	
EXC	530 Racing	08 - 11	•	

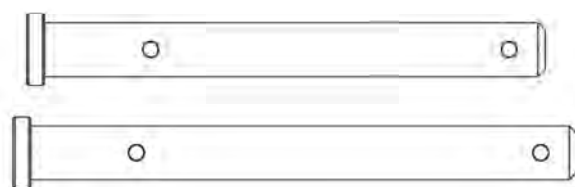

## SBS 4004



<b>YAMAHA</b>				
WR	250 F Efi	17 - 18	•	
WR	250 F Enduro GP	18 - 18	•	
WR	250 X	08 - 16	•	

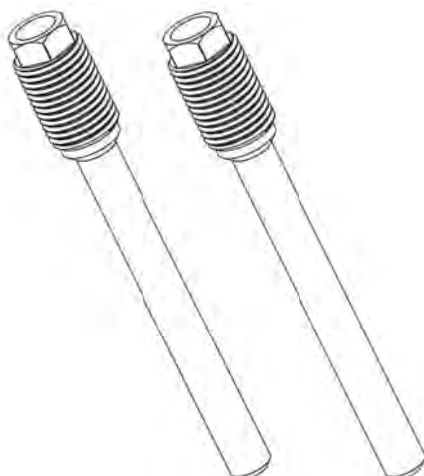



## SBS 4505

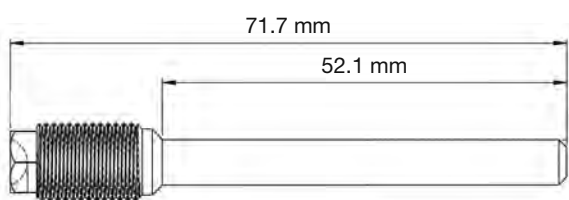

			Honda	Kawasaki	Suzuki
<b>HONDA</b>					
CR	125 R	98 - 01			•
CR	250 R	95 - 01			•
<b>KAWASAKI</b>					
KX	125	95 - 96			•
KX	125	97 - 08			•
KX	250	95 - 96			•
KX	250	97 - 08			•
KX	250 F	04 - 18			•
KX	450 F	06 - 18			•
<b>SUZUKI</b>					
RM	125	99 - 04			•
RM	250	99 - 04			•
RM-Z	250	04 - 06			•
RM-Z	250	07 - 07			•
RM-Z	450	05 - 07			•
<b>YAMAHA</b>					
YZ	85	10 - 19			•
YZ	125	98 - 18			•
WR	250 F	03 - 13			•
WR	250 F Efi	17 - 18		•	•
WR	250 F Enduro GP	18 - 18		•	•
WR	250 X	08 - 16		•	•
YZ	250	98 - 18			•
YZ	250 F	01 - 18			•
YZ	250 FX	15 - 15			•
YZ	400 F	98 - 98			•
YZ	426 F	00 - 02			•
WR	450 F	03 - 18			•
YZ	450 F	03 - 09			•

## SBS 4506

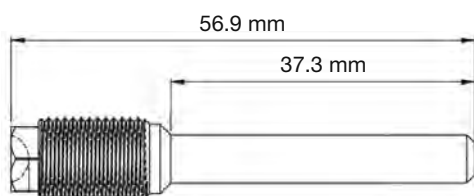

			Honda	Kawasaki	Suzuki
<b>HONDA</b>					
CR	125 R	98 - 01			•
CR	125 R	02 - 07			•
CR	250 R	95 - 01			•
CR	250 R	02 - 07			•
CRF	250 R	04 - 20			•
CRF	250 X	04 - 14			•
CRF	450 R	02 - 18			•
CRF	450 RX	17 - 18			•
CRF	450 X	05 - 18			•
<b>KAWASAKI</b>					
KX	125	95 - 96			•
KX	250	95 - 96			•
<b>SUZUKI</b>					
RM	125	99 - 04			•
RM	125	05 - 09			•
RM	250	99 - 04			•

## SBS 4506



SUZUKI				
RM	250	05 - 09	•	
RM-Z	250	07 - 07	•	
RM-Z	250	08 - 18	•	
RM-Z	450	05 - 07	•	
RM-Z	450	08 - 18	•	
YAMAHA				
YZ	85	10 - 19	•	
YZ	125	98 - 18	•	
WR	250 F	03 - 13	•	
YZ	250	98 - 18	•	
YZ	250 F	01 - 18	•	
YZ	250 FX	15 - 15	•	
YZ	400 F	98 - 98	•	
YZ	426 F	00 - 02	•	
WR	450 F	03 - 18	•	
YZ	450 F	03 - 09	•	

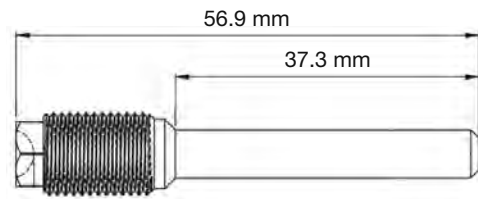

## SBS 4507



HUSQVARNA				
CR	125	05 - 13	•	
TC	125	14 - 18	•	
TE	125	14 - 16	•	
TX	125	17 - 18	•	
CR	250	05 - 05	•	
FC	250	14 - 18	•	
FE	250	14 - 18	•	
TC	250	04 - 18	•	
TE	250	02 - 18	•	
TE	300	14 - 18	•	
FC	350	14 - 18	•	
FE	350	14 - 18	•	
TC	449	11 - 13	•	
FC	450	14 - 18	•	
FE	450	14 - 18	•	
TE	450	14 - 14	•	
FE	501	14 - 18	•	
TE	511	11 - 13	•	
KTM				
EXC	125 Enduro	04 - 15	•	
SX	125	00 - 18	•	
SX	144	07 - 08	•	
SX	150	09 - 18	•	
EXC	200 Enduro	04 - 16	•	
SX	200	03 - 04	•	
EXC	250 Enduro	04 - 08	•	
EXC	250 Enduro 4T	04 - 06	•	
EXC	250 TPI	18 - 18	•	
EXC-F	250	07 - 18	•	
SX	250	03 - 18	•	
SX-F	250	06 - 18	•	
XC	250	06 - 14	•	
EXC	300 Enduro	04 - 08	•	
EXC	300 TPI	18 - 18	•	
XC	300	06 - 14	•	
EXC-F	350	11 - 18	•	
SX-F	350	11 - 18	•	
XC-F	350	12 - 19	•	
EXC	400 Racing	00 - 07	•	
SX	400	00 - 02	•	
EXC-F	450	04 - 18	•	
SX-F	450	03 - 24	•	
XC-F	450	06 - 19	•	

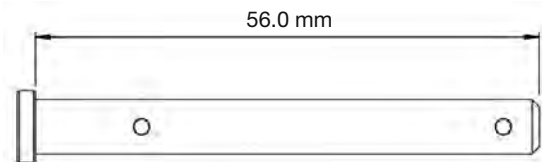

## SBS 4507

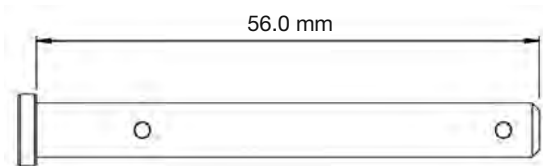

<b>KTM</b>				
EXC-F	500	12 - 18		•
XC-F	505	08 - 09		•
EXC	520 Racing	00 - 02		•
SX-F	520	00 - 02		•
EXC	525 Racing	03 - 06		•
SX-F	525	03 - 06		•
XC-F	525	07 - 07		•
EXC	530 Racing	08 - 11		•

## SBS 4508

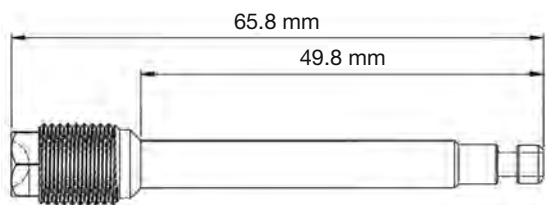

<b>HONDA</b>				
CR	125 R	02 - 07		•
CR	250 R	02 - 07		•
CRF	250 R	04 - 20		•
CRF	250 X	04 - 14		•
CRF	450 R	02 - 18		•
CRF	450 RX	17 - 18		•
CRF	450 X	05 - 18		•
<b>SUZUKI</b>				
RM	125	05 - 09		•
RM	250	05 - 09		•
RM-Z	250	08 - 18		•
RM-Z	450	08 - 18		•

## SBS 4509

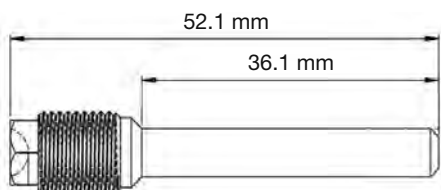

<b>KAWASAKI</b>				
KX	125	97 - 08		•
KX	250	97 - 08		•
KX	250 F	04 - 18		•
KX	450 F	06 - 18		•
<b>SUZUKI</b>				
RM-Z	250	04 - 06		•

**SBS 4510**



<b>HUSQVARNA</b>				
CR	125	05 - 13		•
TC	125	14 - 18		•
TE	125	14 - 16		•
TX	125	17 - 18		•
CR	250	05 - 05		•
FC	250	14 - 18		•
FE	250	14 - 18		•
TC	250	04 - 18		•
TE	250	02 - 18		•
TE	300	14 - 18		•
FC	350	14 - 18		•
FE	350	14 - 18		•
TC	449	11 - 13		•
FC	450	14 - 18		•
FE	450	14 - 18		•
TE	450	14 - 14		•
FE	501	14 - 18		•
TE	511	11 - 13		•
<b>KTM</b>				
EXC	125 Enduro	04 - 15		•
SX	125	00 - 18		•
SX	144	07 - 08		•
SX	150	09 - 18		•
EXC	200 Enduro	04 - 16		•
SX	200	03 - 04		•
EXC	250 Enduro	04 - 08		•
EXC	250 Enduro 4T	04 - 06		•
EXC	250 TPI	18 - 18		•
EXC-F	250	07 - 18		•
SX	250	03 - 18		•
SX-F	250	06 - 18		•
XC	250	06 - 14		•
EXC	300 Enduro	04 - 08		•
EXC	300 TPI	18 - 18		•
XC	300	06 - 14		•
EXC-F	350	11 - 18		•
SX-F	350	11 - 18		•
XC-F	350	12 - 19		•
EXC	400 Racing	00 - 07		•
SX	400	00 - 02		•
EXC-F	450	04 - 18		•
SX-F	450	03 - 24		•
XC-F	450	06 - 19		•
EXC-F	500	12 - 18		•
XC-F	505	08 - 09		•
EXC	520 Racing	00 - 02		•
SX-F	520	00 - 02		•
EXC	525 Racing	03 - 06		•
SX-F	525	03 - 06		•
XC-F	525	07 - 07		•
EXC	530 Racing	08 - 11		•

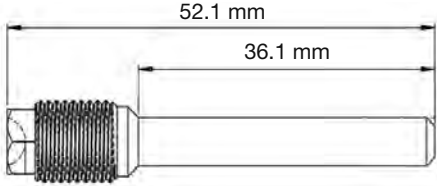

## Notes



## Notes





## Notes





# WORLD SUPERSPORT 300

## CHAMPION

CONGRATULATIONS

### Jeffrey Buis

MtM Kawasaki Racing

2020 & 2023

# 2023



SBS 955 DS-1 Dual Sinter

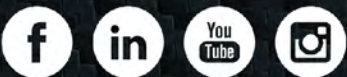

@sbsbrakes | sbsbrakes.com | #GoAhead





# HI-TECH BRAKE SOLUTIONS MADE IN EUROPE

At SBS, we develop and manufacture hi-tech brake solutions.

Our ranges of brake pads, brake discs, brake shoes, clutch kits and other important parts cover all relevant motorcycles, scooters and ATV/UTVs on the market, regardless of make and model. SBS is your single source for brake parts and components.

We are a global market leader within brakes for powered two-wheelers. Our R&D department continuously innovates with new materials and technologies to achieve ultimate performance, longer lifetime, higher comfort and more eco-friendly products.

Our products are tested by reality. Dynamometer testing is supplemented with numerous street and race track tests. We work together with some of the world's best road racing and motocross riders, when they race towards podium positions.

We create the power to stop you. Made in Europe. You decide where and how to use it. Go Ahead!



@sbsbrakes | sbsbrakes.com | #GoAhead

